

GUARANTEE & LIABILITY

Your Perrin & Rowe product has been manufactured to exacting standards. However, in the unlikely event that you should experience any defect, the following guarantees will apply:

Your Perrin & Rowe product is guaranteed against any mechanical defect within five years of the date of purchase. Should a fault occur; a free replacement part will be issued. In the event that this does not resolve the defect, a replacement product will be supplied.

The surface finish of Perrin & Rowe products are guaranteed for one year from the date of purchase. This is provided our care and maintenance instructions have been followed and that no scouring or aggressive cleaning agents have been used.

This does not affect your statutory rights.

For full terms and conditions please contact Perrin & Rowe.

SPARES

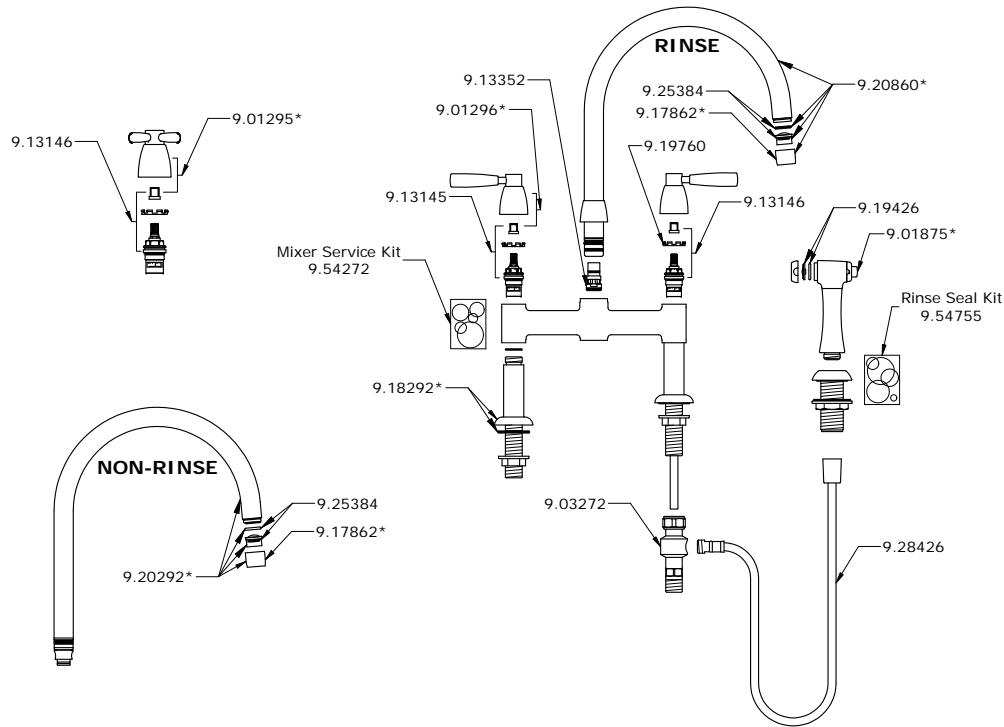

* Where indicated please specify colour

SPARE PARTS & SERVICE



Phone: +44 (0) 1708 526361
Fax: +44 (0) 1708 550220

enquiries@perrinandrowe.co.uk
www.perrinandrowe.co.uk

Perrin & Rowe products are manufactured in the UK, using the latest technology and built to the highest quality standards.

We would like to thank you for purchasing a Perrin & Rowe product and take this opportunity to invite you to look at other luxury products by us. Please contact us to receive our latest catalogue.



The Contemporary Kitchen Collection

Installation & User Guide

10 2 HOLE MIXERS

• E.4292 • E.4293

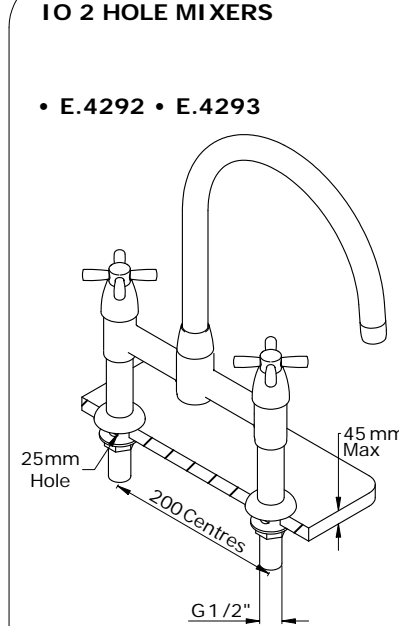

• E.4272 • E.4273

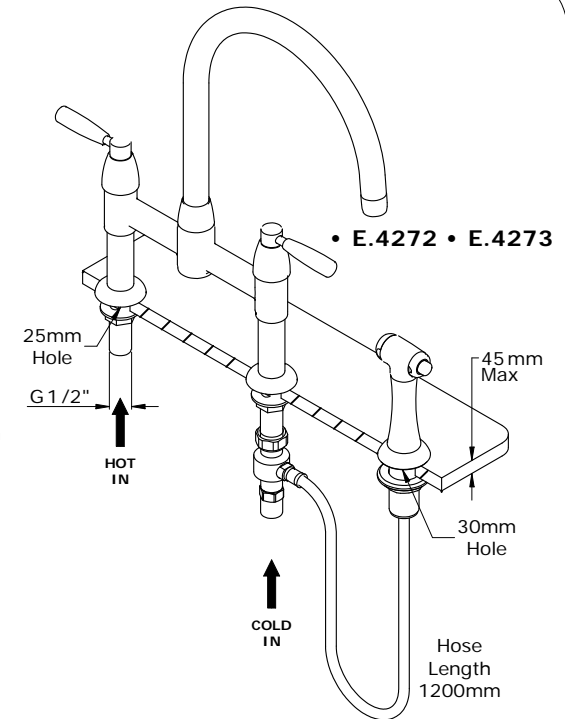

Temp Range:
Min 1°C/34°F
Max 85°C/185°F

Recommended Working Pressure:
Min 1bar/15psi
Max 5bar/75psi

Ideal performance obtained with equal hot & cold pressures.

Congratulations on the purchase of your Perrin & Rowe Kitchen Product. Correctly installed and with sensible care, this product will give you many years of trouble free service.

IMPORTANT INFORMATION

Before you proceed... We recommend you engage the services of a registered plumber to install this product.

For ease of possible future servicing, we also recommend the fitting of conveniently placed isolating valves.

In addition to the guide below it is essential that the written information overleaf is carefully read and understood.

Preparation Check Box for Installer

- Flush the plumbing system before installing the kitchen product.
- Once unpacked remove Fibre Washer, Plastic Backnut and Rinse Connector ready for installation.

1

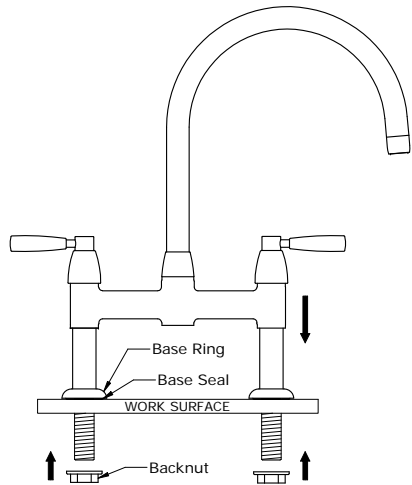

Ensure the mixer is orientated correctly, levers should rotate to point forward.

Secure mixer with a suitable tap wrench or a 26 AF Spanner.

The kitchen tap with rinse is supplied with a brass tube protruding out of the bottom of the shank. Please be careful not to damage the end of this tube during installation.

If your mixer has a rinse please follow steps 2,3 & 4 to install correctly, otherwise please connect Hot & Cold water supplies.

Ensure all connections are firmly tightened

2

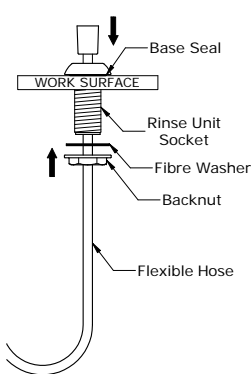

Secure rinse unit socket in a suitable position using a tap wrench or a 36 AF spanner.

Place flexible hose through top of rinse unit socket as shown in diagram.

3

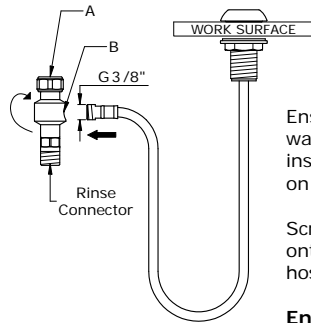

Ensure black rubber washers are situated inside position A and B on the rinse connector.

Screw rinse connector onto end of flexible hose.

Ensure connection is firmly tightened.

4

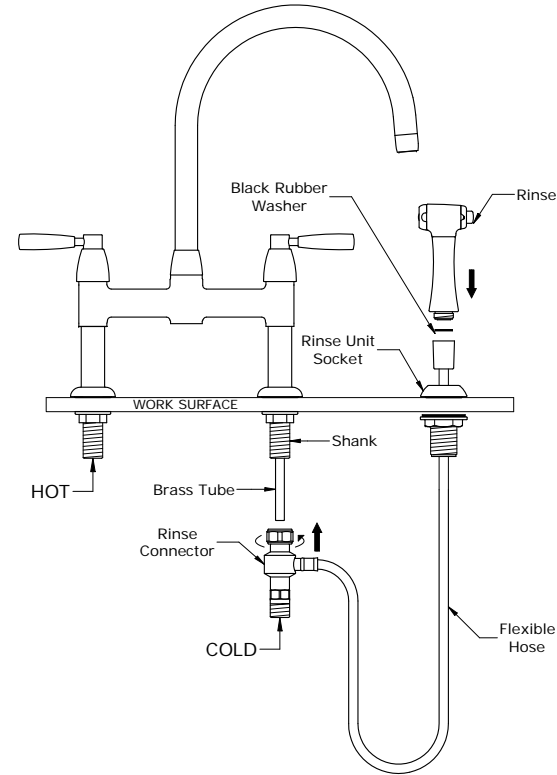

Important - Do not cut brass tube.

Carefully feed the rinse connector over the protruding brass tube and secure tightly onto the shank.

Ensure black rubber washer is in place before securing rinse to flexible hose.

Holding the rinse, screw the flexible hose onto the end of rinse and place into rinse unit socket. Make sure orientation of rinse is correct.

Connect Hot & Cold water supplies.

Ensure all connections are firmly tightened.

Please Note: Ceramic disc valves are fitted as standard to this mixer. Flow from FULLY OFF to FULLY ON is achieved by rotating the handles a quarter turn.

BEFORE USE

- Carefully check the installation for leaks.
- If further building work is to be carried out in the vicinity, cover the tap to avoid damaging the finish.
- Please ensure that the installation complies with the water supply bye-laws.

CARE & MAINTENANCE

Wipe down after use to avoid water spotting and mineral build up.

Occasional cleaning with warm soapy water, followed by a polish with a soft cloth is all that is required to keep the plated finish in good condition.

Do not use proprietary abrasive liquids, powders, or pads to clean the shower. Do not use any products with ammonia bleach or limescale remover. You will damage the plated finish and void your guarantee.