



Qubino

Qubino 3 phases Smart Meter

SKU: GOAEZMNHXD1



Quickstart

This is a **secure Smart Meter** for **Europe**. To run this device please connect it to your mains power supply. To add this device to your network execute the following action:

Toggle the Service button S between 0.2 and 6 seconds

Important safety information

Please read this manual carefully. Failure to follow the recommendations in this manual may be dangerous or may violate the law. The manufacturer, importer, distributor and seller shall not be liable for any loss or damage resulting from failure to comply with the instructions in this manual or any other material. Use equipment only for its intended purpose. Follow the disposal instructions. Do not dispose of electronic equipment or batteries in a fire or near open heat source.

What is Z-Wave?

Z-Wave is the international wireless protocol for communication in the Smart Home. This device is suited for use in the region mentioned in the Quickstart section.

Z-Wave ensures a reliable communication by reconfirming every message (**two-way communication**) and every mains powered node can act as a repeater for other nodes (**meshed network**) in case the receiver is not in direct wireless range of the transmitter.

This device and every other certified Z-Wave device can be **used together with any other certified Z-Wave device regardless of brand and origin** as long as both are suited for the same frequency range.

If a device supports **secure communication** it will communicate with other devices secure as long as this device provides the same or a higher level of security. Otherwise it will automatically turn into a lower level of security to maintain backward compatibility.

For more information about Z-Wave technology, devices, white papers etc. please refer to www.z-wave.info.



Product Description

The Qubino Smart Meter is an extremely versatile and powerful Z-Wave module for measuring energy in a single-phase electrical power network of up to 6 poles. The microprocessor calculates energy, power and power factor from the measured signals. It is designed to be mounted on a DIN rail.

The Qubino Smart Meter can be used in residential, industrial and utility applications. It measures energy directly in 2-wire networks by means of fast sample and hold voltage and current signals. It calculates energy, power and power factor from the measured signals. You can control the module through the Z-Wave network. The Smart Meter can also act as a repeater in order to improve the range and stability of the Z-Wave network. The Smart Meter is designed to be mounted on a DIN rail.

Properties:

- Z-Wave Plus
- EU frequency: 868.42 MHz
- Package content: 1x Qubino Smart Meter

Main terminals (L1, N1, Lo, No)

- Contacts capacity: 1.5...16(25)mm²
- Connection screws: M5

- Max torque: 3.5 Nm

Optional terminals (1,2,4,5)

- Contact capacity: 0.05 ... 1 (2.5) mm²
- Connection screws: M3
- Max torque: 0.6 Nm

Measuring input

- Type (connection): single phase (1b)
- Reference current (Iref): 5 A
- Maximum current (Imax): 65 A
- Minimum current (Imin): 0.25 A
- Starting current: 20 mA
- Voltage (Un): 230 V (±20%)
- Power consumption at Un: < 2 W
- Nominal frequency (fn): 50 and 60 Hz

Accessory

- IKA232-20/230 V (GOAEIKA23220)
- BICOM432-40-WM1 (GOAEBICOM432)

Prepare for Installation / Reset

Please read the user manual before installing the product.

In order to include (add) a Z-Wave device to a network it **must be in factory default state**. Please make sure to reset the device into factory default. You can do this by performing an Exclusion operation as described below in the manual. Every Z-Wave controller is able to perform this operation however it is recommended to reset the primary controller of the previous network to make sure the very device is excluded properly from this network.

Reset to factory default

This device also allows to be reset without any involvement of a Z-Wave controller. This procedure should only be used when the primary controller is inoperative.

Press and hold the S service button between 6 seconds and 20 seconds

Safety Warning for Mains Powered Devices

ATTENTION: only authorized technicians under consideration of the country-specific installation guidelines/norms may do works with mains power. Prior to assembly of the product, the voltage network has to be switched off and ensured against re-switching.

Installation

Step 1 – Turn OFF the fuse:

- To prevent electrical shock and/or equipment damage, disconnect electrical power at the main fuse or circuit breaker before installation and maintenance.
- Be aware that even if the circuit breaker is off, some voltage may remain in the wires — before proceeding with the installation, be sure no voltage is present on the wiring.
- Take extra precautions to avoid accidentally turning the device on during installation.

Step 2 – Installing the device:

- Connect the device exactly according to the diagrams shown below

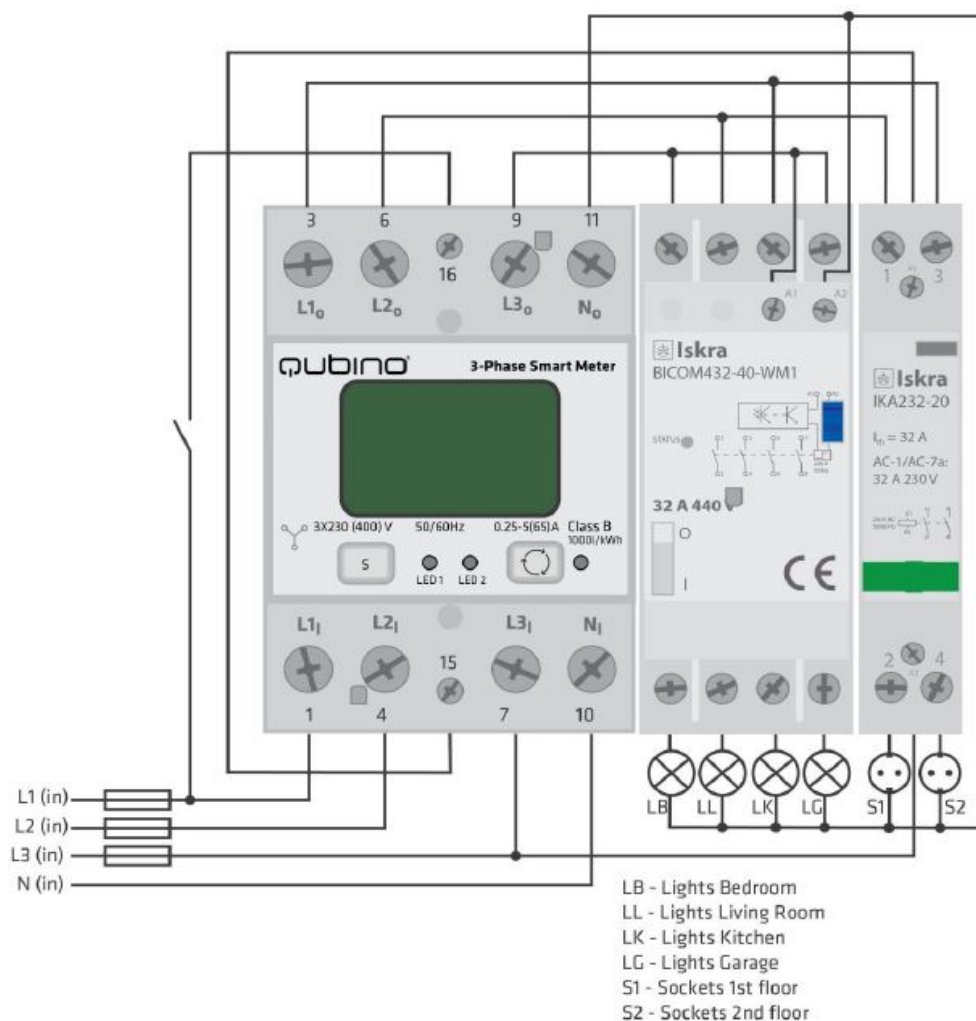

Step 3 – Turn ON the fuse:

Step 4 – Add the device to your Z-Wave network:

-For more details on how to include the device, please refer to the Z-Wave Inclusion chapter.

Step 5 – The Installation is now complete. It's time to make your life more comfortable with the help of the Qubino 3-Phase Smart Meter

EXTERNAL RELAYS:

It is possible to connect two external relays to 3-Phase Smart Meter device. One controlled by built-in optical (IR) communication port on the side, second c output on terminal 15.

* IKA and BICOM are sold separately - for more info, please see Qubino catalogue. Product ordering codes (model numbers): IKA232-20/230V: 030 046 83 BICOM432-40-WM1: 30.074.038

Inclusion/Exclusion

On factory default the device does not belong to any Z-Wave network. The device needs to be **added to an existing wireless network** to communicate with devices of this network. This process is called **Inclusion**.

Devices can also be removed from a network. This process is called **Exclusion**. Both processes are initiated by the primary controller of the Z-Wave network controller is turned into exclusion respective inclusion mode. Inclusion and Exclusion is then performed doing a special manual action right on the device.

Inclusion

Toggle the Service button S between 0.2 and 6 seconds

Exclusion

Toggle the Service button S between 0.2 and 6 seconds

Auto-Inclusion

Beside the standard inclusion this device supports the so called **auto inclusion**. Right after powering up the device remains in inclusion state and can be (any) gateway without further actions on the device itself. The auto inclusion mode will time out after some time.

Product Usage

The 3-Phase Smart Meter can be used in many different scenes, which can help make your life more comfortable. We have prepared a few of them for you get an idea for your next smart home project. Of course, there are countless of other options for how to use Qubino 3-Phase Smart Meter to remotely control your smartphone.

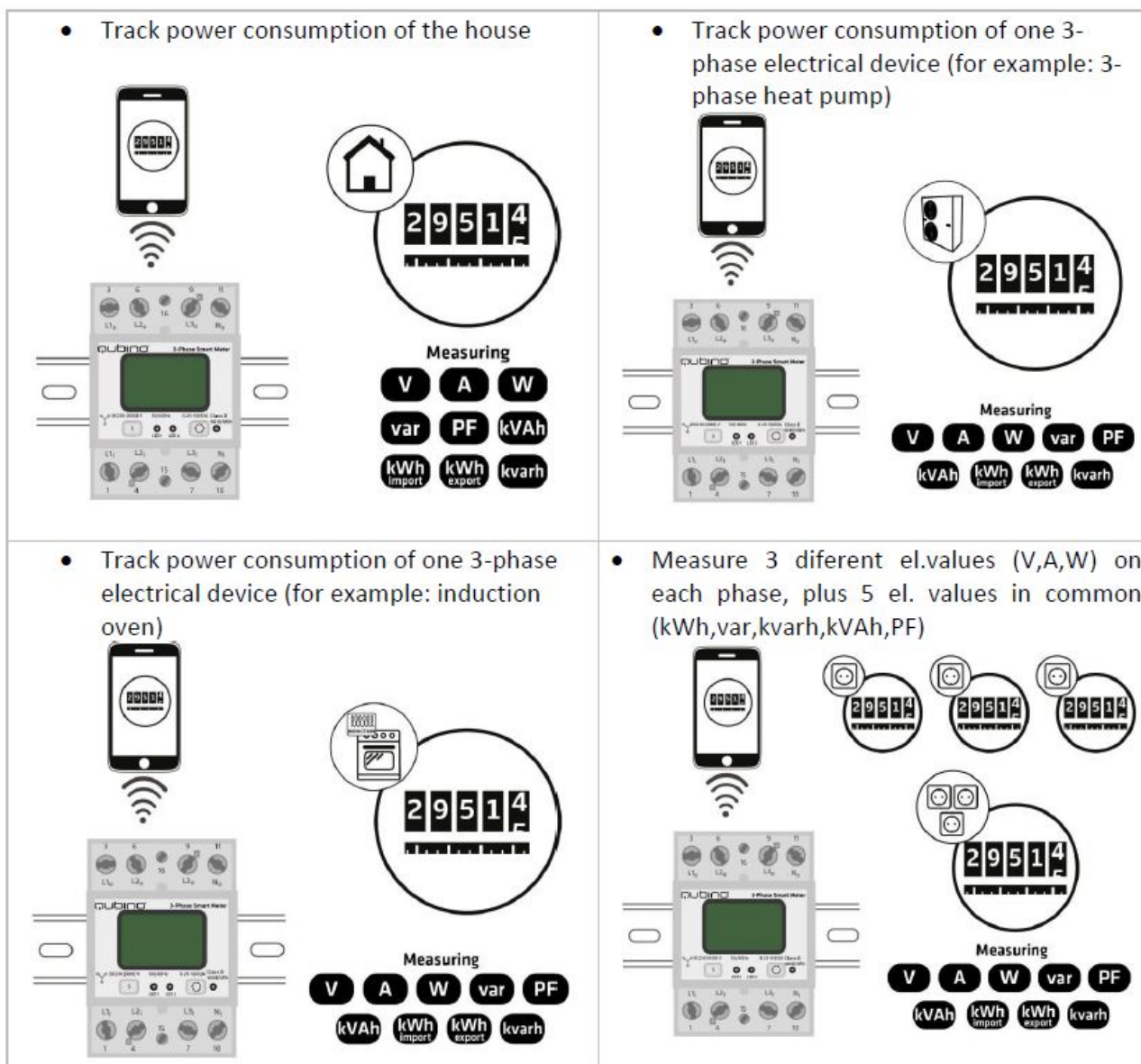

LED SIGNALIZATION FOR INCLUSION/EXCLUSION

LED1 (Green)

- LED is ON = Power ON, module is included
- LED is 1s OFF, 1s ON = Power ON, module is excluded

LED2 (Yellow)

- External IR relay enabled only
 - LED is ON = External IR relay is turned ON
 - LED is OFF = External IR relay is turned OFF
 - LED is 0.5s OFF, 0.5s ON = IR communication error
- External TRIAC relay enabled only
 - LED is ON = External IR relay is turned ON
 - LED is OFF = External IR relay is turned OFF
- Both TRIAC and IR enabled
 - LED is ON = External IR relay is turned ON
 - LED is OFF = External IR relay is turned OFF

- LED is 0.5s OFF, 0.5s ON = IR communication error
- d. External IR relay disabled
- LED is ON = modbus packet is sent
- LED is OFF = modbus packet is received

Quick trouble shooting

Here are a few hints for network installation if things dont work as expected.

1. Make sure a device is in factory reset state before including. In doubt exclude before include.
2. If inclusion still fails, check if both devices use the same frequency.
3. Remove all dead devices from associations. Otherwise you will see severe delays.
4. Never use sleeping battery devices without a central controller.
5. Dont poll FLIRS devices.
6. Make sure to have enough mains powered device to benefit from the meshing

Association - one device controls an other device

Z-Wave devices control other Z-Wave devices. The relationship between one device controlling another device is called association. In order to control a device, the controlling device needs to maintain a list of devices that will receive controlling commands. These lists are called association groups and they are related to certain events (e.g. button pressed, sensor triggers, ...). In case the event happens all devices stored in the respective association group will receive the same wireless command, typically a 'Basic Set' Command.

Association Groups:

Group Number	Maximum Nodes	Description
1	1	Lifeline

Configuration Parameters

Z-Wave products are supposed to work out of the box after inclusion, however certain configuration can adapt the function better to user needs or unlock further enhanced features.

IMPORTANT: Controllers may only allow configuring signed values. In order to set values in the range 128 ... 255 the value sent in the application shall be value minus 256. For example: To set a parameter to 200 it may be needed to set a value of 200 minus 256 = minus 56. In case of a two byte value the same applies: Values greater than 32768 may be needed to be given as negative values too.

Parameter 7: Input switch function selection

Available configuration parameters for input switch 1

Size: 1 Byte, Default Value: 0

Setting	Description
0	disabled
2	IR external relay control – mono stable push button
3	IR external relay control – bi-stable switch
4	External relay control – mono stable push button
5	External relay control – bi-stable switch

Parameter 40: Reporting on power change

This parameter is valid for Active Power Total, Active Power Phase1, Active Power Phase2 and Active Power Phase3.

NOTE: if power change is less than 5 W, the report is not send (pushed). **NOTE:** Device is measuring also some disturbances even if on the output is no load disturbances:- If measured Active Power (W) is below e.g. 5W-> the reported value in this case is 0W

Size: 1 Byte, Default Value: 50

Setting	Description
0	reporting disabled
1 - 100	1% - 100% reporting enabled. Power report is send only when actual power in Watts (in real time change more than set percentage comparing to previous Active Power, step is 1%.

Parameter 42: Reporting on time interval

This parameter is currently valid only for Active Energy Total Import/Export (kWh), Reactive Energy Total (kvarh), Total Energy (kVAh)

Note: Device is reporting only if there was a change of 0.1 in Energy **Note:** In the future will be possible to measure and report also Active Energy on PH1, PH2, PH3.

Size: 2 Byte, Default Value: 600

Setting	Description
0	reporting disabled
600 - 65536	Reporting enabled. Report is send with the time interval set by entered value. Seconds

Parameter 43: Other Values - Reporting on time interval

This parameter is valid only for Voltage (V of ph1, ph2, ph3), Current (A of ph1, ph2, ph3), Total Power Factor, Total Reactive Power (var)

Note: Device is reporting only if there was a change

Size: 2 Byte, Default Value: 600

Setting	Description
0	reporting disabled
600 - 65536	Reporting enabled. Report is send with the time interval set by entered value. Seconds

Parameter 100: Enable / Disable External IR relay (BICOM)

NOTE1: After parameter change, first exclude module (without setting parameters to default value) and then re include the module. NOTE 2: If you don't have BICOM relay module mounted and you enable IR communication (parameter 100 is 1 or 2) there will be no valid IR relay state reported. It will be reported as COMMUNICATION ERROR and LED2 will BLINK.

Size: 1 Byte, Default Value: 0

Setting	Description
0	External IR relay disabled
1	External IR relay enabled and connected to all 3 Phases
2	External IR relay enabled and connected to a Phase 1

Parameter 101: Enable / Disable External relay (IKA)

After parameter change, first exclude module (without setting parameters to default value) and then re include the module.

Size: 1 Byte, Default Value: 0

Setting	Description
0	External relay disabled
1	External relay enabled and connected to Phase 2

Parameter 106: External IR relay (BICOM) power threshold settings – maximum power of all phases together

This parameter defines a threshold when External IR relay is being turned off. (If Parameter no. 100 is set to the value 1 or 2)

NOTE: Meter is capable of measuring max 3x65A!

Size: 2 Byte, Default Value: 0

Setting	Description
0	no function
10 - 60000	Watt

Parameter 107: External relay (IKA) power threshold settings – maximum power on phase L2

This parameter defines a threshold when External relay is being turned off (if the parameter no. 100 is set to the value 1 or 2).

NOTE: Meter is capable of measuring max 65A

Size: 2 Byte, Default Value: 0

Setting	Description
0	no function
10 - 20000	Watt

Parameter 112: Power threshold – Delay before power on

External IR relay/ External relay is turned off due to detected overload (as set by parameter 106&107) and remains off for a time, defined in this parameter. time, the output turns on to check, if the overload is still present.

NOTE: the delay time may be prolonged for more then 10s of the time set by the parameter.

Size: 2 Byte, Default Value: 0

Setting	Description
0	External IR relay/ External relay will not turn back on
30 - 32535	Seconds

Technical Data

Dimensions	53,6 x 84 x 65 mm
Weight	221 gr
Hardware Platform	ZM5101
EAN	3830062070683
IP Class	IP 20
Voltage	3x 230 V/400V
Load	65 A
Device Type	Smart Meter
Firmware Version	01.00
Z-Wave Version	04.3d
Z-Wave Product Id	0x0159.0x0007.0x0054
Frequency	Europe - 868,4 Mhz
Maximum transmission power	5 mW

Supported Command Classes

- Basic
- Switch Binary
- Meter
- Crc 16 Encap
- Association Grp Info
- Device Reset Locally
- Zwaveplus Info
- Multi Channel
- Supervision
- Configuration
- Manufacturer Specific
- Powerlevel
- Firmware Update Md
- Association
- Version
- Multi Channel Association
- Security
- Transport Service
- Security 2

Controlled Command Classes

- Transport Service
- Security 2

Explanation of Z-Wave specific terms

- **Controller** — is a Z-Wave device with capabilities to manage the network. Controllers are typically Gateways, Remote Controls or battery operated wall controllers.
- **Slave** — is a Z-Wave device without capabilities to manage the network. Slaves can be sensors, actuators and even remote controls.
- **Primary Controller** — is the central organizer of the network. It must be a controller. There can be only one primary controller in a Z-Wave network.
- **Inclusion** — is the process of adding new Z-Wave devices into a network.
- **Exclusion** — is the process of removing Z-Wave devices from the network.
- **Association** — is a control relationship between a controlling device and a controlled device.
- **WakeUp Notification** — is a special wireless message issued by a Z-Wave device to announce that it is able to communicate.
- **Node Information Frame** — is a special wireless message issued by a Z-Wave device to announce its capabilities and functions.

(c) 2020 Z-Wave Europe GmbH, Antonstr. 3, 09337 Hohenstein-Ernstthal, Germany, All rights reserved, www.zwave.eu. The template is maintained by [Z-Wave Europe GmbH](#). The product content is maintained by Z-Wave Europe GmbH, Supportteam, support@zwave.eu. Last update of the product data: 2018-07-23 15:04:07