

# CO2 Monitor

MH9-CO2-WA/WD

## Introduction

MCOHome CO2 Monitor is an air quality detector which compatible with Z-Wave Plus technology, it is mainly used to monitor CO2 concentration in industrial, agricultural, and residence environment, while monitoring the indoor temperature, humidity and VOC air quality. Device can be included into any Z-Wave network, and is compatible with any other Z-Wave certified devices.

## Specification

- Power Supply : DC12V (WD); AC220V±10 % 50/60HZ (WA)
- CO2 display range: 0-2000ppm
- Default threshold: 1000ppm (adjustable)
- Temperature range: -9~50°C (15-122°F)
- Humidity range: 0%~99%RH
- Installation: Wall-mounted (Vertical)
- Work environment: -10~+8°C 0-90%RH (Non-condensation)
- Dimension: 90\* 130\*28mm
- Hole Pitch: 60mm or 82mm
- Housing: Tempered glass+ PC Alloy

## Safety Information

To protect yourself and others from danger and to protect the device from damage, please read the safety information before using it.

### ***Important!***

- A qualified electrician with the understanding of wiring diagrams and knowledge of electrical safety should complete installation following the instructions.
- Before installation, please confirm the real voltage complying with the device's specification. Cut off any power supply to secure the safety of people and device.
- During installation, protect the device from any physical damage by dropping or bumping. If happens, please contact the supplier for maintenance.
- Keep the device away from acid-base and other corrosive solids, liquids, gases, to avoid damage.
- Avoid overexertion during operation, to protect device from mechanical damage.
- Read all instructions and documentation and save for future reference.

## Installation & Wiring

### **Location:**

Device is suggested to be installed indoor, a place with around 1.5m height above the floor where represents the average CO2 concentration. It should be away from direct sunlight, any cover, or any heat source, to avoid false signal for temperature control.

**Notice!**

1. Device must be wall-mounted vertically. Do not lay it flat or upside down while working.
2. Do not mounted it in a wind gap, or cover its bottom, which may affect the detected data.

MH9-CO2-WA

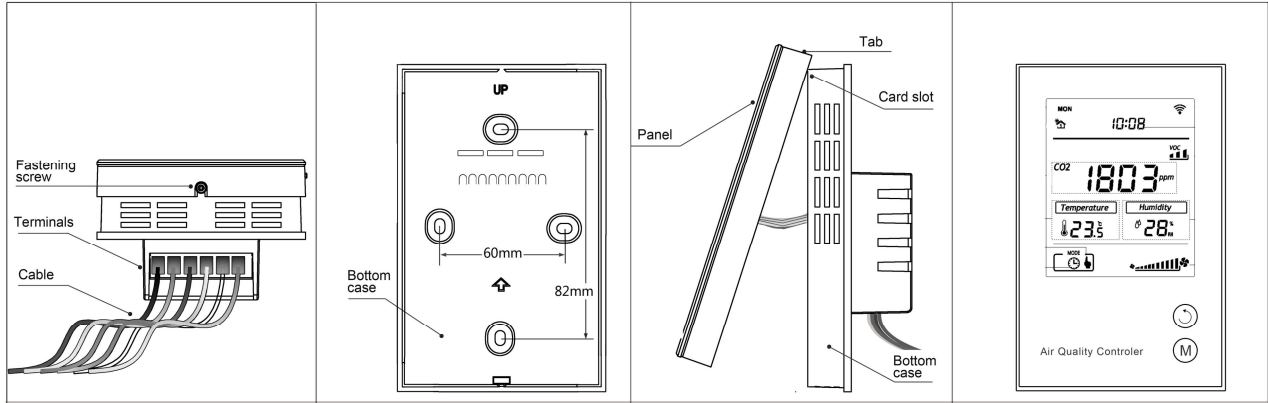

MH9-CO2-WD

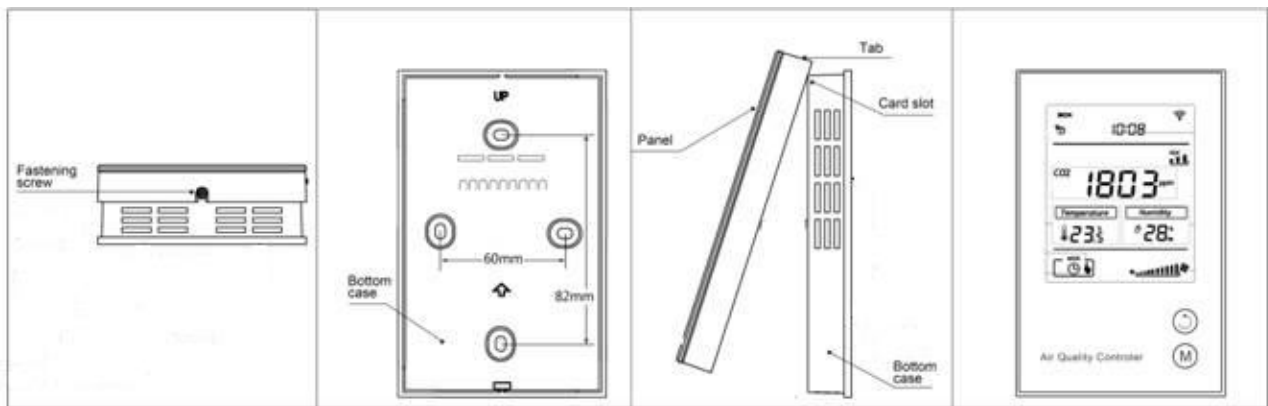

- Step 1:** Separate Panel and Bottom case by removing the screw at the bottom of device. Insert all wires into the right terminals and tighten screws. The wiring diagram is shown as below.
- Step 2:** Mount the Bottom case onto wall with two screws (M4\*25mm). The hole pitch 60mm is for 86/60mm box, and 82mm is for American 120mm box.
- Step 3:** Mount the Panel back by aligning its tabs and card slot onto the Bottom case.
- Step 4:** Tighten the fastening screw and the device is ready for normal work.

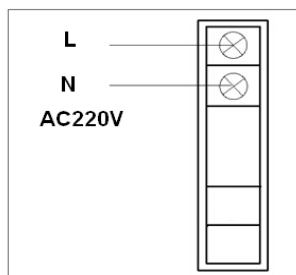

MH9-CO2-WA

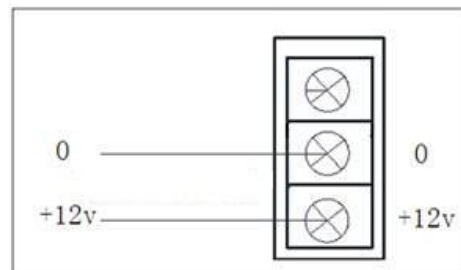

MH9-CO2-WD

**Pay attention to the current direction of positive and negative, otherwise device will easily be burn!**

## Button & Display

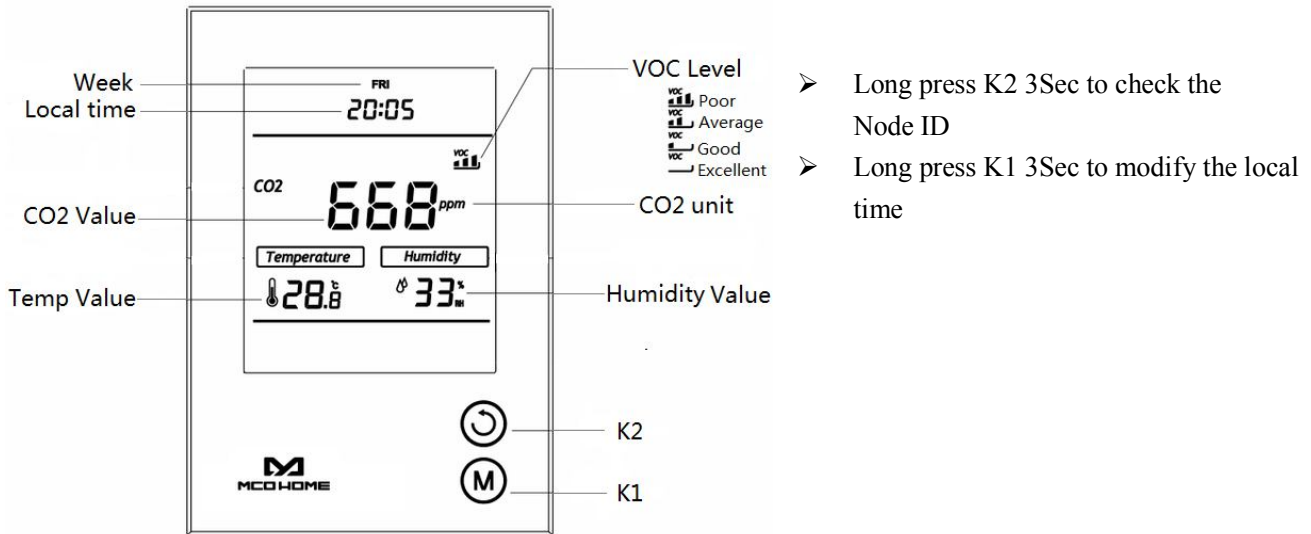

## Operation

### Local time setting

In normal display interface, long press K1 will enter the local time modification interface.

- “Week” starts flashing, press K2 can switch among “MON-TUE-WED-THU-FRI-SAT-SUN”. Choose one then press K1 will save the setting.
- “Hour” starts flashing. Press K2, the value will cycle switchover from 00-23. Press K1 to save the change.
- “Minute” starts flashing. Press K2, the value will cycle switchover from 00-59. Then press K1 can save settings and return to normal display.

In the process of modification, long press K1 can save and return to the normal interface, long press K2 can continuously increase the value.

### VOC detection

Device has built-in a VOC sensor which can only be check locally (not able to check via Z-Wave), and four levels can be detected and shown on the display: **Excellent, Good, Average & Poor**. (VOC toxic gases include carbon monoxide, alcohol, hydrogen, methane, isobutene, ammonia and benzene, etc.)

### Fahrenheit/Celsius switch

Long press K1+K2 button, enter into Secret Menu interface, press K2 button to input the value, press K1 to switch the value, and enter password 5166. Then press K1 to enter into Secret Menu. Temperature display area will flash “°C” .

1. Press K2button can switch between“°C”and“°F”
2. After setting, press K1 button to confirm and quit.

**Calibration**

Long press K1+ K2 button, enter into Secret Menu interface, press K2 button to input the value, press K1 to switch the value, and enter password 1234. Then press K1 button enter into Secret Menu. “01” parameter number will be displayed, the current value flashes.

1. Press K2 to modify the parameters.
2. Press K1 as enter confirmation and switch to the next item to modify the value.
3. After setting, press K1 to confirm then quit.

**Following is the information of each parameter:**

Item	Parameter	Range	Default Value
01	Temperature Calibration	-5°C~+5°C	00°C
02	Humidity Calibration	-9%RH~+9%RH	00
03	CO2 Calibration	-99~+99	00
04	Backlight Brightness Settings	00-09 (00: backlight normally open)	00

**Z-Wave Operation**

● **Including& Excluding of Z-Wave network**

Activate Inclusion/Exclusion mode in the gateway. When device is powered on, long press K2 can enter interface for inclusion or exclusion of Z-Wave network.

- If device has not been included into any Z-Wave network before, “- - -”will display on the screen.
- Then press K2 once, “---” flashing and device enters into learning mode to get a node ID. If inclusion is success, a node ID will display on the screen. If not, “---” will stop flashing in 20s.
- If a node ID displays, it means the device is already in a Z-Wave network. To press K2 once can remove it from the network. “- - -” displays and press K1 once can return to normal work.

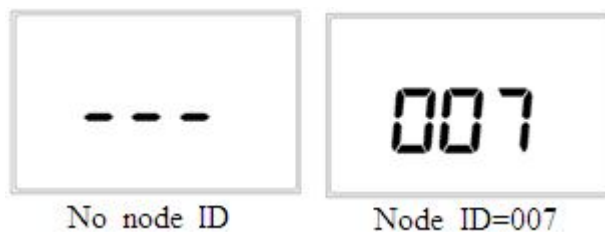

● **Association Group**

Device supports 1 association group:

- For “Notification” purpose, device works in “Push” mode in “Notification Command Class”. Use “Configuration” can set the threshold of CO2 Notification report.  
When detected value is more than setting value, device will send (CO2 Detected Event) report to the Group 1. And this report will keep sending in every 30 sec unless the detected value lower than setting value.  
Use “Notification Set” can set this unsolicited report; this function is default as “OFF”.

- A gateway is suggested to associate with Group 1, which can support only one Node ID. The gateway can ask for detected data any time. And the device will report to this associated device (gateway) when detected data changes.

- Parameters setting:

Add	Function	Byte	Options	Default	Remark
0x01	CO2 Notification threshold	2	1-5000	1000	
0x02	CO2 report interval	1	=0 report disabled ≥10 report when change ≥n*5ppm	10	50ppm
0x03	Temperature report interval	1	=0 report disabled ≥1 report when change ≥n*0.5°C	1	0.5°C
0x04	Humidity report interval	1	=0 report disabled ≥2 report when change ≥n%	2	2%
FF	Factory setting	1	0x55 Restore the factory setting(write only)		Parameters setting back to default value, association groups deleted

- **Command Class supported by the device:**

COMMAND\_CLASS\_BASIC  
COMMAND\_CLASS\_SENSOR\_MULTILEVEL\_V5  
COMMAND\_CLASS\_CONFIGURATION  
COMMAND\_CLASS\_NOTIFICATION  
COMMAND\_CLASS\_ASSOCIATION  
COMMAND\_CLASS\_MANUFACTURER\_SPECIFIC  
COMMAND\_CLASS\_VERSION

### 1-year Limited Warranty

MCOHome warrants this product to be free from defects in material and workmanship under normal and proper use for one year from purchase date of the original purchaser. MCOHome will, at its option, either repair or replace any part of its products that prove defective by reason of improper workmanship or materials. THIS LIMITED WARRANTY DOES NOT COVER ANY DAMAGE TO THIS PRODUCT THAT RESULTS FROM IMPROPER INSTALLATION, ACCIDENT, ABUSE, MISUSE, NATURAL DISASTER, INSUFFICIENT OR EXCESSIVE ELECTRICAL SUPPLY, ABNORMAL MECHANICAL OR ENVIRONMENTAL CONDITIONS, OR ANY UNAUTHORIZED DISASSEMBLY, REPAIR OR MODIFICATION. This limited warranty shall not apply if: (i) the product was not used in accordance with any accompanying instructions, or (ii) the product was not used for its intended function. This limited warranty also does not apply to any product on which the original identification information has been altered, obliterated or removed, that has not been handled or packaged correctly, that has been sold as second-hand or that has been resold contrary to Country and other applicable export regulations.