



Popp

POPP Solar Outdoor Siren 2

SKU: POPE700854



Quickstart

This is a **secure Siren** for **Europe**. To run this device please insert fresh **1 * Lithium 2400mAh** batteries. Please make sure the internal battery is fully charged.

The device usually comes pre-charged. In case there is not enough power, please place the device into sun light for 10 minutes.

1. Open the case and turn on the power switch by moving it towards the Z-Wave button?. All LEDs will shine for a short moment to confirm.
2. **Remove the metal mounting plate from the device.**
3. Remove all protection foil from the device.
4. Turn your controller into inclusion mode and start the inclusion with a short single click on the siren?s internal Z-Wave button?.

Once the siren is placed on the metal mounting plate, the tamper protection is activated. **Do not remove the siren anymore unless it is deactivated!**

Important safety information

Please read this manual carefully. Failure to follow the recommendations in this manual may be dangerous or may violate the law. The manufacturer, importer, distributor and seller shall not be liable for any loss or damage resulting from failure to comply with the instructions in this manual or any other material. Use this equipment only for its intended purpose. Follow the disposal instructions. Do not dispose of electronic equipment or batteries in a fire or near open heat sources.

What is Z-Wave?

Z-Wave is the international wireless protocol for communication in the Smart Home. This device is suited for use in the region mentioned in the Quickstart section.

Z-Wave ensures a reliable communication by reconfirming every message (**two-way communication**) and every mains powered node can act as a repeater for other nodes (**meshed network**) in case the receiver is not in direct wireless range of the transmitter.

This device and every other certified Z-Wave device can be **used together with any other certified Z-Wave device regardless of brand and origin** as long as both are suited for the same frequency range.

If a device supports **secure communication** it will communicate with other devices secure as long as this device provides the same or a higher level of security. Otherwise it will automatically turn into a lower level of security to maintain backward compatibility.

For more information about Z-Wave technology, devices, white papers etc. please refer to www.z-wave.info.



Product Description

This solar powered outdoor siren can be used without any additional power supply or batteries. It can be installed on any place on the outside of the house and can be controlled using Z-Wave. The device will issue a very loud sound (105 dBm) and in parallel some stroboscope light as well. The siren is self-protecting. Removing the main device from the mounting unit immediately starts the siren and also reports the tamper attempt to the ZWave central controller. All communication between the Z-Wave controller and the siren is encrypted and secured to protect against manipulation. Thanks to the large solar panel, the siren can be mounted on nearly every place outside the house where it's recommended to place it in indirect sun light to prevent strong heating-up the housing. The siren is maintenance-free and water-proofed (IP56). The average solar energy of one day keeps the device alive for up to 50 days (without using the siren).

The working range of the siren is: -10°C to +50°C

Prepare for Installation / Reset

Please read the user manual before installing the product.

In order to include (add) a Z-Wave device to a network it **must be in factory default state**. Please make sure to reset the device into factory default. You can do this by performing an Exclusion operation as described below in the manual. Every Z-Wave controller is able to perform this operation however it is recommended to use the primary controller of the previous network to make sure the very device is excluded properly from this network.

Reset to factory default

This device also allows to be reset without any involvement of a Z-Wave controller. This procedure should only be used when the primary controller is inoperable.

To reset the device keep the inclusion button pushed for 10 seconds. After 5 seconds the LED starts flashing and after another 5 seconds there is a short beep signaling the successful reset back to factory defaults. Use this procedure only when the network primary controller is missing or otherwise inoperable.

Safety Warning for Batteries

The product contains batteries. Please remove the batteries when the device is not used. Do not mix batteries of different charging level or different brands.

Installation

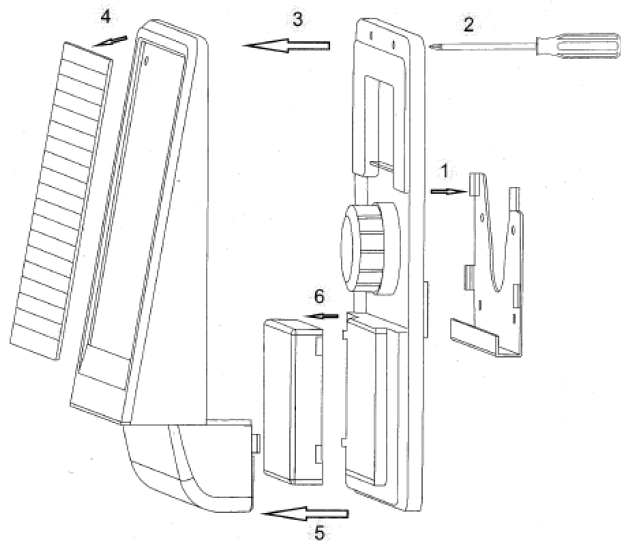

The siren can be placed on every location outside the home. Thanks to rating IP56 the location does not even need to be dry but please make sure it is placed high enough so that children do not accidentally remove it. The device is self-protected against tamper and theft. In a first step the mounting plate (see illustration above) is placed on the wall using the 4 screws provided. It is recommended to mount the complete device 5 mm from the wall for better sound.

1. Open the case and turn on the power switch (see illustration below) by moving it towards the Z-Wave button (B). All LEDs will shine for a short moment to confirm.
2. Remove the metal mounting plate from the device.
3. Remove all protection foil from the device.
4. Turn your controller into inclusion mode with a short single click on the internal Z-Wave button (see illustration below).

Once included the enclosure of the siren is closed using the 6 screws. Finally, the siren is placed on the mounting plate. Attention: As soon as the siren is placed on the mounting plate the tamper protection is activated. The siren must not be removed from the plate anymore. The behavior in this moment is defined by the configuration parameter No 1. (A) Power Button (B) Z-Wave Button (C) Battery Con (D) Solar Module Connection (E) Charge Connection (12V DC) (F) Speaker Connection ill. 1 ill. 2 3 The Siren comes pre-charged and can be used right away outside your home. If ? for whatever reason ? the device gets fully discharged, you need to charge it again for about 30 minutes before its operational again. During this time of initial charging the siren may issue some minor noise. This is not a malfunction.

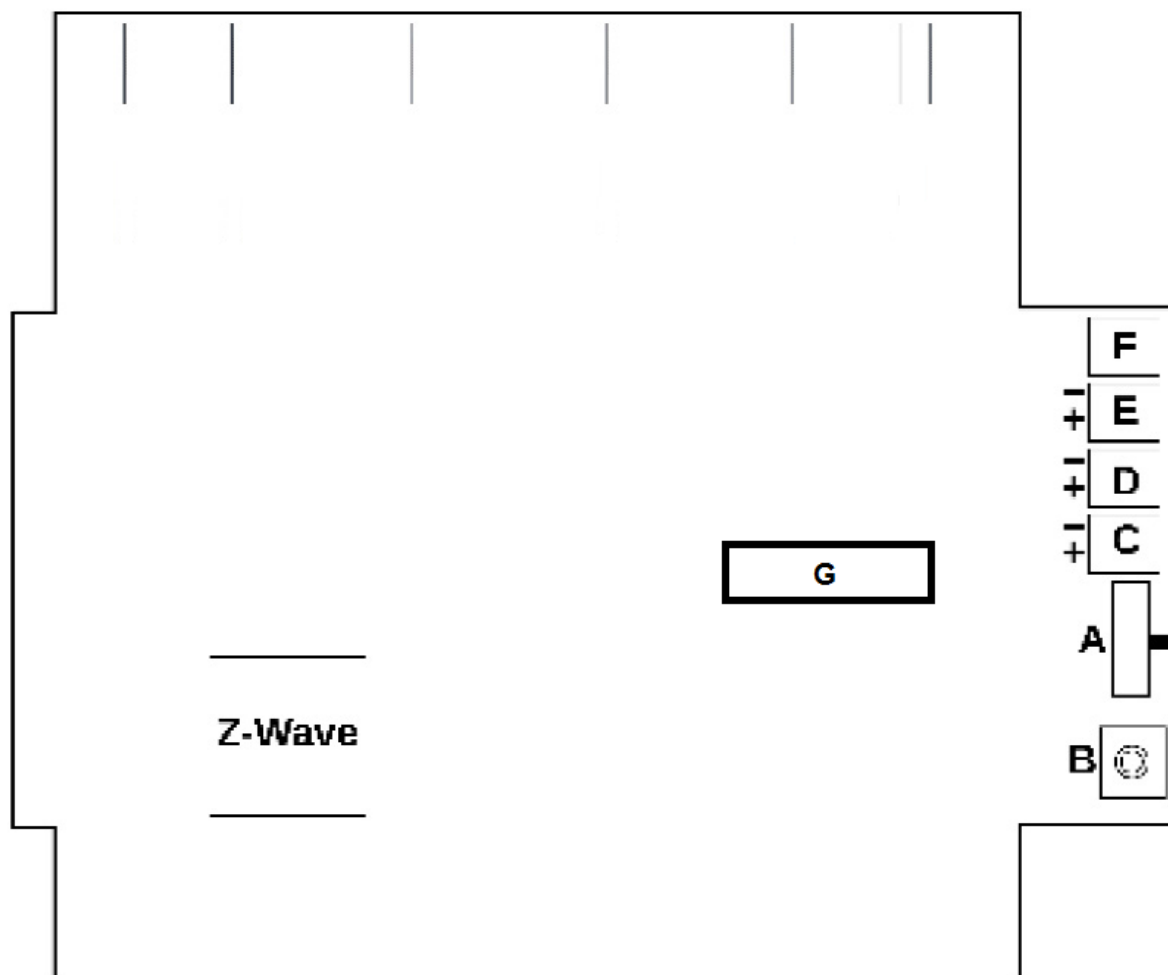

- (A) Power Button
- (B) Z-Wave Button
- (C) Battery Con
- (D) Solar Module Connection
- (E) Charge Connection (12V DC)
- (F) Speaker Connection
- (G) Fuse (Type: 5ET 1.6-R; FUSE GLASS 1.6A 250VAC 5X20MM [Datasheet](#))

Inclusion/Exclusion

On factory default the device does not belong to any Z-Wave network. The device needs to be **added to an existing wireless network** to communicate with the devices of this network. This process is called **Inclusion**.

Devices can also be removed from a network. This process is called **Exclusion**. Both processes are initiated by the primary controller of the Z-Wave network. This controller is turned into exclusion respective inclusion mode. Inclusion and Exclusion is then performed doing a special manual action right on the device.

Inclusion

1. Remove the metal mounting plate from the device.
2. Open the case and turn on the power switch
3. Press the button once.

Exclusion

1. Deactivate the theft protection via parameter 1.
2. Remove the siren from its mount.
3. Open the case.
4. Press the button once.

Product Usage

The siren can be turned on and off using wireless commands. To protect this communication from misuse is strongly recommended to operate the siren in secure communication mode. The secure communication is activated on default during inclusion unless explicitly suppressed. When activated the siren will generate a 105 dB alarm sound and a flash light. This behavior can be configured as well using configuration parameter 5. Make sure to deactivate the tamper protection before removing an included siren from the mounting plate.

It is possible to power the Siren from an external power supply. Please use any 12 V DC power with minimum of 1 W output. The terminals marked with E (see ill1 for more details) allows to connect the power source to the device. its recommended ot detach the cables to the solar cell in this operating mode.

Node Information Frame

The Node Information Frame (NIF) is the business card of a Z-Wave device. It contains information about the device type and the technical capabilities. The inclusion and exclusion of the device is confirmed by sending out a Node Information Frame. Beside this it may be needed for certain network operations to send out a Node Information Frame. To issue a NIF execute the following action: Hit the Z-Wave Button

Quick trouble shooting

Here are a few hints for network installation if things dont work as expected.

1. Make sure a device is in factory reset state before including. In doubt exclude before include.
2. If inclusion still fails, check if both devices use the same frequency.
3. Remove all dead devices from associations. Otherwise you will see severe delays.
4. Never use sleeping battery devices without a central controller.
5. Dont poll FLIRS devices.
6. Make sure to have enough mains powered device to benefit from the meshing

Firmware-Update over the Air

This device is capable of receiving a new firmware 'over the air'. The update function needs to be supported by the central controller. Once the controller starts the update process, perform the following action to confirm the firmware update: For a firmware update you need to open the siren's housing first. Now, you can start the update process with your gateway. Please press the Z-Wave button twice fast, as soon as the single red LED (circuit board under the acrylic glass cover) blinks. The update will take around 10 minutes. After the update, the Siren will activate on. Press the button to disable the siren.

Association - one device controls an other device

Z-Wave devices control other Z-Wave devices. The relationship between one device controlling another device is called association. In order to control a different device, the controlling device needs to maintain a list of devices that will receive controlling commands. These lists are called association groups and they are always related to certain events (e.g. button pressed, sensor triggers, ...). In case the event happens all devices stored in the respective association group will receive the same wireless command wireless command, typically a 'Basic Set' Command.

Association Groups:

Group Number	Maximum Nodes	Description
1	5	Z-Wave Plus Lifeline

Configuration Parameters

Z-Wave products are supposed to work out of the box after inclusion, however certain configuration can adapt the function better to user needs or unlock further enhanced features.

IMPORTANT: Controllers may only allow configuring signed values. In order to set values in the range 128 ... 255 the value sent in the application shall be the desired value minus 256. For example: To set a parameter to 200 it may be needed to set a value of 200 minus 256 = minus 56. In case of a two byte value the same logic applies: Values greater than 32768 may needed to be given as negative values too.

Parameter 1: Siren Tamper Mode

Sets the tamper triggering mode when removed from the holder

Size: 1 Byte, Default Value: 0

Setting	Description
0	Triggers automatically when it is removed from the holder. Must be turned off, using the button or from the controller
1	Triggers automatically when it is removed from the holder and turns off, when placed back on the holder
2	Does not trigger at all, when removed from the holder. Service Mode

Parameter 5: Siren Mode

Determines how the Siren shall react on alarm

Size: 1 Byte, Default Value: 2

Setting	Description
0	Siren Only
1	Flash Only
2	Flash plus Siren

Parameter 6: Auto Off

If the value is set, the siren will be switched off automatically after a defined alarm time in Minutes.

Size: 1 Byte, Default Value: 5

Setting	Description
0	No Auto Off
1 - 127	after X Minutes

Technical Data

Dimensions	300x190x68 mm
Weight	893 gr
Hardware Platform	ZM5202
EAN	0019962005107
IP Class	IP 44
Voltage	12 v
Battery Type	1 * Lithium 2400mAh
Device Type	Siren
Generic Device Class	Binary Switch
Firmware Version	02.04
Z-Wave Version	06.02
Z-Wave Product Id	0154.0004.0002
Frequency	Europe - 868,4 Mhz
Maximum transmission power	5 mW

Supported Command Classes

- Basic
- Switch Binary
- Sensor Binary
- Association Grp Info
- Device Reset Locally
- Zwaveplus Info
- Supervision
- Configuration
- Alarm
- Manufacturer Specific
- Powerlevel
- Firmware Update Md
- Battery
- Association
- Version
- Multi Channel Association
- Security
- Transport Service

Controlled Command Classes

- Transport Service

Explanation of Z-Wave specific terms

- **Controller** — is a Z-Wave device with capabilities to manage the network. Controllers are typically Gateways, Remote Controls or battery operated wall controllers.
- **Slave** — is a Z-Wave device without capabilities to manage the network. Slaves can be sensors, actuators and even remote controls.

- **Primary Controller** — is the central organizer of the network. It must be a controller. There can be only one primary controller in a Z-Wave network.
- **Inclusion** — is the process of adding new Z-Wave devices into a network.
- **Exclusion** — is the process of removing Z-Wave devices from the network.
- **Association** — is a control relationship between a controlling device and a controlled device.
- **Wakeup Notification** — is a special wireless message issued by a Z-Wave device to announce that it is able to communicate.
- **Node Information Frame** — is a special wireless message issued by a Z-Wave device to announce its capabilities and functions.

(c) 2020 Z-Wave Europe GmbH, Antonstr. 3, 09337 Hohenstein-Ernstthal, Germany, All rights reserved, www.zwave.eu. The template is maintained by [Z-Wave Europe GmbH](#). The product content is maintained by Z-Wave Europe GmbH, Supportteam, support@zwave.eu. Last update of the product data: 2020-02-04 13:24:48