

EXP-PP700S-A

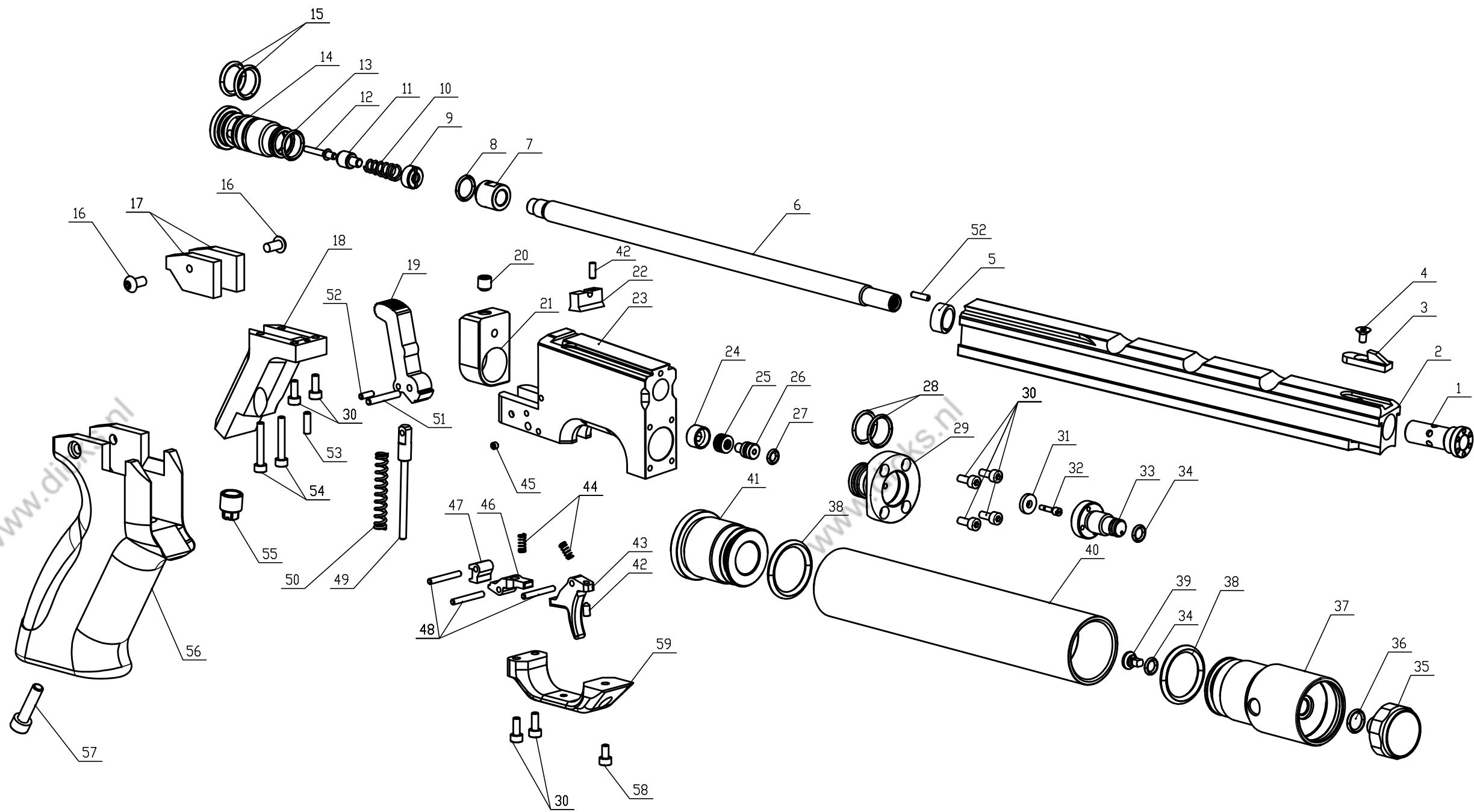

序号	物料编码	零件名称	用量
1	PP700S-005-J-2-A	Barrel Casing Nut	1
2	PP700S-004-J-0-A	Barrel Casing	1
3	PP700S-007-W-2-A	Front Sight	1
4	B-LS-35CrMo-140	Front Sight Screw	1
5	PP700S-003-J-0-A	Barrel Bush	1
6	PP700S-001-J-2-A	Barrel	1
7	PP700W-010-J-00	Barrel Sealing Block	1
8	PP700W-039-X-00	D12-15Barrel Sealing Washer	1
9	PP700W-007-J-00	Valve Nut	1
10	PP700W-034-T-00	Valve Spring	1
11	PP700W-005-J-00	Valve Core	1
12	PP700W-006-J-00	Firing Pin	1
13	PP700W-037-X-00	D14-15Valve Sealing Ring	1
14	PP700W-004-J-00	Valve Body	1
15	PP700W-038-X-00	D16-15Valve Sealing Ring	2
16	PP700W-043-W-00	Grip Screw	2
17	PP700W-012-J-00	Grip Strengthening Block	2
18	PP700W-013-J-00	Connector Block	1
19	PP700W-020-W-00	Hammer	1
20	PP700W-042-W-00	Movable Connector Screw	1
21	PP700W-003-J-00	Movable Connector	1
22	PP700S-006-W-2-A	Front Sight	1
23	PP700S-002-J-0-A	Breech	1
24	PP700W-027-J-00	Constant Valve Nut	1
25	PP700W-032-J-00	Constant Valve Spring	10
26	PP700W-025-J-00	Constant Valve Piston	1
27	M10-059-X-00	D7-15 Sealing Ring	1
28	PP700W-036-X-00	D15-15 Sealing Ring	2
29	PP700W-023-J-00	Constant Valve	1
30	OP12N-082-W-00	Constant Valve Screw	8
31	PP700W-028-J-00	Intake Valve Washer	1
32	PP700W-026-J-00	Intake Valve Needle	1
33	PP700W-024-J-00	Intake Valve Plug	1
34	M10-054-X-00	D8-15Sealing Ring	2
35	M10-060-U-00	Pressure Gauge	1
36	M10-053-X-00	D11-15Sealing Ring	2
37	M10-009-J-00	Intake Valve	1
38	M10-055-X-00	D27-3.1Sealing Ring	2
39	M10-038-W-00	Intake Valve Screw	1
40	PP700W-022-J-00	Air Reservoir	1
41	PP700W-021-J-00	Air Reservoir Connector	1
42	M10-044-W-00	Trigger Screw	2
43	PP700W-017-W-00	Trigger	1
44	PP700W-035-T-00	Trigger Returning Spring	1
45	PP700W-044-W-00	Valve Body Screw	1
46	PP700W-018-W-00	Trigger Assembly	1
47	PP700W-019-W-00	Sear	1
48	PP700W-030-W-00	D2.5-20Trigger Assembly Pin	3
49	PP700W-015-J-00	Hammer Spring Core	1
50	PP700W-033-T-00	Hammer Spring	1
51	PP700W-029-W-00	D3-20Hammer Pin	1
52	PP700W-031-W-00	D2.5-8Hammer Pin	2
53	OP12N-064-W-00	Trigger Assembly Pin	1
54	PP700W-042-W-00	Connector Block Screw	2
55	PP700W-016-J-00	Hammer Spring Screw	1
56	PP700W-011-S-00	Grip	1
57	PP700W-041-W-00	Grip Screw	1
58	OP12N-061-W-00	Trigger Guard Screw	1
59	PP700W-014-J-00	Trigger	1

设计 Designed by _____
 审核 Reviewed by _____
 批准 Approved by _____