



BoWex®

Non-failsafe
curved-tooth gear couplings
types

junior plug-in coupling,
junior M coupling,
M und M...C

|
and their combinations

according to directive 2014/34/EU

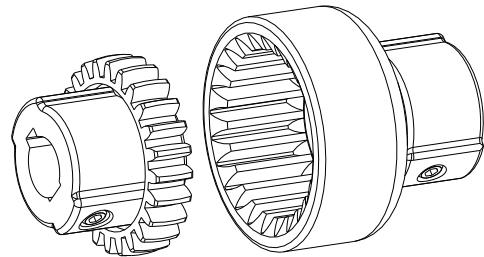

Type junior plug-in coupling (two-part)

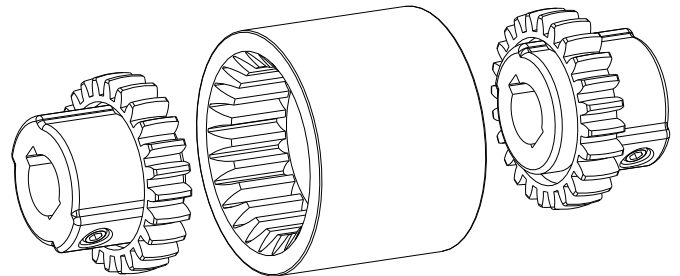

Type junior M coupling (three-part)

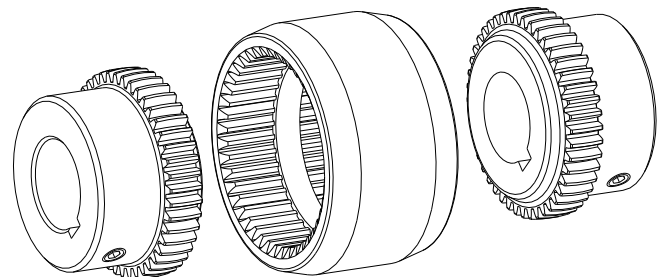



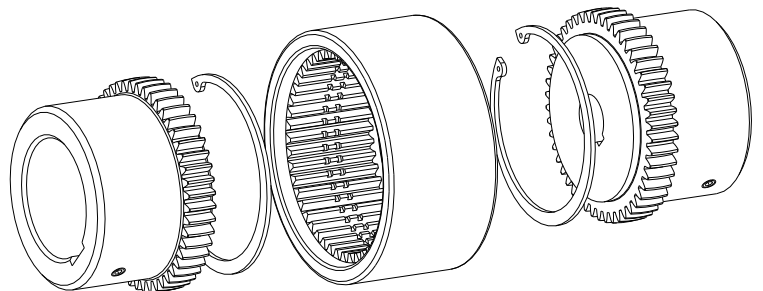

Type M and M...C



Type I

The **BoWex®** curved-tooth gear coupling is a flexible shaft connection. It is able to compensate for shaft misalignment, for example caused by manufacturing inaccuracies, thermal expansion, etc.

Table of contents

1	Technical data	3
2	Advice	5
2.1	General advice	5
2.2	Safety and advice symbols	5
2.3	General hazard warnings	5
2.4	Intended use	6
2.5	Coupling selection	6
2.6	Reference to EC Machinery Directive 2006/42/EC	6
3	Storage, transport and packaging	7
3.1	Storage	7
3.2	Transport and packaging	7
4	Assembly	7
4.1	Components of the couplings	7
4.2	Advice for finish bore	9
4.3	Assembly of the hubs	10
4.4	Displacements - alignment of the couplings	11
5	Start-up	12
6	Breakdowns, causes and elimination	13
7	Disposal	15
8	Spares inventory, customer service addresses	15
9	Enclosure A	
	Advice and instructions regarding the use in  potentially explosive atmospheres	16
9.1	Intended use in  potentially explosive atmospheres	16
9.2	Inspection intervals for couplings in  potentially explosive atmospheres	17
9.3	Inspection of torsional backlash	18
9.4	Standard values of wear	19
9.5	 marking of coupling for potentially explosive atmospheres	20
9.6	EU Certificate of conformity	22

1 Technical data

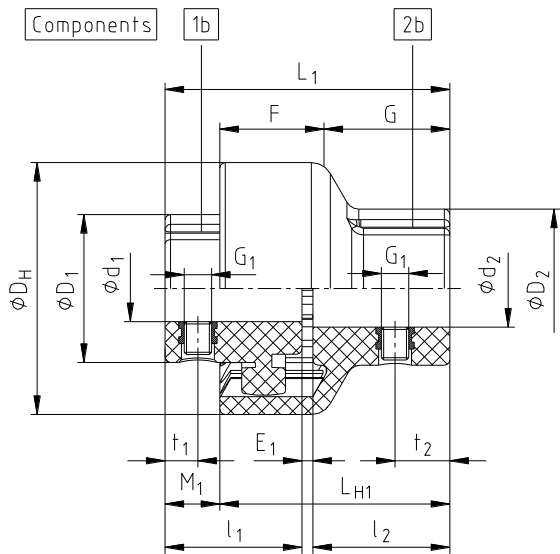

Illustration 1: BoWex® junior plug-in coupling (two-part)

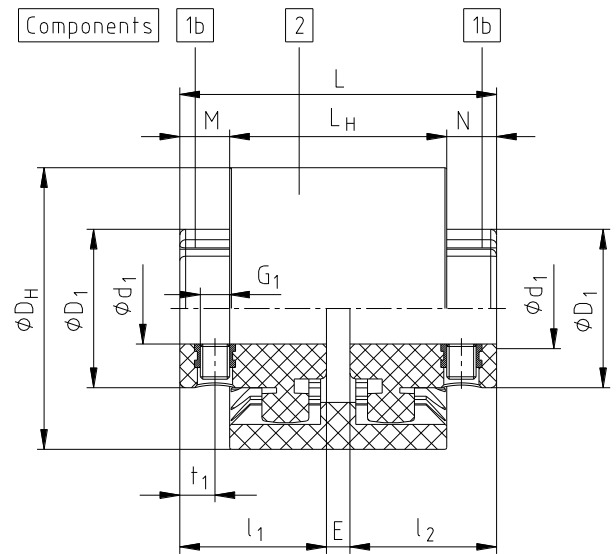

Illustration 2: BoWex® junior M coupling (three-part)

Table 1:

BoWex® junior plug-in coupling and BoWex® junior M coupling

Size	Torque [Nm]		Finish bores [mm]				Setscrew [mm]				Max. speed [rpm]
	T _{KN}	T _{K max}	Hub component 1b d ₁	D ₁	Plug-in sleeve component 2b d ₂	D ₂	G ₁	t ₁	t ₂	T _A [Nm]	
14	5	10	Ø6, Ø7, Ø8, Ø9	22	Ø8	22	M5	6	8	1.4	6000
			Ø10, Ø11	25	Ø10, Ø11	25					
			Ø12, Ø14	26	Ø12, Ø14	26					
19	8	16	Ø12, Ø14	27	Ø14, Ø15	29	M5	6	10	1.4	6000
			Ø16	30							
			Ø19	32	Ø19	35					
24	12	24	Ø10, Ø11, Ø12	26	Ø14, Ø16	32	M5	6	10	1.4	6000
			Ø14, Ø15, Ø16	32							
			Ø18, Ø19, Ø20	36	Ø19, Ø20	36					
			Ø24	38	Ø24	40					

Table 2:

BoWex® junior plug-in coupling and BoWex® junior M coupling

Size	Dimensions [mm]											
	D _H	l ₁ , l ₂	E ₁	L ₁	L _{H1}	M ₁	F	G	E	L	L _H	M, N
14	40	23	2	48	40	8	18.5	21.5	4	50	37	6.5
19	47	25	2	52	42	10	19.0	23.0	4	54	37	8.5
24	53	26	2	54	45	9	21.5	23.5	4	56	41	7.5



1 Technical data

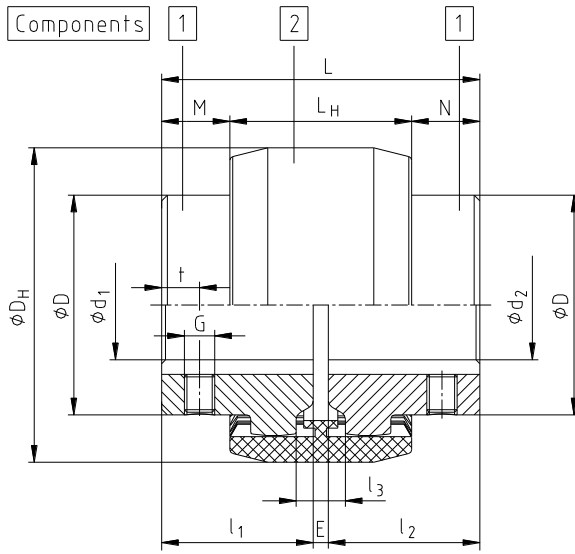

Illustration 3: BoWex® type M

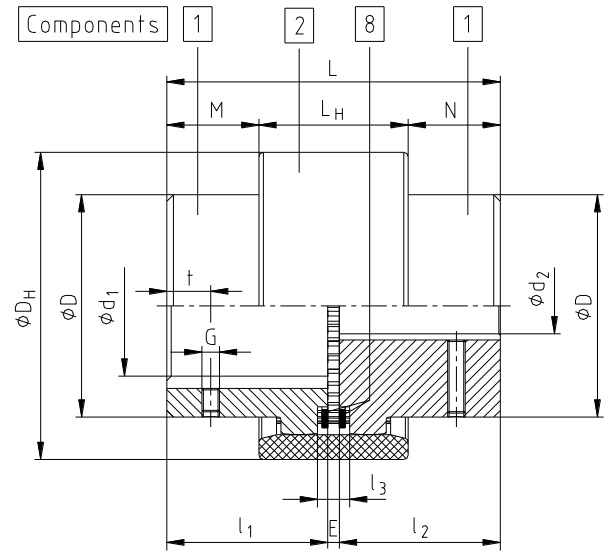

Illustration 4: BoWex® type I

Table 3:

BoWex® type M and type I

Size		Pilot bore		Max. finish bore d_1, d_2	Dimensions [mm]								Setscrew ²⁾ [mm]			
		Un-bored	Pilot bored		l_1, l_2	E	L	L_H	M, N	l_3	D	D_H	D_Z ¹⁾	G	t	T_A [Nm]
M-14	M-14C	x	-	15	23	4	50	37	6.5	10	25	40	33	M5	6	2
M-19	M-19C	x	-	20	25	4	54	37	8.5	10	32	47	39	M5	6	2
M-24	M-24C	x	-	24	26	4	56	41	7.5	14	36	53	45	M5	6	2
M-28	M-28C	x	-	28	40	4	84	46	19	13	44	65	54	M8	10	10
M-32	M-32C	x	-	32	40	4	84	48	18	13	50	75	63	M8	10	10
M-38	M-38C	x	-	38	40	4	84	48	18	13	58	83	69	M8	10	10
M-42		x	-	42	42	4	88	50	19	13	65	92	78	M8	10	10
M-48	M-48C	x	-	48	50	4	104	50	27	13	68	95	78	M8	10	10
M-65	M-65C	x	27 70 lg.	65	55	4	114	68	23	16	96	132	110	M10	15 / 20 ³⁾	17
I-80		-	31	80	90	6	186	93	46.5	20	124	175	145	M10	20	17
I-100		-	35	100	110	8	228	102	63	22	152	210	176	M12	30	40
I-125		-	45	125	140	10	290	134	78	30	192	270	225	M16	40	80

1) Tip circle of hub

2) Position of setscrew BoWex® M-14 to M-24 opposite the keyway; BoWex® M-28 to I-125 on the keyway

3) Length of hub 55 mm t = 15 mm, 70 mm t = 20 mm



BoWex® couplings with attachments that can generate heat, sparks and static charging (e. g. combinations with brake drums, brake disks, overload systems such as torque limiters, fan impellers etc.) are not permitted for the use in potentially explosive atmospheres.

A separate analysis must be performed.

2 Advice

2.1 General advice

Please read through these operating/assembly instructions carefully before you start up the coupling. Please pay special attention to the safety instructions!



The **BoWex®** coupling is suitable and approved for the use in potentially explosive atmospheres. When using the coupling in potentially explosive atmospheres, observe the special advice and instructions regarding safety in enclosure A.

The operating/assembly instructions are part of your product. Please store them carefully and close to the coupling. The copyright for these operating/assembly instructions remains with KTR.

2.2 Safety and advice symbols



Warning of potentially explosive atmospheres

This symbol indicates notes which may contribute to preventing bodily injuries or serious bodily injuries that may result in death caused by explosion.



Warning of personal injury

This symbol indicates notes which may contribute to preventing bodily injuries or serious bodily injuries that may result in death.



Warning of product damages

This symbol indicates notes which may contribute to preventing material or machine damage.



General advice

This symbol indicates notes which may contribute to preventing adverse results or conditions.



Warning of hot surfaces

This symbol indicates notes which may contribute to preventing burns with hot surfaces resulting in light to serious bodily injuries.

2.3 General hazard warnings



With assembly, operation and maintenance of the coupling it has to be made sure that the entire drive train is secured against accidental switch-on. You may be seriously hurt by rotating parts. Please make absolutely sure to read through and observe the following safety indications.

- All operations on and with the coupling have to be performed taking into account "safety first".
- Please make sure to switch off the power pack before you perform your work on the coupling.
- Secure the power pack against accidental switch-on, e. g. by providing warning signs at the place of switch-on or removing the fuse for current supply.
- Do not reach into the operating area of the coupling as long as it is in operation.
- Please secure the coupling against accidental contact. Please provide for the necessary protection devices and covers.

	BoWex® Operating/Assembly instructions	KTR-N 40110 EN Sheet: 6 of 22 Edition: 16
--	---	---

2 Advice

2.4 Intended use

You may only assemble, operate and maintain the coupling if you

- have carefully read through the operating/assembly instructions and understood them
- are technically qualified and specifically trained (e. g. safety, environment, logistics)
- are authorized by your company

The coupling may only be used in accordance with the technical data (see chapter 1). Unauthorized modifications on the coupling design are not admissible. We will not assume liability for any damage that may arise. In the interest of further development we reserve the right for technical modifications.

The **BoWex®** described in here corresponds to the technical status at the time of printing of these operating/assembly instructions.

2.5 Coupling selection



For a long-lasting and failure-free operation of the coupling it must be selected according to the selection instructions (according to DIN 740 part 2) for the particular application (see catalogue drive technology „BoWex®“).

If the operating conditions (performance, speed, modifications on engine and machine) change, the coupling selection must be reviewed.

Please make sure that the technical data regarding torque refer to the sleeve only. The transmittable torque of the shaft-hub-connection must be reviewed by the customer and is subject to his responsibility.

For drives subject to torsional vibrations (drives with cyclic stress due to torsional vibrations) it is necessary to perform a torsional vibration calculation to ensure a reliable selection. Typical drives subject to torsional vibrations are e. g. drives with diesel engines, piston pumps, piston compressors etc. If requested, KTR will perform the coupling selection and the torsional vibration calculation.

2.6 Reference to EC Machinery Directive 2006/42/EC

The couplings supplied by KTR should be considered as components, not machines or partly completed machines according to EC Machinery Directive 2006/42/EC. Consequently KTR does not have to issue a declaration of incorporation. For details about safe assembly, start-up and safe operation refer to the present operating/assembly instructions considering the warnings.

Please observe protection note ISO 16016.	Drawn: 2019-07-01 Pz/Wb	Replacing: KTR-N dated 2017-01-02
	Verified: 2019-07-23 Pz	Replaced by:



3 Storage, transport and packaging

3.1 Storage

The coupling hubs are supplied in preserved condition and can be stored at a dry and roofed place for 6 - 9 months.
The features of the coupling sleeves remain unchanged for up to 5 years with favourable storage conditions.



The storage rooms must not include any ozone-generating devices like e. g. fluorescent light sources, mercury-vapour lamps or electrical high-voltage appliances. Humid storage rooms are not suitable. Please make sure that condensation is not generated. The best relative air humidity is less than 65 %.

3.2 Transport and packaging



In order to avoid any injuries and any kind of damage always make use of proper transport and lifting equipment.

The couplings are packed differently each depending on size, number and kind of transport. Unless otherwise contractually agreed, packaging will follow the in-house packaging specifications of KTR.

4 Assembly

The coupling is generally supplied in individual parts. Before assembly the coupling has to be inspected for completeness.

4.1 Components of the couplings

Type made of nylon

Components of BoWex® junior plug-in coupling

Component	Number	Description
1	1	Hub
2	1	Plug-in sleeve
3	2	Setscrew DIN EN ISO 4029

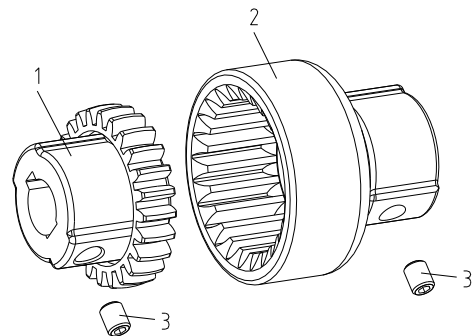

Illustration 5: BoWex® junior plug-in coupling



4 Assembly

4.1 Components of the couplings

Components of BoWex® junior M coupling

Component	Number	Description
1	2	Hub
2	1	Sleeve
3	2	Setscrew DIN EN ISO 4029

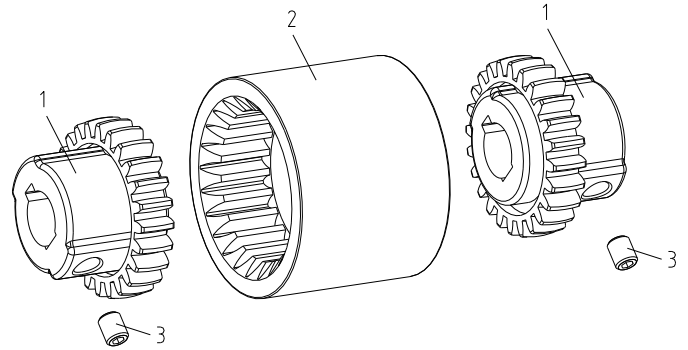

Illustration 6: BoWex® junior M coupling

Type made of steel/nylon

Components of BoWex® M coupling (size 14 - 65)

Component	Number	Description
1	2	Hub
2	1	Sleeve type M
3	2	Setscrew DIN EN ISO 4029

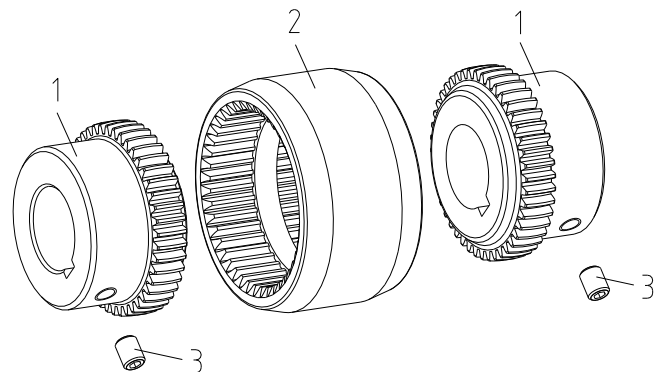

Illustration 7: BoWex® type M

Components of BoWex® I coupling (size 80 - 125)

Component	Number	Description
1	2	Hub
2	1	Sleeve type I ¹⁾
3	2	Seeger Circlip ¹⁾
4	2	Setscrew DIN EN ISO 4029

1) Seeger circlips and sleeve are delivered pre-assembled.

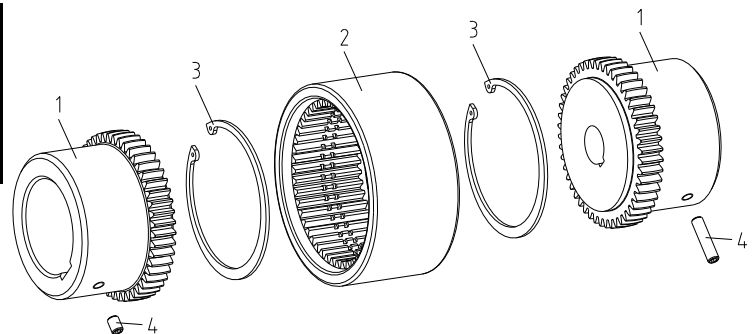

Illustration 8: BoWex® type I

**4 Assembly****4.2 Advice for finish bore**

The maximum permissible bore diameters d (see chapter 1 - technical data) must not be exceeded. If these figures are disregarded, the coupling may tear. Rotating particles may cause danger to life.

- Hub bores (steel hubs) machined by the customer have to observe concentricity or axial run-out, respectively (see illustration 9).
- Please make absolutely sure to observe the figures for $\varnothing d_{max}$.
- Carefully align the hubs when the finish bores are drilled.
- Please provide for a setscrew according to DIN EN ISO 4029 with a cup point or an end plate to fasten the hubs axially.

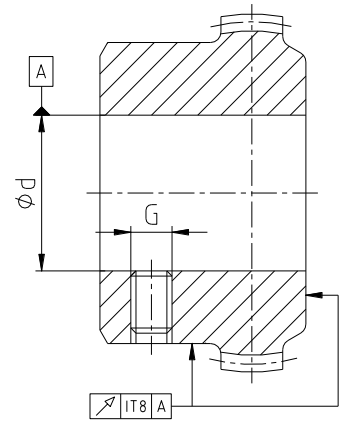

Illustration 9: Concentricity and axial run-out



The customer bears the sole responsibility for all machining processes performed subsequently on unbored or pilot bored as well as finish machined coupling components and spare parts. KTR does not assume any warranty claims resulting from insufficient remachining.



KTR supplies unbored or pilot bored coupling components and spare parts only upon explicit request of the customer. These parts are additionally marked with the symbol .

Reference to unbored resp. pilot bored coupling components with explosion protection marking:

Basically the company KTR supplies couplings resp. coupling hubs with explosion protection marking as an unbored or pilot bored type only on explicit request of the customer. The prerequisite is a declaration of exemption submitted by the customer assuming any responsibility and liability for remachining performed properly.

Table 4: Setscrew DIN EN ISO 4029

Size	14 ¹⁾	19 ¹⁾	24 ¹⁾	28	32	38	42	48	65	80	100	125
Dimension G	M5	M5	M5	M8	M8	M8	M8	M8	M10	M10	M12	M16
Tightening torque T_A [Nm]	2	2	2	10	10	10	10	10	17	17	40	80

1) Tightening torques of BoWex® junior plug-in coupling and BoWex® junior M coupling $T_A = 1.4$ Nm

Table 5: Recommended fit pairs acc. to DIN 748/1

Bore [mm]		Shaft tolerance	Bore tolerance
above	up to		
	50	k6	H7 (KTR standard)
50		m6	

If a feather keyway is intended to be used in the hub, it should correspond to the tolerance ISO JS9 (KTR standard) with standard operating conditions or ISO P9 with complicated operating conditions (frequently alternating torsional direction, shock loads, etc.).

The transmittable torque of the shaft-hub-connection must be reviewed by the customer and is subject to his responsibility.

4 Assembly

4.3 Assembly of the hubs



We recommend to inspect bores, shaft, keyway and feather key for dimensional accuracy before assembly.



Heating the hubs lightly (approx. 80 °C) allows for an easier mounting on the shaft.



Please pay attention to the ignition risk in potentially explosive atmospheres!



Touching the heated hubs causes burns.
Please wear safety gloves.



With the assembly make sure that the distance dimension E (see table 2 and 3) is observed to allow for axial clearance of the sleeve while being in operation.
Disregarding this advice may cause damage to the coupling.



If used in potentially explosive atmospheres the setscrews to fasten the hubs as well as all screw connections must be secured against working loose additionally, e. g. conglomerating with Loctite (average strength).

- Mount the hubs on the shaft of driving and driven side.
- **Does not apply with type BoWex® junior plug-in coupling:**
Put the sleeve onto the spline of the hub on the driving or driven side.
- Shift the power packs in axial direction until the distance dimension E is achieved.
- If the power packs are already firmly assembled, shifting the hubs axially on the shafts allows for setting the distance dimension E.
- Fasten the hubs by tightening the setscrews DIN EN ISO 4029 with a cup point (tightening torques see table 4).

4 Assembly

4.4 Displacements - alignment of the couplings

The displacement figures specified in tables 6 and 7 provide for sufficient safety to compensate for external influences like, for example, thermal expansion or foundation settling.



In order to ensure a long service life of the coupling and avoid dangers with the use in potentially explosive atmospheres, the shaft ends must be accurately aligned. Please absolutely observe the displacement figures specified (see tables 6 and 7). If the figures are exceeded, the coupling will be damaged. The more accurate the alignment of the coupling, the longer is its service life. If used in potentially explosive atmospheres for explosion group IIC, only half of the displacement figures (see tables 6 and 7) is permissible.

Please note:

- The displacement figures specified in tables 6 and 7 are maximum figures which must not arise in parallel. If radial and angular displacement arise at the same time, the permissible radial displacements of the coupling halves have to be reduced as follows:

$$\Delta K_{r_{zul}} = \Delta K_r - \frac{\Delta K_r}{2\Delta K_w} \cdot \Delta W_w$$

ΔW_w = angular shaft displacement

- The displacement figures specified are general standard figures that apply up to an ambient temperature of 80 °C, ensuring a sufficient service life of the **BoWex®** coupling. Displacement figures between the speeds specified have to be interpolated accordingly. If necessary, ask about the displacement for the corresponding coupling type.
- Please inspect with a dial gauge, ruler or feeler whether the permissible displacement figures of tables 6 and 7 can be observed.

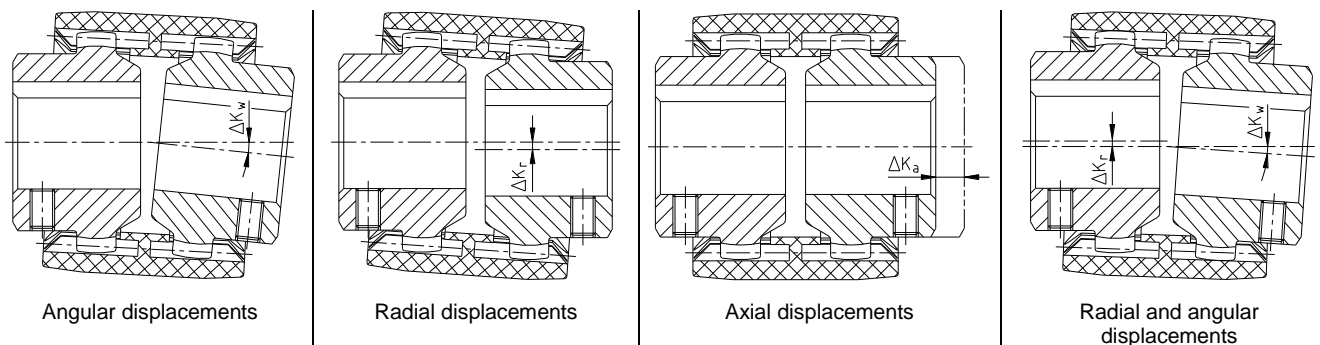

Illustration 10: Displacements

Examples of the displacement combinations specified in illustration 11:

Example 1:
 $\Delta K_r = 30 \%$
 $\Delta K_w = 70 \%$

Example 2:
 $\Delta K_r = 60 \%$
 $\Delta K_w = 40 \%$

Illustration 11:
Combinations of displacement

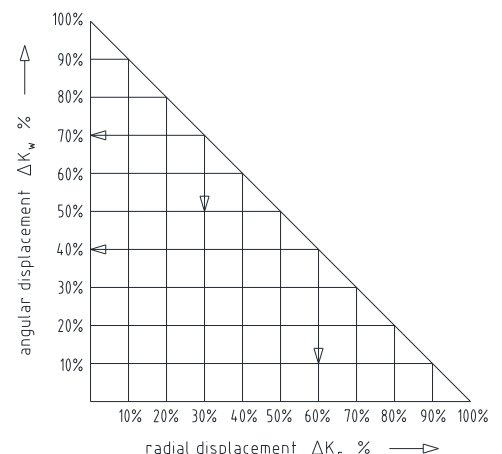

$\Delta K_{total} = \Delta K_r + \Delta K_w \leq 100 \%$
--

Please observe protection note ISO 16016.	Drawn: 2019-07-01 Pz/Wb	Replacing: KTR-N dated 2017-01-02
	Verified: 2019-07-23 Pz	Replaced by:

**4 Assembly****4.4 Displacements - alignment of the couplings****Table 6: Displacement figures - BoWex® junior plug-in coupling and BoWex® junior M coupling**

Size	Type junior plug-in coupling			Type junior M		
	14	19	24	14	19	24
Max. axial displacement ΔK_a [mm]	± 1	± 1	± 1	± 1	± 1	± 1
Max. radial displacement with $n=1500$ rpm ΔK_r [mm]	± 0.1	± 0.1	± 0.1	± 0.3	± 0.3	± 0.4
Max. radial displacement with $n=3000$ rpm ΔK_r [mm]	± 0.1	± 0.1	± 0.1	± 0.3	± 0.3	± 0.4
ΔK_w [degree] max. angular displacement with $n=1500$ rpm	± 1.0	± 1.0	± 0.9	± 1.0	± 1.0	± 0.9
ΔK_w [degree] max. angular displacement with $n=3000$ rpm	± 0.7	± 0.7	± 0.6	± 0.7	± 0.7	± 0.6

Table 7: Displacement figures - BoWex® type M and type I

Size	14	19	24	28	32	38	42	48	65	80	100	125
Max. axial displacement ΔK_a [mm]	± 1	± 1	± 1	± 1	± 1	± 1	± 1	± 1	± 1	± 1	± 1	± 1
Max. radial displacement with $n=1500$ rpm ΔK_r [mm]	± 0.30	± 0.30	± 0.35	± 0.35	± 0.35	± 0.40	± 0.40	± 0.40	± 0.45	± 0.45	± 0.45	± 0.45
Max. radial displacement with $n=3000$ rpm ΔK_r [mm]	± 0.20	± 0.20	± 0.23	± 0.23	± 0.23	± 0.25	± 0.25	± 0.25	± 0.28	± 0.28	± 0.28	± 0.28
ΔK_w [degree] max. angular displacement with $n=1500$ rpm	± 1.0	± 1.0	± 0.9	± 0.9	± 0.9	± 0.9	± 0.9	± 0.9	± 0.7	± 0.6	± 0.6	± 0.4
ΔK_w [degree] max. angular displacement with $n=3000$ rpm	± 0.7	± 0.7	± 0.6	± 0.6	± 0.6	± 0.6	± 0.6	± 0.6	± 0.5	± 0.4	± 0.4	± 0.3

5 Start-up

Before start-up of the coupling, inspect the tightening of the setscrews in the hubs, the alignment and the distance dimension E and adjust, if necessary, and also inspect all screw connections for the tightening torques specified.



If used in potentially explosive atmospheres the setscrews to fasten the hubs as well as all screw connections must be secured against working loose additionally, e. g. conglomerating with Loctite (average strength).

Finally the coupling protection against accidental contact must be fitted. It is required in accordance with DIN EN ISO 12100 (Safety of Machinery) and directive 2014/34/EU and must protect against

- access with the little finger
- falling down of solid foreign objects.

The cover may provide for openings intended for necessary heat dissipation. These openings have to comply with DIN EN ISO 13857.

The cover must be electrically conductive and included in the equipotential bonding. Bellhousings (magnesium share below 7.5 %) made of aluminium and damping rings (NBR) can be used as connecting element between pump and electric motor. The cover may only be taken off with standstill of the unit.

**5 Start-up**

If the couplings are used in locations subject to dust explosion and in mining the user must make sure that there is no accumulation of dust in a dangerous volume between the cover and the coupling. The coupling must not operate in an accumulation of dust.

For covers with unlocked openings on the top face no light metals must be used if the couplings are used as equipment of equipment group II (*if possible, from stainless steel*). If the couplings are used in mining (equipment group I M2), the cover must not be made of light metal. In addition, it must be resistant to higher mechanical loads than with use as equipment of equipment group II.

During operation of the coupling, please pay attention to

- different operating noise
- vibrations occurring.



If you note any irregularities with the coupling during operation, the drive unit must be switched off immediately. The cause of the breakdown must be specified by means of the table „Breakdowns“ and, if possible, be eliminated according to the proposals. The potential breakdowns specified can be hints only. To find out the cause all operating factors and machine components must be considered.

Coating of coupling:

If coated (priming, paintings, etc.) couplings are used in potentially explosive atmospheres, the requirements on conductivity and coating thickness must be considered. With paintings up to 200 µm electrostatic load does not have to be expected. Paintings and coatings exceeding a thickness of 200 µm are generally impermissible for potentially explosive atmospheres. It also applies for multiple coatings exceeding an overall thickness of 200 µm. Make sure with painting or coating that the coupling components are conductively connected with the device/devices to be connected so that the equipotential bonding is not impeded by the paint or coat applied. In addition, make sure that the marking of the coupling remains legible. Painting or coating of the sleeve is generally not admitted.

6 Breakdowns, causes and elimination

The below-mentioned failures can result in a use of the **BoWex®** coupling other than intended. In addition to the specifications given in these operating/assembly instructions make sure to avoid such failures.

The errors listed can only be clues to search for the failures. When searching for the failure the adjacent components must generally be considered.



If used other than intended the coupling can become a source of ignition. EU directive 2014/34/EU requires special care by the manufacturer and the user.

**6 Breakdowns, causes and elimination****General failures with use other than intended:**

- Important data for the coupling selection are not forwarded.
- The calculation of the shaft-hub-connection is not considered.
- Coupling components with damage occurred during transport are assembled.
- If the heated hubs are assembled, the permissible temperature is exceeded.
- The clearance of the components to be assembled is not coordinated with one another.
- Tightening torques have been fallen below/exceeded.
- Components are mixed up by mistake/assembled incorrectly.
- No original **KTR** components (purchased parts) are used.
- Old/already worn out sleeves or sleeves stored for too long are used.
- Maintenance intervals are not observed.

Breakdowns	Causes	Hazard notes for potentially explosive atmospheres	Elimination
Different operating noise and/or vibrations occurring	Micro friction by faulty alignment on the spline of the nylon sleeve	Danger of ignition due to hot surfaces	1) Set the unit out of operation 2) Eliminate the reason for the misalignment (e. g. loose foundation bolts, breaking of the engine mount, heat expansion of unit components, modification of the installation dimension E of the coupling) 3) For inspection of wear see chapter 9.2
	Screws for axial fastening of hubs working loose		1) Set the unit out of operation 2) Inspect alignment of coupling 3) Tighten the screws to fasten the hubs and secure against working loose 4) For inspection of wear see chapter 9.2
Breaking of the nylon sleeve/spline	Breaking of the nylon sleeve/spline due to high shock energy/overload	none	1) Set the unit out of operation 2) Disassemble the coupling and remove remainders of the nylon sleeve 3) Inspect coupling components and replace coupling components that have been damaged 4) Insert nylon sleeve, assemble coupling components 5) Find out the reason for overload
	Operating parameters do not meet with the performance of the coupling		1) Set the unit out of operation 2) Review the operating parameters and select a bigger coupling (consider mounting space) 3) Assemble new coupling size 4) Inspect alignment
	Operating error of the unit		1) Set the unit out of operation 2) Disassemble the coupling and remove remainders of the nylon sleeve 3) Inspect coupling components and replace coupling components that have been damaged 4) Insert nylon sleeve, assemble coupling components 5) Instruct and train the service staff
Excessive wear on the spline of sleeve	Vibrations of drive	Danger of ignition due to hot surfaces	1) Set the unit out of operation 2) Disassemble the coupling and remove remainders of the nylon sleeve 3) Inspect coupling components and replace coupling components that have been damaged 4) Insert nylon sleeve, assemble coupling components 5) Inspect alignment, adjust if necessary 6) Find out the reason for vibrations

**6 Breakdowns, causes and elimination**

Breakdowns	Causes	Hazard notes for potentially explosive atmospheres	Elimination
Excessive wear on the spline of sleeve	ambient/contact temperatures which are too high for the sleeve, max. permissible -30 °C/+100 °C	Danger of ignition due to hot surfaces	<ol style="list-style-type: none"> 1) Set the unit out of operation 2) Disassemble the coupling and remove remainders of the nylon sleeve 3) Inspect coupling components and replace coupling components that have been damaged 4) Insert nylon sleeve, assemble coupling components 5) Inspect alignment, adjust if necessary 6) Inspect and adjust ambient/contact temperature
	e. g. contact with aggressive liquids/oils, ozone influence, too high/low ambient temperatures etc. causing a physical modification of the nylon sleeve	none	<ol style="list-style-type: none"> 1) Set the unit out of operation 2) Disassemble the coupling and remove remainders of the nylon sleeve 3) Inspect coupling components and replace coupling components that have been damaged 4) Insert nylon sleeve, assemble coupling components 5) Inspect alignment, adjust if necessary 6) Make sure that further physical modifications of the sleeve are excluded



If you operate with a worn sleeve (see chapter 9.3 and 9.4) a proper operation is not ensured.

7 Disposal

In respect of environmental protection we would ask you to dispose of the packaging or products on termination of their service life in accordance with the legal regulations and standards that apply, respectively.

- **Metal**
Any metal components have to be cleaned and disposed of by scrap metal.
- **Nylon materials**
Nylon materials have to be collected and disposed of by a waste disposal company.

8 Spares inventory, customer service addresses

We recommend to store major spare parts on site to ensure the readiness for use of the machine in case if a coupling fails.

Contact addresses of the KTR partners for spare parts and orders can be obtained from the KTR homepage at www.ktr.com.



KTR does not assume any liability or warranty for the use of spare parts and accessories which are not provided by KTR and for the damages which may incur as a result.

Please observe protection note ISO 16016.	Drawn: 2019-07-01 Pz/Wb	Replacing: KTR-N dated 2017-01-02
	Verified: 2019-07-23 Pz	Replaced by:

**9 Enclosure A**Advice and instructions regarding the use in  potentially explosive atmospheresEnclosure A only valid for BoWex® coupling.**9.1 Intended use in  potentially explosive atmospheres**Conditions of operation in  potentially explosive atmospheres

BoWex® couplings are suitable for the use according to EU directive 2014/34/EU.

1. Industry (with the exception of mining)

- Equipment group II of category 2 and 3 (*coupling is not approved/not suitable for equipment group 1*)
- Substance group G (gases, fogs, vapours), zone 1 and 2 (*coupling is not approved/not suitable for zone 0*)
- Substance group D (dusts), zone 21 and 22 (*coupling is not approved/not suitable for zone 20*)
- Explosion group IIC (gases, fogs, vapours) (*explosion group IIA and IIB are included in IIC*) and explosion group IIIC (dusts) (*explosion group IIIA and IIIB are included in IIIC*)

Temperature class:

Temperature class	Standard sleeve „light“ Conductive sleeve „black“	
	Ambient or operating temperature T _a ¹⁾	Max. surface temperature ²⁾
T4	-30 °C to +100 °C	+120 °C
T5	-30 °C to +75 °C	+95 °C
T6	-30 °C to +60 °C	+80 °C

Explanation:

The maximum surface temperatures result from each the maximum permissible ambient or operating temperature T_a plus the maximum temperature increase ΔT of 20 K (standard sleeve "light" and conductive sleeve "black") to be considered. A relevant standard safety margin of 5 K has to be added to the temperature class.

- 1) The ambient or operating temperature T_a is limited to + 100 °C (standard sleeve "light" and conductive sleeve "black") due to the permissible permanent operating temperature of the BoWex® sleeves used.
- 2) The maximum surface temperature of +120 °C applies for the use in locations which are potentially subject to dust explosion.

In potentially explosive atmospheres

- the ignition temperature of dusts generated must at least be 1.5 times the surface temperature to be considered
- the glow temperature must at least be the surface temperature to be considered plus a safety distance of 75 K.
- the gases and vapours generated must amount to the temperature class specified.

2. MiningEquipment group I of category M2 (*coupling is not approved/not suitable for equipment group M1*)

Permissible ambient temperature - 30 °C to + 100 °C (standard sleeve "light" and conductive sleeve "black").

9 Enclosure A

Advice and instructions regarding the use in  potentially explosive atmospheres

9.2 Inspection intervals for couplings in  potentially explosive atmospheres

Equipment category	Inspection intervals
M2 2G 2D no gases and vapours of explosion group IIC	The torsional backlash of the coupling (see chapter 9.3 and 9.4) according to directive 2014/34/EU only has to be inspected if a failure of the coupling and consequently a standstill of the drive causes explosion hazard. We recommend a preventive inspection of circumferential backlash and visual inspection of the sleeve. This should be performed after 3,000 operating hours for the first time, at the latest 6 months after start-up of the coupling. If you note insignificant or no wear on the sleeve upon this initial inspection, further inspections can each be performed after 6,000 operating hours or at the latest after 18 months, provided that the operating parameters remain the same. If you note significant wear during the initial inspection so that it would be recommendable to replace the sleeve, please find out the cause according to the table „Breakdowns“, if possible. The maintenance intervals must be adjusted to the modified operating parameters without fail.
M2 2G 2D Gases and vapours of explosion group IIC	The torsional backlash of the coupling (see chapter 9.3 and 9.4) according to directive 2014/34/EU only has to be inspected if a failure of the coupling and consequently a standstill of the drive causes explosion hazard. We recommend a preventive inspection of circumferential backlash and visual inspection of the sleeve. This should be performed after 2,000 operating hours for the first time, at the latest 3 months after start-up of the coupling. If you note insignificant or no wear on the sleeve upon this initial inspection, further inspections can each be performed after 4,000 operating hours or at the latest after 12 months, provided that the operating parameters remain the same. If you note significant wear during the initial inspection so that it would be recommendable to replace the sleeve, please find out the cause according to the table „Breakdowns“, if possible. The maintenance intervals must be adjusted to the modified operating parameters without fail.

BoWex® coupling

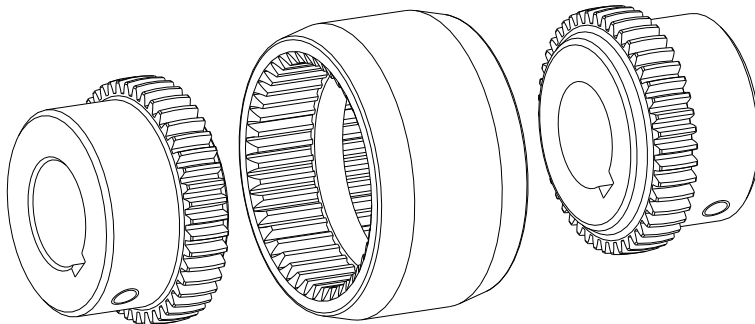

Illustration 12: BoWex® coupling

Here the backlash between the hub and the nylon spline must be inspected via torsional backlash, each separately from the driving and the driven side.

The friction/wear may only be X_{max} of the original spline thickness before the nylon sleeves must be replaced.

When reaching the torsional backlash ΔS_{max} , the nylon sleeve must be replaced immediately, irrespective of the inspection intervals.



9 Enclosure A

Advice and instructions regarding the use in  potentially explosive atmospheres

9.3 Inspection of torsional backlash



To inspect the torsional backlash the power pack which is switched off needs to be secured against accidental switch-on.

Driving side

- Turn the hub opposite the direction of drive.



Here the sleeve must not be axially displaced from its position of wear.

- Mark sleeve and hub (see Illustration 13).
- Turn the hub in the driving direction and measure the torsional backlash ΔS_{max} .
- When reaching the torsional backlash ΔS_{max} . the nylon sleeve must be replaced.

Driven side

- Turn the hub in the direction of the drive.



Here the sleeve must not be axially displaced from its position of wear.

- Mark sleeve and hub (see Illustration 13).
- Turn the hub in the opposite drive direction and measure the torsional backlash ΔS_{max} .
- When reaching the torsional backlash ΔS_{max} . the nylon sleeve must be replaced.

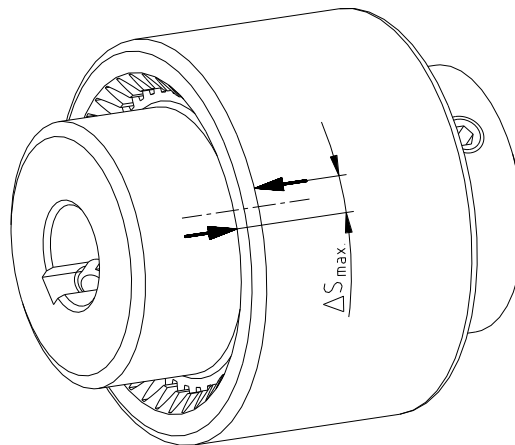

Illustration 13: Marking of sleeve and hub

9 Enclosure A

Advice and instructions regarding the use in  potentially explosive atmospheres

9.4 Standard values of wear

If the torsional backlash is $\geq \Delta S_{max.}$ [mm] / friction $\geq X_{max.}$ [mm], the nylon sleeves must be replaced.

Reaching the limits for replacing depends on the operating conditions and the existing operating parameters.



In order to ensure a long service life of the coupling and avoid dangers with the use in potentially explosive atmospheres, the shaft ends must be accurately aligned. Please absolutely observe the displacement figures specified (see tables 6 and 7). If the figures are exceeded, the coupling will be damaged.

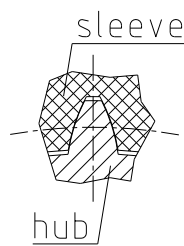

Illustration 14: Sleeve in new condition

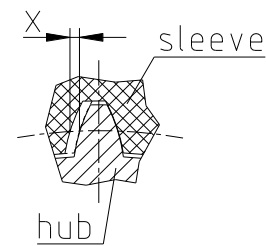

Illustration 15: Wear of sleeve

Table 8:

Size	Limits of wear each hub		Size	Limits of wear each hub	
	Wear $X_{max.}$ [mm]	Torsional backlash $\Delta S_{max.}$ [mm]		Wear $X_{max.}$ [mm]	Torsional backlash $\Delta S_{max.}$ [mm]
14	0.8	1.3	45	1.0	1.8
19	0.8	1.4	48	1.0	1.8
24	1.0	1.5	65	1.4	2.5
28	1.0	1.6	80	1.6	2.7
32	1.0	1.7	100	1.8	3.1
38	1.0	1.7	125	2.0	3.5
42	1.0	1.7			



9 Enclosure A

Advice and instructions regarding the use in  potentially explosive atmospheres

9.5  marking of coupling for potentially explosive atmospheres

The ATEX marking of the BoWex® curved-tooth gear coupling is applied on the outer sheath or on the front side.
For the complete marking refer to the operating/assembly instructions and/or the delivery note/package.

The following marking applies for the products:

- Type M with standard sleeve (light), sizes M-14 and M-19
- Type S..-St with standard sleeve (light), sizes S14-St to S24-St inclusive
- Type M with conductive sleeve (black), sizes M-14C to M-80C inclusive
- Type SSR with Seeger circlips with conductive sleeve (black), sizes 24 SSR to 125 SSR inclusive
- Type S..-St with conductive sleeve (black), sizes S14-St to S55-St inclusive

BoWex®
<Year>



I	M2	Ex	h	I					Mb
II	2G	Ex	h	IIC	T6	...	T4		Gb
II	2D	Ex	h	IIIC	T80 °C	...	T120 °C		Db
					-30 °C ≤ T _a ≤ +60 °C	...	+100 °C		

KTR Systems GmbH, Carl-Zeiss-Straße 25, D-48432 Rheine

- Type M with standard sleeve (light), sizes M-24 to M-65 inclusive
- Type SSR with Seeger circlips with standard sleeve (light), sizes 24 SSR to 45 SSR inclusive
- Type S..-St with standard sleeve (light), sizes S28-St to S55-St inclusive

BoWex®
<Year>



I	M2	Ex	h	I					Mb
II	2G	Ex	h	IIB	T6	...	T4		Gb
II	2D	Ex	h	IIIC	T80 °C	...	T120 °C		Db
					-30 °C ≤ T _a ≤ +60 °C	...	+100 °C		

KTR Systems GmbH, Carl-Zeiss-Straße 25, D-48432 Rheine

Short marking:

(A short marking is only made if not possible differently for reason of space or functioning.)

BoWex®
<Year>



Deviating marking applies until 31st October 2019:

Short marking:



II 2GD c IIC T X/I M2 c X

Complete marking:



II 2G c IIC T6, T5 resp. T4
 -30 °C ≤ T_a ≤ +65 °C, +80 °C resp. +100 °C
 II 2D c T 120 °C -30 °C ≤ T_a ≤ +100 °C
 I M2 c -30 °C ≤ T_a ≤ +100 °C

Please observe protection note ISO 16016.	Drawn:	2019-07-01 Pz/Wb	Replacing:	KTR-N dated 2017-01-02
	Verified:	2019-07-23 Pz	Replaced by:	



9 Enclosure A

Advice and instructions regarding the use in  potentially explosive atmospheres



9.5  marking of coupling for potentially explosive atmospheres

Substance group - gases, fogs and vapours:

The marking with explosion group IIC includes the explosion groups IIA and IIB.

Substance group - dusts:

The marking with explosion group IIIC includes the explosion groups IIIA and IIIB.

If the symbol  was punched in addition to marking , the coupling component was supplied by KTR as an unbored or pilot bored version (see chapter 4.2 of the present operating/assembly instructions).



9 Enclosure A

Advice and instructions regarding the use in  potentially explosive atmospheres

9.6 EU Certificate of conformity

EU Certificate of conformity

corresponding to EU directive 2014/34/EU dated 26 February 2014 and to the legal regulations

The manufacturer - KTR Systems GmbH, D-48432 Rheine - states that the

BoWex® curved-tooth gear couplings®

in an explosion-proof design described in these operating/assembly instructions are devices corresponding to article 2, 1. of directive 2014/34/EU and comply with the general safety and health requirements according to enclosure II of directive 2014/34/EU.

The coupling described in here complies with the specifications of the following standards/rules:

- DIN EN ISO 80079-36
- DIN EN ISO 80079-37
- DIN EN ISO 80079-38
- IEC/TS 60079-32-1

The BoWex® is in accordance with the specifications of directive 2014/34/EU.

According to article 13 (1) b) ii) of directive 2014/34/EU the technical documentation is deposited with the notified body (type examination certificate IBExU13ATEXB007 X:

IBExU
 Institut für Sicherheitstechnik GmbH
 Identification number: 0637
 Fuchsmühlenweg 7
 09599 Freiberg

Rheine,
Place

2019-07-01
Date

 i. V.
 Reinhard Wibbeling
 Engineering/R&D

 i. A.
 Andreas Hücker
 Product Manager