

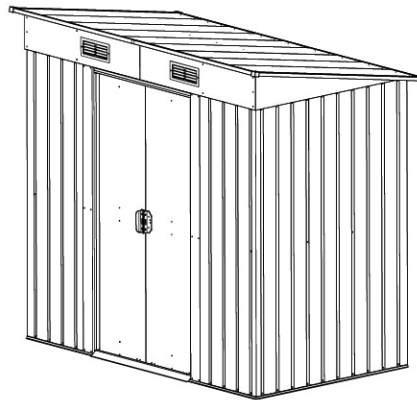

Deuba® Gerätehaus Metall



Artikelnummer:
990736 /990737

Der direkte Weg zu unseren neusten Produkten, Angeboten und
vieles mehr!



Scan me

Deuba Serviceportal

Für jede Art Service, Reklamationen und technischen Support können Sie sich
vertrauensvoll an unsere geschulten Mitarbeiter wenden.

www.Deubaservice.de

Hergestellt für:
Deuba GmbH & Co. KG
Zum Wiesenhof 84
66663 Merzig
Germany



ANLEITUNG



ACHTUNG! Beachten Sie die Sicherheitshinweise und Aufbauanweisungen, um das Risiko von Verletzungen oder Beschädigungen am Produkt zu vermeiden.



Wichtig: Lesen Sie vor der ersten Verwendung die Anleitung vollständig und gründlich durch. Bewahren Sie diese Anleitung zum späteren Nachschlagen auf. Sollten Sie eines Tages das Produkt weitergeben, achten Sie darauf, auch diese Anleitung weiterzugeben.



Nur für den Hausgebrauch und nicht für gewerbliche Nutzung geeignet.



Halten Sie kleine Teile und Verpackungsmaterial von Kindern fern! Erstickungsgefahr!
Prüfen Sie den Lieferumfang auf Vollständigkeit. Spätere Reklamationen können nicht akzeptiert werden.

Prüfen Sie alle Elemente und Teile auf Schäden. Trotz sorgfältiger Kontrollen kann es passieren, dass auch die beste Ware auf dem Transportweg Schaden nimmt. Bauen Sie in solch einem Fall Ihr Produkt nicht auf. Defekte Teile können Gefahren und Gesundheitsschäden nach sich ziehen.



Nehmen Sie niemals Änderungen am Produkt vor! Durch Änderungen erlischt die Garantie und das Produkt kann unsicher bzw. schlimmstenfalls sogar gefährlich werden.

Packen Sie alle Teile und Elemente des Sets aus und platzieren Sie die Komponenten auf der Oberseite des Kartons oder einer anderen sauberen Oberfläche. Dies schützt Ihr neues Produkt.

Achten Sie dabei auch darauf, den Boden nicht zu verkratzen, wenn Sie mit Werkzeugen arbeiten.

Stellen Sie sicher, dass dieses Produkt vor Gebrauch vollständig montiert ist.

Standortauswahl

Bevor Sie mit dem Aufbau beginnen, machen Sie sich mit den lokalen Bestimmungen und Verordnungen vertraut. Achten Sie bei der Auswahl des geeignetsten Orts für das Aufstellen des Gerätehauses auf einen stabilen, geraden Platz als Untergrund und achten Sie unbedingt darauf, dass keine exponierte Stelle gewählt wird, wo das Gerätehaus vollständig frei steht! Ein gewisser Schutz vor Stürmen und stürmischen Böen muss gewährleistet sein. Frei stehend wird es sonst zu einem Schaden kommen.

Hinweise

Bevor Sie mit dem Aufbau beginnen, machen Sie sich mit den lokalen Bestimmungen und Verordnungen vertraut. Suchen Sie sich einen festen und geraden Platz als Untergrund. Stellen Sie das Haus nur bei trockenem schönem Wetter auf. Nicht bei starkem Wind aufstellen!

Wenn möglich, stellen Sie das Gartenhaus mit 3 oder mehr Personen gemeinsam auf. Anderfalls könnte es zu Sachschäden oder sogar zu Verletzungen kommen.

- Wählen Sie einen Standort aus, der um das Gartenhaus herum genügend Platz zum Arbeiten bietet.
- Vergewissern Sie sich, bevor Sie mit dem Aufbau des Gerätehauses beginnen, dass Sie über ein gutes Baufundament verfügen.
- Befolgen Sie die in der Anleitung vorgeschriebenen Schritte genau, um einen korrekten Aufbau zu gewährleisten.
- Vergewissern Sie sich vor Beginn der Montage, ob alle Teile vorhanden sind.
- Stellen Sie sicher, dass der Fundamentrahmen flach auf dem Boden liegt.
- Das Fundament muss eben sein. Falls der Boden uneben sein sollte, nivellieren Sie ihn.



Tragen Sie während der Montage immer Sicherheitshandschuhe, lange Ärmel und Augenschutz. Einige Teile können möglicherweise scharfe Kanten aufweisen und Verletzungen verursachen!



• Versuchen Sie nicht, Ihr Gerätehaus bei windigen Wetterbedingungen zusammenzubauen, da die Gefahr besteht, dass Paneele beschädigt oder Personen verletzt werden.

• Das Gerätehaus muss auf einem festen, nivellierten und waagerechten Fundament errichtet werden. Ein Stahlbetonfundament oder große Betonplatten werden als Bodenkonstruktion empfohlen. Die Abmessungen des Fundamentes sollten mindestens 10 cm größer sein als die Abmessungen des Gerätehauses. Die Wahl und der Aufbau Ihres Fundaments sind nicht von der Garantie abgedeckt. Das Unternehmen übernimmt keine Verantwortung für die Auswahl und Qualität des Fundaments.

• Bereiten Sie für ein Stahlbetonfundament eine erste Schicht mit Steinen bzw. Kies vor. Das Fundament sollte eine Stärke von mindestens 10 cm aufweisen. Lassen Sie den

Beton mindestens 48 Stunden trocknen.

- Fundamente können auch aus Ziegeln, Steinblöcken oder Betonsockeln errichtet werden.
- Das Gerätehaus ist nicht dafür vorgesehen, direkt auf dem Rasen aufgebaut zu werden.



• **Ihr Gerätehaus muss fest am Fundament verankert sein, um Beschädigung durch starken Wind zu verhindern. Im Lieferumfang sind keine Verankerungen enthalten!**



• Bewahren Sie keine Chemikalien in Ihrem Gartenhaus auf. Feuergefährliche, scharfe oder ätzende Materialien müssen in luftdichten und entsprechend zugelassene Behältern aufbewahrt werden.



• Eine Schneeschicht von mehr als 10 cm kann gefährlich werden!



• Betreten Sie nicht das Dach! **EINSTURZGEFAHR!**

Vor dem Aufbau

- Achten Sie darauf, dass es an dem Tag, den Sie für die Montage auswählen, trocken und windstill ist.
- Entnehmen Sie die Teile aus dem Karton und sortieren Sie sie nach den Nummern. Vergewissern Sie sich, dass alle notwendigen Teile für den Aufbau vorhanden sind.
- Machen Sie sich mit der Funktionsweise aller Werkzeuge vertraut.
- Halten Sie Kinder und Haustiere vom Montageort fern.
- Wenn Sie eine Leiter verwenden, achten Sie auf deren stabilen Stand. Bitte niemals mit vollem Gewicht auf irgendein Teil des Daches oder Gerätehauses stellen.
- Stellen Sie das Drehmoment Ihres Akkuschaubers ein, um die Beschädigung der Metallteile zu vermeiden.

i

• Entfernen Sie vor der Montage die Schutzfolien.

• Benutzen Sie bei vorlackierten Oberflächen nur Schrauben mit Plastikunterlegscheiben.

• Vermeiden Sie so gut wie möglich überhängende Bäume, da herabfallende Blätter eine regelmäßige Reinigung erforderlich machen und abbrechende Äste eine Gefahrenquelle darstellen.

i

• Kleine Bäume, Sträucher oder Zäune in der Nähe können als Windschutz hilfreich sein.

Wartung und Pflege

Wir empfehlen eine Kunststoffolie oder Plastikfolie (Dampfsperre) unter der gesamten Stellfläche. Gute Belüftung mindert eventuelle Schäden an eingelagerten Gegenständen durch Feuchtigkeitseintritt vom Boden und vermindert Kondensation im Inneren. Sie können alle Verbindungen zusätzlich mit Silikon abdichten.

Für eine lange Lebensdauer sollten Sie das Gartenhaus regelmäßig reinigen. Verwenden Sie hierzu keine scharfen/aggressiven Reiniger. Bessern Sie Kratzer mit geeigneter Farbe so schnell wie möglich aus. Reinigen Sie die Stelle gründlich und tragen Sie dann die Farbe auf. Sollten Sie dies versäumen und mit dem Kratzer wurde die Beschichtung geschädigt, begünstigt dies die Entstehung von Rost. Halten Sie das Dach frei von Laub und Schnee. Viel Schnee auf dem Dach kann das Haus beschädigen. Halten Sie Türen und Laufschiene möglichst frei von Schmutz. Reinigen Sie die Laufschiene und Rollen regelmäßig und sprühen Sie diese mit Silicon-Spray ein. Bitte schließen Sie nach Verwendung immer das Tor, um Beschädigungen durch Wind zu vermeiden.

INSTRUCTIONS



ATTENTION! Read the safety and assembly instructions carefully, in order to avoid the risk of injury or damaging the product.



Important: Read these instructions carefully and thoroughly. Keep these instructions to read through at a later date. If you give the product to anyone else at some point in the future, please ensure you also pass on this manual



Only for domestic use and not for commercial use!



Keep small parts, plastic bags and other packaging out of the reach of children.

Pay attention especially when unpacking your item. Danger of suffocation!

Check the delivery for completeness. Later complaints cannot be accepted.

Check all elements and parts for damages. Despite careful control, products may be damaged in transit. In this case, do not assemble your product. Defective parts can endanger your health.



Never modify the product! Changes will void the warranty and the product may be unsafe or even dangerous.

Unpack all the parts and elements of the set and place the components on the top of the carton or other clean surface. This protects your new product.

Please also pay attention not to scratch the floor while working with tools.

Make sure that this product is fully assembled before use, as shown in the illustration

Location

Prior to starting the installation, familiarize yourself with the relevant local rules and regulations. When choosing the most suitable location for the garden shed, make sure that the ground is stable and straight and that no exposed location is chosen where the garden shed is completely free! A certain degree of protection against storms and gusts of wind must be guaranteed. Freestanding will otherwise cause damage. base. Set up the building only when the weather is fine and dry. Do not install if there are strong winds!

Instructions

Prior to starting the installation, familiarize yourself with the relevant local rules and regulations. Find a stable and level place as a base. Set up the building only when the weather is fine and dry. Do not install if there are strong winds!

If possible, set up the garden house together with 3 or more people. Otherwise, there could be material damage or even injuries.

- Choose a location that has enough space around the garden house for working.
- Before you start building the garden shed, make sure that you have a good foundation.
- Carefully follow the steps in the instructions to ensure correct installation.
- Before starting the installation, make sure that all parts are present.
- Make sure the foundation frame is flat on the floor.
- The foundation must be level. If the floor is uneven, level it.



- Always wear safety gloves, long sleeves and eye protection during installation.

Some parts may have sharp edges and may cause injury!



- Do not attempt to assemble it in windy weather conditions as there is a risk that panels may be damaged or people injured.

• The shed must be built on a solid, level and horizontal foundation. A reinforced concrete foundation or large concrete slabs are recommended as a floor construction. The dimensions of the foundation should be at least 10 cm larger than the dimensions of the garden house. The choice and construction of your foundation are not covered by the warranty. The company assumes no responsibility for the selection and quality of the foundation.

• Prepare a first layer of stones or gravel for a reinforced concrete foundation. The foundation should be at least 10 cm thick. Allow the concrete to dry for at least 48 hours.

• The foundations can also be made of bricks, stone blocks or concrete pedestals.

• The garden shed is not intended to be built directly on the lawn.



• **Your shed must be firmly anchored to the foundation to prevent damage from strong winds. No anchors are included in the equipment supplied!**



• Do not store any chemicals in your garden shed. Flammable, sharp or corrosive materials must be stored in airtight and appropriately approved containers.



• A snow layer of more than 10 cm can be dangerous!



• Do not enter into the roof! DANGER OF COLLAPSE!

Before assembly

- Make sure that the day you select for installation is dry and free of wind.
- Remove the parts from the box and sort them by number. Make sure that all necessary parts are available for assembly.
- (i) • Familiarize yourself on how to use all the tools.
 - Keep children and pets away from the assembly site.
- (i) • When using a ladder, make sure it is stable. Never place a heavy load on any part of the roof or shed.
 - Adjust the torque of your cordless screwdriver to avoid damaging the metal parts.
 - Remove the protective foils before mounting.
 - On pre-painted surfaces, only use screws with plastic washers.
 - Avoid overhanging trees as much as possible, as falling leaves require regular cleaning and breaking branches are a source of danger.
 - Small trees, shrubs or nearby fences can help protect against the wind.

Maintenance and care

We recommend a plastic film or a plastic foil (vapor barrier) under the entire floor space. Good ventilation reduces possible damage to stored objects due to moisture ingress from the floor and reduces condensation inside. You can also seal all connections with silicone.

For a long service life, you should regularly clean the garden house. Do not use sharp/aggressive cleaners to do this. Repair scratches with a suitable paint as quickly as possible. Clean the area thoroughly and then apply the paint. If you fail to do this and the scratch damages the coating, there is a risk for rust formation. Keep the roof free of leaves and snow. A lot of snow on the roof can damage the house. Keep doors and rails as free from dirt as possible. Clean the running rails and rollers regularly and spray them with silicone spray. Please always close the door after use to avoid damage by wind.

Important! If necessary, do not tighten the screws completely during assembly in order to be able to easily readjust them in the course of assembly.

ORIENTATION



ATTENTION! Respectez les consignes de sécurité et de montage pour éviter tout risque de blessure ou d'endommagement du produit.



Important: Lisez ces instructions avec attention dans leur totalité. Gardez ces instructions afin de pouvoir les relire dans le futur. Si vous donnez ce produit à une autre personne, veuillez également faire passer cette notice.



**Uniquement pour usage domestique
et en aucun cas à des fins commerciales!**



Gardez les petites pièces hors de portée des enfants. Faites particulièrement attention au moment de déballer le produit. Gardez les sacs plastiques et autres emballages hors de portée des enfants. Risque de suffocation !

Assurez-vous que la livraison a été faite dans son intégralité. Des réclamations ultérieures ne pourront pas être prises en compte.

Vérifier que tous les éléments et toutes les pièces n'ont subis aucun dommage. Malgré le soin apporté, il est possible que même le meilleur des produits ait été endommagé pendant le transport. Dans ce cas, ne montez pas le produit. Des pièces endommagées peuvent mettre votre santé en danger.



Ne modifiez jamais le produit ! Les modifications annulent la garantie et le produit pourrait être peu sûr, voir même dangereux.

Déballez toutes les pièces et éléments fournis et placez-les sur le dessus du carton ou toute autre surface plate et propre. Cela protégera votre nouvel article.

Veillez à ne pas rayer le sol durant la manutention avec les outils.

Il est essentiel que l'assemblage de l'article soit complet conformément aux illustrations fournies avant que celui-ci ne puisse être utilisé.

Exposition

Avant de commencer l'installation, familiarisez-vous avec les réglementations et ordonnances locales. Lorsque vous choisissez l'emplacement le plus approprié pour le hangar, assurez-vous que le sol est stable et droit et qu'aucun emplacement exposé n'est choisi où le hangar est complètement libre ! Une certaine protection contre les tempêtes et les intempéries. Les rafales doivent être garanties. Dans le cas contraire, la pose en pose libre causera des dommages.

Consignes

Avant de commencer le montage, se familiariser avec les réglementations et directives locales. Trouver un support ferme et plat. Installer la maison uniquement par temps sec et beau. Ne pas installer en cas de vent fort !

Si possible, installer la maison de jardin avec 3 personnes ou plus. Sinon, des dommages matériels, voire des blessures, pourraient survenir.

- Choisir un emplacement offrant suffisamment d'espace pour travailler autour de l'abri de jardin.
- S'assurer d'avoir de bonnes fondations avant de commencer la construction de cet abri de jardin.
- Suivre les étapes décrites dans le manuel pour garantir une installation correcte.
- S'assurer que toutes les pièces sont présentes avant de commencer l'assemblage.
- Veiller à ce que le cadre des fondations soit à plat sur le sol.
- La surface des fondations doit être plane. Si le sol est inégal, le niveler.



Toujours porter des gants de protection, des manches longues et des lunettes de protection lors de l'assemblage. Certaines pièces peuvent avoir des bords tranchants et causer des blessures !



Ne pas essayer d'assembler votre équipement en cas de vent, vous risqueriez d'endommager les panneaux ou de blesser quelqu'un.

• L'abri de jardin doit être érigé sur des fondations solides, nivelées et horizontales. Des fondations en béton armé ou de grandes dalles en béton sont recommandées. Les dimensions des fondations doivent être au moins 10 cm plus grandes que celles de l'abri de jardin. Le choix et la construction de vos fondations ne sont pas couverts par la garantie. Nous n'assumons aucune responsabilité quant au choix et à la qualité des fondations.

- Pour des fondations en béton armé, préparer une première couche de pierre ou de gravier. Les fondations doivent avoir une épaisseur d'au moins 10 cm. Laisser le béton sécher pendant au moins 48 heures.
- Les fondations peuvent également être construites en briques, en blocs de pierre ou



• Votre abri de jardin doit être solidement ancré aux fondations pour éviter les dommages causés par les vents violents. Le contenu de la livraison n'inclut pas les ancrés !



• Ne pas stocker de produits chimiques dans votre abri de jardin. Les matériaux inflammables, tranchants ou corrosifs doivent être entreposés dans des contenants étanches à l'air et appropriés.



• Une épaisseur de neige de plus de 10 cm sur le toit peut être dangereuse !



• Ne pas marcher sur le toit ! RISQUE D'EFFONDREMENT !

Avant la construction

- Veiller à ce que le jour choisi pour l'installation, l'air soit sec et qu'il n'y ait pas de vent.
- Retirer les pièces du carton et les trier par numéros. S'assurer que toutes les pièces nécessaires sont disponibles pour l'assemblage.
- Se familiariser avec le fonctionnement de tous les outils.
- Tenir les enfants et les animaux domestiques hors de portée.
- Si vous utilisez une échelle, assurez-vous qu'elle est stable. Ne jamais placer tout votre poids sur une partie du toit ou de l'abri de jardin.
- Ajuster le couple de serrage de votre tournevis sans fil pour éviter d'endommager les pièces métalliques.
- Enlever les films de protection avant le montage.
- (i) • Pour les surfaces pré-peintes, utiliser uniquement des vis avec rondelles en plastique.
 - Éviter autant que possible de monter votre abri sous un/des arbre(s), car les feuilles qui tombent nécessitent un nettoyage régulier de la toiture et la rupture des branches est une source de danger.
- (i) • Les petits arbres, arbustes ou clôtures à proximité peuvent être utiles comme brise-vent.

Maintenance et entretien

Nous recommandons de placer un film plastique (pare-vapeur) sous toute la surface au sol. Une bonne ventilation réduit les dommages éventuels aux objets stockés dus à l'infiltration d'humidité par le sol et réduit la condensation à l'intérieur. Vous pouvez également sceller tous les joints avec du silicone.

Pour une longue durée de vie, nettoyer régulièrement l'abri de jardin. Ne pas utiliser de produits nettoyants puissants / agressifs. Corriger les rayures avec la couleur appropriée aussi vite que possible. Nettoyer soigneusement la zone, puis appliquer la peinture. Si vous ne le faites pas et que les rayures ont endommagé le revêtement, de la rouille se développera. Garder le toit exempt de feuilles et de neige. Beaucoup de neige sur le toit peut endommager l'abri. Garder les portes et les rails aussi propres que possible. Nettoyer les rails et les rouleaux régulièrement et les pulvériser avec du silicone. Toujours fermer la porte après utilisation pour éviter les dommages dus au vent.

ISTRUZIONI



ATTENZIONE! Osservare le istruzioni di sicurezza e di montaggio per evitare il rischio di lesioni o danni al prodotto.



Importante: Leggere le istruzioni completamente e in maniera accurata. Conservare questo manuale per consulti futuri. Se un giorno venderai il prodotto, assicurati di consegnare anche questo manuale.



Solo per uso domestico e non adatto ad un utilizzo commerciale! .



Tenere le parti più piccole al di fuori dalla portata dei bambini. Inoltre, soprattutto all'apertura del pacco, assicurati di tenere buste di plastica e materiali per l'imballaggio fuori dalla portata dei bambini! Pericolo di soffocamento!

Controllare che la consegna sia completa. Reclami successivi alla consegna non possono essere accettati.

Controllare tutti gli elementi e le parti non presentino danni. Nonostante controlli accurati, può accadere che anche i migliori prodotti vengano danneggiati lungo il percorso durante la consegna. In tal caso, non testare e mettere in funzione il prodotto. Le parti difettose possono causare pericoli e danni alla salute.



Non apportare mai modifiche al prodotto! Le modifiche invalideranno la garanzia e potrebbero rendere il prodotto non sicuro o, nel peggiore dei casi pericoloso.

Disimballare tutte le parti e gli elementi del kit e posizionare i componenti sopra il cartone o altra superficie pulita. Questo protegge il tuo nuovo prodotto.

Inoltre, fare attenzione a non graffiare il pavimento quando si lavora con gli strumenti.

Assicurarsi che questo prodotto sia completamente assemblato prima dell'uso, come mostrato nell'illustrazione.

Posizione

Prima di iniziare l'installazione, familiarizzate con le norme e le ordinanze locali. Quando si sceglie il luogo più adatto per il capannone, assicurarsi che il terreno sia stabile e dritto e che non si scelga un luogo esposto dove il capannone sia completamente libero! Una certa protezione contro le tempeste e i temporali. Le raffiche devono essere garantite. In caso contrario, l'autoportante causerà danni.

Istruzioni

Prima di iniziare a costruire, familiarizzare con i regolamenti e le normative locali. Trovare una base solida e piana. Installare la casa solo in caso di bel tempo secco. Non installarla con vento forte!

Se possibile, allestire la casetta da giardino insieme a 3 o più persone. In caso contrario, potrebbero verificarsi danni ai materiali o persino lesioni.

- Scegliere una posizione che offra spazio sufficiente per aggirare la casetta estiva.
- Assicurarsi di disporre di una buona base di costruzione prima di iniziare la costruzione del capanno degli attrezzi.
- Seguire i passaggi prescritti nel manuale per garantire la corretta installazione.
- Accertarsi che tutte le parti siano presenti prima di iniziare il montaggio.
- Accertarsi che il telaio delle fondamenta sia piatto sul terreno.
- Le fondamenta devono essere a livello. Se il terreno è irregolare, livellarlo.



Indossare sempre guanti di sicurezza, maniche lunghe e protezione per gli occhi durante il montaggio. Alcune parti possono presentare spigoli vivi e provocare lesioni!



- Non tentare di assemblare il capanno degli attrezzi in condizioni meteorologiche ventose poiché esiste il rischio di danni ai pannelli o lesioni personali.
- La tettoia deve essere eretta su una base solida, livellata ed orizzontale. Si consigliano una fondazione in cemento armato o grandi lastre di cemento come costruzione del pavimento. Le dimensioni della fondazione dovrebbero essere almeno 10 cm più grandi delle dimensioni del capanno degli attrezzi. La scelta e la struttura delle fondamenta non sono coperte da garanzia. La società non si assume alcuna responsabilità per la selezione e la qualità delle fondamenta.
- Per delle fondamenta in cemento armato, preparare un primo strato di pietra o ghiaia. Le fondamenta dovrebbero avere uno spessore di almeno 10 cm. Lasciare asciugare il calcestruzzo per almeno 48 ore.
- Le fondamenta possono anche essere costruite con mattoni, blocchi di pietra o basi di cemento.
- La tettoia non è progettata per essere installata direttamente sul prato.
- Il capanno degli attrezzi deve essere saldamente ancorato alle fondamenta per evitare danni causati da forti venti. La fornitura non comprende le ancore!

- Non conservare prodotti chimici nella casetta da giardino. I materiali infiammabili, aggressivi o corrosivi devono essere conservati in contenitori ermetici ed adeguatamente approvati.
- Uno strato di neve superiore a 10 cm può essere pericoloso!
- Non calpestare il tetto! PERICOLO DI COLLASSO!



• **Il capanno degli attrezzi deve essere saldamente ancorato alle fondamenta per evitare danni causati da forti venti. La fornitura non comprende le ancore!**



• Non conservare prodotti chimici nella casetta da giardino. I materiali infiammabili, aggressivi o corrosivi devono essere conservati in contenitori ermetici ed adeguatamente approvati.



• Uno strato di neve superiore a 10 cm può essere pericoloso!



• Non calpestare il tetto! PERICOLO DI COLLASSO!

Prima della costruzione

- Assicurarsi che il giorno in cui si sceglie di effettuare l'assemblaggio sia asciutto e senza vento.
- Rimuovere i pezzi dalla scatola ed ordinarli per numero. Assicurarsi che tutte le parti necessarie siano disponibili per la carrozzeria.
- Acquisire familiarità con il funzionamento di tutti gli strumenti.
- Tenere bambini e animali domestici lontano dal luogo di installazione.
- (i) • Quando si utilizza una scala, assicurarsi che sia stabile. Non collocare mai il peso totale su nessuna parte del tetto o dell'attrezzatura.
- Regolare la coppia del cacciavite a batteria per evitare di danneggiare le parti metalliche.
- (i) • Rimuovere le pellicole protettive prima del montaggio.
- Per superfici preverniciiate, utilizzare solo viti con rondelle di plastica.
- Evitare il più possibile la sporgenza di alberi, poiché le foglie che cadono richiedono una pulizia regolare e la rottura dei rami è fonte di pericolo.
- Piccoli alberi, arbusti o recinti nelle vicinanze possono essere utili come frangivento.

Manutenzione e cura

Si consiglia un film o una pellicola di plastica (barriera al vapore) sotto l'intero ingombro. Una buona ventilazione riduce i possibili danni agli oggetti immagazzinati a causa dell'ingresso di umidità dal pavimento e riduce la condensa all'interno. È inoltre possibile sigillare tutte le connessioni con silicone.

Per assicurarne una lunga vita si dovrebbe pulire la casa da giardino regolarmente. Non utilizzare detergenti pungenti / aggressivi. Correggere i graffi con il colore adatto il più velocemente possibile. Pulire accuratamente l'area e quindi applicare la vernice. Se si salta questa procedura ed i graffi danneggiano il rivestimento, ciò favorirà la formazione di ruggine. Mantenere il tetto libero da foglie e neve. Molta neve sul tetto può danneggiare la casa. Mantenere le porte e le guide libere il più possibile dallo sporco. Pulire regolarmente le guide ed i rulli e spruzzarli con spray al silicone. Si prega di chiudere sempre il cancello dopo l'uso per evitare danni dovuti al vento.

INSTRUCCIONES



¡ATENCIÓN! Siga las instrucciones de seguridad y de montaje para evitar el riesgo de lesiones o daños al producto.



Importante: Lea las instrucciones detenidamente y cuidadosamente. Conserve este manual para futuras consultas. Si vende el producto algún día, asegúrese de entregar también este manual.



¡Solo para uso doméstico y no apto para uso comercial!



Mantener las partes pequeñas lejos de los niños. Además, especialmente al sacar el producto del embalaje, ¡asegúrese de mantener las bolsas de plástico y otros envases fuera del alcance de los niños! ¡Peligro de asfixia!

Compruebe la integridad del producto en el momento de la entrega. No se aceptarán reclamaciones posteriores.

Compruebe que todos los elementos y partes del producto no estén dañados. A pesar de los controles cuidadosos, puede ocurrir que incluso los mejores productos se dañen durante el transporte. En este caso, no monte el producto. Las partes defectuosas pueden causar peligros y daños a la salud.



¡Nunca haga cambios en el producto! Las modificaciones invalidan la garantía y podrían hacer que el producto sea inseguro o, en el peor de los casos, incluso peligroso. Desembale todas las piezas y elementos del kit y coloque los componentes encima de cartón u otra superficie limpia. Esto protege su nuevo producto.

Además, tenga cuidado de no rayar el suelo cuando trabaje con herramientas.

Asegúrese de que este producto esté completamente ensamblado antes de usarlo, como se muestra en la ilustración.

Sitio

Antes de comenzar la instalación, familiarícese con las regulaciones y ordenanzas locales. Al elegir el lugar más adecuado para el cobertizo, asegúrese de que el suelo sea estable y recto y que no se elija un lugar expuesto donde el cobertizo esté completamente libre! Una cierta protección contra las tormentas y el clima tormentoso. Las ráfagas deben estar garantizadas. De lo contrario, la independencia causará daños.

AVISO

Antes de comenzar con el montaje, tome en cuenta las regulaciones locales. Encuentre un lugar estable y fijo como base. Instale la casa de jardín en un lugar seco y agradable. ¡No la instale donde haya corrientes de viento fuerte!

Le recomendamos instalar la casa de jardín con ayuda de 3 o más personas, con el fin de reducir accidentes o daños materiales.

- Elija un lugar amplio y con suficiente espacio para realizar el montaje.
- Asegúrese de haber colocado correctamente las bases antes de comenzar la construcción del cobertizo.
- Siga los pasos prescritos en el manual para garantizar una instalación correcta.
- Asegúrese de tener todas las piezas antes de comenzar el montaje.
- Asegúrese de que el marco de la base esté colocado de forma plana sobre el suelo.
- La base debe estar nivelada. Si el suelo es irregular, deberá nivelarlo.



Siempre use guantes de seguridad, mangas largas y protección para los ojos durante el montaje. ¡Algunas partes pueden tener bordes afilados y causar lesiones!



• No realice el montaje del cobertizo en condiciones de clima ventoso ya que existe el riesgo de daños a los paneles o lesiones personales.

• El cobertizo debe erigirse sobre una superficie sólida, nivelada y horizontal. Le recomendamos utilizar una base de hormigón o hacer grandes losas de hormigón como construcción del piso. Las dimensiones de la base deben ser al menos 10 cm más grandes que las dimensiones del cobertizo. La elección y la estructura de su base no están cubiertas por la garantía. La empresa no se hace responsable por la selección y calidad de la cimentación.

• Para una base de hormigón armado, prepare una primera capa de piedra o grava. La base debe tener un grosor de al menos 10 cm. Permita que el concreto se seque durante al menos 48 horas.

• Los cimientos también pueden construirse a partir de ladrillos, bloques de piedra o bases de concreto.

• El cobertizo no está diseñado para instalarse directamente en el césped.



• El cobertizo debe estar firmemente cimentado a la base para evitar daños causados por vientos fuertes. ¡El paquete no incluye el anclaje!



• No almacene productos químicos en el cobertizo de jardín. Los materiales inflamables, corrosivos o corrosivos deben almacenarse correctamente en recipientes herméticos.



• Evite colocar el cobertizo en un lugar donde en invierno caiga mucha nieve. ¡Una capa de nieve de más de 10 cm puede ser peligrosa!



• ¡No intente subirse al techo! ¡PUEDE COLAPSARLO!

Consideraciones antes de iniciar la construcción











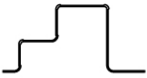

- Asegúrese de realizar la construcción en un día sin viento y en un lugar seco.
- Retire las piezas de la caja y ordénelas por números. Asegúrese de tener todas las piezas necesarias.
- Familiarícese con el funcionamiento de todas las herramientas.
- Mantenga a los niños y las mascotas alejados del sitio de instalación.
- Cuando use una escalera, asegúrese de que sea estable. Nunca la coloque sobre ninguna parte del techo o del cobertizo a instalar.
- Ajuste las velocidades del taladro para evitar dañar las partes metálicas.
- Retire las películas protectoras antes de montar.
- ① • En las superficies pre-pintadas solo utilice tornillos con arandelas de plástico.
- Evite colgar cerca de grandes árboles, ya que las hojas que caen requerirán una limpieza regular, además de que las ramas pueden causar daños.
- ① • Sin embargo, los pequeños árboles, arbustos o cercas pueden ser útiles como cortavientos.

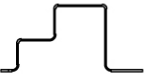











Mantenimiento y cuidado



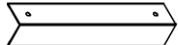
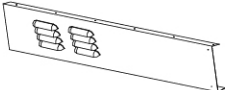
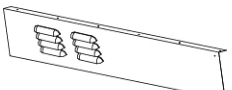

Le recomendamos colocar una película plástica (como barrera de vapor) debajo de toda la superficie. Mantenga una buena ventilación para reducir la condensación en el interior, lo cual podría dañar los objetos almacenados causados por la entrada de humedad del piso. También puede sellar todas las uniones con silicona.

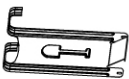





Para una larga vida, debe limpiar la casa del jardín regularmente. No utilice productos de limpieza abrasivos o agresivos.

Arregle los arañazos con el color adecuado. Limpie el área correctamente y luego aplique la pintura. Si no hace esto, los arañazos pueden dañar el revestimiento y causará la formación de óxido. Mantenga el techo libre de hojas y nieve. El exceso de nieve en el techo puede dañar la casa. Mantenga las puertas y rieles lo más limpios posible. Limpie los rieles y los rodillos regularmente y rocíelos con spray de silicona. Siempre cierre la puerta después de su uso para evitar daños por el viento.

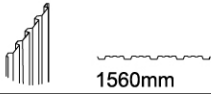
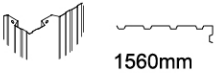
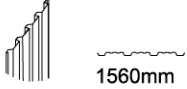
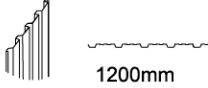
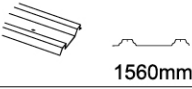

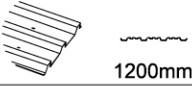

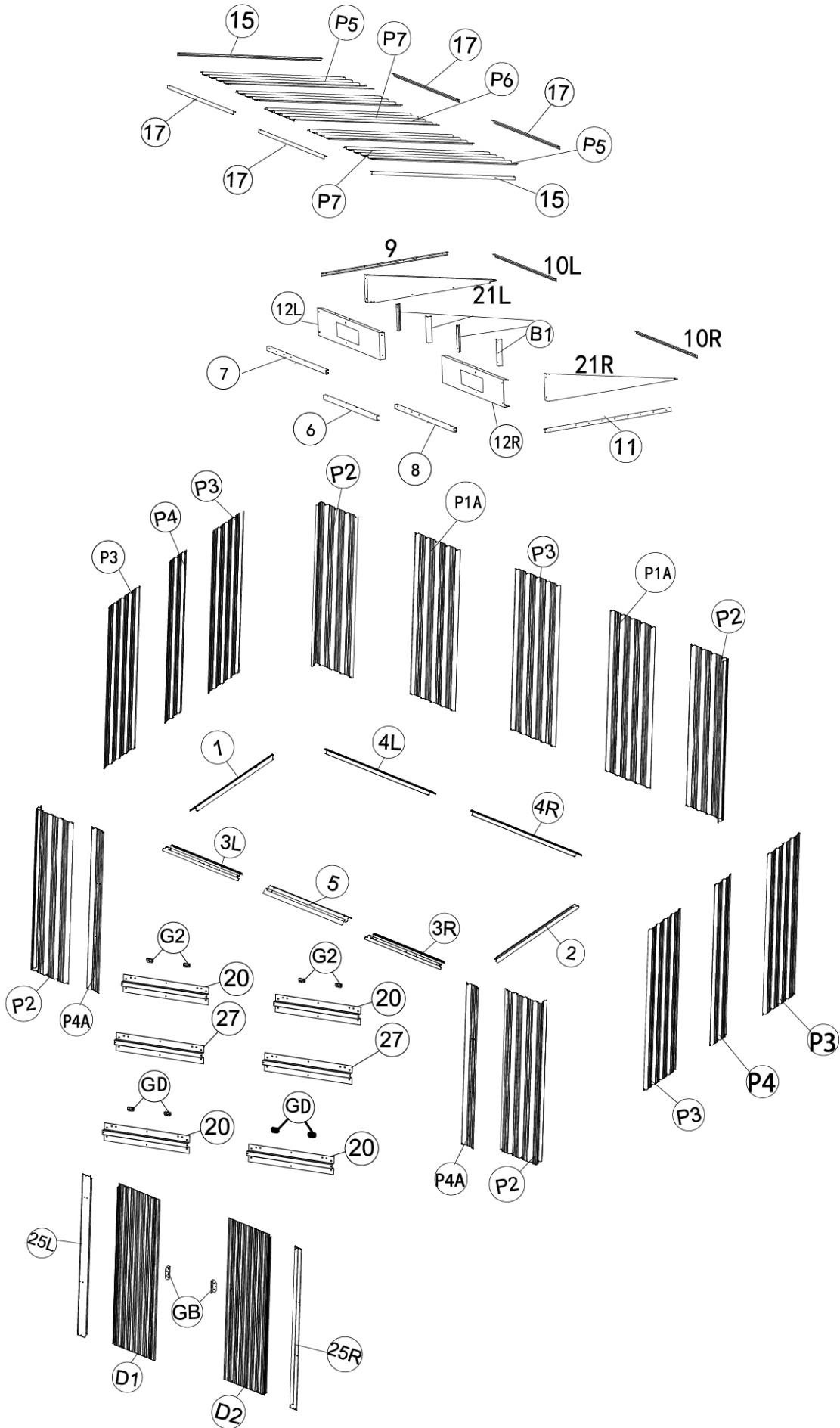

NO.	PART	Qty.	IN KARTON
1	 1070mm	1	2
2	 1070mm	1	2
3L	 620mm	1	2
3R	 620mm	1	2
4L	 955mm	1	2
4R	 955mm	1	2
5	 755mm	1	2
6	 884mm	1	2
7	 895mm	1	2
8	 895mm	1	2
9	 1045mm	1	2
10L	 910mm	1	2
10R	 910mm	1	2
11	 1045mm	1	2

NO.	PART	Qty.	IN KARTON
15	 1200mm	2	2
17	 982mm	4	2
20	 498mm	4	2
21L	 1121mm	1	2
21R	 1121mm	1	2
25L	 1560mm	1	1
25R	 1560mm	1	1
B1	 200mm	4	2
12L	 968mm	1	2
12R	 968mm	1	2
W1	 938mm	2	2
W2	 938mm	2	2
W3	 624mm	3	2
GJ		2	2
27	 498mm	2	1

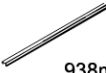

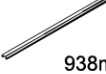
NO.	PART	Qty.	IN KARTON
G2		4	2
GD		4	2
GB		2	2
GC		4	2
GF		2	2
F1		166	2
F2		72	2
F3		8	2
S1		108	2
S2		204	2

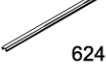
NO.	PART	Qty.	IN KARTON
P1A	 1560mm	2	2
P2	 1560mm	4	1
P3	 1560mm	5	1
P6	 1200mm	1	2
P4	 1560mm	2	2
P5	 1200mm	2	2
P7	 1200mm	2	2
P4A	 1560mm	2	2
D1	 1550X645mm	1	1
D2	 1550X645mm	1	1



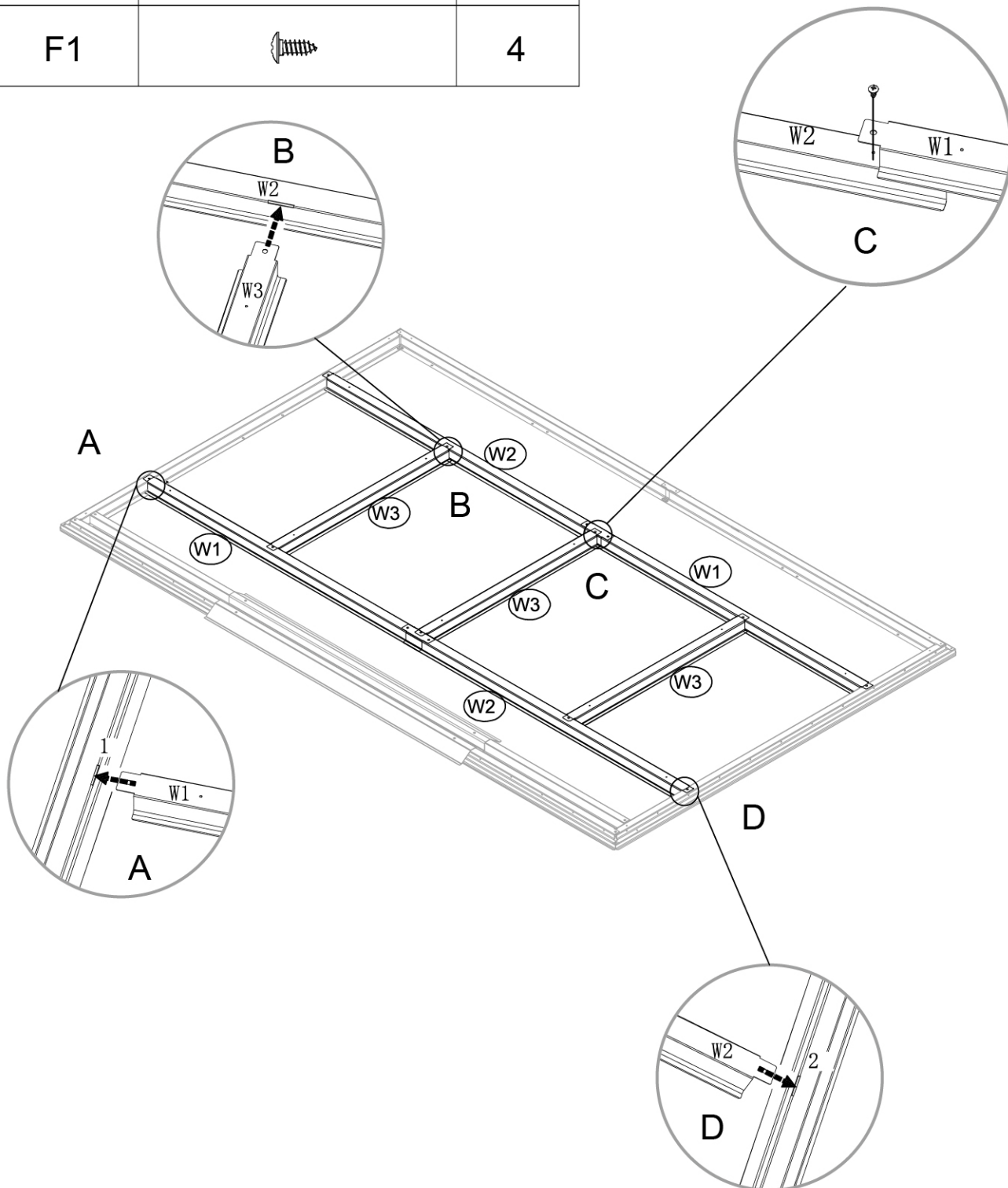

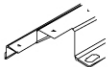
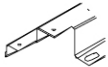
NO.	PART	Qty.
W1	  938mm	2
W2	  938mm	2
W3	  624mm	3
F1		4



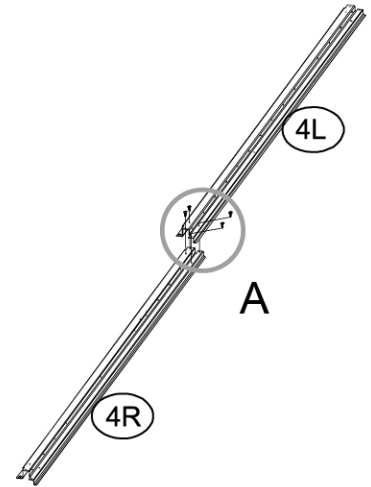
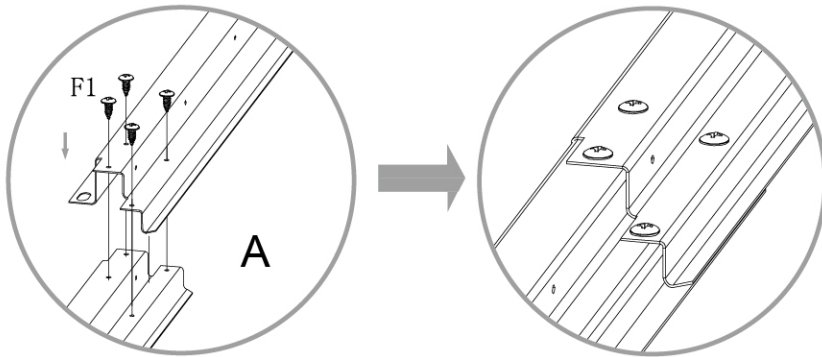

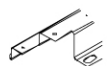
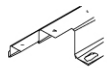
NO.	PART	Qty.
4L		1
4R		1
F1		4



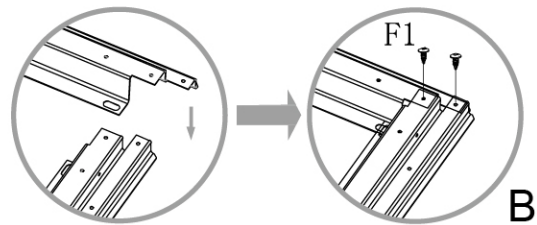
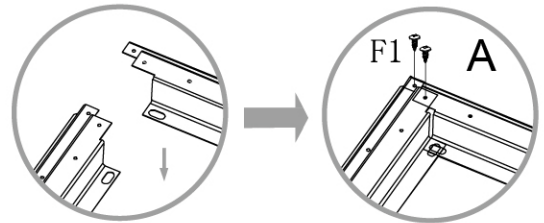
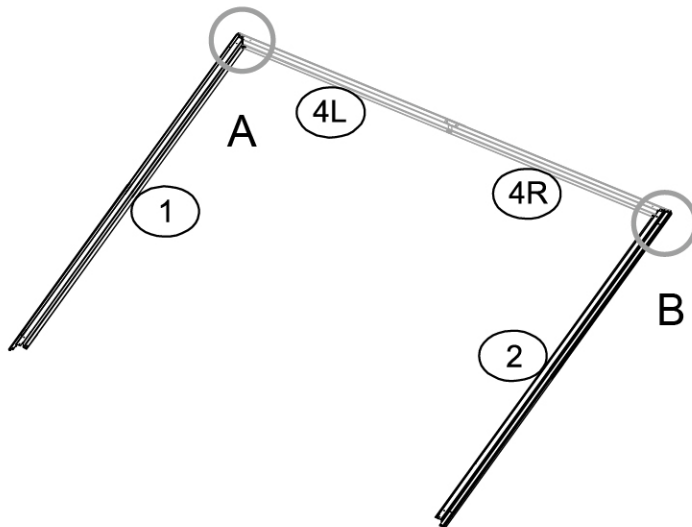

NO.	PART	Qty.
1		1
2		1
F1		4



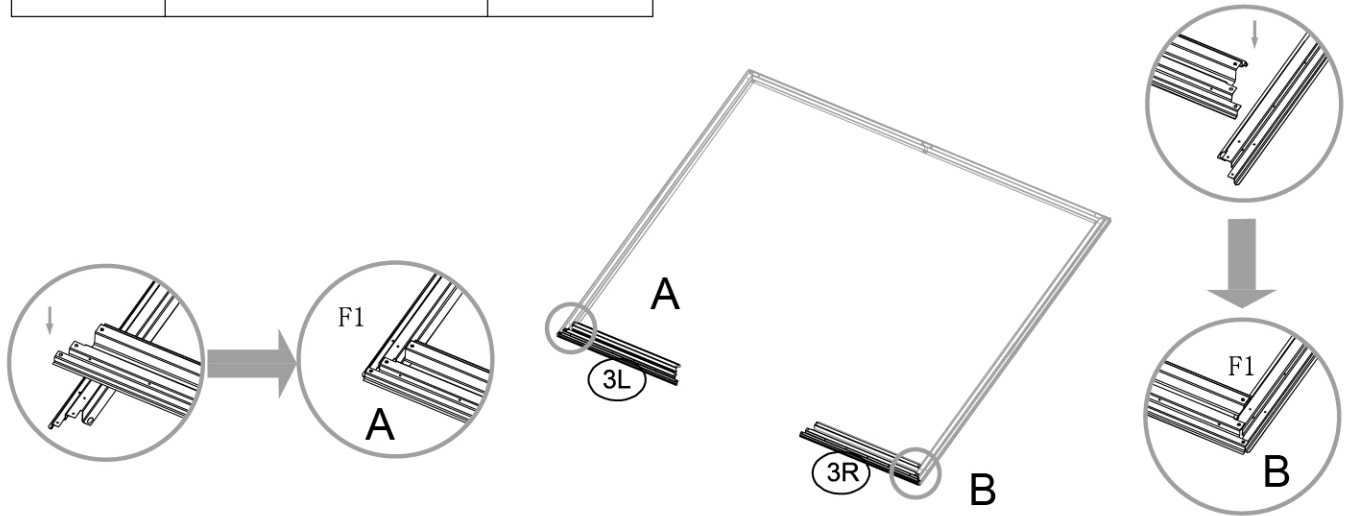

NO.	PART	Qty.
3L		1
3R		1
F1		4



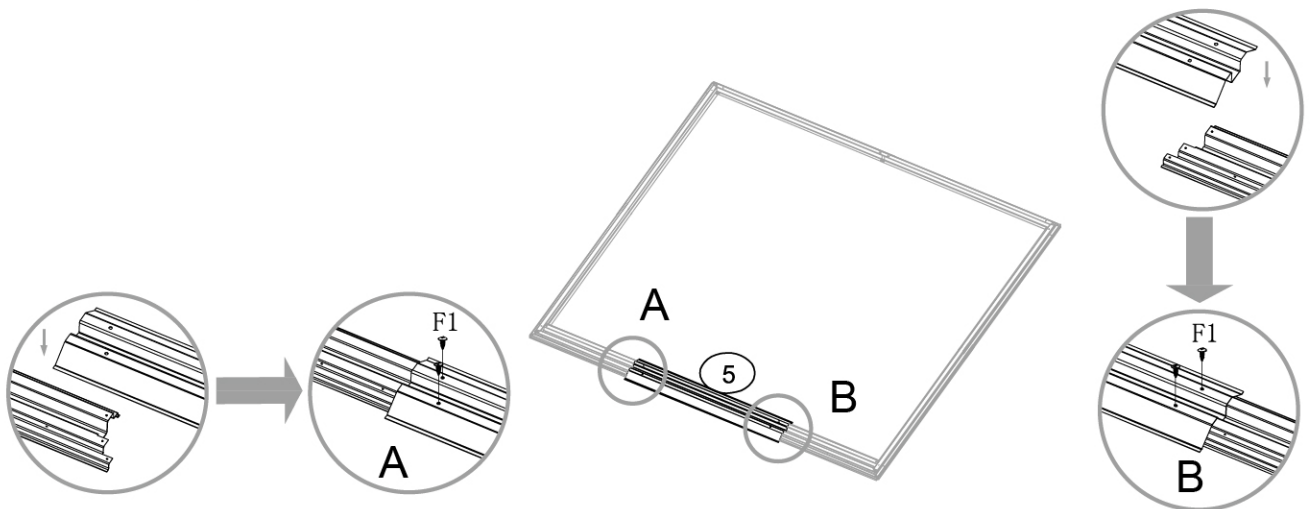



NO.	PART	Qty.
5		1
F1		4

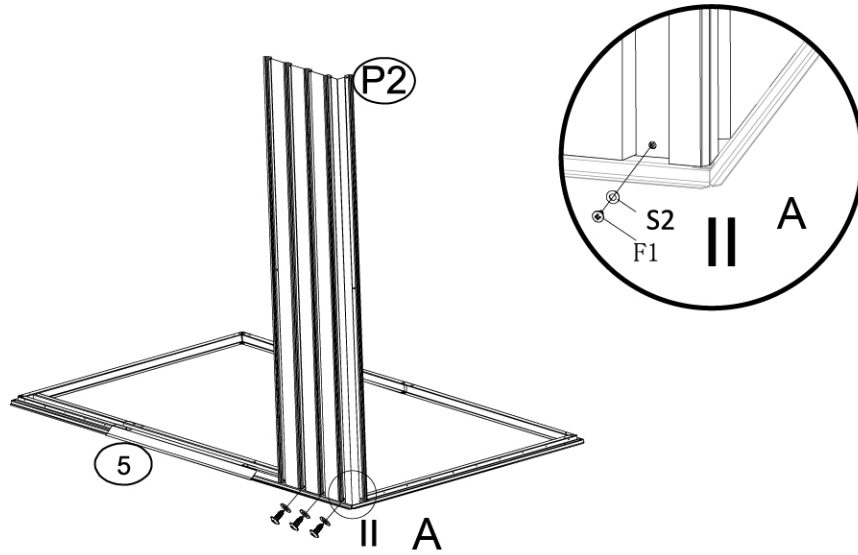



NO.	PART	Qty.
P2		1
F1		3
S2		3



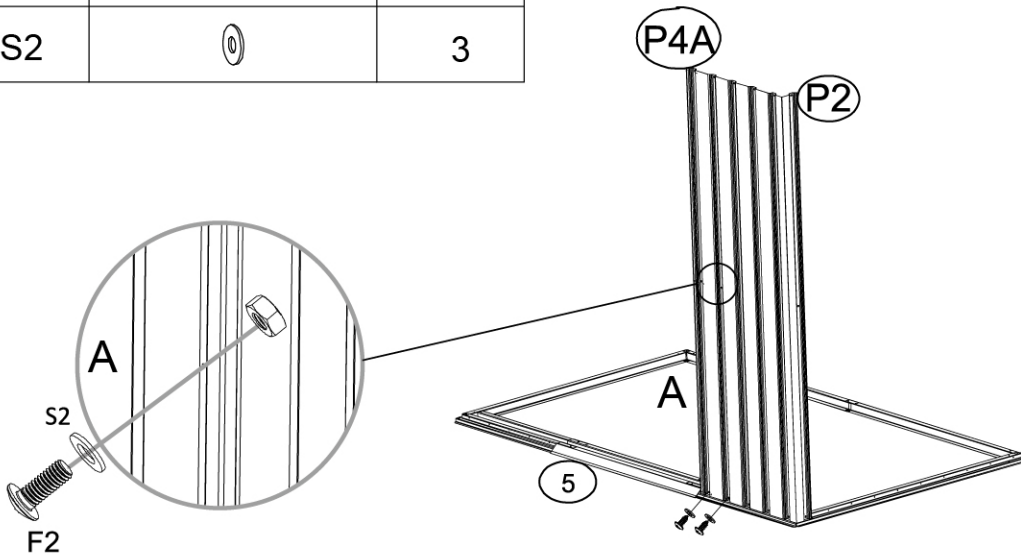



NO.	PART	Qty.
P4A		1
F1		2
F2		1
S2		3

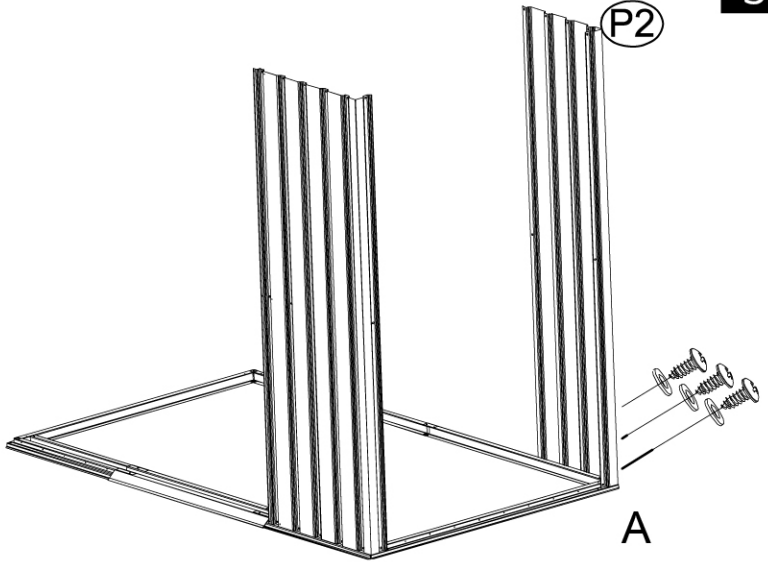
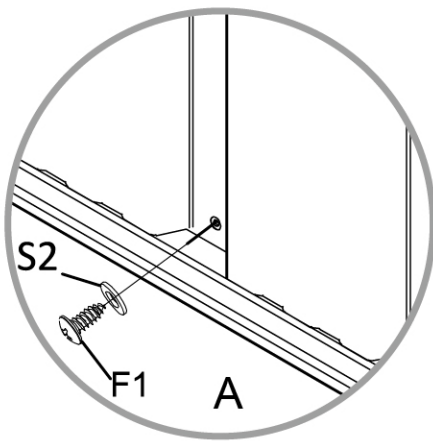

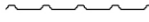

NO.	PART	Qty.
P2		1
F1		3
S2		3



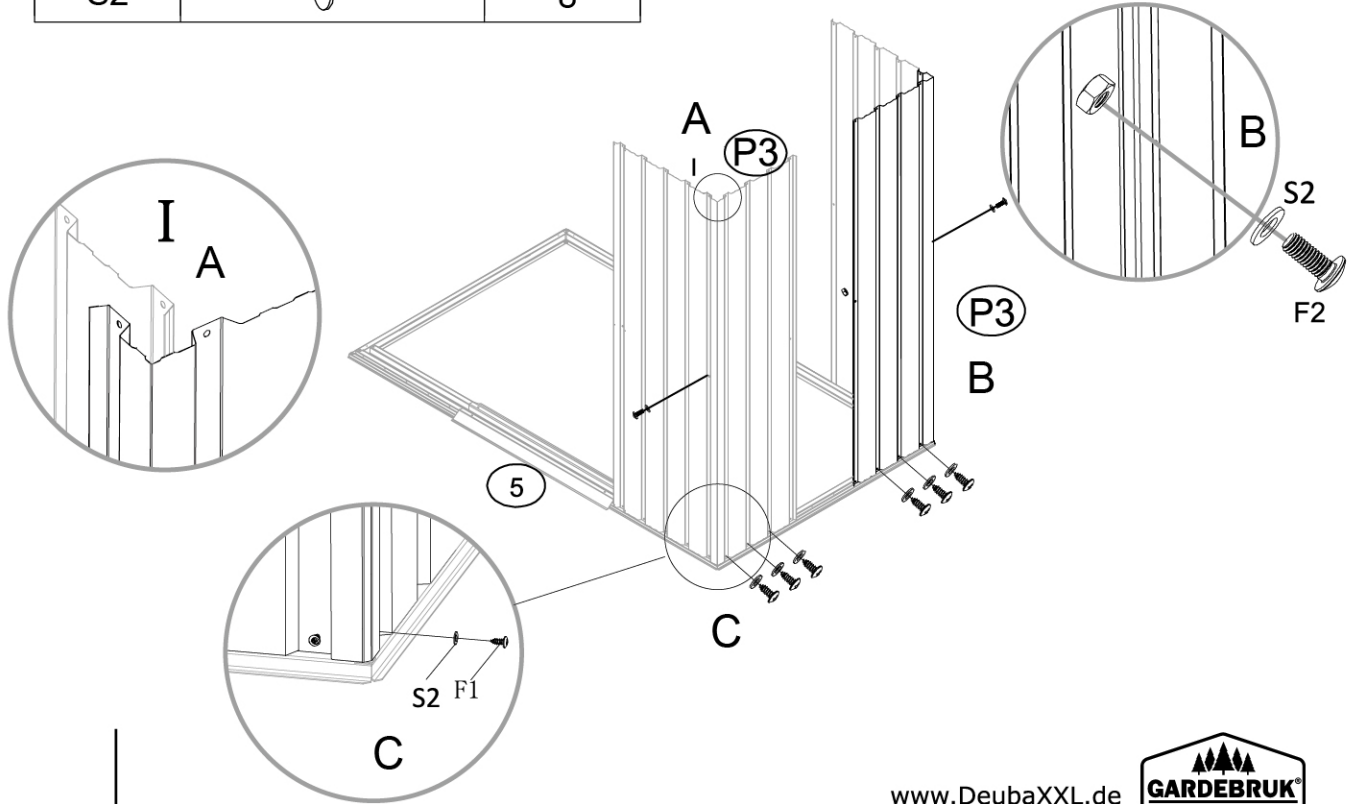



NO.	PART	Qty.
P3		2
F1		6
F2		2
S2		8

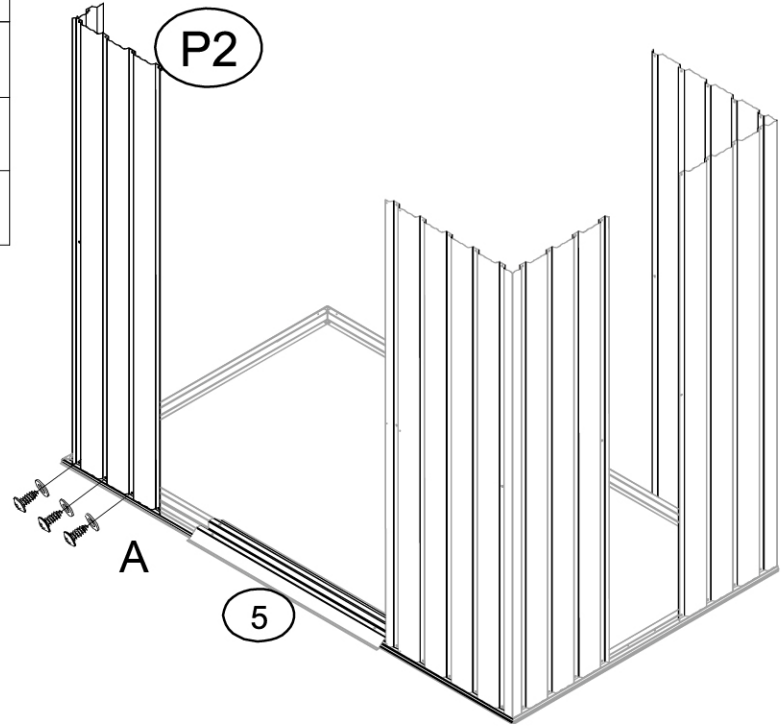
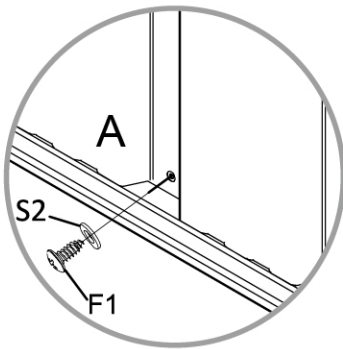

NO.	PART	Qty.
P2		1
F1		3
S2		3



NO.	PART	Qty.
P4A		1
F1		2
F2		1
S2		3

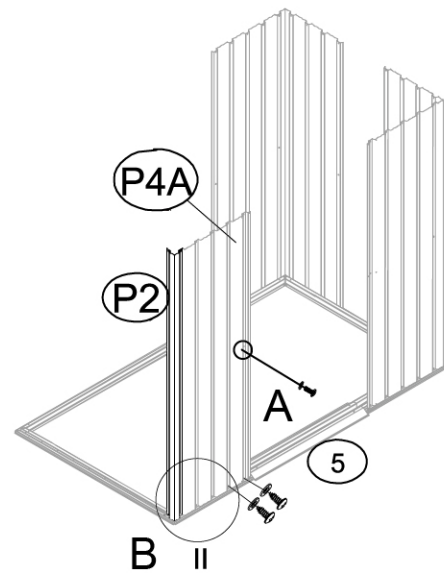
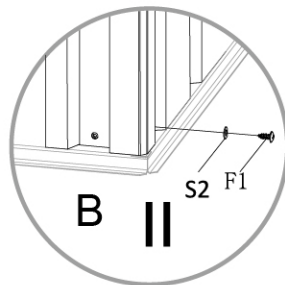
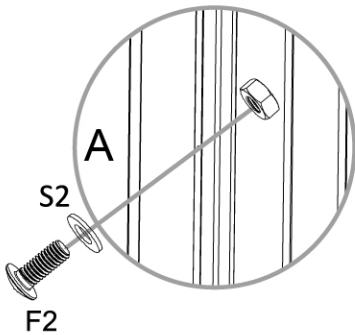

NO.	PART	Qty.
P3		1
F1		3
F2		1
S2		4

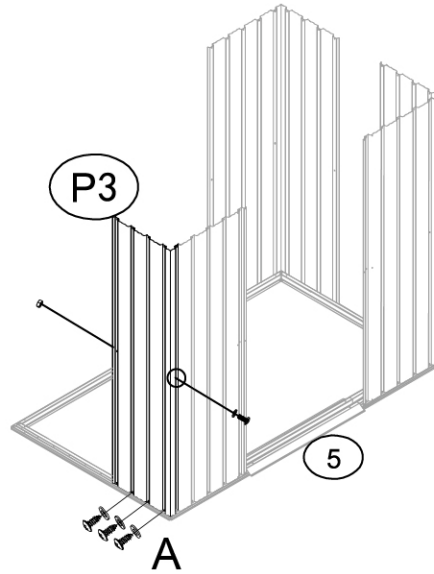
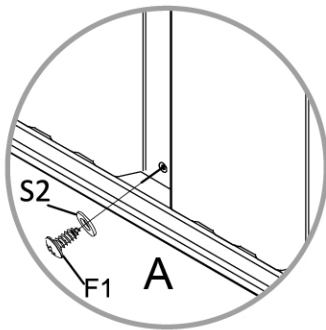

NO.	PART	Qty.
P2		1
P3		1
F1		6
F2		1
S2		7

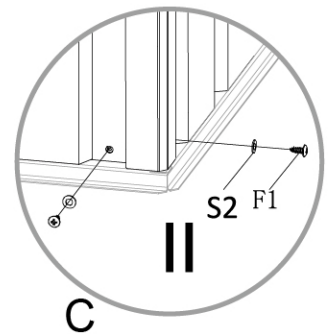
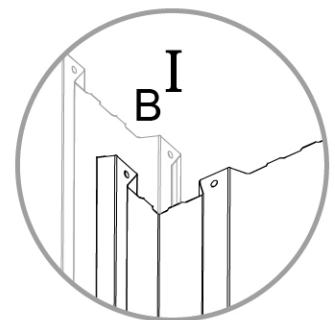
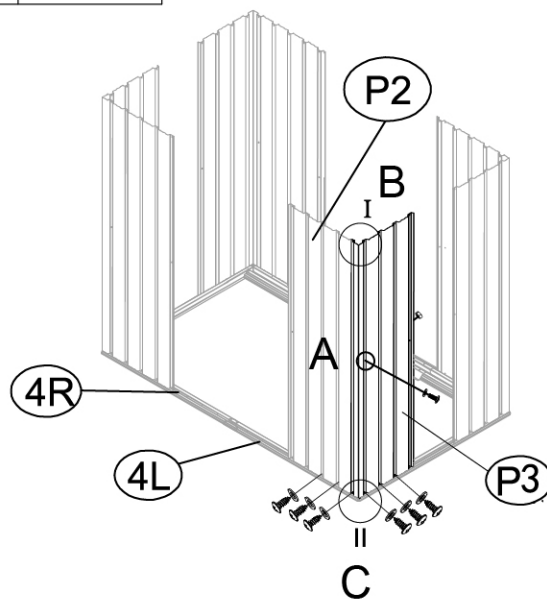
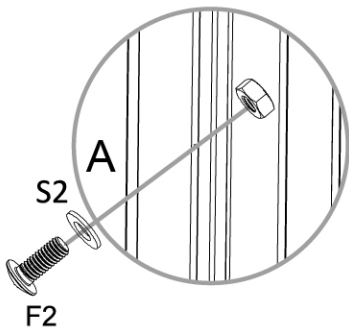

NO.	PART	Qty.
10L		1
10R		1
F1		8
S2		8

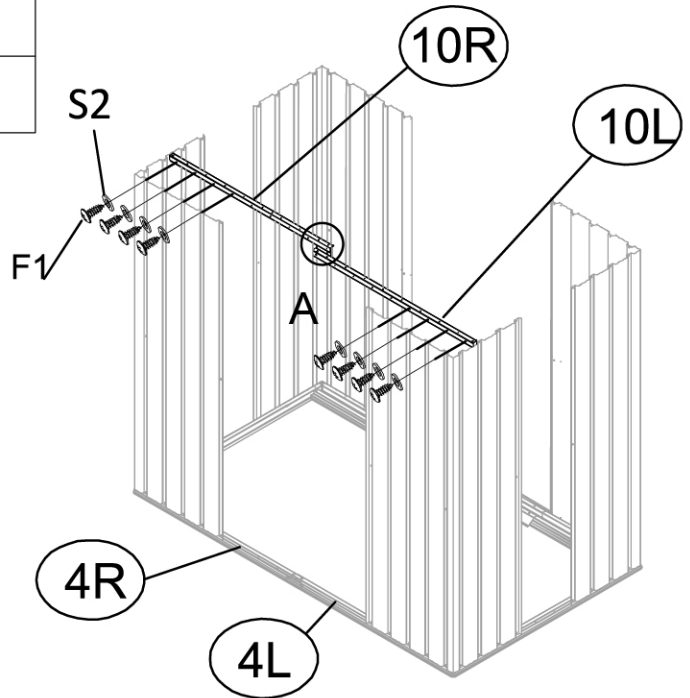
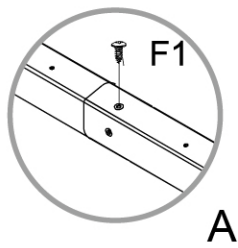

NO.	PART	Qty.	NO.	PART	Qty.
9		1	F1		12
11		1	S2		12

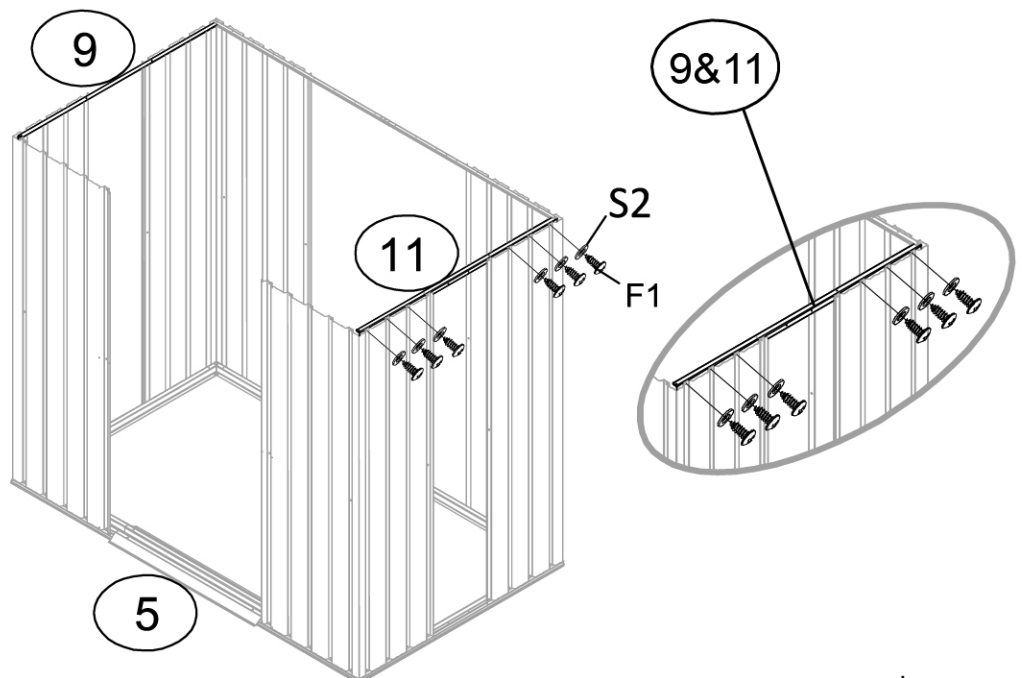

NO.	PART	Qty.	NO.	PART	Qty.
7		1	6		1
8		1	F1		10
G2		4	S2		10

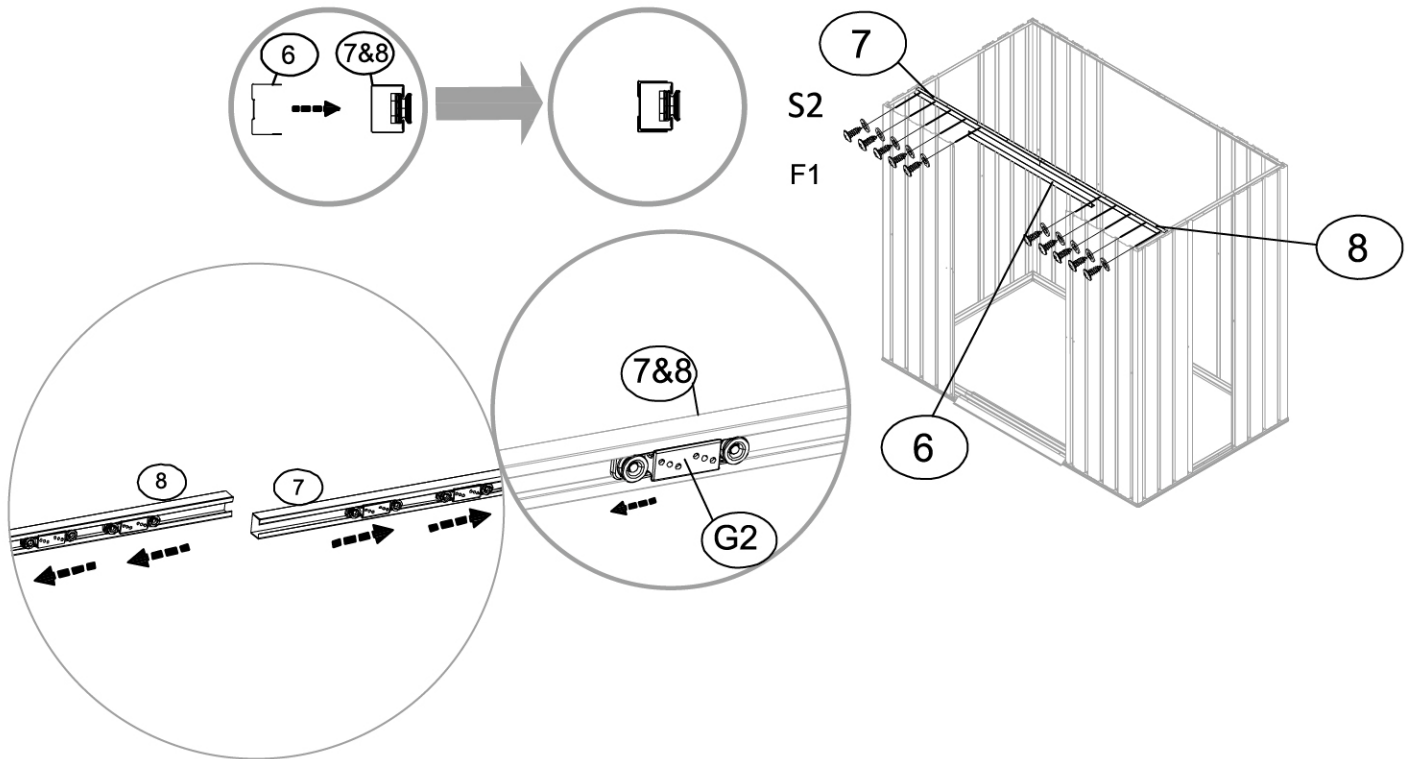

NO.	PART	Qty.
P1A		2
P3		1
25L		1
25R		1
GJ		2
P4		2
F1		42
F2		8
S2		50

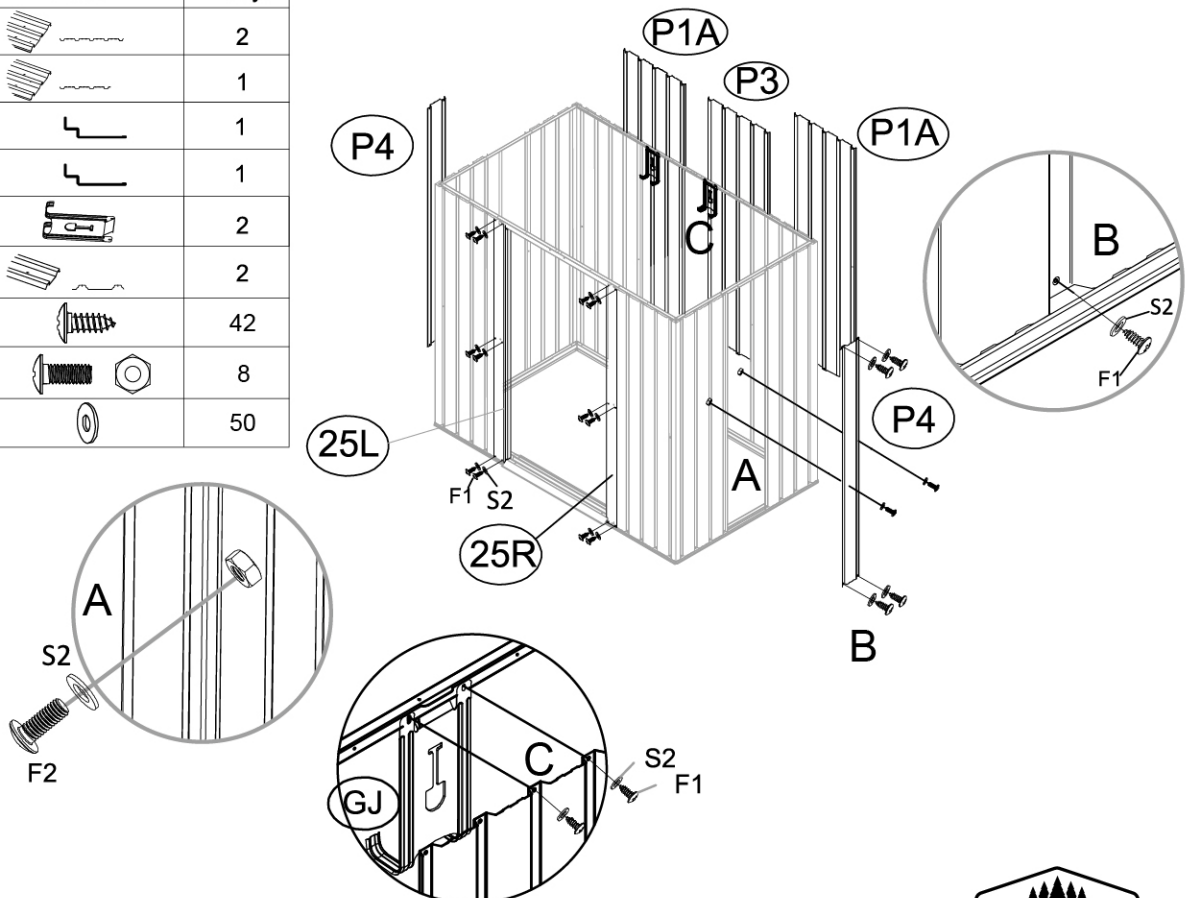



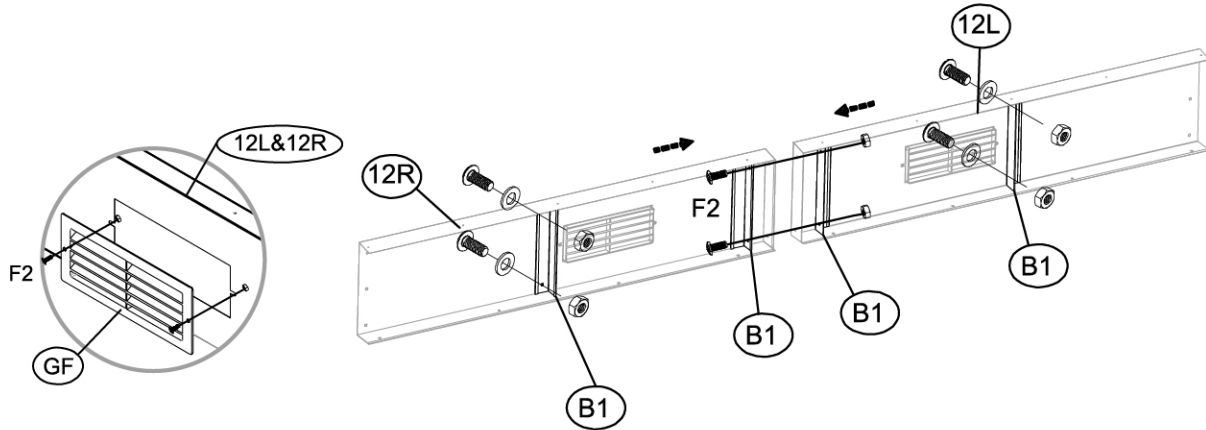

NO.	PART	Qty.	NO.	PART	Qty.
12L		1	B1		4
12R		1	GF		2
F2		10	S2		4

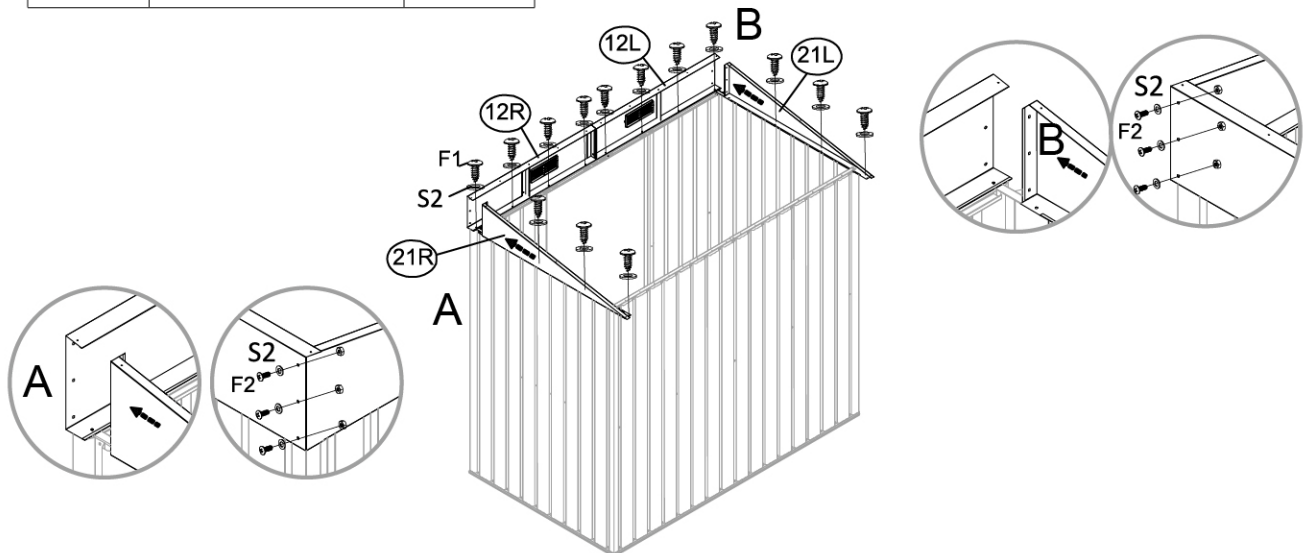





NO.	PART	Qty.
21L		1
21R		1
F1		14
F2		6
S2		20

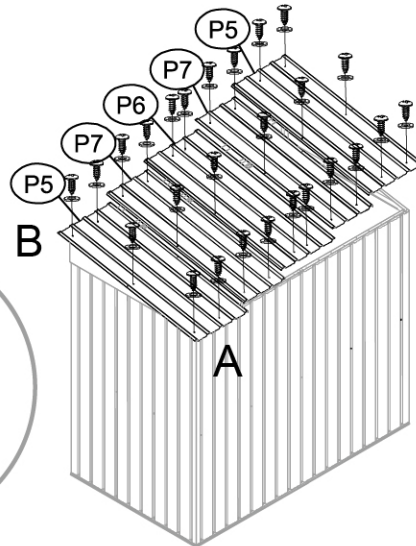
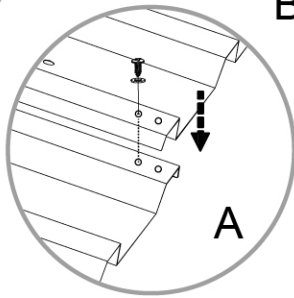
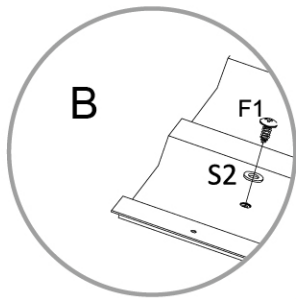





NO.	PART	Qty.
P6		1
P5		2
P7		2
F1		26
S2		26

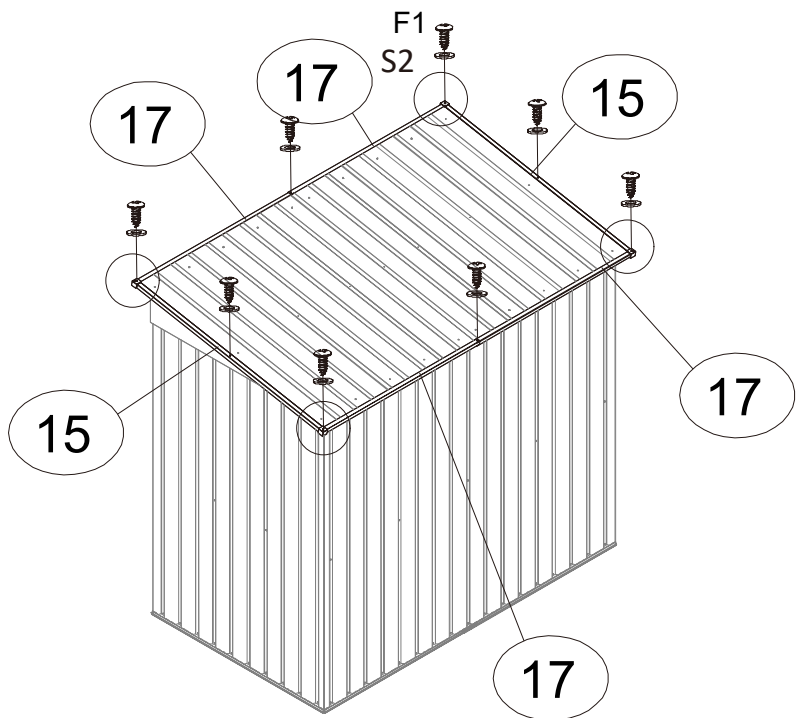
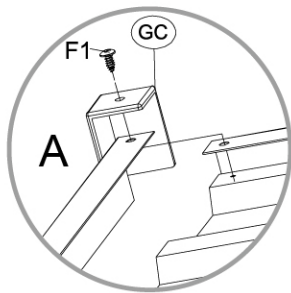

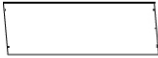



NO.	PART	Qty.
15		2
17		4
GC		4
F1		6
S2		4

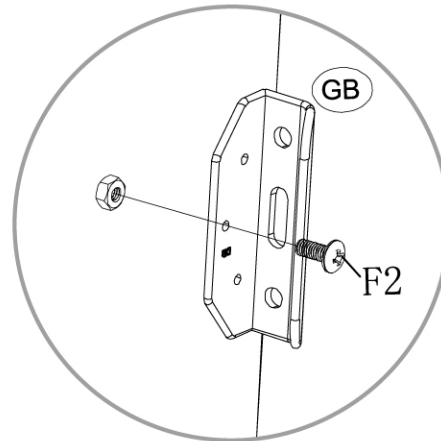
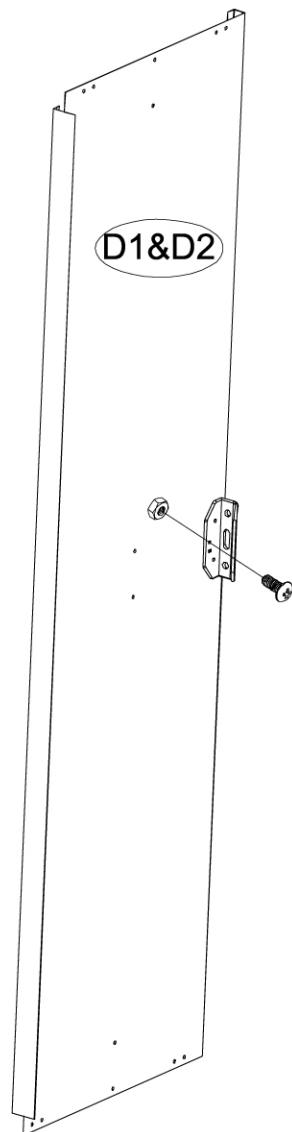

NO.	PART	Qty.
D1		1
D2		1
GB		2
F2		2





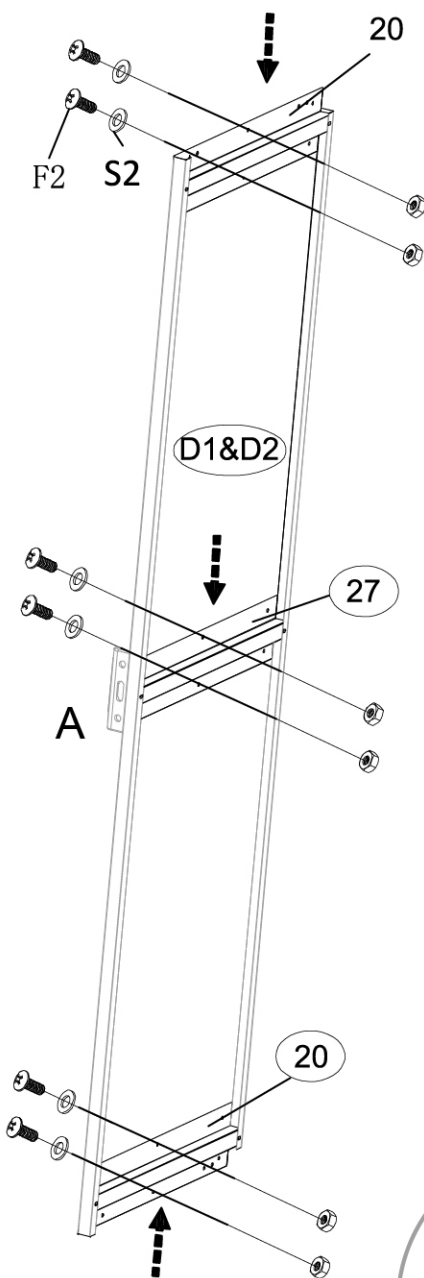

x2

NO.	PART	Qty.
20		4
27		2
F2		36
S2		32

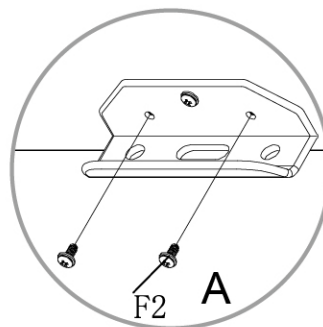

x2



NO.	PART	Qty.
GD		4
F2		4
S2		4

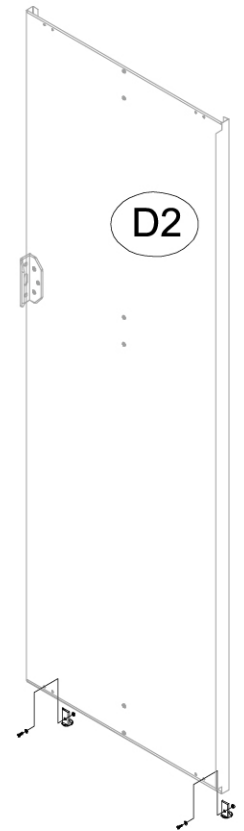
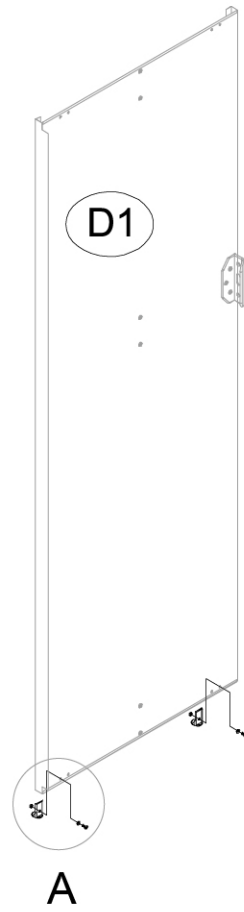
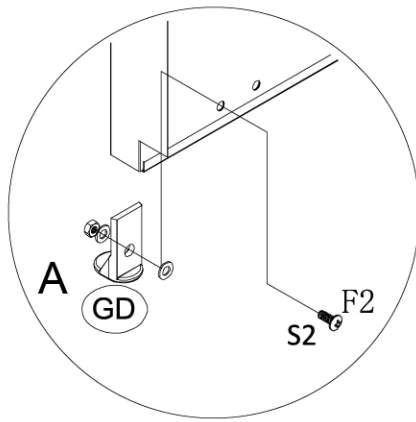

NO.	PART	Qty.
F3		8

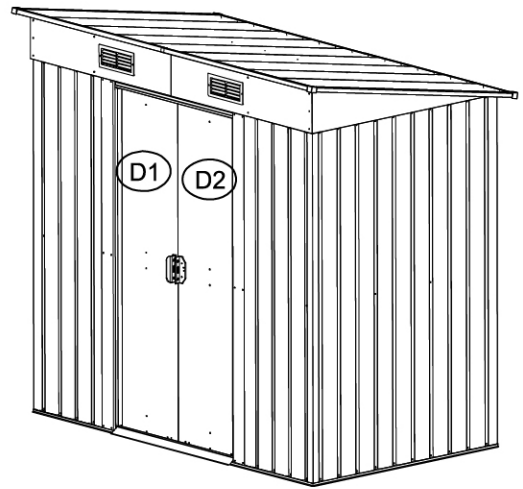
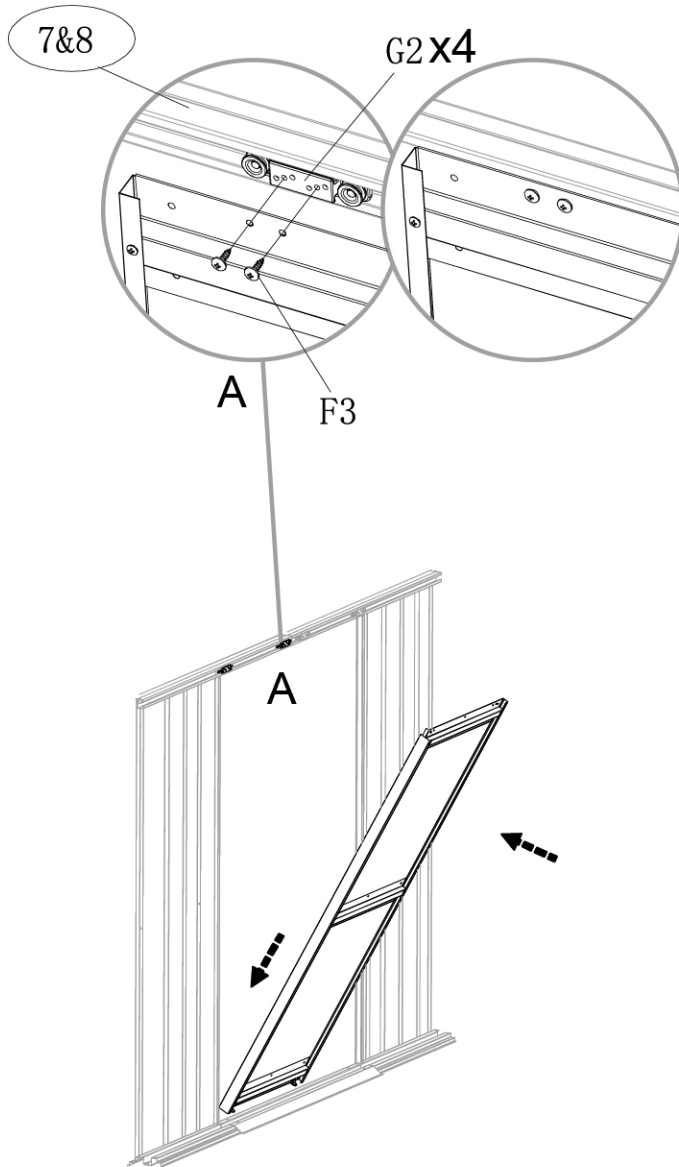

Entsorgung:

Am Ende der langen Lebensdauer Ihres Artikels führen Sie bitte die wertvollen Rohstoffe einer fachgerechten Entsorgung zu, so dass ein ordnungsgemäßes Recycling stattfinden kann. Sollten Sie sich nicht sicher sein, wie Sie am besten vorgehen, helfen die örtlichen Entsorgungsbetriebe oder Wertstoffhöfe gerne weiter.

Disposal:

Once item end-of-life, please dispose valuable raw materials for a proper recycling. If you are not sure how to handle it in a correct way please contact your local disposal or recycling centers for advice.

Mise au rebut:

À la fin de la longue durée de vie de votre article, veuillez mettre au rebut des matières recyclables afin de procéder au recyclage. Si vous n'êtes pas sûr des démarches à suivre, merci de contacter votre communauté d'agglomération ou déchetterie locaux.

Gestión de residuos:

Cuando la vida útil de su artículo haya llegado a su fin, debe usted llevar las materias primas valiosas a un punto de recogida especializado para que el proceso de reciclaje apropiado pueda iniciarse. Si no está seguro de la forma de proceder, lo mejor es que se dirija a una empresa de gestión de residuos local o a una planta de reciclaje.

Smaltimento:

Quando la lunga vita del vostro prodotto giunge al termine, vi preghiamo di provvedere allo smaltimento responsabile delle preziose materie prime, affinché possano essere riciclate nel modo più corretto. In caso di dubbi, vi invitiamo a rivolgervi al centro di raccolta e riciclaggio più vicino a voi.





Deuba – Der Onlinehändler Ihres Vertrauens wenn es um Garten-, Deko und
Haushaltswaren geht. Mit über 4000 Produkten lassen wir Ihr Herz
höher schlagen.

www.DeubaXXL.de



Entdecken Sie täglich Neuheiten und Sonderangebote aus unserem
Sortiment, ein Besuch lohnt sich immer!

Hergestellt für:
Deuba GmbH & Co. KG
Zum Wiesenhof 84 · 66663 Merzig · Germany

Copyright by



Alle Rechte vorbehalten. Ohne schriftliche Zustimmung der Deuba GmbH & Co. KG darf dieses Handbuch, auch nicht auszugsweise, in irgendeiner Form reproduziert werden oder unter Verwendung elektronischer, mechanischer oder chemischer Verfahren vervielfältigt oder verarbeitet werden. Änderungen im Sinne des technischen Fortschritts können jederzeit ohne Ankündigungen vorgenommen werden. Das Handbuch wird regelmäßig korrigiert. Für technische und drucktechnische Fehler und ihre Folgen übernehmen wir keine Haftung.