

ALTO SHAAM®
HALO
HEAT®



**INSTALLATION
OPERATION
AND
MAINTENANCE
MANUAL**

**HEATED
DISPLAY CASES**

**FULL SERVICE OR
SELF SERVICE**

MODEL:

TY-48 Series

W164 N9221 Water Street • P.O. Box 450 • Menomonee Falls, Wisconsin 53052-0450 USA

PHONE: 262.251.3800

800.558-8744 USA/CANADA

FAX: 262.251.7067 • 800.329.8744 U.S.A. ONLY

262.251.1907 INTERNATIONAL

WEBSITE:

www.alto-shaam.com

ALTO-SHAAM® HEATED DISPLAY CASES

UNPACKING & SET-UP

The Alto-Shaam Hot Display Case has been thoroughly tested, checked for calibration, and inspected to insure only the highest quality case is provided. When you receive your display case, check for any possible shipping damage and report it at once to the delivering carrier. See *Transportation Damage and Claims* section located in this manual.

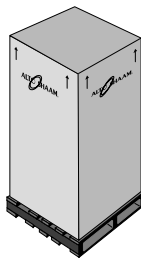

In order to maintain established National Sanitation Foundation standards, all stationary floor models must be sealed to the floor with a R.T.V. or silastic meeting N.S.F. requirements or have 6" (153mm) unobstructed clearance beneath the unit. Counter and table units must be mounted on legs of a sufficient 4" (102mm) height to provide minimum unobstructed space beneath the unit. Legs are supplied with the unit. Warranty will become null and void if these directions are not followed.

Save all the information and instructions packed inside the display case. Complete and return the warranty card to the factory as soon as possible to assure prompt service in the event of a warranty parts and labor claim.

NOTE: Any and all claims for warranty must include the full model and serial number of the display case.

Display case must be installed level. The display case must not be installed in any area where it may be affected by steam, grease, dripping water, high temperatures, or any other severely adverse conditions.

Do not install a heated display case near a cold air source such as a freezer, air conditioning vents, or in any area where outside air fluctuation can affect performance.

ELECTRICAL INSTALLATION

If necessary, permanent wiring or electrical outlets for this display case must be installed by an licensed electrician in accordance with local, country or national codes.

SAMPLE

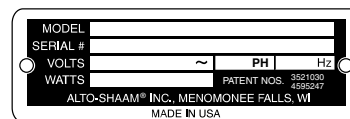

An identification tag is permanently mounted on the case. Plug the case into a properly grounded receptacle **ONLY**. Arcing will occur when connecting or disconnecting the display case unless all controls are in the OFF position. Always position the appliance so the power supply cord is easily accessible in case of emergency.



REGARDING INTERNATIONAL STANDARD UNITS:

If the unit is not equipped with flexible cord with plug, an all-pole country approved disconnection device which has a contact separation of at least 3mm in all poles must be incorporated in the fixed wiring for disconnection. When using a cord without a plug, the green/yellow conductor shall be connected to the terminal which is marked with the ground symbol. If a plug is used, the socket outlet must be easily accessible. If the power cord needs replacement, use a similar one obtained from the distributor.

For 230V units: To prevent an electrical shock hazard between the appliance and other appliances or metal parts in close vicinity, an equalization-bonding stud is provided. An equalization bonding lead must be connected to this stud and the other appliances / metal parts to provide sufficient protection against potential difference. The terminal is marked with the following symbol.



OPERATING PROCEDURES

1. DO NOT ADD WATER TO DISPLAY CASE

Halo Heat display cases maintain a constant but gentle temperature and eliminate much of the moisture loss associated with conventional display cases. Because of this gentle heat, it is not necessary to add water to the display case. As a matter of fact, **adding water is not recommended** since water will accelerate the deterioration of the product, and may damage the unit voiding the warranty.

2. PLACE DIVIDERS AND SERVING PANS IN CASE

Refer to the pan layout diagrams for different types of pan accommodations. A complete pan configuration layout is located in this manual. **It is VERY important to note**, no matter what type of pan configuration chosen, pan separator bars or divider bars must be used to close all gaps between pans, and all gaps between the pans and the edges of the display case. If these gaps are not closed, heat will escape from the bottom of the case into the display area. As a consequence, heat distribution will be uneven and uniform temperature will be difficult to hold. If needed, additional pan divider bars are available. The supplied self-serve pan inserts with wire grids are for use with pre-packaged foods in the self-serve sections of the units.

3. TURN DISPLAY LIGHTS "ON" AND SET THE THERMOSTAT(S) AT NUMBER "10" TO PREHEAT

A indicator light will illuminate when the thermostat(s) is (are) turned "ON." The indicator(s) will remain lit as long as the unit is preheating or calling for heat. The unit should be preheated at the **10** setting for a minimum of 30-45 minutes before loading the case with hot food. When preheating is completed, or whenever the unit reaches any temperature set by the operator between **1** and **10**, the indicator light(s) will go "OUT".

4. LOAD HOT FOODS INTO DISPLAY CASE

Be certain only hot food is transferred into the display case. Before loading food into the case, use a pocket-type meat thermometer to make certain all products have reached an internal temperature of 140° to 160° F (60° to 71°C). If any food product is not at proper serving temperature, use a Halo Heat cooking and holding oven, set at 250° to 275°F (121° to 135°C), or a Combitherm oven to bring the product within the correct temperature range.

- Use hand protection when handling hot items.
- Be certain only hot PREPACKAGED foods in appropriate heat tested containers are used in the self-service section of the display case.
- Do not stack food containers.

5. RESET THERMOSTAT(S) AS NEEDED

After all products are loaded into the display case and the doors are closed, it is necessary to reset the thermostat(s). For fully enclosed sections, reset the thermostat to the number "8" setting. Cases with a self-service section should be maintained between number "9" and number "10" for the self-service section **only**. THESE SETTINGS WILL NOT NECESSARILY BE FINAL. Since proper temperature range depends on the type of products and the quantities being held, it is necessary to periodically use a pocket thermometer to check each item to make certain the correct temperatures are being maintained. Proper temperature range is between a minimum of 140° and 160° F (60° and 71° C). Normally, this will require a thermostat setting of between number "6" and "8" in fully enclosed cases. Self-service cases or sections will always require a higher thermostat setting.

6. PLACEMENT OF FOOD PROBE

If the unit is equipped with the probe accessory, wipe each probe and probe tip with a disposable alcohol pad to clean and sanitize before using. If the probe is left in its bracket, the LED temperature display will indicate the ambient air temperature inside the case. To place a probe into food kept in the case, remove the probe from the bracket and push the probe tip halfway into the product, positioning the tip at the center of the food mass. If placing into solid foods such as meat roast or poultry breasts, push the probe in from a straight downward position or in from the side to the center position. If placing into a semi-liquid or liquid product, the probe cable will probably need to be secured to keep the probe positioned properly. Do not let the probe tip touch the edges or sides. Tape the probe cable to the lip or edge of the container. Wipe each probe tip with a clean paper towel to remove food debris after each use. Follow by wiping probes with a disposable alcohol pad, and return each probe to the proper bracket position.

7. SERVE FRESH HOT FOOD

Keep hot foods looking fresh. Occasionally stir or rotate food as needed. Serve food products in appropriate heat tested packages or containers. Keep display case doors closed after serving. Wipe spills immediately to assure maximum eye appeal and to ease end of the day cleanup.

PAN CONFIGURATIONS • HEATED DISPLAY CASES

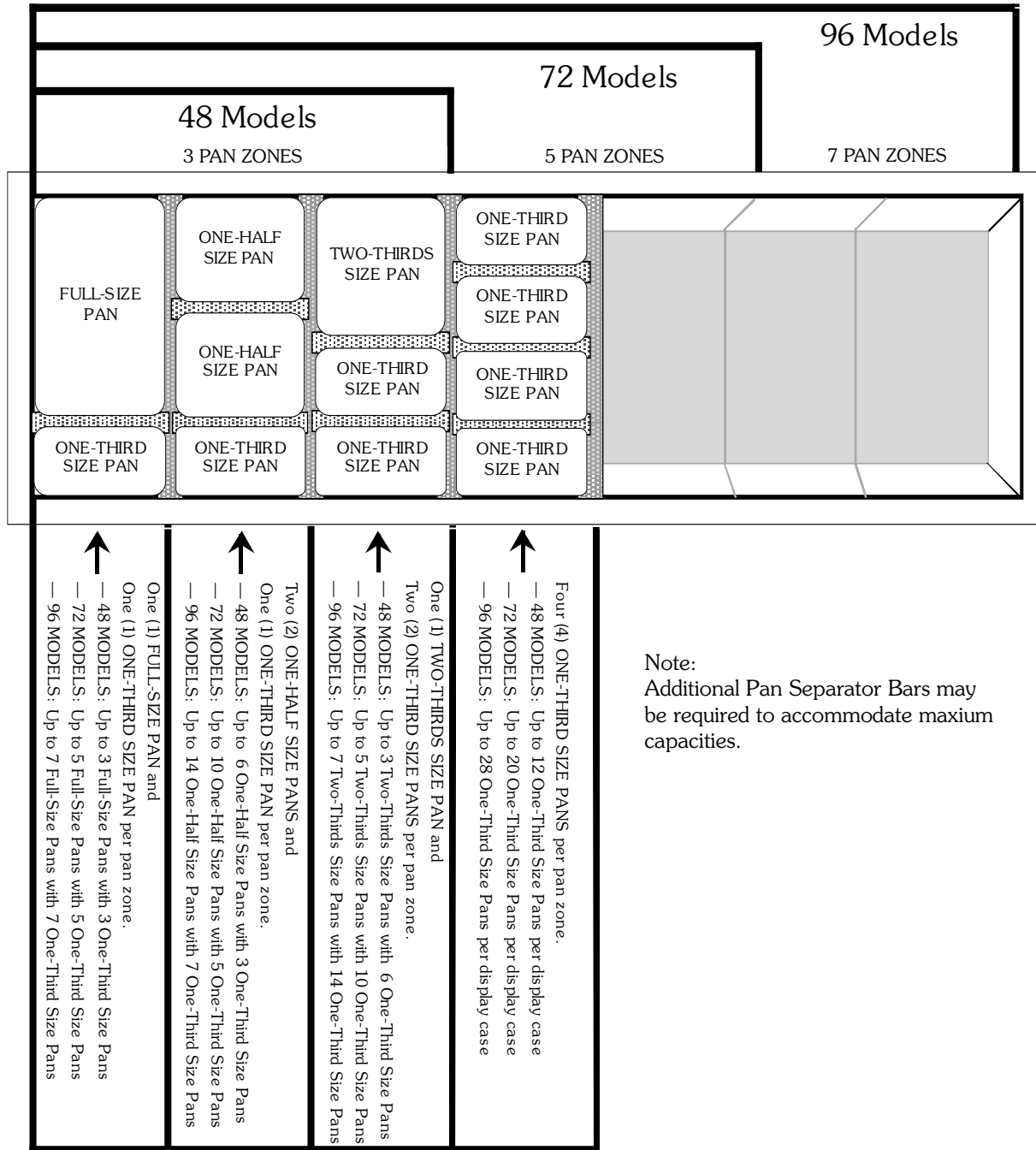

STANDARD PAN DIVIDER & SEPARATOR BARS						
ITEM NO.	DESCRIPTION	SIZE (W x L)	MODELS			
			48	72	96	
11046	SHEET PAN DIVIDER BAR	1-3/8" x 27-13/16" (35 mm x 706 mm)	1	—	—	
11047	ONE-THIRD SIZE PAN	3-1/4" x 7" (83 mm x 178 mm)	1	—	—	
11317	FULL, HALF & THIRD SIZE - LONG	1" x 27-7/8" (25 mm x 708 mm)	2	4	6	
11318	FULL, HALF & THIRD SIZE - SHORT	1" x 13" (25 mm x 330 mm)	9	15	21	
11319	SHEET PAN DIVIDER BAR	3-1/4" x 27-3/16" (83 mm x 706 mm)	1	—	—	
11320	SHEET PAN DIVIDER BAR	1-3/4" x 17-3/4" (45 mm x 451 mm)	2	3	4	
11357	SHEET PAN DIVIDER BAR	5-29/32" x 27-13/16" (150 mm x 706 mm)	—	2	3	
11732	SHEET PAN FILLER	3-3/4" x 27-13/16" (95 mm x 706 mm)	—	—	1	

SHEET PAN CONFIGURATIONS • HOT DISPLAY CASES

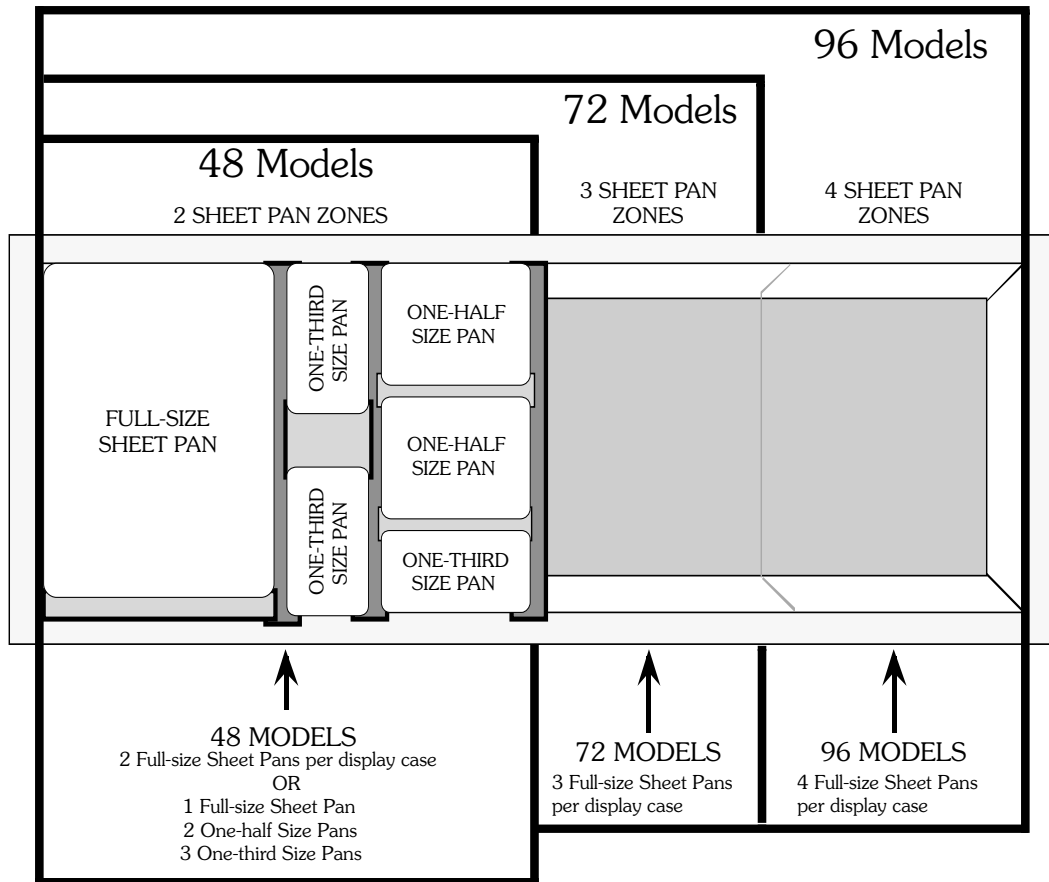

STANDARD PAN DIVIDER & SEPARATOR BARS

ITEM No.	DESCRIPTION	SIZE (W x L)	48 MODELS	72 MODELS	96 MODELS
11046	SHEET PAN DIVIDER BAR	1-3/8" x 27-13/16" (35mm x 706mm)	1	—	—
11047	ONE-THIRD SIZE PAN	3-1/4" x 7" (83mm x 178mm)	1	—	—
11317	FULL, HALF & THIRD SIZE - LONG	1" x 27-7/8" (25mm x 708mm)	2	4	6
11318	FULL, HALF & THIRD SIZE - SHORT	1" x 13" (25mm x 330mm)	9	15	21
11319	SHEET PAN DIVIDER BAR	3-1/4" x 27-3/16" (83mm x 706mm)	1	—	—
11320	SHEET PAN DIVIDER BAR	1-3/4" x 17-3/4" (45mm x 451mm)	2	3	4
11357	SHEET PAN DIVIDER BAR	5-29/32" x 27-13/16" (150mm x 706mm)	—	2	3
11732	SHEET PAN FILLER	3-3/4" x 27-13/16" (95mm x 706mm)	—	—	1
1865	GASTRONORM DIVIDER (220V)	7/8" x 27-7/8" (22mm x 708mm)	2	4	6

OPERATION

GENERAL HOLDING GUIDELINES

Chefs, cooks and other specialized food service personnel employ varied methods of cooking. Proper holding temperatures for a specific food product must be based on the moisture content of the product, product density, volume, and proper serving temperatures. Safe holding temperatures must also be correlated with palatability in determining the length of holding time for a specific product.

Halo Heat maintains the maximum amount of product moisture content without the addition of water, water vapor, or steam. Maintaining maximum natural product moisture preserves the natural flavor of the product and provides a more genuine taste. In addition to product moisture retention, the gentle properties of Halo Heat maintain a consistent temperature throughout the cabinet without the necessity of a heat distribution fan, thereby preventing further moisture loss due to evaporation or dehydration.

HOLDING TEMPERATURE RANGE		
MEAT	FAHRENHEIT	CELSIUS
BEEF ROAST — Rare	140°F	60°C
BEEF ROAST — Med/Well Done	160°F	71°C
BEEF BRISKET	160° — 175°F	71° — 79°C
CORN BEEF	160° — 175°F	71° — 79°C
PASTRAMI	160° — 175°F	71° — 79°C
PRIME RIB — Rare	140°F	60°C
STEAKS — Broiled/Fried	140° — 160°F	60° — 71°C
RIBS — Beef or Pork	160°F	71°C
VEAL	160° — 175°F	71° — 79°C
HAM	160° — 175°F	71° — 79°C
PORK	160° — 175°F	71° — 79°C
LAMB	160° — 175°F	71° — 79°C
POULTRY		
CHICKEN — Fried/Baked	160° — 175°F	71° — 79°C
DUCK	160° — 175°F	71° — 79°C
TURKEY	160° — 175°F	71° — 79°C
GENERAL	160° — 175°F	71° — 79°C
FISH/SEAFOOD		
FISH — Baked/Fried	160° — 175°F	71° — 79°C
LOBSTER	160° — 175°F	71° — 79°C
SHRIMP — Fried	160° — 175°F	71° — 79°C
BAKED GOODS		
BREADS/ROLLS	120° — 140°F	49° — 60°C
MISCELLANEOUS		
CASSEROLES	160° — 175°F	71° — 79°C
DOUGH — Proofing	80° — 100°F	27° — 38°C
EGGS —Fried	150° — 160°F	66° — 71°C
FROZEN ENTREES	160° — 175°F	71° — 79°C
HORS D'OEUVRES	160° — 180°F	71° — 82°C
PASTA	160° — 180°F	71° — 82°C
PIZZA	160° — 180°F	71° — 82°C
POTATOES	180°F	82°C
PLATED MEALS	180°F	82°C
SAUCES	140° — 200°F	60° — 93°C
SOUP	140° — 200°F	60° — 93°C
VEGETABLES	160° — 175°F	71° — 79°C
The holding temperatures listed are suggested guidelines only.		

When product is removed from a high temperature cooking environment for immediate transfer into equipment with the lower temperature required for hot food holding, condensation can form on the outside of the product and on the inside of plastic containers used in self-service applications. Allowing the product to release the initial steam and heat produced by high temperature cooking can alleviate this condition. To preserve the safety and quality of freshly cooked foods however, a maximum of 1 to 2 minutes must be the only time period allowed for the initial heat to be released from the product.

Most Halo Heat holding equipment is provided with a thermostat control between 60° and 200°F (16° to 93°C). If the unit is equipped with vents, close the vents for moist holding and open the vents for crisp holding.

If the unit is equipped with a thermostat indicating a range of between 1 and 10, use a metal-stemmed indicating thermometer to measure the internal temperature of the product(s) being held. Adjust the thermostat setting to achieve the best overall setting based on internal product temperature.

CARE AND CLEANING

The cleanliness and appearance of this equipment will contribute considerably to operating efficiency and savory, appetizing food. Good equipment that is kept clean works better and lasts longer.



1. CLEAN THE PROBES DAILY

If the display case is supplied with probes, remove all food soil from probes. Wipe entire probe and cable assembly with warm detergent solution and a clean cloth. Remove detergent by wiping each probe and cable with clean rinse water and a cloth. Wipe probes with disposable alcohol pad or sanitizing solution recommended for food contact surfaces. Allow probe and cable to air dry in probe holding bracket.



2. THOROUGHLY CLEAN THE UNIT DAILY

- A. Turn lights and adjustable thermostat(s) to the "OFF" position, and disconnect unit from power source.
- B. Remove, cover or wrap, and store unused products under refrigeration.
- C. Clean the interior metal surfaces of the cabinet with a damp clean cloth and any good commercial detergent or grease solvent at the recommended strength. Use a plastic scouring pad or oven cleaner for difficult areas. Rinse well to remove all residue and wipe dry.

NOTE: Avoid the use of abrasive cleaning compounds, chloride based cleaners, or cleaners containing quaternary salts. Never use hydrochloric acid (muriatic acid) on stainless steel.

- D. Clean the glass with a window cleaner. The sliding glass doors are removable allowing for easier cleaning.
- E. To help maintain the protective film coating on polished stainless steel, clean the exterior of the unit with a cleaner recommended for stainless steel surfaces. Spray the cleaning agent on a clean cloth and wipe with the grain of the stainless steel.

Always follow appropriate state or local health (hygiene) regulations regarding all applicable cleaning and sanitation requirements for equipment.

DO NOT USE IF CONTROLS ARE NOT PROPERLY FUNCTIONING

Refer to the Trouble Shooting Guide located in this manual or call an authorized service technician.

CHECK OVERALL CONDITION ONCE A MONTH

Check the case and related cabinets once a month for physical damage and loose screws. Correct any problems before they begin to interfere with the operation of the unit.

SAFETY ALERT



This unit's performance has been optimized using the factory provided bulbs. These bulbs should be replaced with an exact replacement or with a factory recommended replacement. These bulbs have been treated to resist breakage and must be replaced with similarly treated bulbs in order to maintain compliance with NSF standards. Do not over-tighten bulbs in their receptacles as this can cause damage to the bulb filament.



AT NO TIME SHOULD THE INSIDE OR THE OUTSIDE OF THE OVEN BE WASHED DOWN, FLOODED WITH WATER, OR LIQUID SOLUTION. DO NOT USE WATER JET TO CLEAN. NEVER STEAM CLEAN. SEVERE DAMAGE OR ELECTRICAL HAZARD COULD RESULT. WARRANTY BECOMES VOID IF CABINET IS FLOODED.



Hood glass extended to the full upright position is stabilized through the use of gas struts designed for the full load bearing weight. These struts could weaken or fail due to wear, environmental conditions or aging. Operators should be aware of any decrease in effort to lift the hood and initiate an immediate gas strut safety check. **DO NOT LIFT THE HOOD IN THIS CONDITION.**

SANITATION

Food flavor and aroma are usually so closely related that it is difficult, if not impossible, to separate them. There is also an important, inseparable relationship between cleanliness and food flavor. Cleanliness, top operating efficiency, and appearance of equipment contribute considerably to savory, appetizing foods. Good equipment that is kept clean, works better and lasts longer.

Most food imparts its own particular aroma and many foods also absorb existing odors. Unfortunately, during this absorption, there is no distinction between GOOD and BAD odors. The majority of objectionable flavors and odors troubling food service operations are caused by bacteria growth. Sourness, rancidity, mustiness, stale or other OFF flavors are usually the result of germ activity.

The easiest way to insure full, natural food flavor is through comprehensive cleanliness. This means good control of both visible soil (dirt) and invisible soil (germs). A thorough approach to sanitation will provide essential cleanliness. It will assure an attractive appearance of equipment, along with maximum efficiency and utility. More importantly, a good sanitation program provides one of the key elements in the prevention of food-borne illnesses.

A controlled holding environment for prepared foods is just one of the important factors involved in the prevention of food-borne illnesses. Temperature monitoring and control during receiving, storage, preparation, and the service of foods are of equal importance.

The most accurate method of measuring safe temperatures of both hot and cold foods is by internal product temperature. A quality thermometer is an effective tool for this purpose, and should be routinely used on all products that require holding at a specific temperature.

A comprehensive sanitation program should focus on the training of staff in basic sanitation procedures. This includes personal hygiene, proper handling of raw foods, cooking to a safe internal product temperature, and the routine monitoring of internal temperatures from receiving through service.

Most food-borne illnesses can be prevented through proper temperature control and a comprehensive program of sanitation. Both these factors are important to build quality service as the foundation of customer satisfaction. Safe food handling practices to prevent food-borne illness is of critical importance to the health and safety of your customers. HACCP, an acronym for Hazard Analysis (at) Critical Control Points, is a quality control program of operating procedures to assure food integrity, quality, and safety. Taking steps necessary to augment food safety practices are both cost effective and relatively simple. While HACCP guidelines go far beyond the scope of this manual, additional information is available by contacting:

Center for Food Safety and Applied Nutrition
Food and Drug Administration
1-888-SAFEFOOD

INTERNAL FOOD PRODUCT TEMPERATURES		
HOT FOODS		
DANGER ZONE	40° TO 140°F	(4° TO 60°C)
CRITICAL ZONE	70° TO 120°F	(21° TO 49°C)
SAFE ZONE	140° TO 165°F	(60° TO 74°C)
COLD FOODS		
DANGER ZONE	ABOVE 40°F	(ABOVE 4°C)
SAFE ZONE	36°F TO 40°F	(2°C TO 4°C)
FROZEN FOODS		
DANGER ZONE	ABOVE 32°F	(ABOVE 0°C)
CRITICAL ZONE	0° TO 32°F	(-18° TO 0°C)
SAFE ZONE	0°F OR BELOW	(-18°C OR BELOW)

SERVICE VIEWS



Hinge to unit
is lower hinge

Doors
control side – pass thru heated display cases

Hinge to door
is upper hinge

Inside the Control Panel

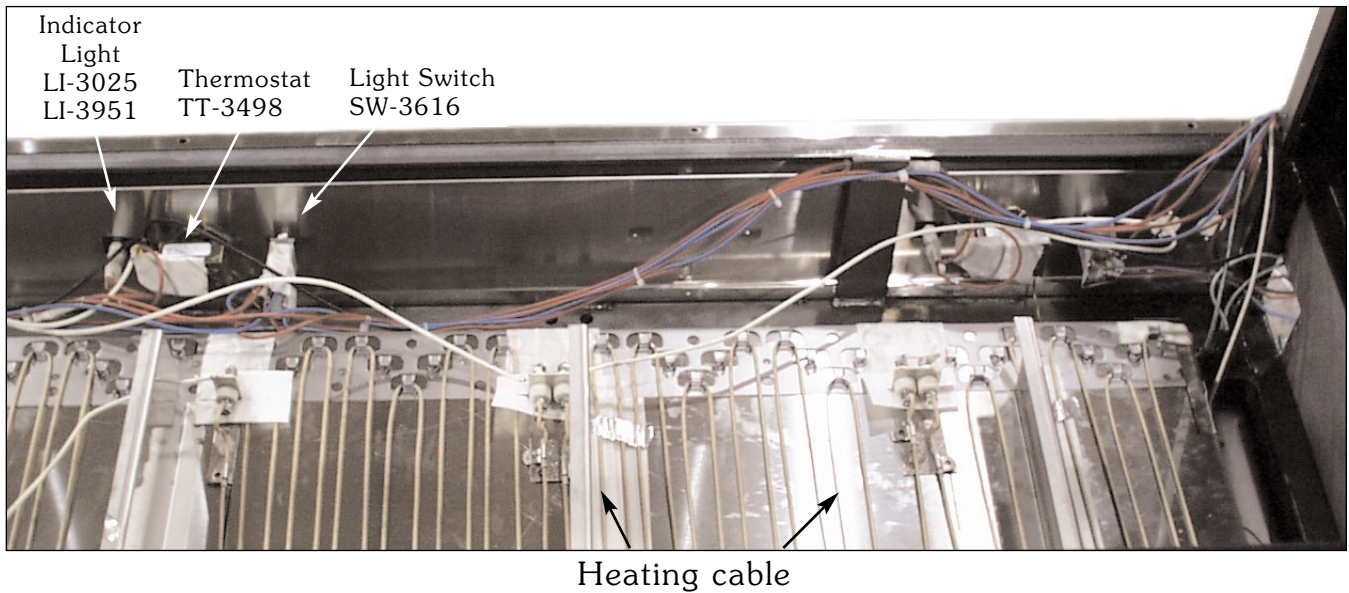

SERVICE VIEWS

Strut Pack Assembly



Strut Packs		
<u>Model Number</u>	<u>A/S Part Number</u>	<u>Qty.</u>
TY/TYSYS-48143482

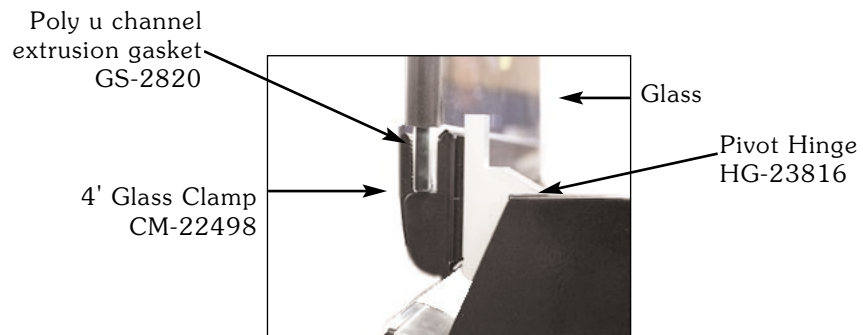

TY-48 SERIES

Power Configurations

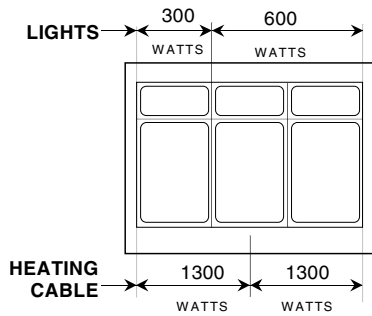

TYSYS-48 • TYSYS-48/P
TOTAL: 3500 Watts (maximum)

TY-48 SERIES ■ CABLE REPLACEMENT KIT SERVICE KIT No. 4880

includes:

CB-3044	Cable Heating Element	134 feet
CR-3226	Ring Connector	4
IN-3488	Insulation Corner	1 foot
BU-3105	Shoulder Bushing	4
BU-3106	Cup Bushing	4
SL-3063	Insulating Sleeve	4
TA-3540	Electrical Tape	1 roll
ST-22439	Stud, 10-32	4
NU-2215	Hex Nut	8

OPTIONS & ACCESSORIES

Bulbs

— 100 Watt, 130V, STANDARD	LP-33592
— 100 Watt, 130V, BLUE TINT	LP-33253
— 100 Watt, 230-250V, STANDARD	LP-3384
Carving Station, Single Well	55299
— with Stainless Steel Drawer Slides	5001874
Gauge, Interior Ambient Temperature	GU-33384
Glass Panes, End, Reflective, Tempered	
— RIGHT-HAND	GL-22539
— LEFT-HAND	GL-22538
Glass, Tempered, End Spacer	GL-22719
Independent Circuit Cordset Pkg. TY, 120/208-240V	14221
Independent Load Center Pkg. Option 120/208-240V - INCLUDES	14220
Load Center	CI-3877
Ground bar kit.	CI-3878
Breaker, 15 Amp.	CI-33071
Connector	CR-3953
Nut	NU-3954
Pan, 4" deep, Self-Service, Pan Insert, 4' long	16358
Pan, Self-Service, 26-7/16" x 45-3/16" x 2"	11624
Pan Grid, Self-Service	PN-22048
Pan Separator Bar	
— Sheet Pan - Long, 1-3/8" x 27-13/16"	11046
— One-Third Size Pan, 3-1/4" x 7"	11047
— Full, Half & Third Size - Long, 1" x 27-7/8"	11317
— Full, Half & Third Size - Short, 1" x 13"	11318
— Sheet Pan - Long, 3-1/4" x 27-3/16"	11319
— Sheet Pan - Short, 1-3/4" x 17-3/4"	11320
Panel, Front Custom Colors TYSYS ONLY	P119
Panels, End	
— Black Patch, TYSYS ONLY	PE-22708
— Solid Black Patch, right-hand, TYSYS ONLY	PE-23674
— Solid Black Patch, left-hand, TYSYS ONLY	PE-23675
Panels, End, Stainless Steel, KIOSK ASSEMBLY, TY ONLY.	14600
Panel, Stainless Steel Front TYSYS ONLY	12644
Product Probe Package: 120/208-240V	5295
Scale Platform Package, right or left hand.	14102

SAFETY ALERT



This unit's performance has been optimized using the factory provided bulbs. These bulbs should be replaced with an exact replacement or with a factory recommended replacement. These bulbs have been treated to resist breakage and must be replaced with similarly treated bulbs in order to maintain compliance with NSF standards. Do not over-tighten bulbs in their receptacles as this can cause damage to the bulb filament.



CAUTION



Hood glass extended to the full upright position is stabilized through the use of gas struts designed for the full load bearing weight. These struts could weaken or fail due to wear, environmental conditions or aging. Operators should be aware of any decrease in effort to lift the hood and initiate an immediate gas strut safety check. **DO NOT LIFT THE HOOD IN THIS CONDITION.**



CAUTION

At no time should the inside or outside of the cabinet be washed down, flooded with water or liquid solution. NEVER STEAM CLEAN. Severe damage or electrical hazard could result.



CAUTION

TY-48 SERIES

PART DESCRIPTION	A/S PT NO.				
		TY-48	TY-48/P	TYSYS-48	TYSYS-48/P
1. END PANEL BOTTOM	13028	1	1	1	1
END PANEL BOTTOM, 230V	13986	1	1	-	-
RIGHT-HAND BOTTOM PANEL, 4' (1219mm)	13029	1	1	1	1
LEFT-HAND BOTTOM PANEL, 4' (1219mm)	13030	1	1	1	1
2. BOTTOM MOUNTING SCREWS	SC-2425	17	17	17	17
BOTTOM MOUNTING SCREWS	SC-2459	4	4	4	4
3. CORD, 6' (1829mm), 120/208-240V	CD-3291	1	1	-	-
CORD (230V)	CD-33490	1	1	-	-
4. PLUG	PG-3267	1	1	-	-
5. CONTROL PANEL MOUNTING SCREWS	SC-2459	3	3	3	3
CONDUIT TUBING, 6" (152mm)	TU-3874			2	2
6. INSULATION, 25.5 x 120" (649mm x 3049mm)	IN-22364	1	1	1	1
7. CABLE CONNECTION HARDWARE					
8. HEATING CABLE, 132' (40234mm)	CB-3045	X	X	X	X
9. THERMOSTAT	TT-3498	2	2	2	2
THERMOSTAT KNOB	KN-3473	2	2	2	2
10. INDICATOR LIGHT (125V)	LI-3025	2	2	2	2
INDICATOR LIGHT (230V)	LI-3951	2	2	2	2
11. BULB SWITCH	SW-3616	2	2	2	2
RUBBER BOOT, 230V	SW-3905				
12. FUSEHOLDER (120/208-240V), <i>INCLUDES</i>	FU-33041	1	1	-	-
FUSE, 15 AMP	FU-3775	1	1	-	-
FUSEHOLDER MOUNTING SCREWS	SC-2425	2	2	-	-
13. CIRCUIT BOX (120/208-240V), <i>INCLUDES</i>	CI-3906	-	-	1	1
BREAKER, 15 AMP	CI-33071	-	-	1	1
GROUND BAR KIT	CI-3878	-	-	1	1
BREAKER, 20 AMP	CI-3907	-	-	2	2
CIRCUIT BOX, (230V), <i>INCLUDES</i>	CI-3906	-	-	1	1
BREAKER, 15 AMP	CI-33071	-	-	2	2
GROUND BAR KIT	CI-3878	-	-	1	1
BREAKER, 20 AMP	CI-3907	-	-	2	2
14. TOP	4379	1	1	1	1
TOP MOUNTING SCREWS	SC-2425	3	3	3	3
TOP MOUNTING SCREWS	SC-2459	3	3	3	3
15. BULB, 120/208-240V	LP-33592	6	6	6	6
BULB, 230V	LP-3384	6	6	6	6
16. BULB SOCKET, 120/208-240V	RP-3952	6	6	6	6
BULB SOCKET, 230V	RP-3955	6	6	6	6
17. DOOR ASSEMBLY					
LEFT HAND GLASS DOOR	DR-22480A	1	1	1	1
RIGHT HAND GLASS DOOR	DR-22480B	1	1	1	1
GUIDES #44049	DR-22480F	8	8	8	8
DOOR BUMPER ASSEMBLY	DR-22480G	1	1	1	1
TOP TRACK	TK-23748	1	1	1	1
BOTTOM TRACK	TK-24265	1	1	1	1
18. END PANEL	PE-22585	2	2	-	-
END PANEL	PE-22493	-	-	2	2
19. CUTTING BOARD ASSEMBLY, <i>INCLUDES</i>	4016	1	1	1	1
CUTTING BOARD BRACKET (BASE)	12069	2	2	2	2
CUTTING BOARD BRACKET MTG. SCREWS	SC-24520	6	6	6	6
CUTTING BOARD BRACKET	BT-2342	2	2	2	2

continued next page--

TY-48 SERIES

PART DESCRIPTION		A/S PT NO.	TY-48	TY-48/P	TYSYS-48	TYSYS-48/P
20.	END GLASS	GL-22479	2	2	2	2
	END GLASS GASKET, 5' (1524mm)	GS-22547	1	1	1	1
21.	FRONT GLASS	GL-22477	1		1	
	FRONT GLASS	GL-22475	-	1	-	1
22.	BASE BOTTOM	1288	-	-	1	1
23.	CUSTOMER GUARD, 4' (1219mm)	11096	-	1	-	1
	SPACER	SP-24586	-	2	-	2
	MOUNTING SCREWS	SC-2073	-	2	-	2
24.	<i>PAN DIVIDER BARS (NOT SHOWN)</i>					
	SHEET PAN	11046	1	-	1	-
	THIRD SIZE PAN	11047	1	-	1	-
	FULL/HALF/THIRD (LONG BAR)	11317	2	-	2	-
	FULL/HALF/THIRD (SHORT BAR)	11318	9	-	9	-
	SHEET PAN	11319	1	-	1	-
	SHEET PAN	11320	2		2	
	<i>PANS (NOT SHOWN)</i>					
	SELF-SERVE PAN	11624	-	1	-	1
	SELF-SERVE PAN GRID	PN-22048	-	2	-	2
25.	ADJUSTABLE LEGS	LG-22686	4	4	-	-
26.	TERMINAL BLOCKS, 4 POS	BK-3597	2	2	-	-
27.	SNAP-IN RECEPTACLES 120/208-240V	RP-3396	2	2	2	2
	RECEPTACLE FUSE, 15 AMP 120/208-240V	FU-33351	1	1	1	1
	RECEPTACLE FUSEHOLDER, 15 AMP 120/208-240V	FU-33352	1	1	1	1
28.	OUTLET HOUSING COVER 120/208-240V	4951	1	1	1	1
29.	4' PROBE PACKAGE OPTION (NOT SHOWN) 120/208-240V	5295	1	1	1	1
30.	FRONT GLASS STRUTS	SU-22702	2	-	2	-
31.	INDEPENDENT CIRCUIT CORDSET, OPTION	14221	1	1	-	-
	(NOT SHOWN) NOT CSA APPROVED 120/208-240V		-	-	-	-
32.	INDEPENDENT LOAD CENTER PACKAGE, OPTION (NOT SHOWN) 120/208-240V	14220	-	-	1	1



**Disconnect the unit from the power source
before cleaning or servicing.**

TYSYS-48/P
SERVICE VIEW
REV: 7/24/97

06/08/94

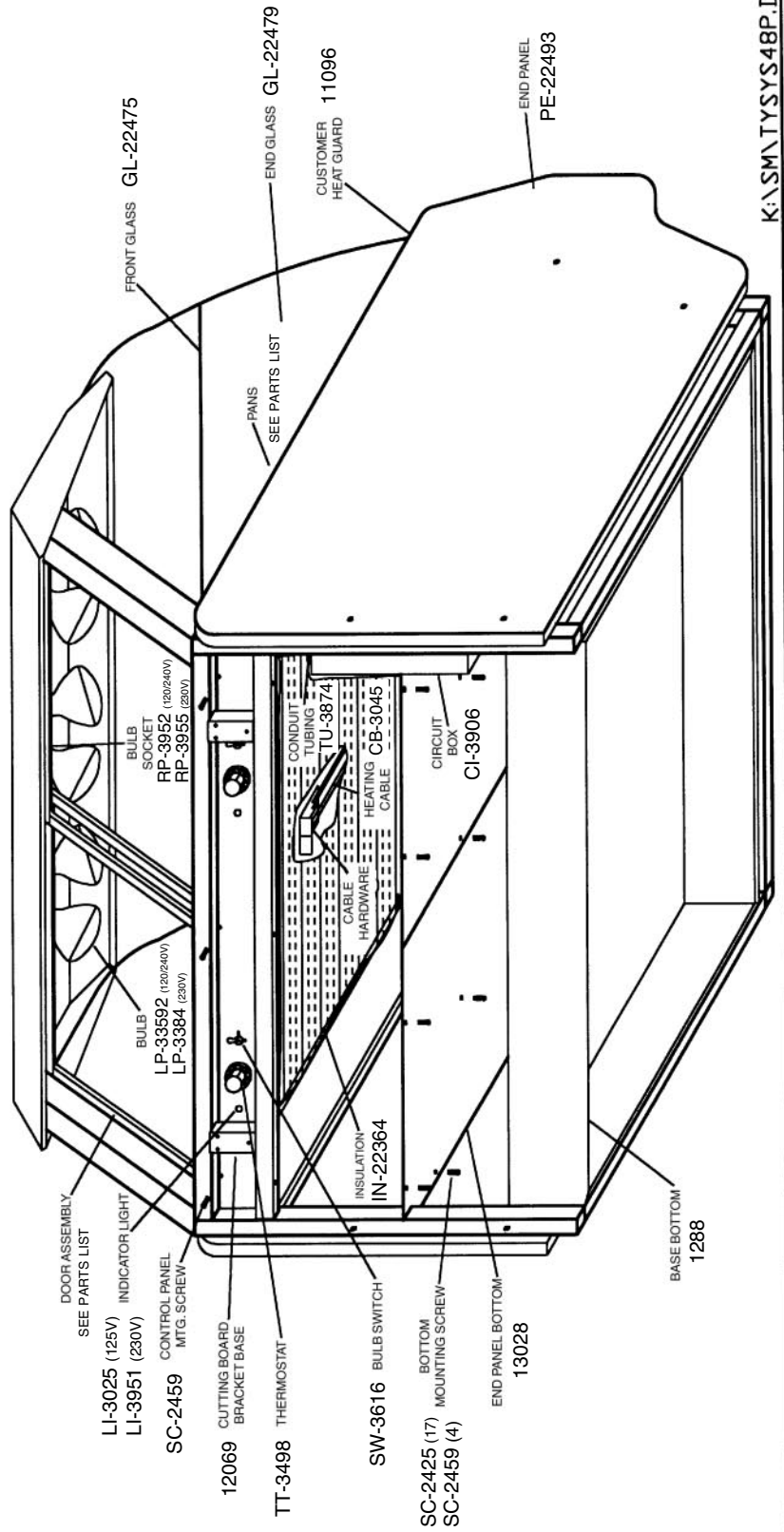
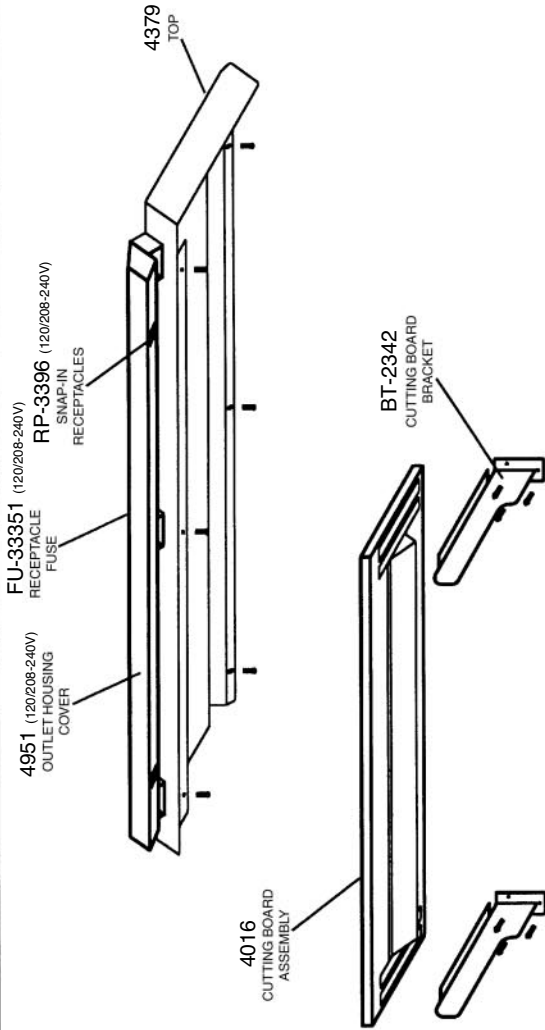

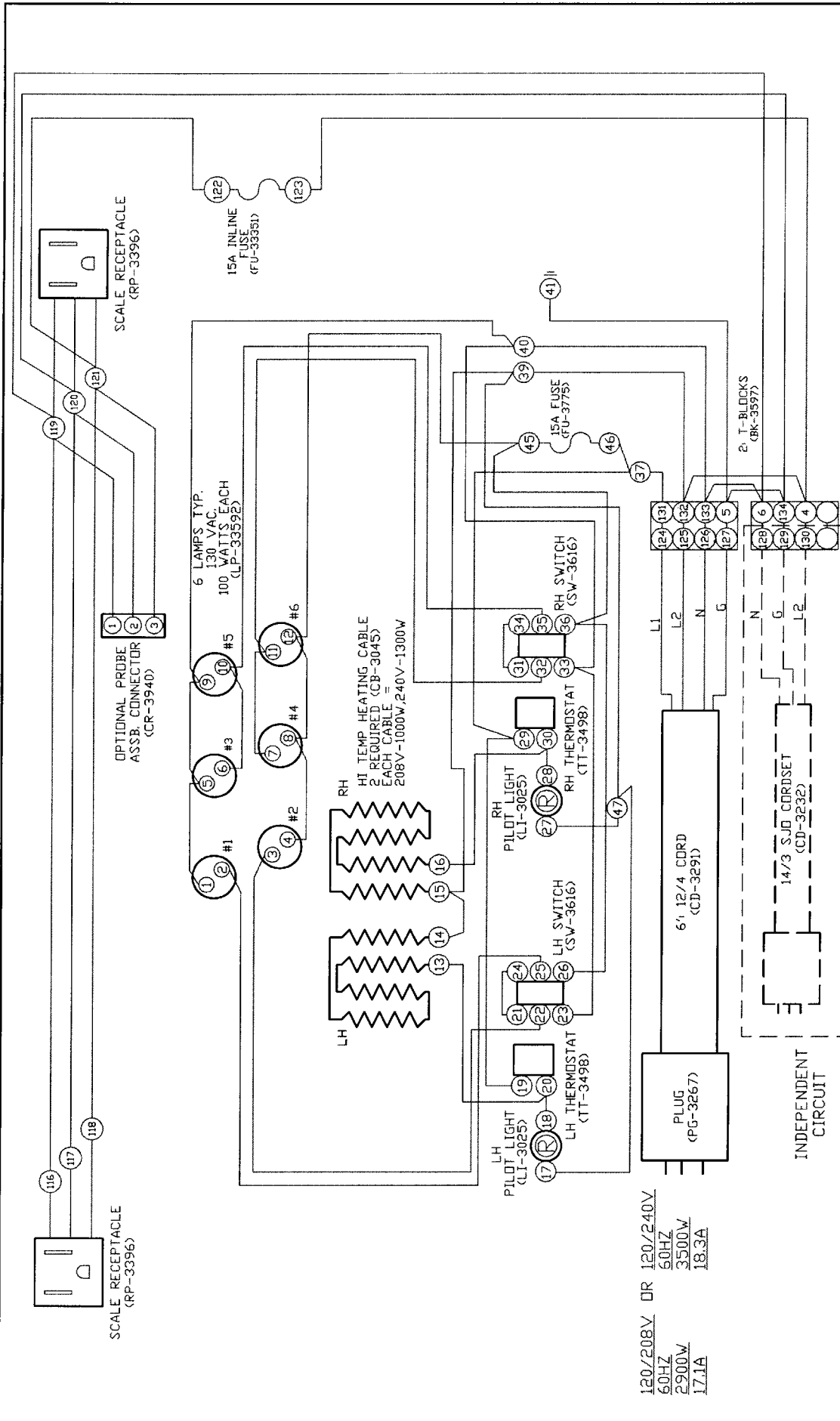

REVISIONS		HN, TY-48, 48/P		120/208-240V	
NO.	DATE	BY			
1	04/04/94	LRP			
2	07/19/94	RS			
3	02/05/97	RS			
4	01/15/01	NW	SCALE 1/2"=1"	DWG. NO.	A-7361
5				DATE 9/15/93	

WIRING DIAGRAM

ALTO-SHAAM INC.
MEMONONEE FALLS, WISCONSIN

DRAWN BY RS
APP'D DAR

NOTE #1: ALL NUMBERS IN () = ALTO-SHAAM PART NO'S
NOTE #2: SEE DRW. #B-8685 FOR HN WIRE ASSEMBLIES
NOTE #3: SEE DRW. #B-8902 FOR TY WIRE ASSEMBLIES

230 VOLT 3100W
50/60HZ 14.1A

6 LAMPS TYP.
230 VAC.
150 WATTS MAX. EACH

6' 12/3 CORD
{HN=CD-3607}
{TY=CD-33490}

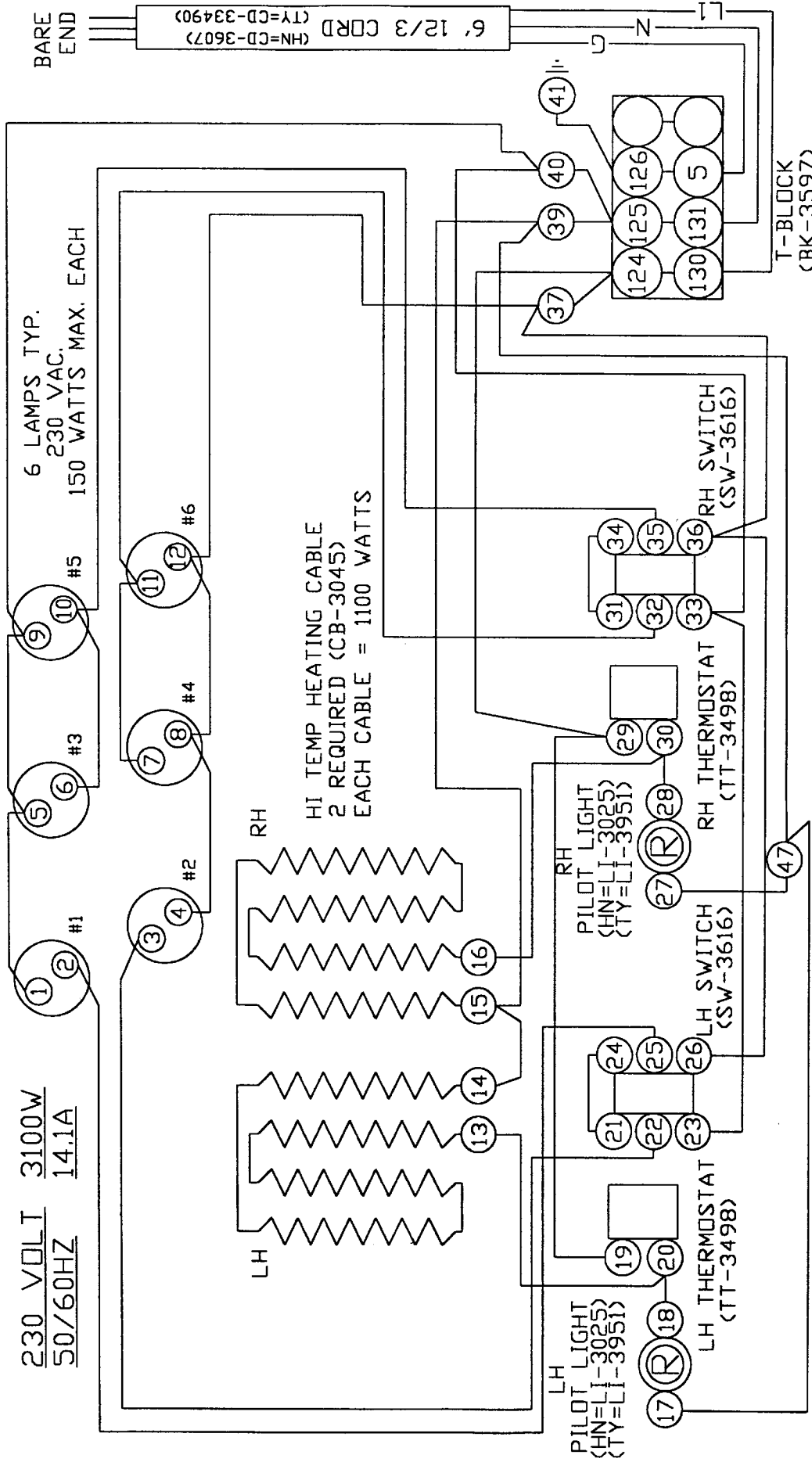

HI TEMP HEATING CABLE
2 REQUIRED (CB-3045)
EACH CABLE = 1100 WATTS

REVISIONS		HN,TY-48,48/P		230V,50HZ	
NO.	DATE	BY			
1	02/06/97	RS			
2	06/18/98	RS			
3	03/02/99	JMM			
4					
5					

WIRING DIAGRAM

ALTO-SHAAM INC.
MENDOTA FALLS, WISCONSIN

DRAWN BY RS SCALE NONE DWG. NO. A-7396
APP'D MSM DATE 11/21/94

NOTE #1: ALL NUMBERS IN ○ = ALTO-SHAAM PART NO'S
NOTE #2: SEE DRW. #B-8719 FOR WIRE ASSEMBLIES

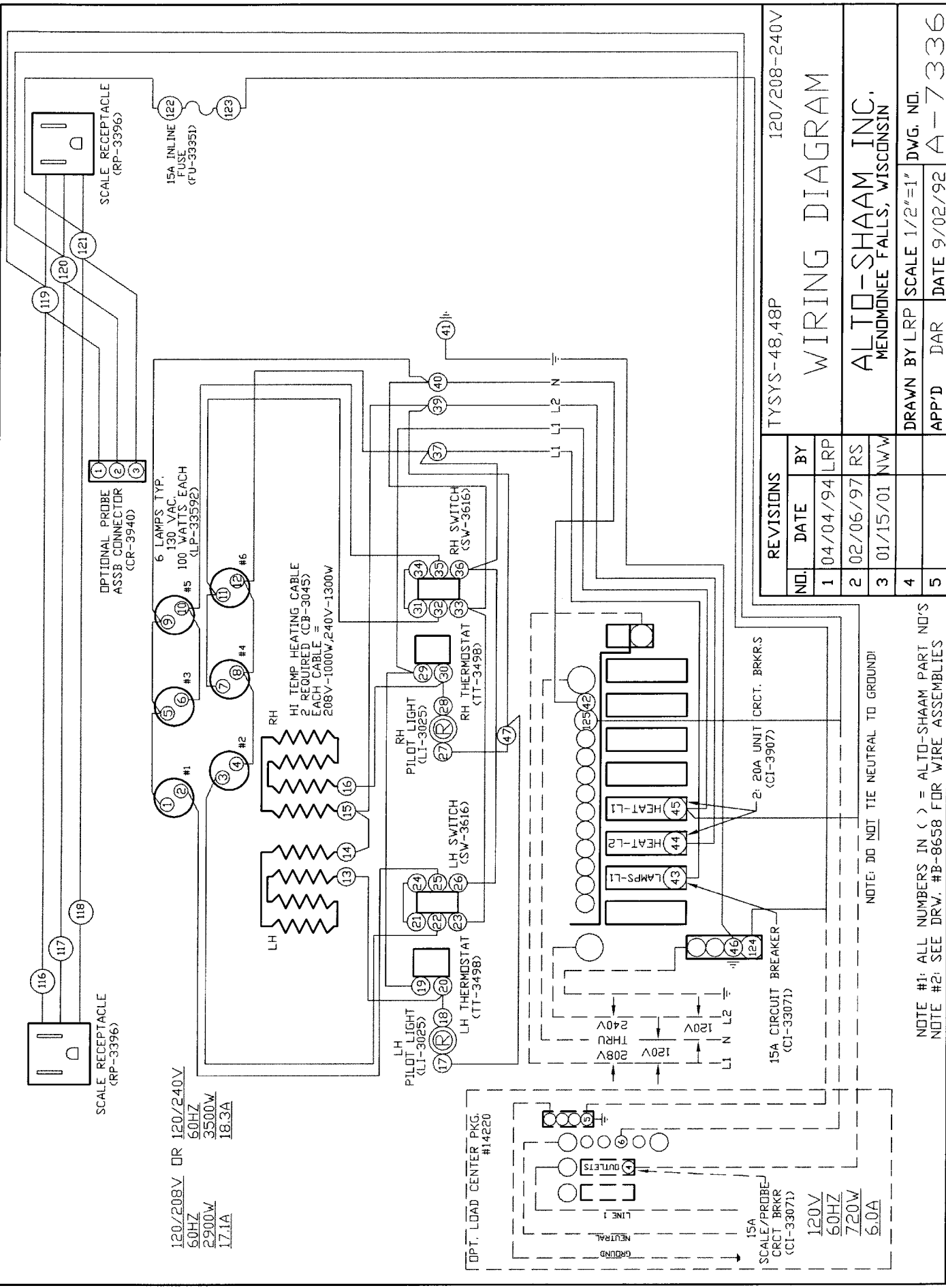

REVISIONS		TYSYS-48,48P		120/208-240V	
NO.	DATE	BY			
1	04/04/94	LRP			
2	02/06/97	RS			
3	01/15/01	NW			
4					
5					

WIRING DIAGRAM

ALTO-SHAAM INC.
 MENOMONEE FALLS, WISCONSIN

DRAWN BY LRP	SCALE 1/2"=1"	DWG. NO. A-7336
APP'D DAR	DATE 9/02/92	

NOTE #1: ALL NUMBERS IN () = ALTO-SHAAM PART NO'S
 NOTE #2: SEE DRW. #B-8658 FOR WIRE ASSEMBLIES

230V
50/60HZ
3100W
14.1A

6 LAMPS TYP.
230 VAC.
150 WATTS MAX. EACH

LH
RH
HI TEMP HEATING CABLE
2 REQUIRED (CB-3045)
EACH CABLE @ 230V = 1100W

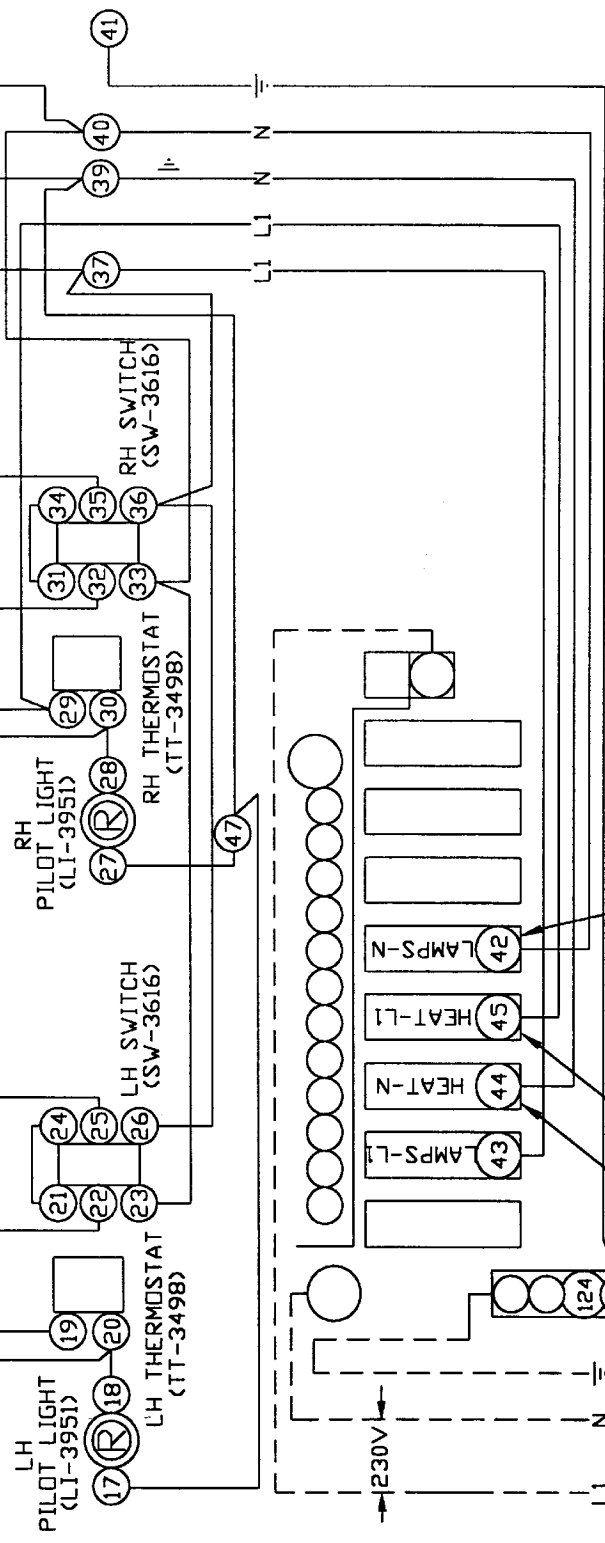

REVISIONS		TYSYS-48/48P		230V, 50/60HZ	
NO.	DATE	BY			
1	04/04/94	LRP			
2	02/11/97	RS			
3	06/18/98	RS			
4	03/02/99	JMM			
5					

2: 15A CIRCUIT BREAKERS (CI-33071)

2: 20A UNIT CIRCUIT BREAKERS (CI-3907)

WIRE-DIAGRAM

ALTO-SHAAM INC.
MEMONEE FALLS, WISCONSIN

DRAWN BY RS
APP'D MSM
SCALE 1/2"=1'
DATE 3/31/93

DWG. NO.
A-7352

NOTE #1: ALL NUMBERS IN () = ALTO-SHAAM PART NO'S
NOTE #2: SEE DRV. #B-8777 FOR WIRE ASSEMBLIES

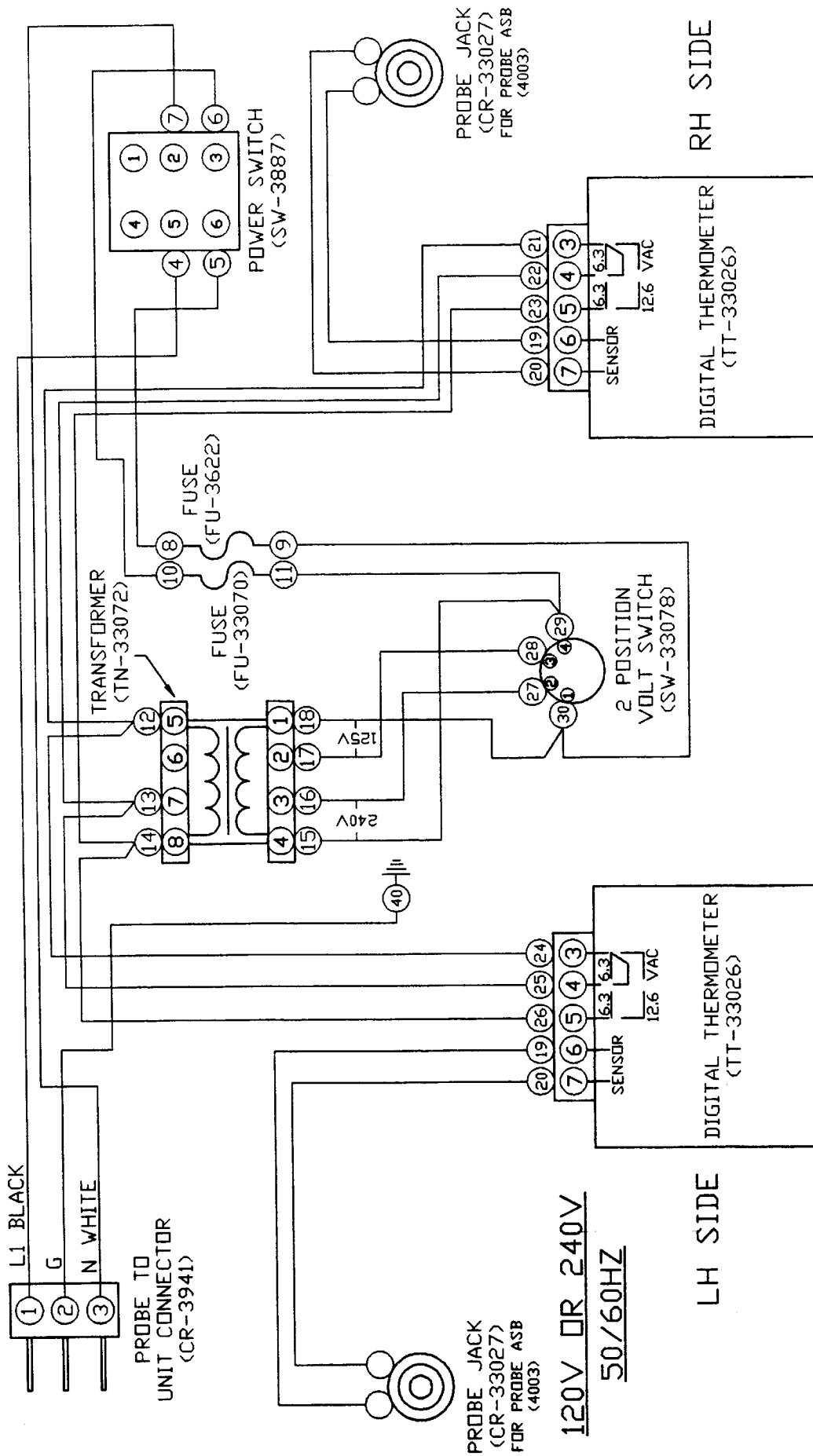

REVISIONS		HN, TY, HNSYS, TYSYS-48, 48P		4' PROBE OPT	
NO.	DATE	BY	72PR, 72PL		
1					
2					
3					
4					
5					

WIRING DIAGRAM

ALTO-SHAAM INC.
MENDOTA FALLS, WISCONSIN

DRAWN BY LRP	SCALE 3/4"=1"	DWG. NO.
APP'D	DATE 04/08/94	A-7370

NOTE #1: ALL NUMBERS IN () = ALTO-SHAAM PART NO'S
 NOTE #2: SEE DRW. #B-8699 FOR WIRE ASSEMBLIES

TRANSPORTATION DAMAGE and CLAIMS



All Alto-Shaam equipment is sold F.O.B. shipping point, and when accepted by the carrier, such shipments become the property of the consignee.

Should damage occur in shipment, it is a matter between the carrier and the consignee. In such cases, the carrier is assumed to be responsible for the safe delivery of the merchandise, unless negligence can be established on the part of the shipper.

1. Make an immediate inspection while the equipment is still in the truck or immediately after it is moved to the receiving area. Do not wait until after the material is moved to a storage area.
2. Do not sign a delivery receipt or a freight bill until you have made a proper count and inspection of all merchandise received.
3. Note all damage to packages directly on the carrier's delivery receipt.
4. Make certain the driver signs this receipt. If he refuses to sign, make a notation of this refusal on the receipt.
5. If the driver refuses to allow inspection, write the following on the delivery receipt:
Driver refuses to allow inspection of containers for visible damage.
6. Telephone the carrier's office immediately upon finding damage, and request an inspection. Mail a written confirmation of the time, date, and the person called.
7. Save any packages and packing material for further inspection by the carrier.
8. Promptly file a written claim with the carrier and attach *copies* of all supporting paperwork.

We will continue our policy of assisting our customers in collecting claims which have been properly filed and actively pursued. We cannot, however, file any damage claims for you, assume the responsibility of any claims, or accept deductions in payment for such claims.

ALTO-SHAAM® LIMITED WARRANTY

Alto-Shaam, Inc. warrants to the original purchaser that any original part that is found to be defective in material or workmanship will, at our option, subject to provisions hereinafter stated, be replaced with a new or rebuilt part.

The labor warranty remains in effect one (1) year from installation or fifteen (15) months from the shipping date, whichever occurs first.

The parts warranty remains in effect one (1) year from installation or fifteen (15) months from the shipping date, whichever occurs first.

Exceptions to the one year part warranty period are as listed:

- A. Halo Heat cook/hold ovens include a five (5) year parts warranty on the heating element. Labor will be covered under the terms of the standard warranty period of one (1) year or fifteen (15) months.
- B. Alto-Shaam Quickchillers include a five (5) year parts warranty on the refrigeration compressor. Labor will be covered under the terms of the standard warranty period of one (1) year or fifteen (15) months.

This warranty does not apply to:

1. Calibration
2. Replacement of light bulbs and/or the replacement of display case glass due to damage of any kind.
3. Equipment damage caused by accident, shipping, improper installation or alteration.
4. Equipment used under conditions of abuse, misuse, carelessness or abnormal conditions.
5. Any losses or damage resulting from malfunction, including loss of product or consequential or incidental damages of any kind.
6. Equipment modified in any manner from original model, substitution of parts other than factory authorized parts, removal of any parts including legs, or addition of any parts.

This warranty is exclusive and is in lieu of all other warranties, expressed or implied, including the implied warranties of merchantability and fitness for purpose. In no event shall the Company be liable for loss of use, loss of revenue, or loss of product or profit, or for indirect or consequential damages. This warranty is in lieu of all other warranties expressed or implied and Alto-Shaam, Inc. neither assumes or authorizes any persons to assume for it any other obligation or liability in connection with Alto-Shaam equipment.

ALTO-SHAAM, INC.

Warranty effective January 1, 2000

Record the model and serial numbers of the unit for easy reference. Always refer to both model and serial numbers in your correspondence regarding the unit.

Model: _____
Serial Number: _____
Purchased From: _____
Date Installed: _____ Voltage: _____

HALO HEAT COOK/HOLD/SERVE SYSTEMS BY ALTO-SHAAM®

W164 N9221 Water Street • P.O. Box 450 • Menomonee Falls, Wisconsin 53052-0450 • U.S.A.

PHONE: 262.251.3800

FAX: 262.251.7067 • 800.329.8744 U.S.A./CANADA WEBSITE:

800.558.8744 U.S.A./CANADA

262.251.1907 INTERNATIONAL

www.alto-shaam.com