

CONTENTS

- 1 DATA SHEET
- 2 INSTALLATION
- 3 WIRING DIAGRAMS
- 4 RISKS WHEN IN USE
- 5 SPARE PARTS
- 6 MAINTENANCE - CLEANING
- 7 WORKING LIFE
- 8 SERVICING

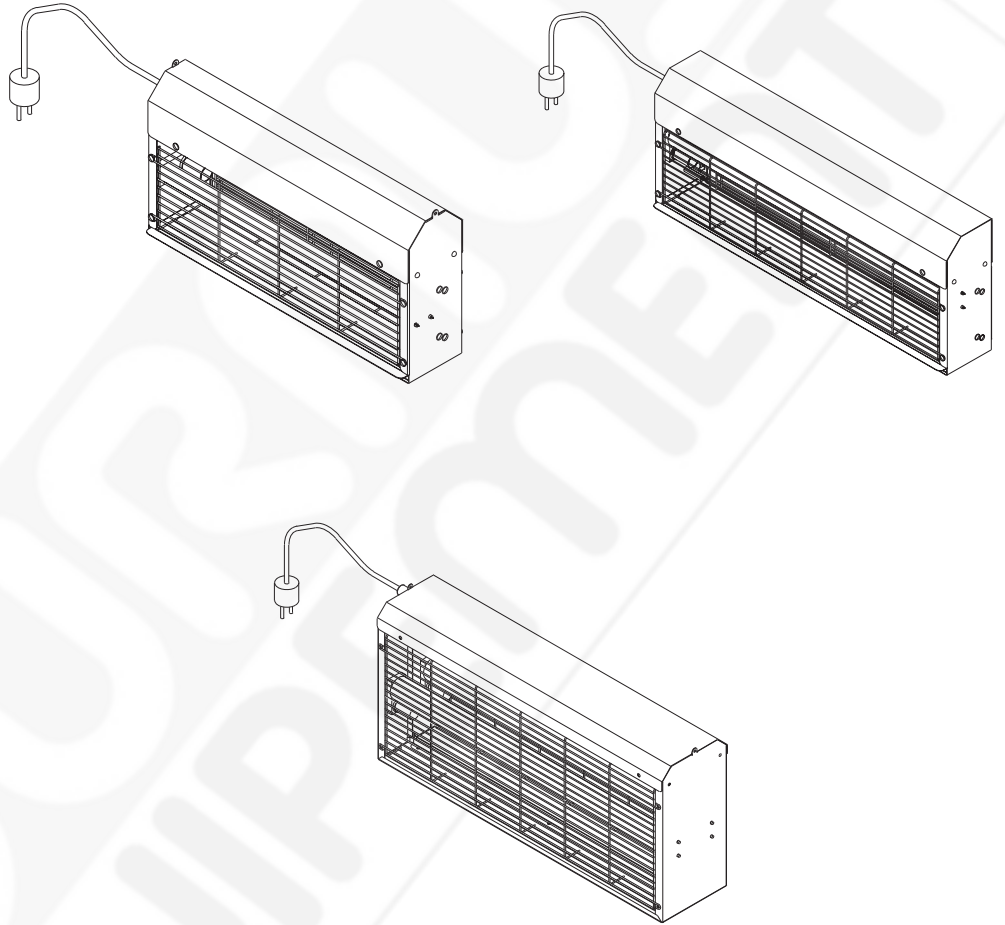

INSTALLATION
ENGINEER'S STAMP



ELECTRIC INSECT KILLERS



**APPLIANCES FOR USE
INDOORS ONLY**

TECHNICAL SPECIFICATIONS:

- Made completely of stainless steel
- Stainless steel wire electrocution grids and protective grid
- Power supply cable, length 1.20 m.
- Stainless steel suspension chain (for suspended model)
- Long effective life (5000 hours) actinic tubes
- Power supply voltage 230 V - 50 Hz
- Protection index: IP 21
- Complies with standard NF EN 60335-1
NF EN 60335-2-59

OPERATING PRINCIPLE

- The light source comes from the special (actinic) fluorescent tubes.
- The UV radiation attracts the insects which are electrocuted on contact with the inner grids. These are powered by a transformer supplying high voltage at low intensity (4,000 V for 9 mA).
- The electrocuted insects fall into a removable collection tray at the bottom of the appliance.

Suspended models

Description	Reference	Dimensions (mm) l x H x W	Actinic tubes	Input power	Weight (kg)	Surface protected
15W suspended electric insect killer	806 941	460 x 235 x 96	1 x 15 W	40 W	4,4	40 m ²
30W suspended electric insect killer	806 943	460 x 285 x 111	2 x 15 W	50 W	4,9	80 m ²
40W suspended electric insect killer	806 945	615 x 330 x 111	2 x 20 W	63 W	6,2	90 m ²
80W suspended electric insect killer	806 947	615 x 330 x 111	2 x 40 W	98 W	6,8	180 m ²

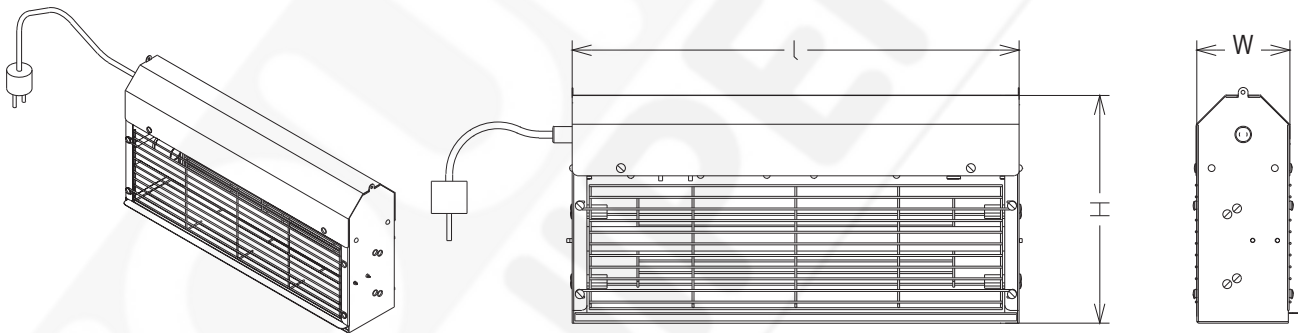

Wall model

Description	Reference	Dimensions (mm) l x H x W	Actinic tubes	Input power	Weight (kg)	Surface protected
40W wall electric insect killer	806 952	615 x 240 x 96	1 x 40 W	53 W	5,6	50 m ²

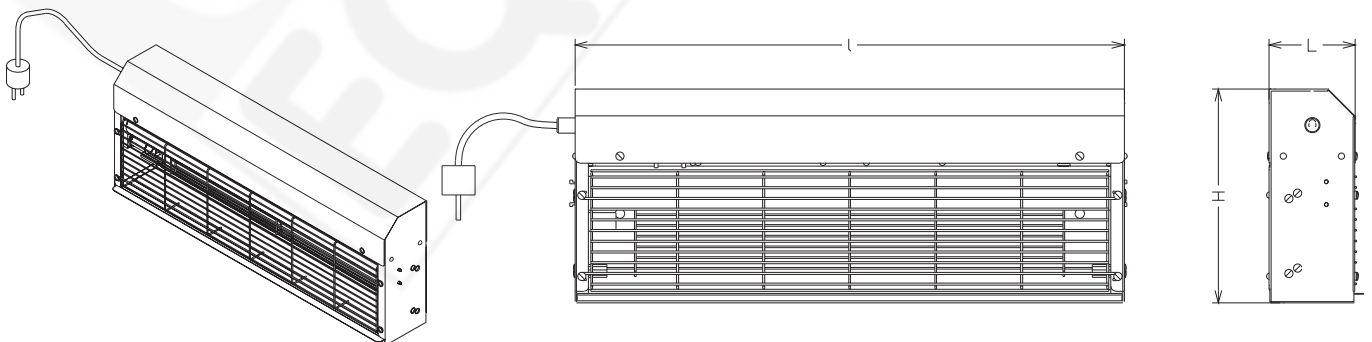

GLUE INSECT KILLERS



TECHNICAL SPECIFICATIONS:

- Made completely of food quality stainless steel
- Glue plate
- Power supply cable, length 1.20 m
- Stainless steel suspension chain (for suspended model)
- Complies with standard NF EN 60335-1
NF EN 60335-2-59

- Long effective life (5000 hours) actinic neon tubes
- Power supply voltage 230 V - 50 Hz
- Protection index: IP 21

OPERATING PRINCIPLE

- The light source comes from the special (actinic) fluorescent tubes.
- The UV radiation attracts the insects which then get stuck on a plate of glue.

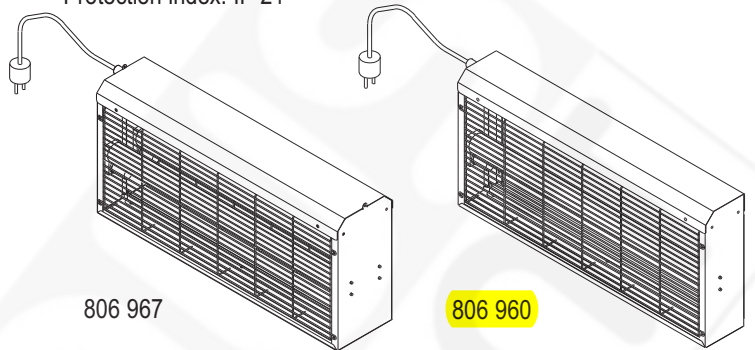

Désignations	Références	Dimensions (mm) l x H x L	Tubes actiniques	Puissance absorbée	Poids (kg)	Surface protégée
Désinsectiseur suspendu à glu 80W	806 967	615 x 285 x 142	2 x 40 W	98 W	5,5	180 m ²
Désinsectiseur mural à glu 40W	806 960	615 x 285 x 97	1 x 40 W	53 W	4,6	50 m ²

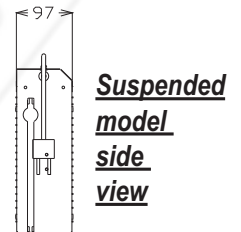
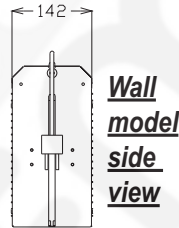
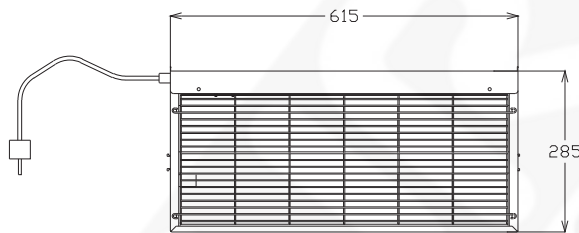

INSTALLATION

Place :

The insect killers should be fixed to a wall or hung, about two meters from the floor, away from sunlight and sources of light. Make sure that the insect killers is placed between the insects entry point into the room and the area you want to protect. Electric insect killers should not be used in premises or sites there are inflammable fumes or explosive dust. They should not be used in barns, stables or similar places either.

siting example :

As each case is different, here is a diagram to illustrate the positioning procedure.

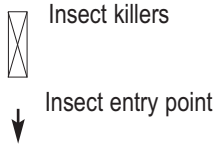

Electric connection :

The surface socket to which the insect killers will be connected must be protected by a 15 mA differential circuit breaker and have an omnipolar cutout device. **This socket must be earthed.**

WIRING DIAGRAMS

ELECTRIC INSECT KILLERS

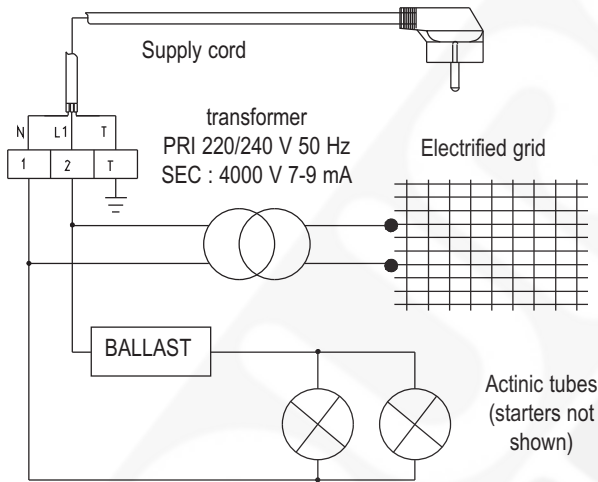

WIRING DIAGRAM (except model 806 947)

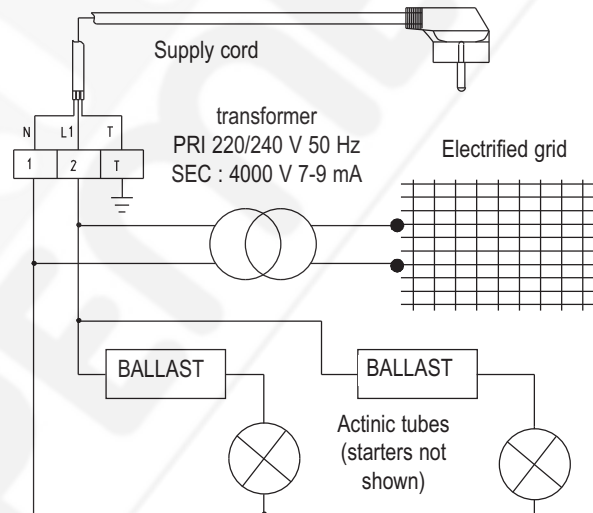

WIRING DIAGRAM model 806 947

INSECT KILLERS LIME

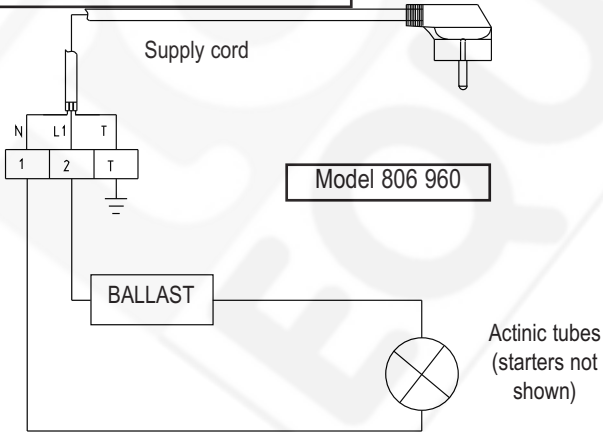

Model 806 960

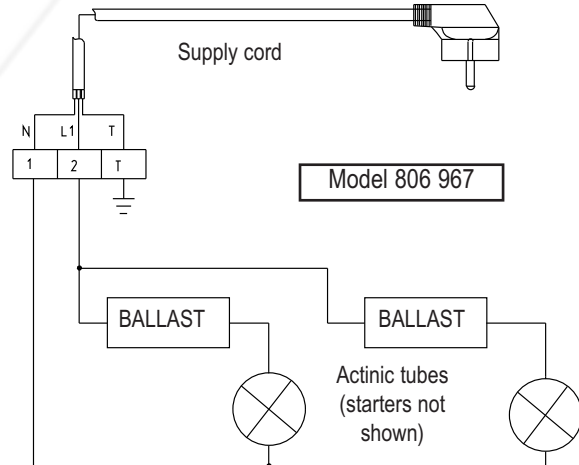

Model 806 967

RISKS WHEN IN USE

Never use the insect killers without the safety grids.

SPARE PARTS

• Ballast 18 W - 230 V	: 229 810	• Starter for all models except 806 943 and 806 945	: 262 100
• Ballast 30 W - 230 V	: 229 811	• Starter for models 806 943 and 806 945	: 262 099
• Ballast 36 W - 230 V	: 229 812	• Transformer 4000 V - 9 mA	: 262 484
• Actinic tube 15 W	: 229 800	• Insect killers lime strip dim. 590 x 330 mm	: 807 080
• Actinic tube 20 W	: 229 801		
• Actinic tube 40 W	: 229 802		

MAINTENANCE AND CLEANING

MAINTENANCE

- Do not forget to empty the retrieval container on a daily basis (electric insect killers)
- Do not forget to change the insect lime strip on a regular basis (electric insect lime)

CLEANING

Before cleaning, you must check that the insect killers is disconnected, i.e. unplugged, to avoid any risk of electrocution.

- The insect killers must be cleaned regularly using standard cleaning products in compliance with hygiene standards, but not with abrasive products. Avoid chlorinated products (bleach for example) and rinse thoroughly after cleaning. It is recommended that you wear gloves during cleaning operations.

WORKING LIFE

**YOU MUST CHANGE THE LIGHTING TUBES EVERY YEAR.
After this time limit, the tubes will still work but lose most of their attractive power.**

SERVICING

WARNING :

Servicing must be carried out by an authorized person.

Before any servicing operation, you must make sure that the insect killers is disconnected, i.e. unplugged, to avoid any risk of electrocution.

If the supply cord is damaged, it must be replaced by the manufacturer, its after-sales service or by an authorized person, in order to avoid any type of danger.

To access the neon light or the electrocution grid, you must take off one of the safety grids by removing the 4 screws that secure it.

To access the ballast, the tie-point block or the transformer, just remove the top cover which is also secured by 4 screws.