



F900 SERIES

User, installation and servicing instructions

NEUTRAL UNIT

N940, N940D, N940DR, N940T, N941, N960, N960D,
N960DR, N961, N910, N920

Read these instructions before use

DATE PURCHASED:

MODEL NUMBER:

SERIAL NUMBER:

DEALER:

SERVICE PROVIDER:

T100893

REV. 6

Dear Customer,
Thank you for choosing Falcon Foodservice Equipment.

This manual can be downloaded from www.falconfoodservice.com or scan here.



IMPORTANT: Please keep this manual for future reference.

Falcon Foodservice Equipment

HEAD OFFICE

Wallace View, Hillfoots Road, Stirling. FK9 5PY. Scotland.



WEEE Directive Registration No. WEEE/DC0059TT/PRO

At end of appliance life, dispose of appliance and any replacement parts in a safe manner, via a licensed waste handler. Appliances are designed to be dismantled easily and recycling of all material is encouraged whenever practicable.

SYMBOLS



• SPANNER



• SCREWDRIVER



• COOKING OIL



• GREASE

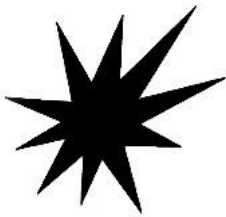

• SPARK IGNITION



• FLAME



• WARNING



• VIEWPORT



• ALLEN KEY



• IGNITER





- **These instructions are only valid if the country code appears on the appliance. If the code does not appear on the appliance, refer to the technical instructions for adapting the appliance to the conditions for use in that country.**
- **Installation must meet national or local regulations. Attention must be paid to: safety (installation & use) regulations, health and safety at work act, local and national building regulations, fire precautions act.**
- **To prevent shocks, all appliances must be earthed.**
- **This appliance has been CE-marked on the basis of compliance with the Low Voltage and EMC Directives for the voltages stated on the data plate**
- **This equipment is for professional use only and must be used by qualified persons.**
- **The installer must instruct the responsible person(s) of the correct operation and maintenance of the appliance.**
- **Only competent persons are allowed to service this appliance.**
- **Unless otherwise stated, parts which have been protected by the manufacturer must not be adjusted by the installer.**
- **Take care when moving an appliance fitted with castors.**
- **The appliance must be serviced regularly by a qualified person. Service intervals should be agreed with the service provider.**
- **Check that no damage has occurred to the appliance, power cable, or plug during transit. If damage has occurred, do not use this appliance.**
- **Installation, periodic testing, repair and fixed wiring connections should only be undertaken by a competent electrician.**
- **Ensure power cable is routed free from the appliance to avoid damage.**
- **We recommend supplementary electrical protection with the use of a residual current device (RCD)**
- **The appliance has been designed and approved to use Falcon Kick plates, non Falcon kick plates could potentially adversely affect the performance of the appliance by restricting the air to the appliance.**

CONTENTS

1	APPLIANCE INFORMATION.....	6
2	SPECIFICATION	7
3	DIMENSIONS / CONNECTION LOCATIONS	8
4	INSTALLATION	11
4.1	ASSEMBLY	11
4.2	EQUIPOTENTIAL CONNECTION	11
4.3	SUITING	11
5	SPARE PARTS.....	14
6	SERVICING INFORMATION	14

1 APPLIANCE INFORMATION

This appliance has been CE-marked on the basis of compliance with the relevant EU directives for the heat inputs, gas pressures and voltages stated on the data plate.

Falcon Foodservice Equipment  P.I.N STD. EN 

A Ser No. **B** MODEL **C** TYPE I.P.

	AT, CH, CY, CZ, DK, EE, FI, GR, IT, LT, NO, RO, SE, SI, SK	BE, CH, CY, CZ, ES, FR, GB, GR, IE, IT, LT, PT, SI, SK	DE, PL, RO	AT, BE, CH, CY, CZ, DE, DK, EE, FR, GB, GR, HU, IT, LT, NL, PL, RO, SE, SI, SK	CH, CY, CZ, ES, GB, GR, IE, IT, LT, PT, SI, SK	DE, PL, RO	AT, CH, CY, CZ, DK, EE, ES, FI, FR, GB, GR, IE, IT, LT, LV, NL, NO, PT, RO, SE, SI, SK	BE, CY, ES, FI, FR, GB, GR, IE, PT	BE, CH, CZ, ES, FR, GB, GR, IE, IT, LT, NL, PL, PT, SI, SK
D Cat.	I12H3B/P	I3+	I12E3B/P	I3B/P	I12H3+	I2E	I2H	I3B	I3P
E p mbar	20;30;50	28-30/37	20;30;50	30;50	20;28-30/37	20	20	28-30	37

F GAS TYPE	G20	G30	G31
G GAS RATE	m ³ /h	kg/h	kg/h
H Σ Qn	KW	KW	kW

I EL. Hz

J Σ kW kW **K** kHz

L L1 A L2 A L3 A

A - Serial No

B - Model No

C - Flue Type

D - Gas Category

E - Gas Pressure

F - Gas Type

G - Gas Rate

H - Total Heat Input

I - Electrical Rating

J - Total Electrical Power

K - Magnetic Field Frequency

L - Electrical Phase Loading

2 SPECIFICATION

Model	Description
N940	400mm unit
N940D	400mm unit with left hand door
N940DR	400mm unit with right hand door
N940T	400mm worktop unit
N941	400mm unit with side guides
N960	600mm unit
N960D	600mm unit with left hand door
N960DR	600mm unit with right hand door
N961	600mm unit with side guides
N910	100mm Infill unit
N920	200mm Infill unit

3 DIMENSIONS / CONNECTION LOCATIONS

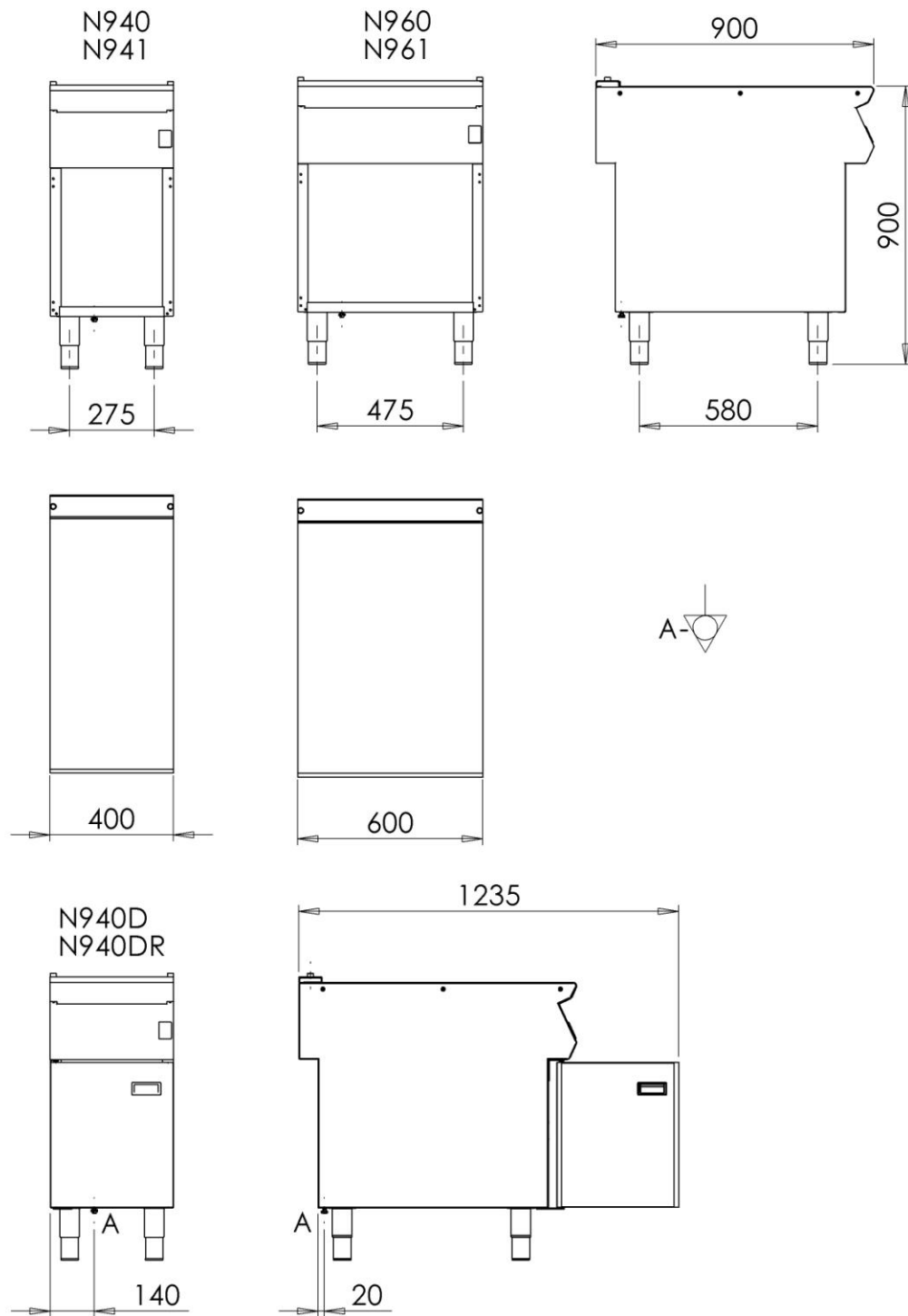

N910



N920



100

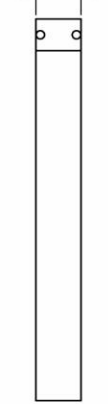

200

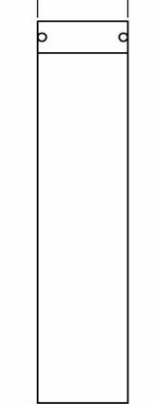

900

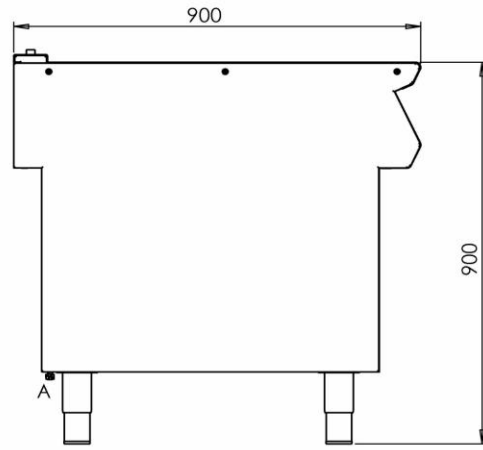

900



N940T

400

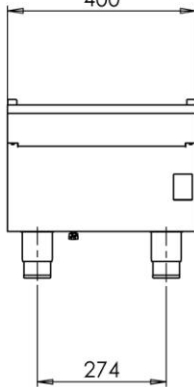

274

900

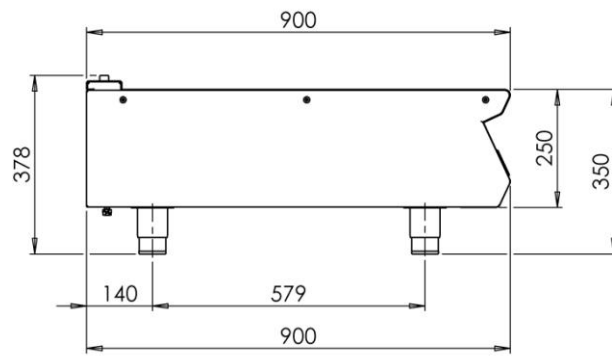

378

140

579

900

250

350



N960D/DR

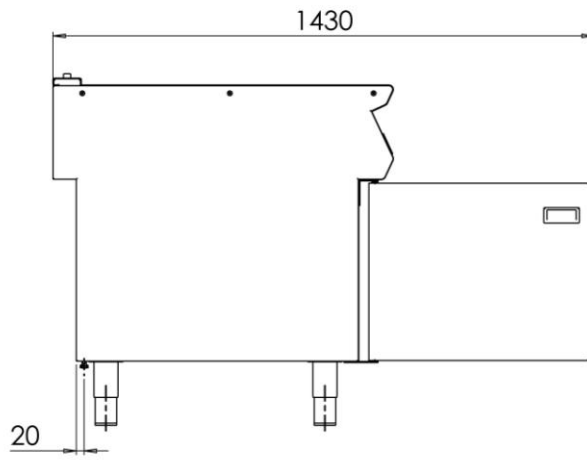
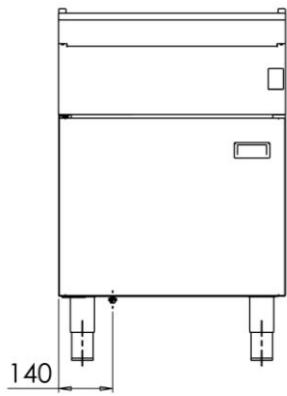

4 INSTALLATION

4.1 ASSEMBLY

4.1.1 Position appliance and level using feet or castor adjusters as shown below.

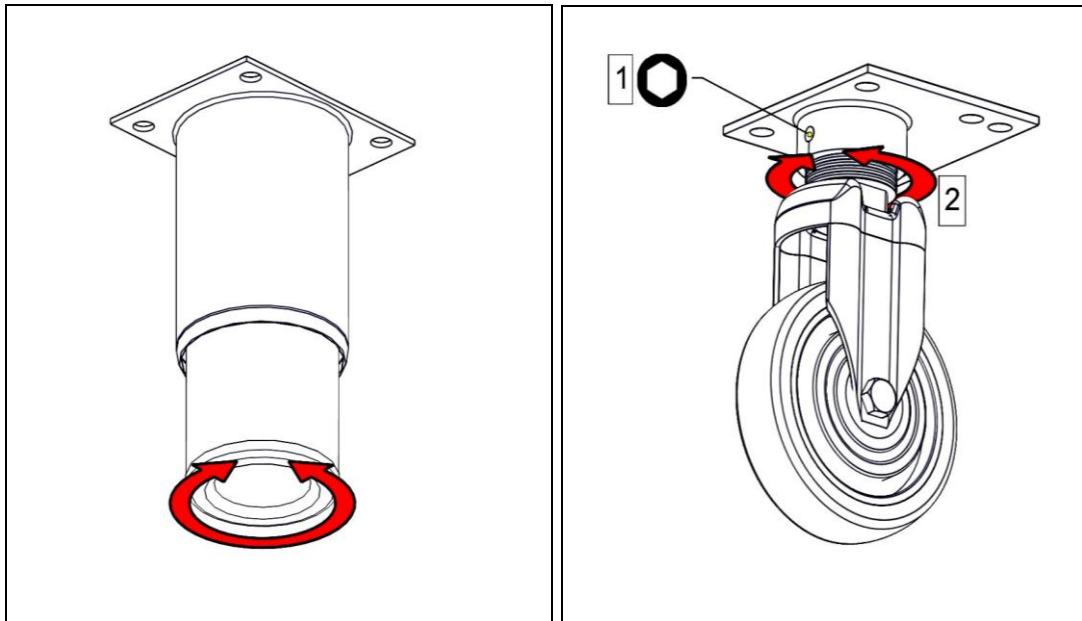

4.2 EQUIPOTENTIAL CONNECTION

4.2.1 This appliance is also provided with a terminal for connection of an external equipotential conductor. This terminal is in effective electrical contact with all fixed exposed metal parts of the appliance, and shall allow the connection of conductor having a nominal cross-section area of up to 10mm². It is located at the rear of the unit and identified by the following label and must only be used for bonding purposes.

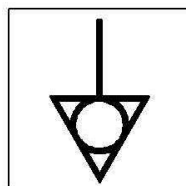

4.3 SUITING

“Patent pending, application no. GB 1511389.7”

- 4.3.1 Before leveling and suiting units ensure the units are fully built, including all accessories and castings.
- 4.3.2 Undo the 4 fixing screws on the control panel and remove.
- 4.3.3 Remove the hob rear infill and replace with rear suiting plate and fixings.

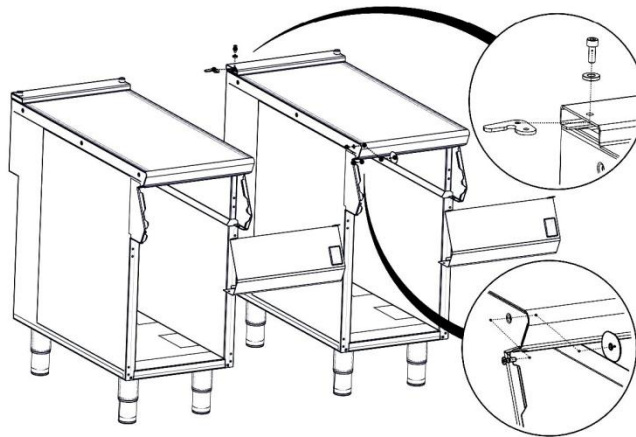

- 4.3.4 Remove the front side panel countersunk screw and suiting plate.

NOTE: The DLS system is designed to give a quick and easy suiting solution. If you require an improved seal between appliances we recommend you use, a food grade, high temperature silicon sealant. This can be supplied by Falcon part no – 523400021

- 4.3.5 Run a bead of silicon 5 mm from profile edge as highlighted below.

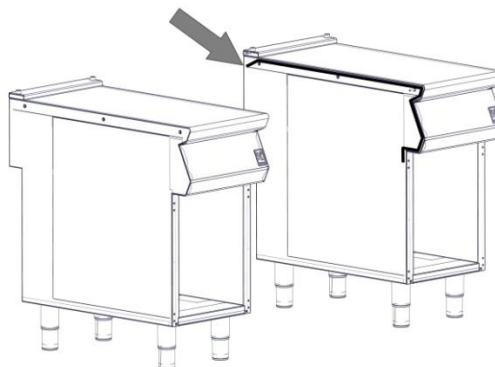

- 4.3.6 Slide suited units into position.

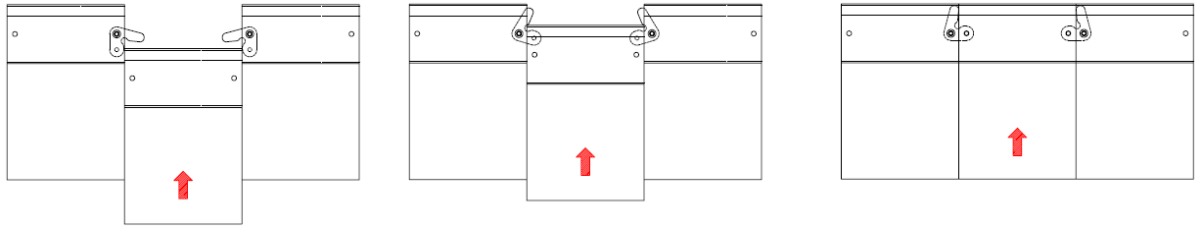

4.3.7 Right hand unit: Screw the M5 x 40 screw (supplied in the kit) into one of the suiting plates as shown and then insert through the front fixing holes of both units.

4.3.8 (B) Left hand unit: Slide the penny and lock washer on to the screw and secure using the M5 nut.

4.3.9 (C) Remove the front bolts from feet, insert base tie plate and secure the bolts back into position.

4.3.10 (D) Replace fixings on the rear hob and tighten screw caps into position.

4.3.11 Replace control panel.

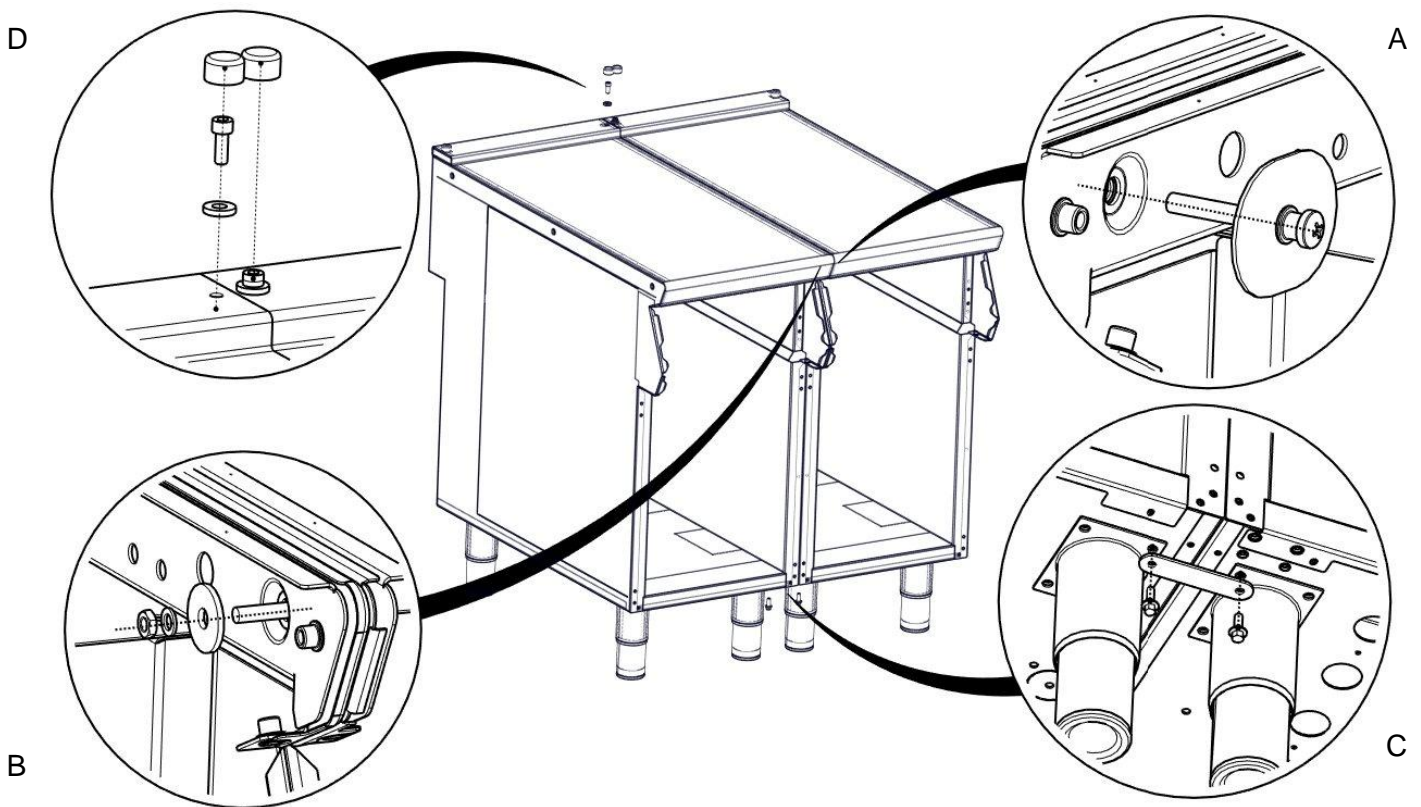

5 SPARE PARTS

F900 SCREW CAP KIT	533550009
NEUTRAL UNIT LH HINGE KIT	533810001
400 LH DOOR ASSY	533810000
MAGNET CATCH ASSY	533810003
ADJUSTABLE LEG 150MM	535480067
SWIVEL CASTOR SET OF 2	535400222
FIXED CASTOR SET OF 2	530964340
ST/ST ADJUSTABLE FEET	535150025
NEUTRAL UNIT RH HINGE KIT	533810004
400 RH DOOR ASSY	533810005
600 LH DOOR ASSY	533910000
600 RH DOOR ASSY	533910001

When ordering spares, quote the following:

Model Number

Serial number

This information will be found on data plate attached to the appliance. (see 1.0)

Visit our website for further spares information.

6 SERVICING INFORMATION

It is recommended to have a maintenance contract with a local service provider.

SERVICELINE CONTACT:

(UK only)

Phone: +441438 363 000

Warranty Policy Shortlist

For our warranty policy please go to www.falconfoodservice.com