



Item: _____
 Quantity: _____
 Project: _____
 Approval: _____
 Date: _____

Induction Green Heat
 Garland Induction Counter Wok 3.5kW, 5.0kW and 8.0kW

Induction Green Heat

Garland Induction Counter Wok 3.5, 5.0 and 8.0 kW

Models:

- GI-SH/WO 3500
 GI-SH/WO 5000
 GI-SH/WO 8000



Induction Benefits:

- Energy Efficient
- Fast Heat
- Easy To Clean
- No Pan, No Heat.
- Cool Operations
- Boil Dry Protection

Standard Features:

- Compact table top design with stainless steel body and recessed ceramic bowl to accept wok pan
- Sloped, easy to see front panel with adjustable control
- Integral cooling rear fan with protective deflectors
- Removable, reusable easy to clean air intake filter
- 6' (1829mm) cord and plug supplied
- "Flat Design", compact high performance electronics
- Instant energy transmission to the pan
- Available in 3.5 kW, 5.0 kW and 8.0 kW
- Thermostatically controlled overheat sensor shuts the unit off to prevent damage from pans cooking dry
- Induction technology transfers heat to the pan, not to the surrounding air
- Induction coil surrounds ceramic bowl
- Innovated new technology for pan detection; RTCS (Real Time Temperature Control System) is an internal control software development matching speed, capability and performance
- Electronic output limitation continually monitors the energy transfer to the pan, helping to ensure the most efficient energy transfer possible

Specifications:

Shall be a Garland Induction Unit model GI-SH/WO 3500 with a total kW rating of 3.5 kW, model GI-SH/WO 5000 with at total kW rating of 5.0 kW, or model GI-SH/WO 8000 with at total kW rating of 8.0 kW. Built with a robust stainless steel casting with a recessed ceramic bowl to accept induction ready wok pan. Compact powerful electronic system for years of service. Overheat sensor helps prevent damage of the unit if pan is run dry. Easy to operate, 1-12 scale, rotary switch. Unit comes in 208V or 240V (specify at time of order) with cord and plug for North America, other voltages available.

Note: Induction cooking requires "Induction Ready" pans to operate. Garland recommends that the wok pans used

be the correct contour to the ceran glass. To reduce permature failures such as overheating, wok pans should not touch the glass but only sit onto upper case flange. Garland offers a number of wok induction pans.



Intertek **Intertek**
 CE models comply with the latest European Norms:
 EN 60335-1, EN 60335-2-36, EN 62233 (EMC/EMV)
 North American models:
 ETL listed in compliance with
 UL 197, CSA C22.2 No.109, NSF-4
 Complies with FCC part 18, ICES-001

Garland Commercial Ranges Ltd.
 1177 Kamato Road,
 Mississauga, Ontario
 L4W 1X4 CANADA

General Inquiries 1-905-624-0260
 USA Sales, Parts and Service 1-800-424-2411
 Canadian Sales 1-888-442-7526
 Canada or USA Parts/Service 1-800-427-6668



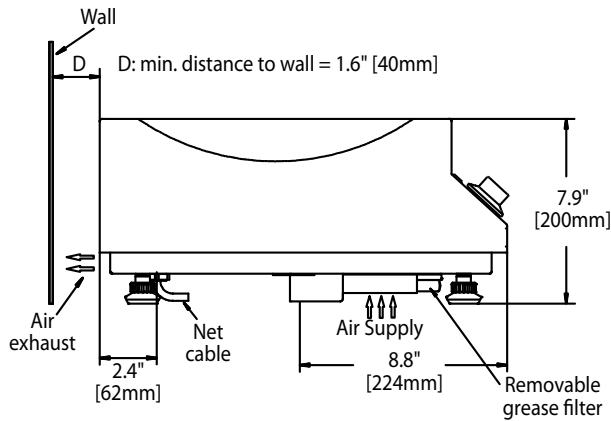
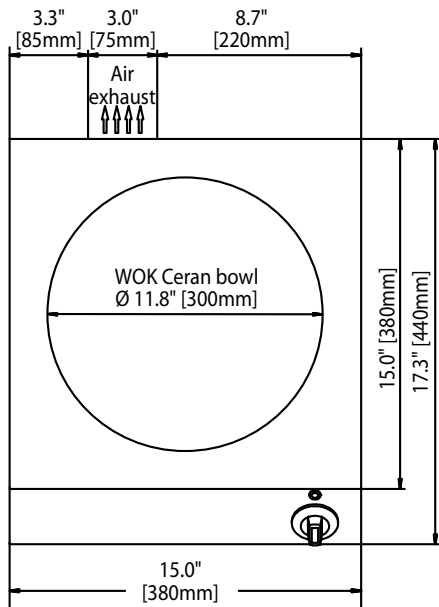

Electrical Loading				
Model	Watts	208/60/1	240/60/1	230/50/1
GI-SH/VO 3500	3500	16 amp	14 amp	15 amp

Electrical Loading				
Model	Watts	208/60/3	400/50/3	440/50/3
GI-SH/VO 5000	5000	14 amp	8 amp	7 amp

Electrical Loading		
Model	Watts	400/50/3
GI-SH/VO 8000	8000	12 amp

Garland/U.S. Range products are not approved or authorized for home or residential use, but are intended for commercial applications only. Garland / U.S. Range will not provide service, warranty, maintenance or support of any kind other than in commercial applications.

Options & Accessories

- High quality induction stainless steel wok pan; 5.2 liter and 9.5 liter are available.
- Extra replacement air intake filter stock SKU# 71000012 (available as a replacement part through your local authorized parts & service depot)

Plug Configurations		
Model	Electrical Characteristics	Plug
GI-SH/VO 3500	208V/60Hz/1Φ 240V/60Hz/1Φ	 NEMA 6-20P
	230V/50Hz/1Φ	 EU1-16P
GI-SH/VO 5000	208V/60Hz/3Φ	 NEMA 15-20P
		 NEMA L15-20P
	400V/50Hz/3Φ	 EU 5-Pole
	440V/50Hz/3Φ	Plug not included
GI-SH/VO 8000	400V/50Hz/3Φ	 EU 5-Pole

Form# GI-SH/VO 3500/5000/8000 (04/21/15)