

SKIPIO

by Experts, for Experts

Singapore SKIPIO

ADD: 20 Sin Ming Lane, #05-55 Singapore 573968
TEL: +65 - 9338 - 6993
WEBSITE: www.skipiosg.com

Australia SKIPIO

ADD: 218 Woodpark Road Smithfield NSW 2164
WEBSITE: www.skipio.com.au

SKIPIO QINGDAO Factory

ADD: west of Zhushan Road, No.297 North of Haibin 7 Road,
Jiaonan Coastal Industrial Park, Qingdao, China
WEBSITE: www.skipiochina.com

SKIPIO KOREA Factory

ADD: 61, Gyeonggigwagide-ro, Siheung-si, Gyeonggi-do, Republic
of Korea
WEBSITE: www.skipiokorea.com

WWW.SKIPIOSG.COM



*The specifications of this catalog may change without any advance notice due to meet the demand of customers.

SKIPIO

PRODUCT CATALOG 2018



SKIPIO

by Experts, for Experts

WWW.SKIPIOSG.COM

WARRANTY

2
YEAR



HIGH BAKERY CASE



RECTANGLE BAKERY CASE



ROUND BAKERY CASE



COMBI SHOWCASE



REACH-IN



REACH-IN [BUN PAN]



REACH-IN [GLASS DOOR]



UNDER COUNTER



UNDER COUNTER [GLASS DOOR]



HIGH OPEN CASE



OPEN CASE



OPEN DISPLAY CASE



OPEN ROUND CASE



UNDER COUNTER [DRAWER]



SALAD PREP TABLE [BUFFET]



SALAD PREP TABLE [HOOD LID]



ICE MAKER



OPEN JUICE CASE



SANDWICH CASE



CHOCOLATE CASE



GELATO CASE



CHEF BASE



BACK MOUNTED UNDER COUNTER



BAR LINE



MOBILE CART



BLAST FREEZER



TABLE GELATO CASE



ICE CREAM DIPPING CABINET



BACK BAR



GLASS DOOR MERCHANDISER



DOUGH CHILLER



DOUGH CONDITIONER



CONVECTION OVEN



DECK OVEN



MICROWAVE OVEN



DISH WASHER

GLOBAL NETWORK

SKIPIO is an international commercial refrigeration manufacturer with its Korean headquarter in Seoul and factory fully operated in Si Hwa. We SKIPIO have long-term global experience and abundant knowledge in sales, manufacturing and technology for refrigeration. Our expertise lies in the field of commercial refrigerated cabinets, bakery showcases, ice makers, blast chillers, custom-made products, and so on.

We produce 30,000 units per year in these factories with the most cutting-edge facilities and manufacturing equipment such as NCTs, individual foaming jigs, and automatic bending machines along with mass production lines. With such high-tech-equipment, we inspect and assess every single product thoroughly in our performance test laboratory and Institute of Technology. SKIPIO manufactures products with a high level of efficiency and quality, and exports its products to five continents including 67 countries in Europe, Asia, America and so forth. we have built our reputation and trust in the global markets for years through our quality products, product performance and satisfactory after-sales service.

SKIPIO

by Experts, for Experts



SKIPIO FACTORY



CHINA FACTORY

ADD : west of Zhushan Road, No.297
North of Haibin 7 Road, Jiaonan Coastal Industrial Park, Qingdao, China.



KOREA FACTORY SYSTEM

ADD : 61, Gyeonggwagide-ro, Siheung-si, Gyeonggi-do, Republic of Korea.



KOREA
ADD: B-511/512, 167, Songpa-daero, Songpa-gu, Seoul, Republic of Korea
TEL: +82 - 02 - 3473 - 9725 / 9726
FAX: +82 - 02 - 3473 - 9727



AUSTRALIA
ADD: 218 Woodpark Road Smithfield NSW 2164
TEL: +61 - 02 - 8798 - 5061 / 5283 / 5581
FAX: +61 - 02 - 8798 - 5707



SINGAPORE
ADD: 20 Sin Ming Lane, #05-55 Singapore 573968
TEL: +65 - 9338 - 6993

FACTORY LINE



SKIPIO EXHIBITION



PRODUCT FEATURES

▶ BAKERY CASE-HIGH

• **COLOR OPTION**
Comes in 10 different colors of sus / mirror.



• **LED LAMP**
Enhance the display effect, and reduces unnecessary energy consumption.



• **LED LIGHT PANEL**



• **DRAIN WATER EVAPORATION SYSTEM**



• **HIGH QUALITY GLASS**
Optimisation of display effect & Use of tempered glass user safety.



• **SIMPLE STRUCTURE**
for easy maintenance.



• **AIR FLOW GRILLE**



• **DIGITAL TEMPERATURE CONTROL SYSTEM**
Enables precise control of temperature, power and light.

▶ BAKERY CASE - RECTANGLE

• **HIGH QUALITY GLASS**
Optimisation of display effect & Use of tempered glass user safety.



• **LED 灯 (LED LAMP)**
Enhance the display effect, and reduces unnecessary energy consumption.



• **LED LIGHT PANEL**



• **COLOR OPTION**
Comes in 10 different colors of sus / mirror.



• **TEMPERATURE & HUMIDITY MONITOR**
Possible to confirm temperature & humidity inside the bakery case.



• **DRAIN WATER EVAPORATION SYSTEM**

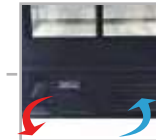

• **HIGH EFFICIENCY AIR VENTILATION**
High efficiency of air ventilation for long life time.



• **DIGITAL TEMPERATURE CONTROL SYSTEM**
Enables precise control of temperature, power and light.

▶ OPEN CASE

• **COLOR OPTION**
Comes in 10 different colors of sus / mirror.



• **LED LAMP**
Enhance the display effect, and reduces unnecessary energy consumption.



• **A WIDER TEMPERATURE RANGE, 5~10°C**



• **AIR FLOW GRILLE**

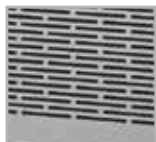

• **ENERGY SAVING NIGHT CURTAIN STANDARD**



• **IMPROVED AIR FLOW**
Evenly distributes cold air on all levels.



• **WARM BLOWN AIR SYSTEM**
Warm air is blown over the exterior of both sides to minimise condensation.



• **DIGITAL TEMPERATURE CONTROL SYSTEM**
Enables precise control of temperature, power and light.

▶ CHOCOLATE CASE

• **HIGH QUALITY GLASS**
Optimisation of display effect & Use of tempered glass user safety.



• **SMALL LED LIGHTING**



• **LED LIGHT PANEL**



• **COLOR OPTION**
Comes in 10 different colors of sus / mirror / marble.



• **SLIDING DRAWER TYPE**



• **REAR ACCESS REFRIGERATED STORAGE**



• **DRAIN WATER EVAPORATION SYSTEM**



• **DIGITAL TEMPERATURE CONTROL SYSTEM**
Enables precise control of temperature, power and light.



► REACH-IN

- **CONDENSER EASY CLEANING**
- **SHELVES**
- **DOOR HANDLE**
Easy grip recessed door handles.
- **SELF CLOSING AND STAY OPEN DOOR**



- **DIGITAL CONTROL SYSTEM**
- **DRAIN WATER EVAPORATION SYSTEM**
- **LED LAMP**
Enhance the display effect, and reduces unnecessary energy consumption.
- **QUALITY IMPORTED COMP**
Enable highly efficient and operation.

► BLAST FREEZER

- **DOOR HANDLE**
Easy grip recessed door handles.
- **CRYOGENIC POWER COOLING CHILLING**
retain original flavour & shape of ingredients and provide more hygienic and faster food.
- **QUALITY IMPORTED COMP**
Enable highly efficient and operation.
- **DIGITAL CONTROL SYSTEM**
The temperature of the precise identification system.



- Shortens cooking & serving time by cryogenic cooling technology.
- Possible to purchase grocery more efficiently.
- Possible to prepare a variety of hygienic and safe menu.

Mode	Core temperature of the food
Soft Chilling +3°	From 90°C to 3°C within 90 minutes
Hard Chilling +3° HARD	From 90°C to -20°C and stay at 3°C within 90 minutes
Shock Freezing -18°	From 90°C to -18°C within 240 minutes

► UNDER COUNTER

- **FRONT BREATHING HOLE**
- **QUALITY IMPORTED COMP**
Enable highly efficient and operation.
- **CONDENSER EASY CLEANING**



- **DIGITAL CONTROL SYSTEM**
- **DOOR HANDLE**
Easy grip recessed door handles.
- **SHELVES**
- **LED LAMP**
Enhance the display effect, and reduces unnecessary energy consumption.

► ICE MAKER

- **SELF CONTAINED ICE BIN**
Self-contained ice machines (SIM-50A/75A/100A) can be installed under the counter.
- **ERGONOMIC DESIGN**
Ergonomic design with sliding doors for better use of space.
- **FRONT AIR FILTER**
Easy access to front air filter for cleaning.
- **HIGH EFFICIENCY AIR VENTILATION**
High efficiency of air ventilation for long life time.



- **FRONT DIGITAL CONTROLLER**
Possibility of confirming or regulating products from exterior.
- **INNOVATIVE SELF CLEANING**
- **AUTO NOTIFICATION FOR AIR CLEANING CYCLE**
- **SIMPLE STRUCTURE**
Easier maintenance.
- **LED LAMP**
Enhance the display effect, and reduces unnecessary energy consumption.



BAKERY CASE

HIGH BAKERY CASE
RECTANGLE BAKERY CASE
ROUND BAKERY CASE

SKIPIO

BAKERY CASE HIGH

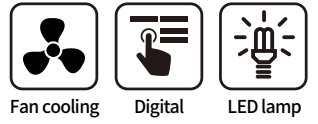

SBH1500-4FD

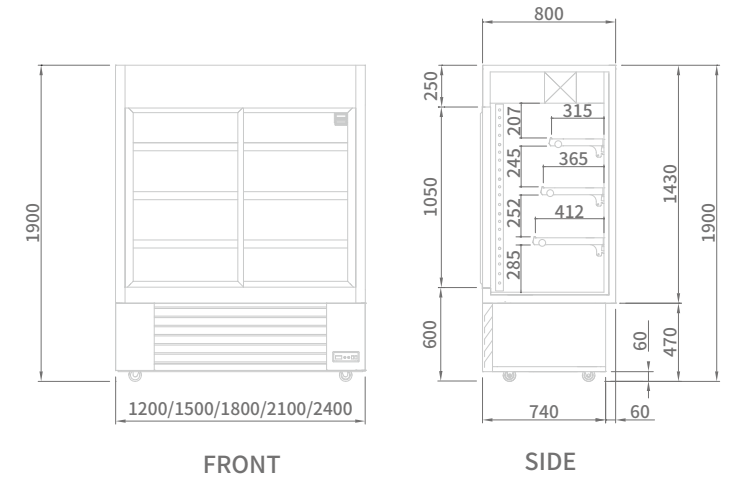

SBH1200-4FD

SBH1800-4FD

SBH2100-4FD

SBH2400-4FD



MODEL	SBH1200-4FD	SBH1500-4FD	SBH1800-4FD	SBH2100-4FD	SBH2400-4FD
Classification	Refrigerator				
Cabinet dimension (WxDxH mm)	1200 / 1500 / 1800 / 2100 / 2400 x 800 x 1900				
Capacity (ℓ)	510	633	760	886	1013
Inner Temperature (°C)	3 ~ 8				
Refrigerant	R-134a	R-134a	R-404a	R-404a	R-404a
Insulation Type	Polyurethane / Cyclopentane + CFC Free				
Amps (A)	3	3.5	4	4.5	4.5
Voltage (V/Hz/Ph)	220 / 50 / 1				
Weight (Kg)	250	300	360	420	470
Door type	Sliding door				
# of doors	2	2	2	2	2
Compressor (HP)	1/3	1/3	1	1	1
# of Shelves	3	3	3	3	3

DISPLAY PRODUCT

REACH-IN

UNDER COUNTER

ICE MAKER

SPECIAL MODEL

BAKING LINE

DISH WASHER

BAKERY CASE RECTANGLE

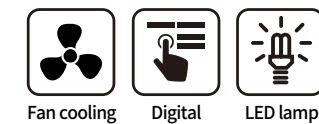

SB1500-2RD



2 Layer

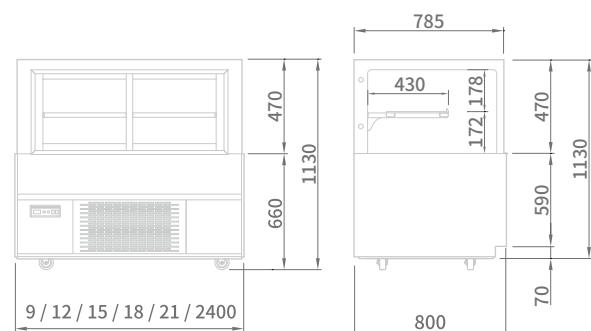

SB1500-4RD



4 Layer

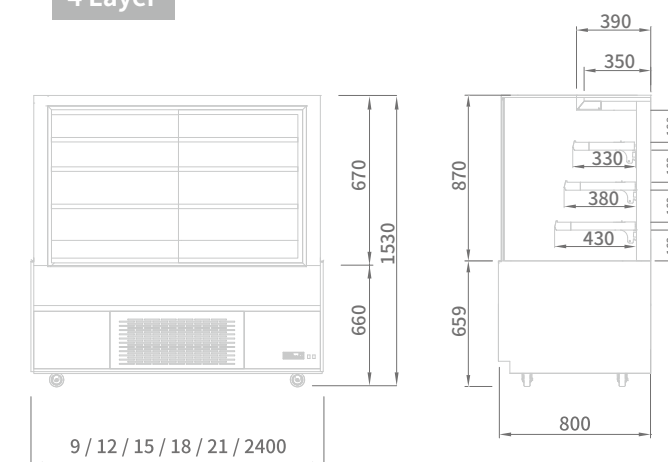

SB900-2RD

SB1200-2RD

SB1800-2RD

SB2100-2RD

SB2400-2RD



SB1500-3RD



3 Layer

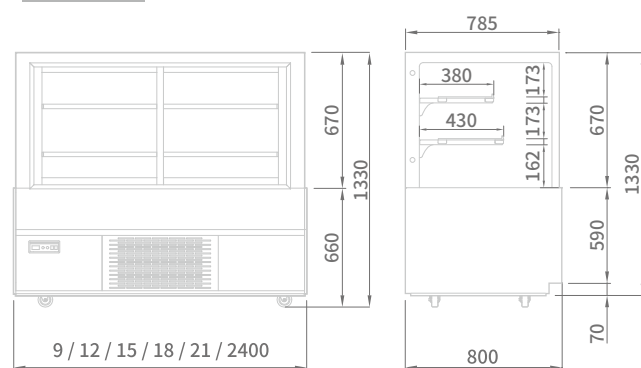

SB900-4RD

SB1200-4RD

SB1800-4RD

SB2100-4RD

SB2400-4RD



SB900-3RD

SB1200-3RD

SB1800-3RD

SB2100-3RD

SB2400-3RD



MODEL	SB900-3RD	SB1200-3RD	SB1500-3RD	SB1800-3RD	SB2100-3RD	SB2400-3RD
Classification	Refrigerator					
Cabinet dimension (WxDxH mm)	900 / 1200 / 1500 / 1800 / 2100 / 2400 x 800 x 1130 (2Layer)/1330(3Layer)/1530(4Layer)					
Capacity (ℓ)	501	669	837	1005	1173	1336
Inner Temperature (°C)	3 ~ 8					
Refrigerant	R-134a	R-134a	R-404a	R-404a	R-404a	R-404a
Insulation Type	Polyurethane / Cyclopentane + CFC Free					
Amps (A)	3.5	3.8	4	4	5	5.5
Voltage (V/Hz/Ph)	220 / 50 / 1					
Weight (Kg)	190	240	280	300	340	400
Door type	Sliding door					
# of doors	2	2	2	2	3	3
Compressor (HP)	1/3	1/3	1/2	1	1	1
# of Shelves	1 (2Layer) / 2(3Layer) / 3(4Layer)					

DISPLAY PRODUCT REACH-IN UNDER COUNTER ICE MAKER SPECIAL MODEL BAKING LINE DISH WASHER

BAKERY CASE ROUND



SBR1500-3RD

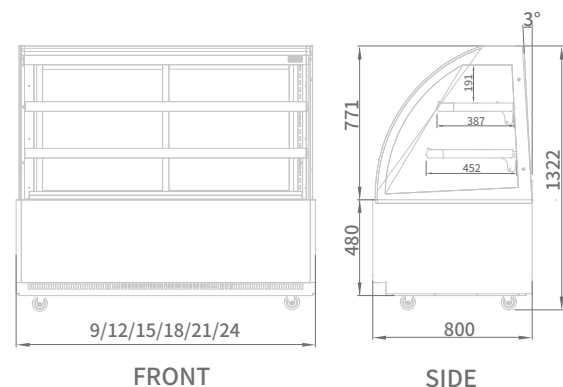

SBR900-3RD SBR1200-3RD SBR1800-3RD SBR2100-3RD SBR2400-3RD



MODEL	SBR900-3RD	SBR1200-3RD	SBR1500-3RD	SBR1800-3RD	SBR2100-3RD	SBR2400-3RD
Classification	Refrigerator					
Cabinet dimension (WxDxH mm)	900 / 1200 / 1500 / 1800 / 2100 / 2400 x 800 x 1130(2Layer)/1322(3Layer)/1530(4Layer)					
Capacity (ℓ)	501	669	837	1005	1173	1336
Inner Temperature (°C)	3 ~ 8					
Refrigerant	R-134a	R-134a	R-404a	R-404a	R-404a	R-404a
Insulation Type	Polyurethane / Cyclopentane + CFC Free					
Amps (A)	3.5	3.8	4	4	5	5.5
Voltage (V/Hz/Ph)	220 / 50 / 1					
Weight (Kg)	180	230	270	290	330	390
Door type	Sliding door					
# of doors	2	2	2	2	3	3
Compressor (HP)	1/3	1/3	1/2	1	1	1
# of Shelves	1 (2Layer) / 2(3Layer) / 3~4 (4Layer)					

SKIPIO BAKERY SHOWCASE CUSTOM MADE



DISPLAY PRODUCT

REFACH-IN

UNDER COUNTER

ICE MAKER

SPECIAL MODEL

BAKING LINE

DISH WASHER



OPTION GUIDE

1 Dimension

▶ Width

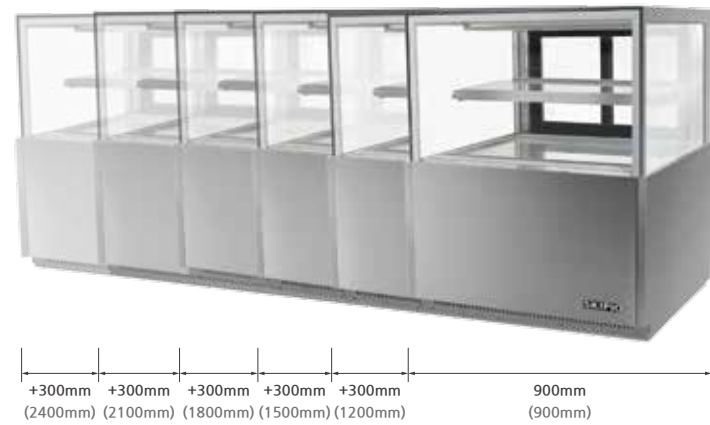

▶ Height

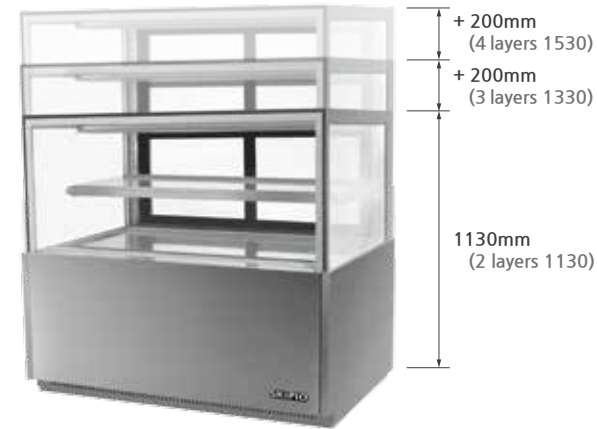

3 Exterior materials and colors

▶ Stainless steel & PCM



Stainless (SUS)

Black

White

2 Door type

▶ Rear door



▶ Front door



4 LED lamp

※ LED Options applicable (color /illumination)

▶ External

- Fluorescent Shape



- Mixed mode



▶ Color

- Warm White



- Cool White





COMBI SHOWCASE



SKIPIO

COMBI SHOWCASE

SBC-1500RD

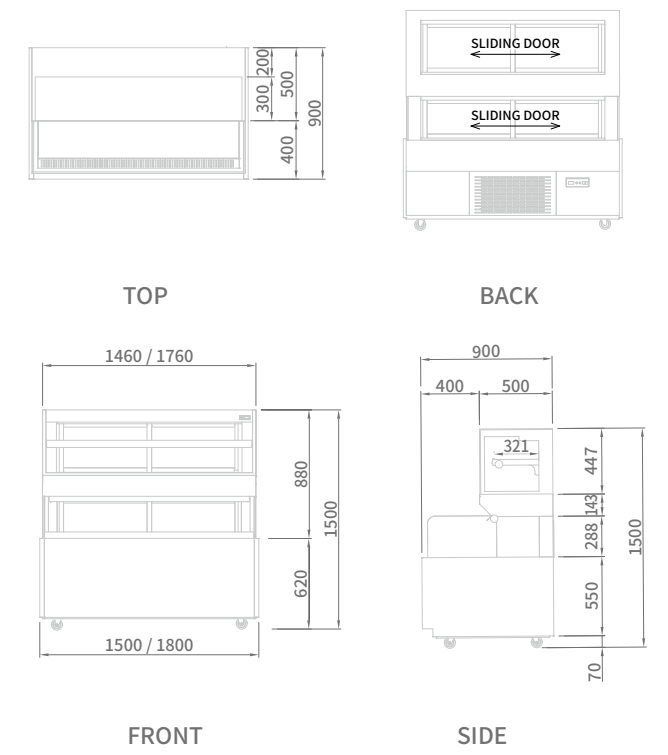
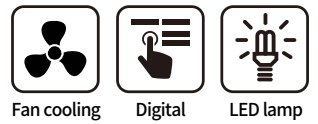

SBC-1500RD



SBC-1800RD



MODEL	SBC-1500RD	SBC-1800RD
Classification	Refrigerator	
Cabinet dimension (WxDxH mm)	1500 / 1800 x 900 x 1500	
Capacity (ℓ)	Bakery 106 / Open 260	Bakery 136 / Open 310
Inner Temperature (°C)	Bakery 3~ 8 / Open 5 ~ 10	Bakery 3 ~ 8 / Open 5 ~ 10
Refrigerant	R-404a	R-404a
Insulation Type	Polyurethane / Cyclopentane + CFC Free	
Amps (A)	6.3	7.6
Voltage (V/Hz/Ph)	220 / 50 / 1	
Weight (Kg)	300	400
Door type	Sliding door	
# of doors	4	4
Compressor (HP)	Bakery 1/2 / Open 1	Bakery 1 / Open 1
# of Shelves	1	1

DISPLAY PRODUCT REACH-IN UNDER COUNTER ICE MAKER SPECIAL MODEL BAKING LINE DISH WASHER

OPEN CASE

- HIGH OPEN CASE
- OPEN CASE
- OPEN DISPLAY CASE
- OPEN ROUND CASE
- OPEN JUICE CASE



OPEN CASE HIGH

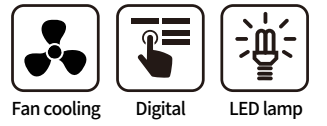

SOH-1500

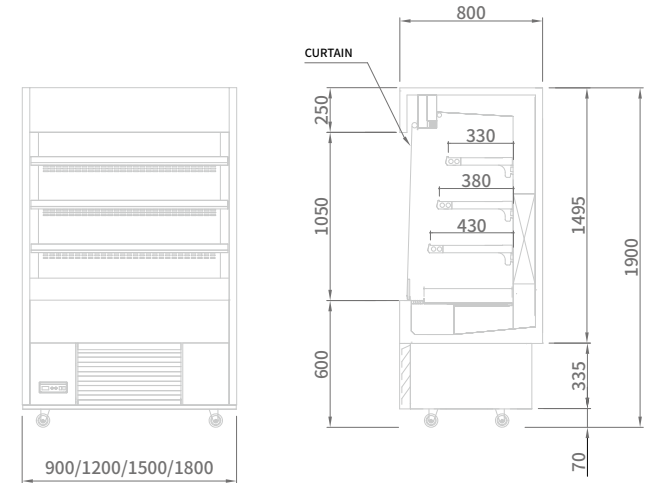

*** Notes on Use**

Open showcase must be placed where the surrounding environment is no greater than +25°C, the wind speed is no greater than 0.3 meter/sec and the humidity level is no greater than 60%.

SOH-900



SOH-1200



SOH-1800



MODEL	SOH-900	SOH-1200	SOH-1500	SOH-1800
Classification	Refrigerator			
Cabinet dimension (WxDxH mm)	900 / 1200 / 1500 / 1800 x 800 x 1900			
Capacity (ℓ)	460	547	634	700
Inner Temperature (°C)	5 ~ 10			
Refrigerant	R-404a			
Insulation Type	Polyurethane / Cyclopentane + CFC Free			
Amps (A)	3	3.5	4	4.5
Voltage (V/Hz/Ph)	220 / 50 / 1			
Weight (Kg)	180	200	260	310
Compressor (HP)	1	1	1	1+
# of Shelves	3	3	3	3

DISPLAY PRODUCT

REACH-IN

UNDER COUNTER

ICE MAKER

SPECIAL MODEL

BAKING LINE

DISH WASHER

OPEN CASE

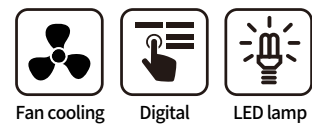

SOA-1500

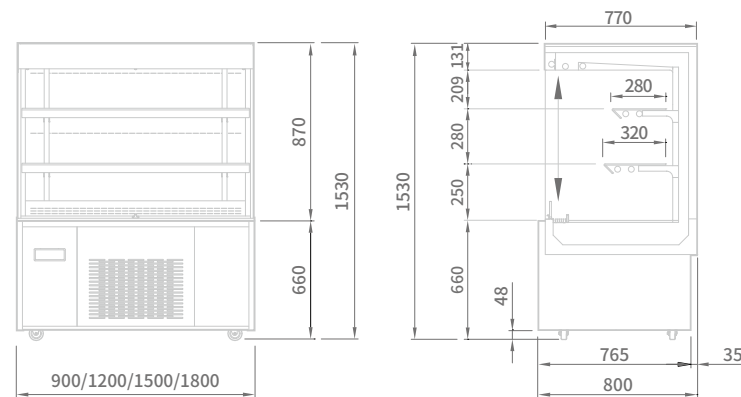

* Notes on Use

Open showcase must be placed where the surrounding environment is no greater than +25°C, the wind speed is no greater than 0.3 meter/sec and the humidity level is no greater than 60%.

SOA-900



SOA-1200



SOA-1800



MODEL	SOA-900	SOA-1200	SOA-1500	SOA-1800
Classification	Refrigerator			
Cabinet dimension (WxDxH mm)	900 / 1200 / 1500 / 1800 x 800 x 1530			
Capacity (ℓ)	430	510	600	670
Inner Temperature (°C)	5 ~ 10			
Refrigerant	R-404a			
Insulation Type	Polyurethane / Cyclopentane + CFC Free			
Amps (A)	3.8	4.5	4.9	5.5
Voltage (V/Hz/Ph)	220 / 50 / 1			
Weight (Kg)	190	240	270	310
Compressor (HP)	1	1	1	1+
# of Shelves	2	2	2	2



OPEN DISPLAY CASE

SKIPIO

OPEN DISPLAY CASE



SOM-1200

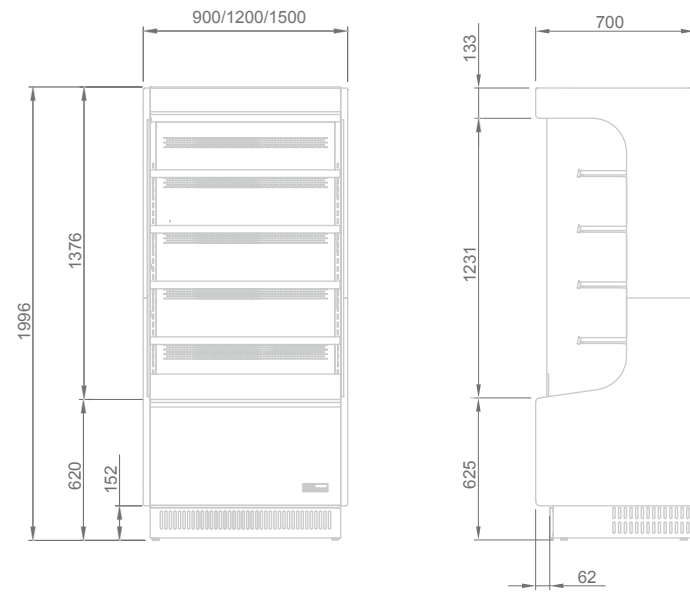

SOM-900



SOM-1500



* Notes on Use

Open showcase must be placed where the surrounding environment is no greater than +25°C, the wind speed is no greater than 0.3 meter/sec and the humidity level is no greater than 60%.

MODEL	SOM-900	SOM-1200	SOM-1500
Classification	Refrigerator		
Cabinet dimension (WxDxH mm)	900 / 1200 / 1500 x 700 x 1996		
Capacity (ℓ)	310	425	540
Inner Temperature (°C)	5 ~ 10		
Refrigerant	R-404a		
Insulation Type	Polyurethane / Cyclopentane + CFC Free		
Amps (A)	6	7	8
Voltage (V/Hz/Ph)	220 / 50 / 1		
Weight (Kg)	210	240	280
Compressor (HP)	1	1 1/4	1 1/2
# of Shelves	4	4	4

OPEN ROUND CASE

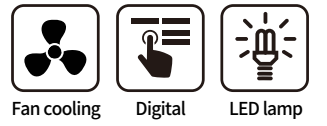

SOR-1400

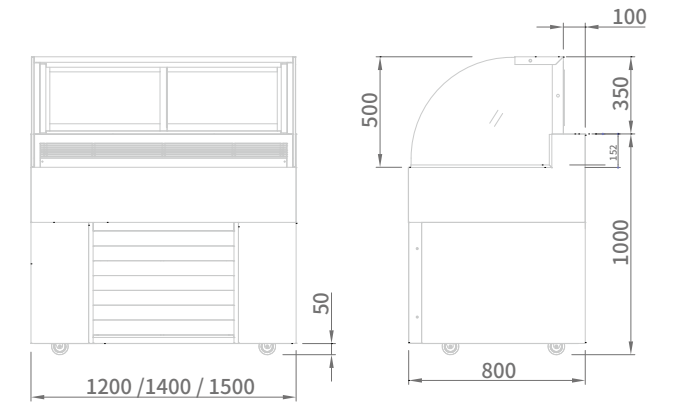

SOR-1200



SOR-1500



* Notes on Use

Open showcase must be placed where the surrounding environment is no greater than +25°C, the wind speed is no greater than 0.3 meter/sec and the humidity level is no greater than 60%.

MODEL	SOR-1200	SOR-1400	SOR-1500
Classification	Refrigerator		
Cabinet dimension (WxDxH mm)	1200 / 1400 / 1500 x 800 x 1350		
Capacity (ℓ)	155	185	200
Inner Temperature (°C)	5 ~ 10		
Refrigerant	R-404a		
Insulation Type	Polyurethane / Cyclopentane + CFC Free		
Amps (A)	5.5	6	6.5
Voltage (V/Hz/Ph)	220 / 50 / 1		
Weight (Kg)	180	195	210
Door Type	Sliding door		
# of Doors	2	2	2
Compressor (HP)	1/2	1	1

OPEN JUICE CASE

SOJ-800



Keep the drink fresh for a long time

* Notes on Use

Open showcase must be placed where the surrounding environment is no greater than +25°C, the wind speed is no greater than 0.3 meter/sec and the humidity level is no greater than 60%.

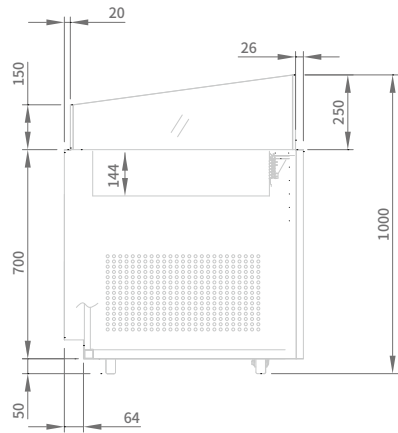
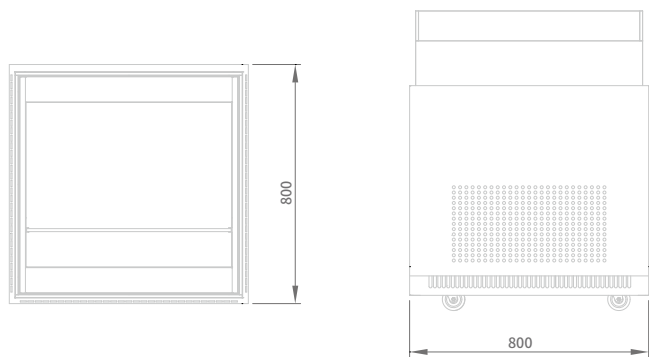

MODEL	SOJ-800
Classification	Refrigerator
Cabinet dimension (WxDxH mm)	800 x 800 x 1000
Capacity (ℓ)	74
Inner Temperature (°C)	5 ~ 10
Refrigerant	R-404a
Insulation Type	Polyurethane / Cyclopentane + CFC Free
Amps (A)	3.6
Voltage (V/Hz/Ph)	220 / 50 / 1
Weight (Kg)	140
Compressor (HP)	1/2

SKIPIO OPEN CASE REFERENCE



DISPLAY PRODUCT

REACH-IN

UNDER COUNTER

ICE MAKER

SPECIAL MODEL

BAKING LINE

DISH WASHER



SANDWICH CASE



SKIPIO

SANDWICH CASE

SOS-1500P

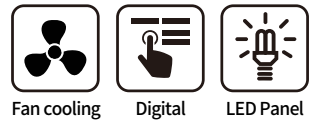

OPTIONAL - LED Panel

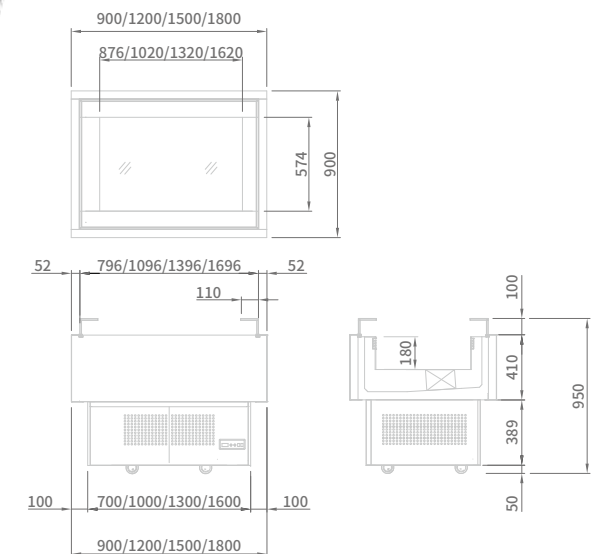

SOS-900P



SOS-1200P



SOS-1800P



MODEL	SOS-900P	SOS-1200P	SOS-1500P	SOS-1800P
Classification	Refrigerator			
Cabinet dimension (WxDxH mm)	900 / 1200 / 1500 / 1800 x 900 x 950			
Capacity (ℓ)	132	170	202	224
Inner Temperature (°C)	5 ~ 10			
Refrigerant	R-404a			
Insulation Type	Polyurethane / Cyclopentane + CFC Free			
Amps (A)	3.8	4.5	4.9	5.5
Voltage (V/Hz/Ph)	220 / 50 / 1			
Weight (Kg)	150	180	210	240
Compressor (HP)	1/2	1	1	1

DISPLAY PRODUCT

REACH-IN

UNDER COUNTER

ICE MAKER

SPECIAL MODEL

BAKING LINE

DISH WASHER

SANDWICH CASE



SOS-1500

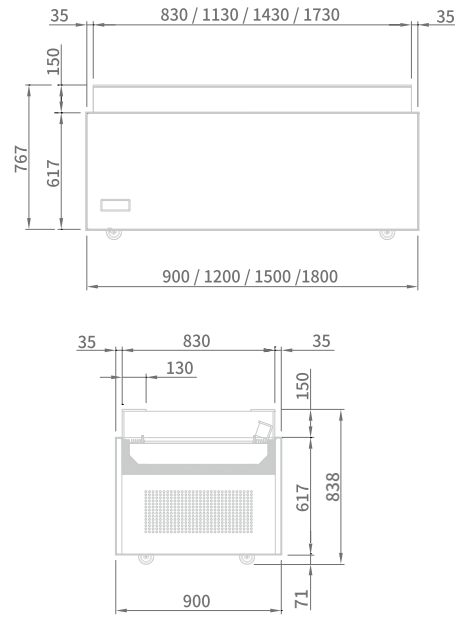

SOS-900

SOS-1200

SOS-1800



MODEL	SOS-900	SOS-1200	SOS-1500	SOS-1800
Classification	Refrigerator			
Cabinet dimension (WxDxH mm)	900 / 1200 / 1500 / 1800 x 900 x 838			
Capacity (ℓ)	112	150	182	204
Inner Temperature (°C)	5 ~ 10			
Refrigerant	R-404a			
Insulation Type	Polyurethane / Cyclopentane + CFC Free			
Amps (A)	3.8	4.5	4.9	5.5
Voltage (V/Hz/Ph)	220 / 50 / 1			
Weight (Kg)	140	170	200	230
Compressor (HP)	1/2	1	1	1

SKIPIO SANDWICH CASE REFERENCE

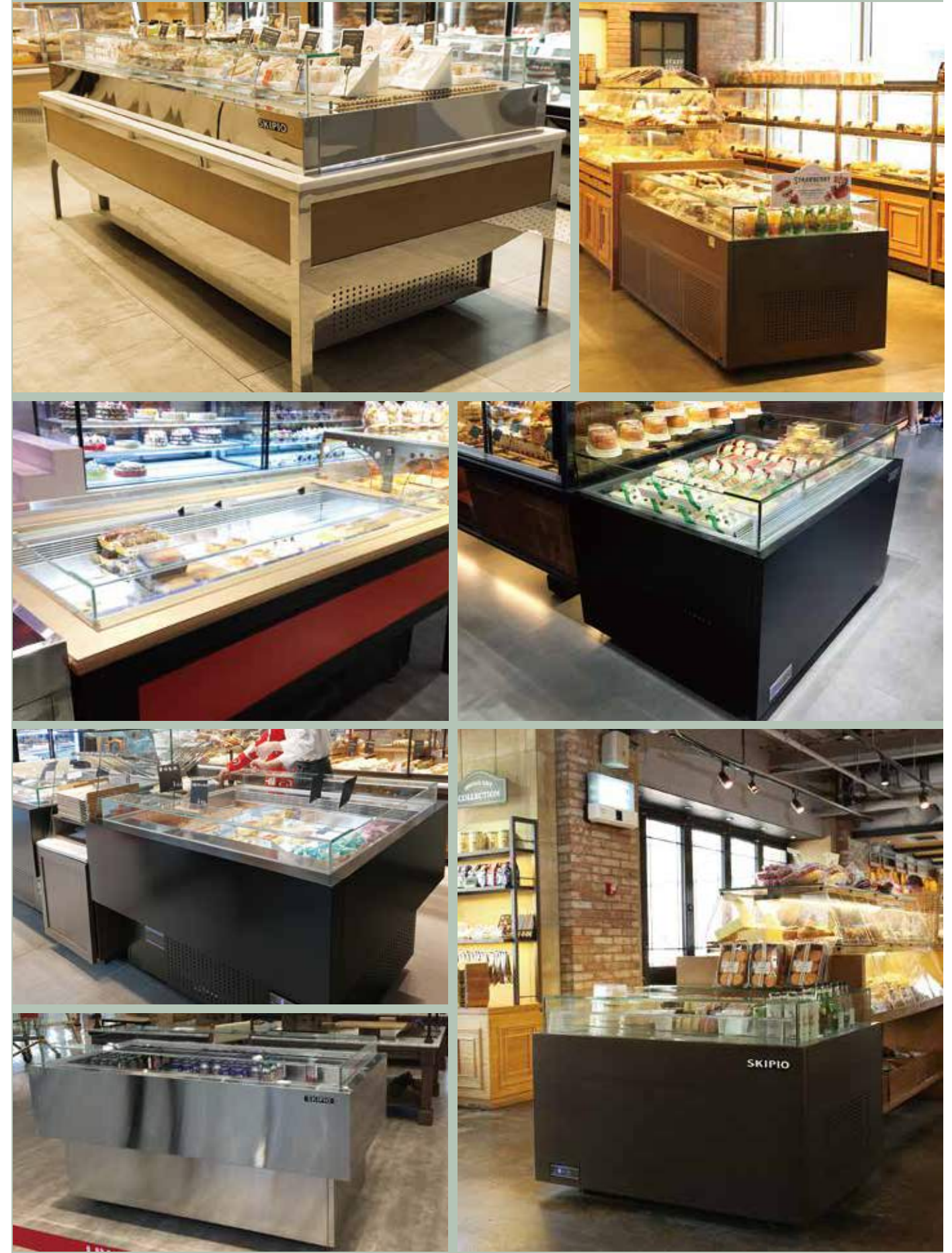

DISPLAY PRODUCT

REACH-IN

UNDER COUNTER

ICE MAKER

SPECIAL MODEL

BAKING LINE

DISH WASHER



CHOCOLATE CASE



BACK VIEW



DRAWER



DIGITAL THERMOMETER



SMALL LED LAMP

SKIPIO

CHOCOLATE CASE

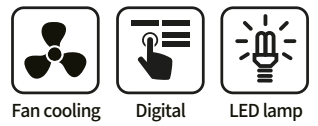

SCD-1200D

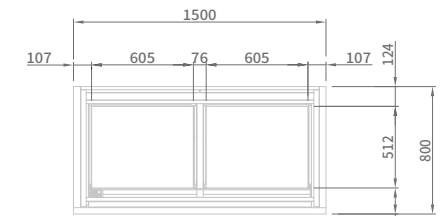

FRONT

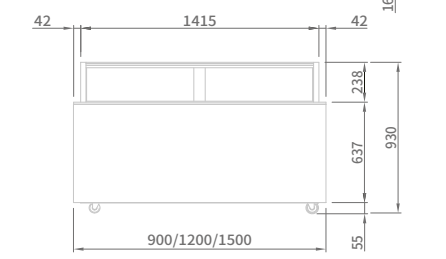

SCD-900D



SCD-1500D

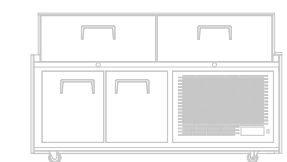

BACK

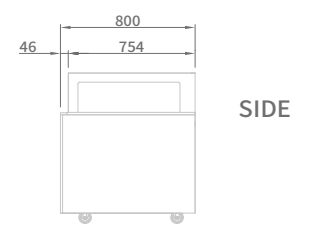

SIDE

MODEL	SCD-900D	SCD-1200D	SCD-1500D
Classification	Refrigerator		
Cabinet dimension (WxDxH mm)	900 / 1200 / 1500 x 800 x 930		
Capacity (ℓ)	85	108	130
Inner Temperature (°C)	10 ~ 14 Humidity 50 ± 5%		
Refrigerant	R-134a		
Insulation Type	Polyurethane / Cyclopentane + CFC Free		
Amps (A)	2.1	2.5	3
Voltage (V/Hz/Ph)	220 / 50 / 1		
Weight (Kg)	160	190	240
Door type	Drawer / Door		
# of Drawer	1	2	2
# of doors	1	3	4
Compressor (HP)	1/3	1/3	1/3

DISPLAY PRODUCT

REACH-IN

UNDER COUNTER

ICE MAKER

SPECIAL MODEL

BAKING LINE

DISH WASHER

GELATO SHOWCASE

GELATO CASE
TABLE GELATO CASE
ICE CREAM DIPPING CABINET



TABLE GELATO CASE

SKIPIO

GELATO SHOWCASE

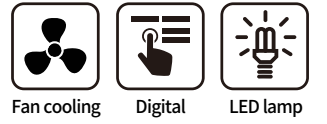

SGC-1200F

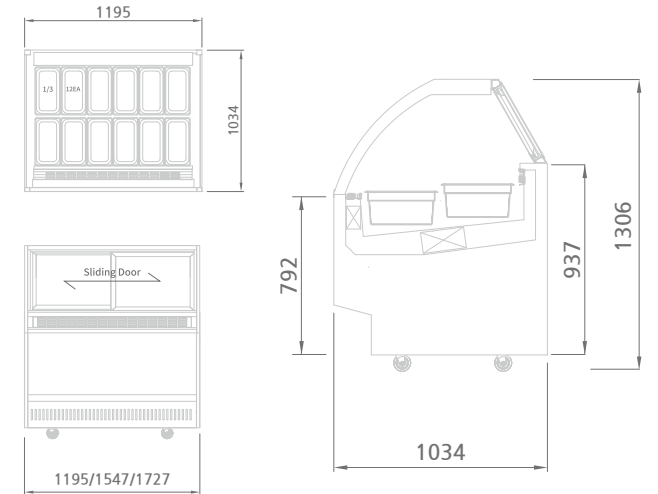

SGC-1200F (White)

SGC-1500F

SGC-1800F



MODEL	SGC-1200F	SGC-1500F	SGC-1800F
Classification		Freezer	
Cabinet dimension (WxDxH mm)		1195 / 1547 / 1727 x 1034 x 1306	
# of 1/3 Pans	12	16	18
# of 1/2 Pans	8	10	12
Inner Temperature (°C)		-25 ~ -15	
Refrigerant		R-404a	
Insulation Type		Polyurethane / Cyclopentane + CFC Free	
Amps (A)	4.7	5.2	5.7
Voltage (V/Hz/Ph)		220 / 50 / 1	220 / 50 / 1
Weight (Kg)	200	260	300
Door Type		Sliding Doors / Curtain	
Compressor (HP)	1+	1+	1+

DISPLAY PRODUCT

REACH-IN

UNDER COUNTER

ICE MAKER

SPECIAL MODEL

BAKING LINE

DISH WASHER

TABLE GELATO CASE

SGT-700

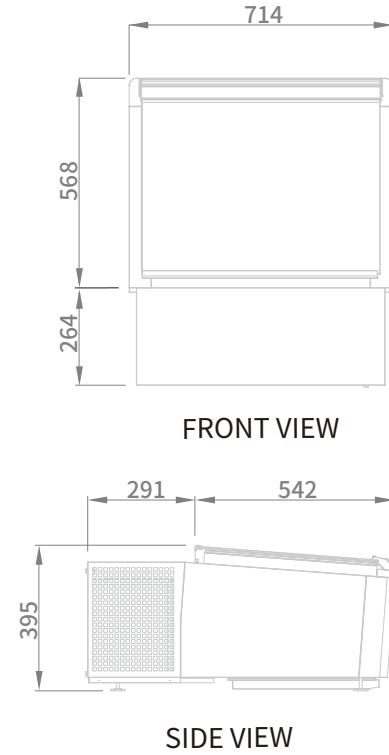
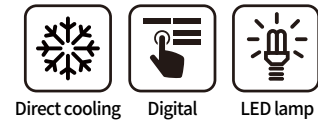

Easy Reversible Door



GN Pan Size

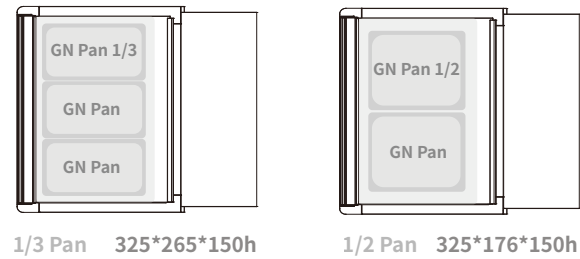

MODEL	SGT-700
Classification	Freezer
Cabinet dimension (WxDxH mm)	714 x 831 x 395
# of 1/3 Pans	3
# of 1/2 Pans	2
Inner Temperature (°C)	-25~-15
Refrigerant	R-404a
Insulation Type	Polyurethane / Cyclopentane + CFC Free
Amps (A)	2
Voltage (V/Hz/Ph)	220 / 50 / 1
Weight (Kg)	45
Door Type	Glass Door
Door Attachment	Front door / Back door

ICE CREAM DIPPING CABINET

SIDC-70W

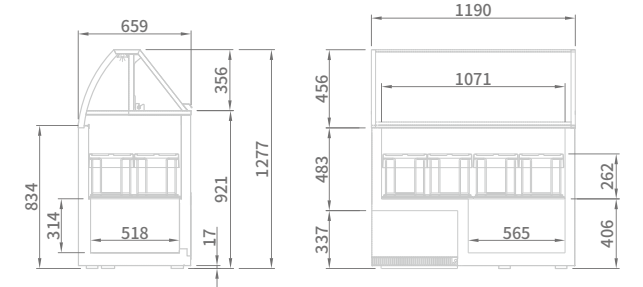
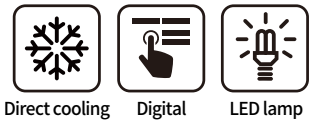

SIDC-47W

SIDC-91W

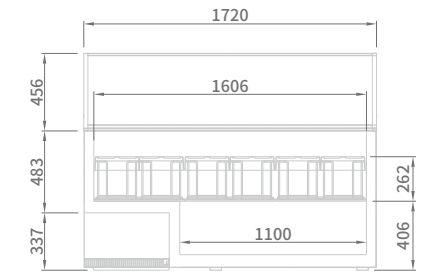

MODEL	SIDC-47W	SIDC-70W	SIDC-91W
Classification		Freezer	
Cabinet dimension (WxDxH mm)		1190 / 1720 / 2250 x 659 x 1277	
Capacity (ℓ)	286	607	834
Inner Temperature (°C)		-25 ~ -15	
Doors	Acryl	1	2
	Cabinet	1	2
# of Racks	8	12	16
Refrigerant		R-404a	
Insulation Type		Polyurethane / Cyclopentane + CFC Free	
Compressor (HP)	1/2	1	1+
Amps (A)	5	6	6.5
Voltage (V/Hz/Ph)		220 / 50 / 1	
Power (W)	500	804	854
Weight (Kg)	140	170	230



BACK BAR



BACK BAR



SB9-2G

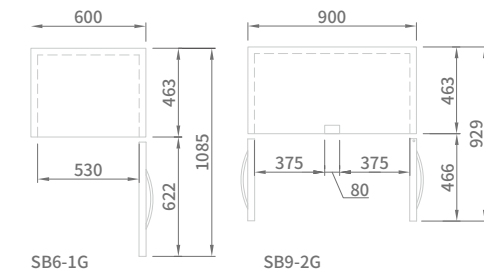

SB6-1G

SB9-2G

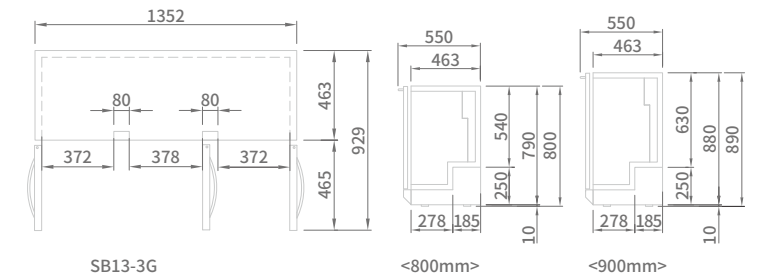

SB13-3G

<800mm>

<900mm>

COLOR :

SB6-1G

SB13-3G

SB9-2GS / SB13-2GS - Sliding door



MODEL	SB6-1G	SB9-2G	SB13-3G	SB9-2GS	SB13-2GS
Classification				Refrigerator	
Cabinet dimension (WxDxH mm)	600 x 550 x 900 / 800	900 x 550 x 900 / 800	1352 x 550 x 900 / 800	900 x 463 x 900 / 800	1352 x 463 x 900 / 800
Capacity (ℓ)	125 / 110	190 / 165	300 / 261	190 / 165	300 / 261
Inner Temperature (°C)			1~ 8		
Refrigerant			R-134a		
Insulation Type			Polyurethane / Cyclopentane + CFC Free		
Amps (A)	2.5	2.5	3.5	2.5	3.5
Voltage (V/Hz/Ph)			220 / 50 / 1		
Weight (Kg)	60	75	100	75	100
Door type	Swing door	Swing door	Swing door	Sliding door	Sliding door
# of doors	1	2	3	2	2
Compressor (HP)	1/4	1/4	1/3	1/4	1/3
Power (W)	190	190	330	190	330
# of Shelves	1	2	3	2	2

DISPLAY PRODUCT

REACH-IN

UNDER COUNTER

ICE MAKER

SPECIAL MODEL

BAKING LINE

DISH WASHER

GLASS DOOR MERCHANDISER

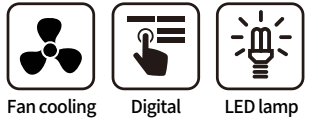

GLASS DOOR MERCHANDISER

GLASSDOOR MERCHANDISER
[SWING DOOR]

GLASSDOOR MERCHANDISER
[SLIDING DOOR]

SKIPIO

SGM-5 SGF-5



SGM-14



SGF-14



SGM-18



SGF-18

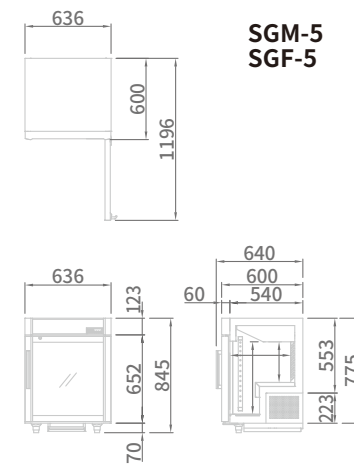

SGM-5
SGF-5

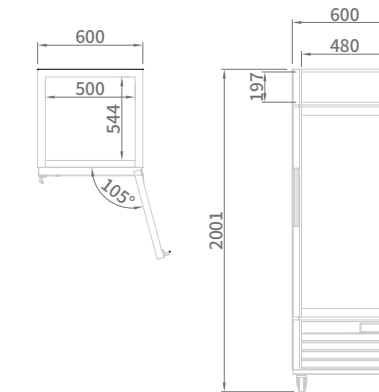

SGM-14
SGF-14

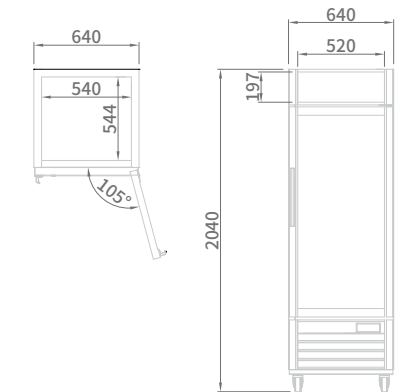

SGM-18
SGF-18

MODEL	SGM-5/SGF-5	SGM-14/SGF-14	SGM-18/SGF-18
Classification		Refrigerator / Freezer	
Cabinet dimension (WxDxH mm)	636 x 600 x 845	600 x 700 x 2001	640 x 700 x 2040
Capacity (ℓ)	100	375	420
Inner Temperature (°C)	1~8 / -25 ~ -15	1~8 / -25 ~ -15	1~8 / -25 ~ -15
Refrigerant		R-134a / R-404a	
Insulation Type		Polyurethane / Cyclopentane + CFC Free	
Amps (A)	1.3 / 1.7	1.7 / 3	1.7 / 3
Voltage (V/Hz/Ph)		220 / 50 / 1	
Weight (Kg)	60	70	80
Door type		Swing door	
# of doors	1	1	1
Power (W)	200 / 300	380 / 642	380 / 642
# of Shelves	3	3	3

DISPLAY PRODUCT

REACH-IN

UNDER COUNTER

ICE MAKER

SPECIAL MODEL

BAKING LINE

DISH WASHER

GLASS DOOR MERCHANDISER



GLASS DOOR MERCHANDISER

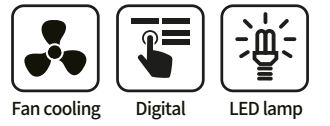

SGM-20

SGF-20

SGM-25

SGF-25



SGM-35

SGM-49

SGM-72

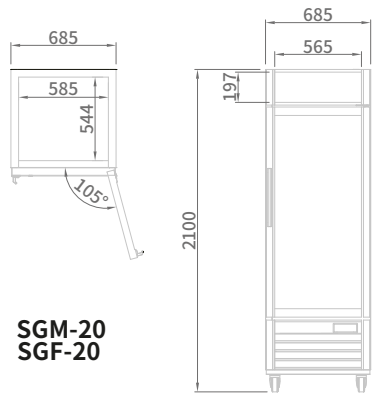

SGM-20
SGF-20

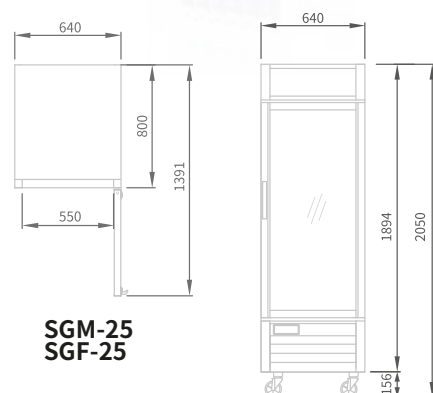

SGM-25
SGF-25

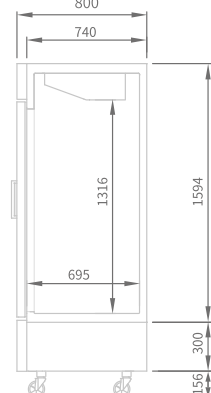

Size Optional

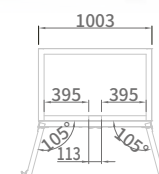

SGM-35



SGM-49

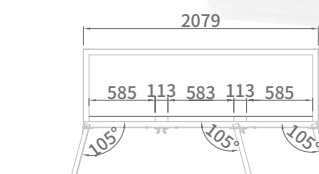

SGM-72

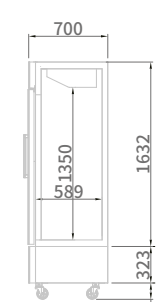
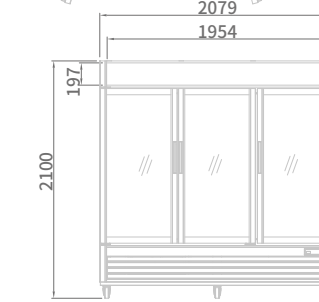
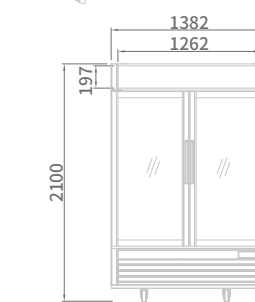
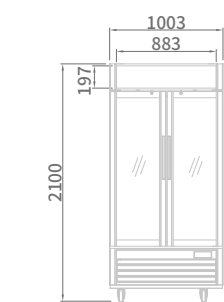

MODEL	SGM-20/SGF-20	SGM-25/SGF-25
Classification	Refrigerator / Freezer	
Cabinet dimension (WxDxH mm)	685 x 700 x 2100	640 x 800 x 2050
Capacity (ℓ)	470	510
Inner Temperature (°C)	1 ~ 8 / -25 ~ -15	
Refrigerant	R-134a / R-404a	
Insulation Type	Polyurethane / Cyclopentane + CFC Free	
Amps (A)	1.7 / 3.5	2.2 / 2.8
Voltage (V/Hz/Ph)	220 / 50 / 1	
Weight (Kg)	85	90
Door type	Swing door	
# of doors	1	1
Power (W)	380 / 680	412 / 878
# of Shelves	3	3

MODEL	SGM-35	SGM-49	SGM-72
Classification	Refrigerator		
Cabinet dimension (WxDxH mm)	1003 x 700 x 2100	1382 x 700 x 2001	2079 x 700 x 2040
Capacity (ℓ)	752	1039	1604
Inner Temperature (°C)	1 ~ 8		
Refrigerant	R-134a		
Insulation Type	Polyurethane/ Cyclopentane + CFC Free		
Amps (A)	2	2	5.5
Voltage (V/Hz/Ph)	220 / 50 / 1		
Weight (Kg)	140	160	220
Door type	Swing door		
# of doors	2	2	3
Power (W)	435	435	550
# of Shelves	6	6	9

DISPLAY PRODUCT REACH-IN UNDER COUNTER ICE MAKER SPECIAL MODEL BAKING LINE DISH WASHER

GLASS DOOR MERCHANDISER

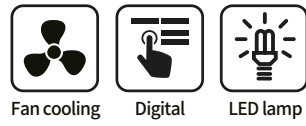

GLASS DOOR MERCHANDISER

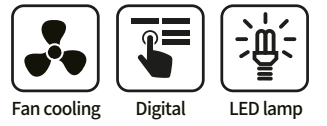

SGF-35

SGF-49

SGF-72

SGM-35S

SGM-49S

SGM-72S

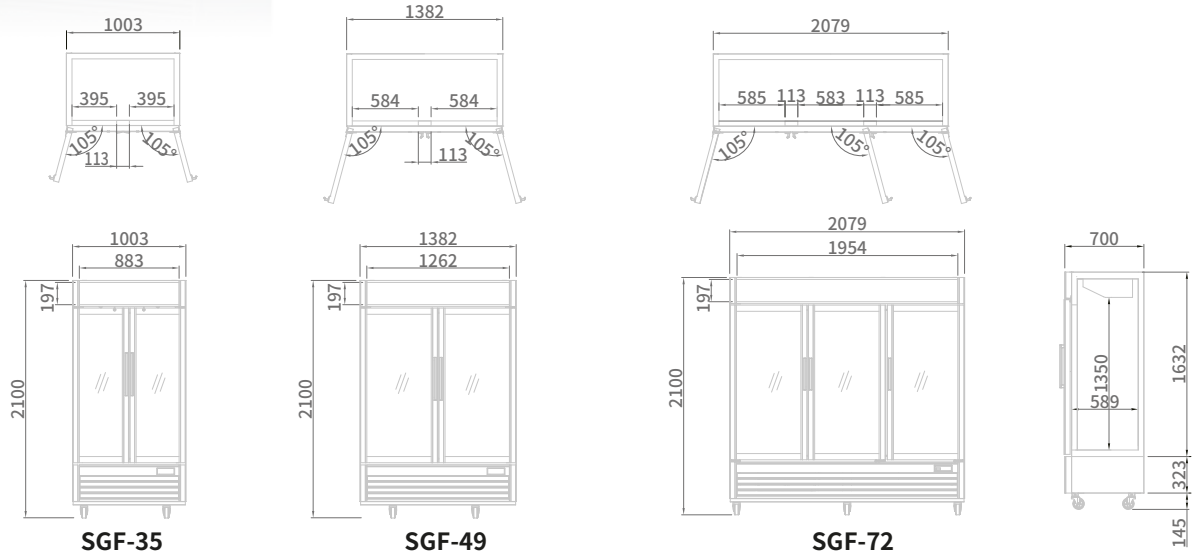

型号 / MODEL	SGF-35	SGF-49	SGF-72
Classification		Freezer	
Cabinet dimension (WxDxH mm)	1003 x 700 x 2100	1382 x 700 x 2001	2079 x 700 x 2040
Capacity (ℓ)	752	1039	1604
Inner Temperature (°C)		-25 ~ -15	
Refrigerant		R-404a	
Insulation Type		Polyurethane / Cyclopentane + CFC Free	
Amps (A)	4.5	5.2	8.6
Voltage (V/Hz/Ph)		220 / 50 / 1	
Weight (Kg)	140	160	220
Door type		Swing door	
# of doors	2	2	3
Power (W)	982	1025	1125
# of Shelves	6	6	9

MODEL	SGM-35S	SGM-49S	SGM-72S
Classification		Refrigerator	
Cabinet dimension (WxDxH mm)	1003 x 700 x 2100	1382 x 700 x 2001	2079 x 700 x 2040
Capacity (ℓ)	752	1039	1604
Inner Temperature (°C)		1 ~ 8	
Refrigerant		R-134a	
Insulation Type		Polyurethane / Cyclopentane + CFC Free	
Amps (A)	2	2	5.5
Voltage (V/Hz/Ph)		220 / 50 / 1	
Weight (Kg)	140	160	220
Door type		Sliding door	
# of doors	2	2	3
Power (W)	435	435	550
# of Shelves	6	6	9

DISPLAY PRODUCT
REACH-IN
UNDER COUNTER
ICE MAKER
SPECIAL MODEL
BAKING LINE
DISH WASHER



REACH-IN Dual temp

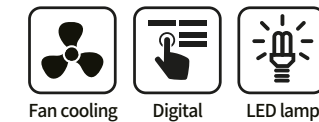

SRFT25-2
SRFT25-2P



SRFT45-2/SRFT45-4
SRFT45-2P / SRFT45-4P



SRFT65-3 / SRFT65-6
SRFT65-3P / SRFT65-6P



REACH-IN

REFRIGERATOR / FREEZER



- BUN PAN TYPE



SKIPIO

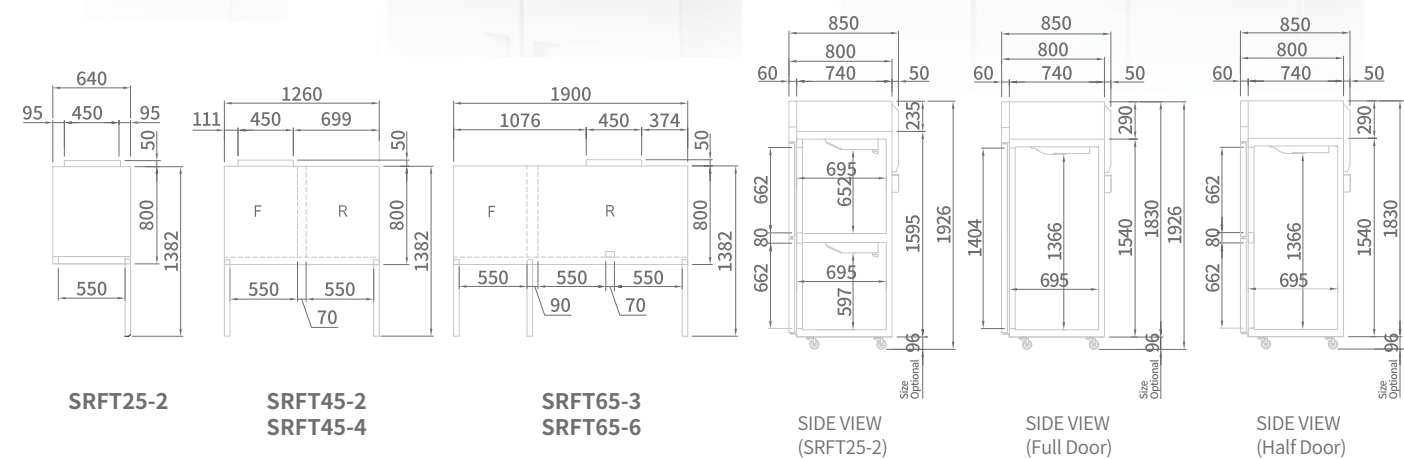

SRFT25-2 SRFT45-2 / SRFT45-4 SRFT65-3 / SRFT65-6 SIDE VIEW (SRFT25-2) SIDE VIEW (Full Door) SIDE VIEW (Half Door)

MODEL	SRFT25-2 SRFT25-2P	SRFT45-2 / SRFT45-4 SRFT45-2P / SRFT45-4P	SRFT65-3 / SRFT65-6 SRFT65-3P / SRFT 65-6P
Classification		Refrigerator + Freezer	
Cabinet dimension (WxDxH mm)	640 x 850 x 1926	1260 x 850 x 1926	1900 x 850 x 1926
Capacity (ℓ)	242 / 222	576 / 576	1235 / 575
Inner Temperature (°C)		1~ 8 / -21 ~ -12	
Refrigerant	R-404a	R-134a / R-404a	R-134a / R-404a
Insulation Type		Polyurethane / Cyclopentane + CFC Free	
Amps (A)	3.5	4.5	5.5
Voltage (V/Hz/Ph)		220 / 50 / 1	
Weight (Kg)	85	152	177
Power (W)	366	732	1098
# of doors	2	2 / 4	3 / 6
Compressor (HP)	1/2	1/3 1/2	1/3 3/4
# of Shelves	1/1	3/3	6/6

DISPLAY PRODUCT REACH-IN UNDER COUNTER ICE MAKER SPECIAL MODEL BAKING LINE DISH WASHER

REACH-IN REFRIGERATOR / FREEZER

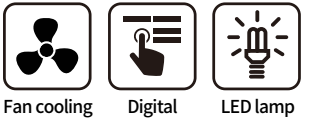

SRT25-2 / SRT25-2P
SFT25-2 / SFT25-2P

SRT45-4 / SRT45-4P
SFT45-4 / SFT45-4P

SRT65-6 / SRT65-6P
SFT65-6 / SFT65-6P

SRT25-1 / SRT25-1P
SFT25-1 / SFT25-1P

SRT45-2 / SRT45-2P
SFT45-2 / SFT45-2P

SRT65-3 / SRT65-3P
SFT65-3 / SFT65-3P



of BUN PAN
25 model : 13ea
45 model : 26ea
65 model : 39ea

MODEL	SRT25-1 SFT25-1	SRT25-2 SFT25-2	SRT45-2 SFT45-2	SRT45-4 SFT45-4	SRT65-3 SFT65-3	SRT65-6 SFT65-6
Classification	Refrigerator / Freezer					
Inner Temperature (°C)	1~8 / -21~-12					
Refrigerant	R-134a / R-404a					
Cabinet dimension (WxDxH mm)	640 x 850 x 1926		1260 x 850 x 1926		1900 x 850 x 1926	
Capacity (ℓ)	574	572	1215	1210	1876	1868
Insulation Type	Polyurethane / Cyclopentane + CFC Free					
Amps (A)	2.8 / 3.5	2.8 / 3.5	3.5 / 3.5	3.5 / 5.3	6 / 8.5	6 / 8.5
Voltage (V/Hz/Ph)	220 / 50 / 1					
Weight (Kg)	77 / 80	77 / 80	142 / 142	142 / 142	167 / 167	167 / 167
Power (W)	314 / 496	314 / 496	366 / 774	366 / 774	732 / 1346	732 / 1346
# of doors	1	2	2	4	3	6
Compressor (HP)	1/4 2/3	1/4 2/3	1/3 1	1/3 1	3/4 3/4 x 2	3/4 3/4 x 2
# of Shelves	3	3	6	6	9	9

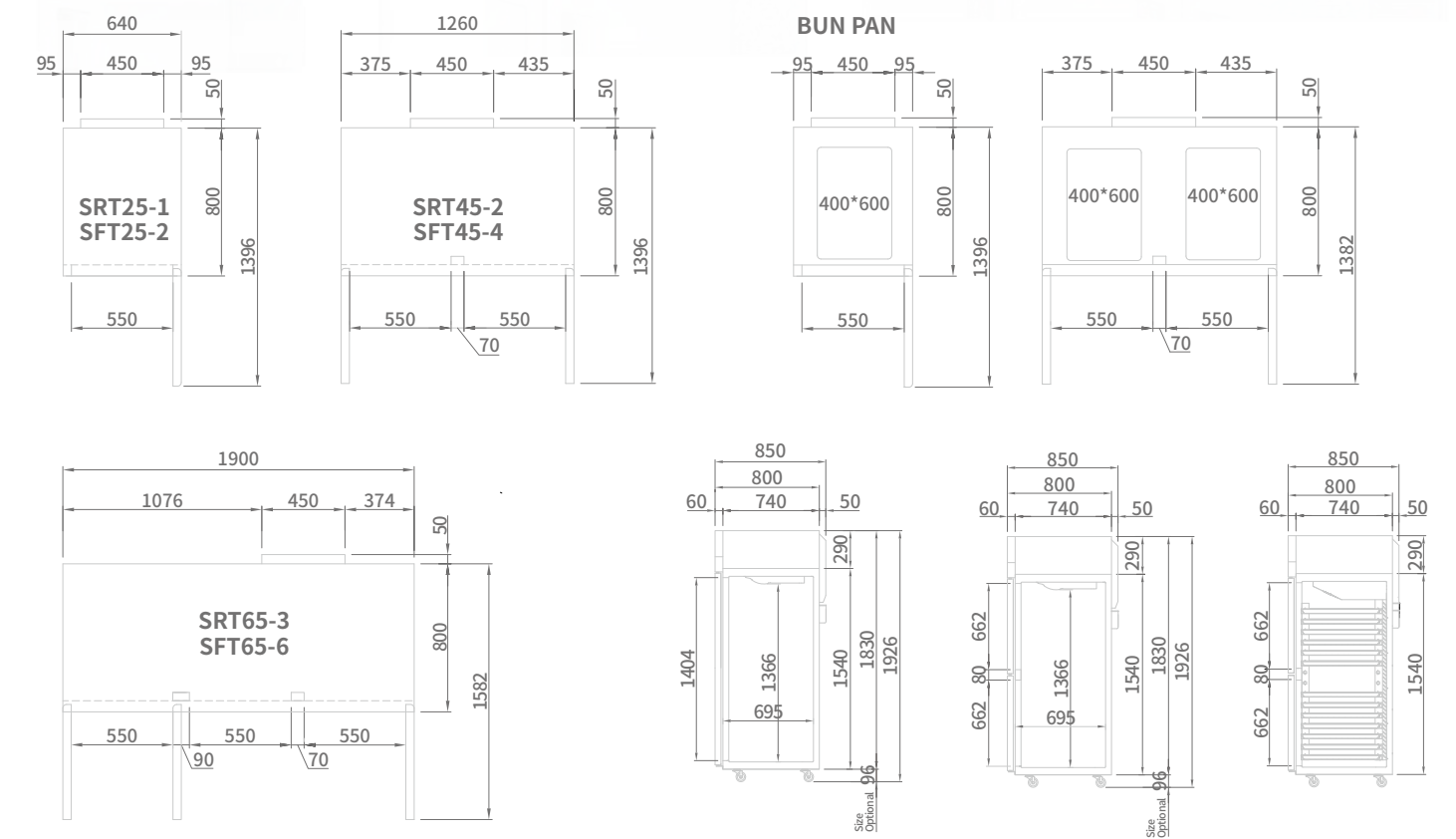

DISPLAY PRODUCT
REACH-IN
UNDER COUNTER
ICE MAKER
SPECIAL MODEL
BAKING LINE
DISH WASHER



REACH-IN [GLASS DOOR]

REFRIGERATOR / FREEZER

SKIPIO

REACH-IN [GLASS DOOR] FREEZER

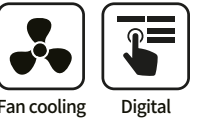

SFT25-1G

SFT25-2G

SFT45-2G

SFT45-4G

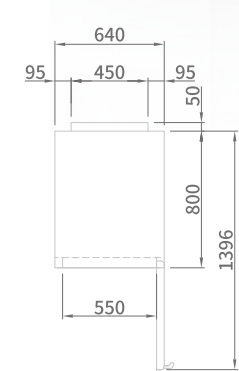

SFT25-1G
SFT25-2G

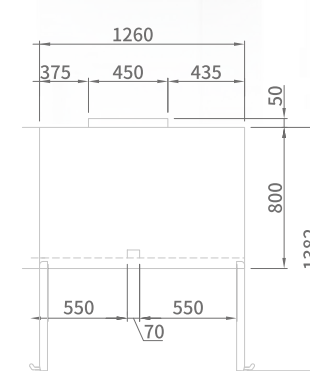

SFT45-2G
SFT45-4G

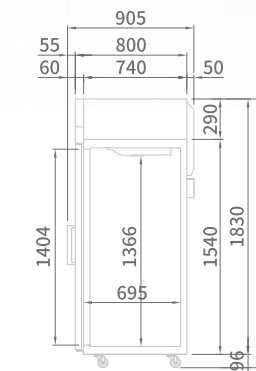

SIDE VIEW
(Glass Door)

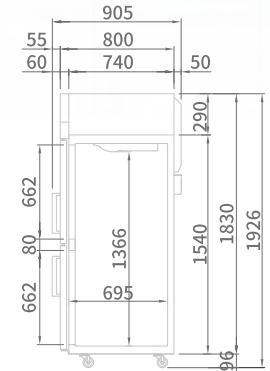

SIDE VIEW
(Half Glass Door)

MODEL	SFT25-1G	SFT25-2G	SFT45-2G	SFT45-4G
Classification			Freezer	
Cabinet dimension (WxDxH mm)	640 x 850 x 1926	640 x 850 x 1926	1260 x 850 x 1926	1260 x 850 x 1926
Capacity (ℓ)	574	572	1215	1210
Inner Temperature (°C)			-21 ~ -12	
Refrigerant			R-404a	
Insulation Type			Polyurethane / Cyclopentane + CFC Free	
Amps (A)	4.5	4.5	8	8
Voltage (V/Hz/Ph)			220 / 50 / 1	
Weight (Kg)	95	95	170	170
Power (W)	660	660	976	976
# of doors	1	2	2	4
Compressor (HP)	6/7	6/7	2/3x2	2/3x2
# of Shelves	3	3	6	6

DISPLAY PRODUCT

REACH-IN

UNDER COUNTER

ICE MAKER

SPECIAL MODEL

BAKING LINE

DISH WASHER

REACH-IN [GLASS DOOR] REFRIGERATOR

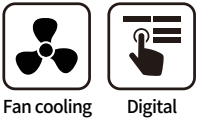

SRT25-1G

SRT45-2G

SRT65-3G

SRT25-2G

SRT45-4G

SRT65-6G



MODEL	SRT25-1G	SRT25-2G	SRT45-2G	SRT45-4G	SRT65-3G	SRT65-6G
Classification	Refrigerator					
Cabinet dimension (WxDxH mm)	640 x 850 x 1926		1260 x 850 x 1926		1900 x 850 x 1926	
Capacity (ℓ)	574	572	1215	1210	1876	1868
Inner Temperature (°C)	1 ~ 8					
Refrigerant	R-134a					
Insulation Type	Polyurethane / Cyclopentane + CFC Free					
Amps (A)	2.8	2.8	2.9	3.5	6	6
Voltage (V/Hz/Ph)	220 / 50 / 1					
Weight (Kg)	87	87	152	152	177	177
Power (W)	314	314	366	366	732	732
# of doors	1	2	2	4	3	6
Compressor (HP)	1/4	1/4	1/3	1/3	1/3x2	1/3x2
# of Shelves	3	3	6	6	9	9

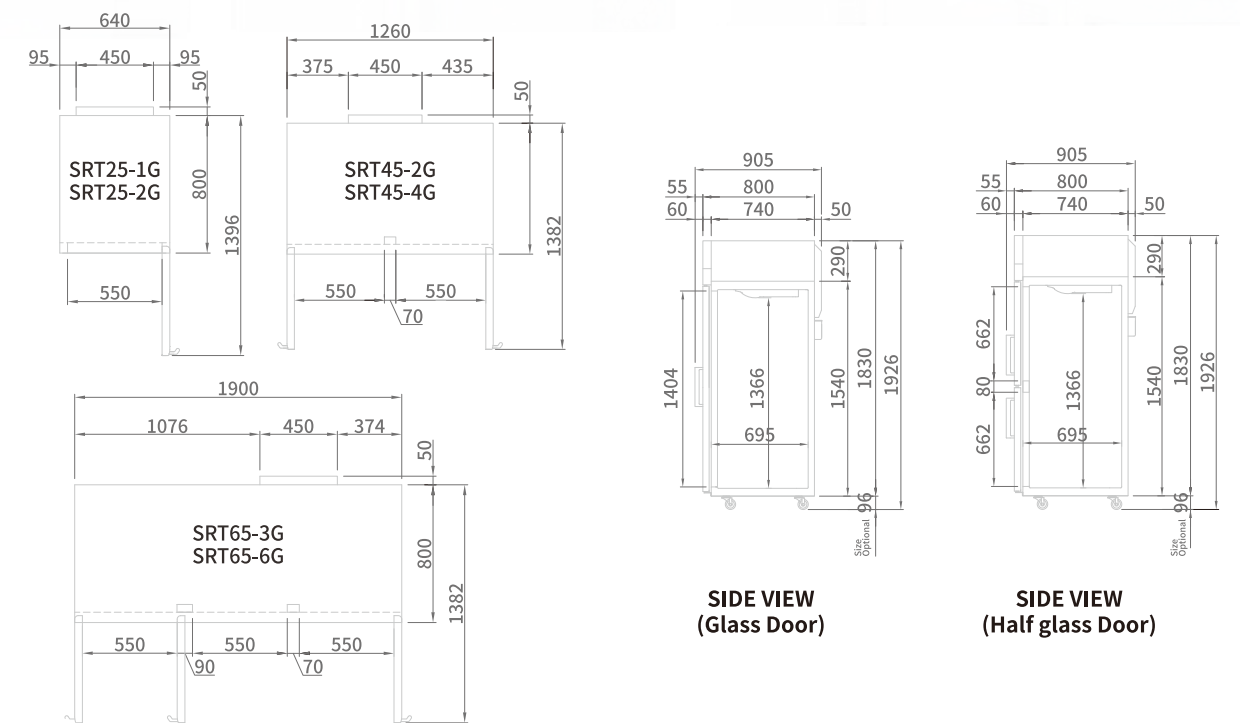

DISPLAY PRODUCT
REACH-IN
UNDER COUNTER
ICE MAKER
SPECIAL MODEL
BAKING LINE
DISH WASHER



UNDER COUNTER

- UNDER COUNTER
- UNDER COUNTER [BUN PAN]
- UNDER COUNTER [GLASS DOOR]
- UNDER COUNTER [DRAWER]



SKIPIO

UNDER COUNTER

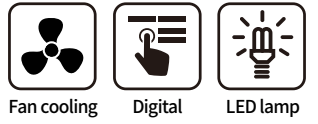

SUR9-1
SUF9-1

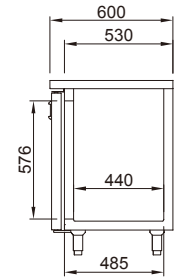
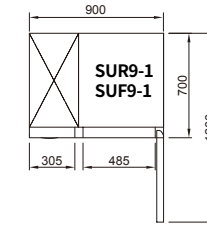

SUR12-2
SUF12-2

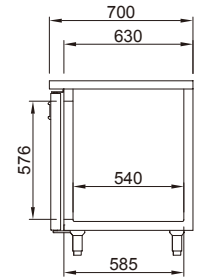
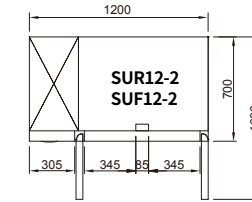

SUR15-2
SUF15-2

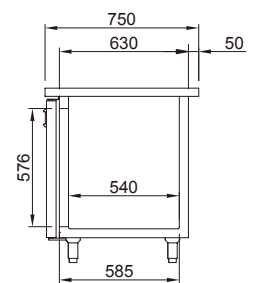
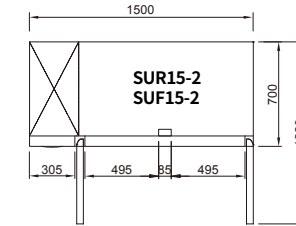

SUR18-3
SUF18-3

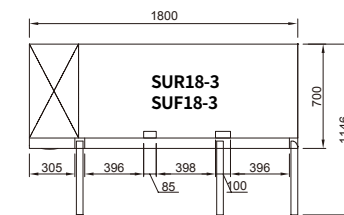

DISPLAY PRODUCT

REACH-IN

UNDER COUNTER

ICE MAKER

SPECIAL MODEL

BAKING LINE

DISH WASHER

MODEL	SUR9-1 SUF9-1	SUR12-2 SUF12-2	SUR15-2 SUF15-2	SUR18-3 SUF18-3
Classification	Refrigerator / Freezer			
Cabinet dimension (WxDxH mm)	900x 700(600) x 850	1200 x 700(600) x 850	1500 x 700(600) x 850	1800 x 700(600) x 850
Capacity (ℓ)	179	280	395	505
Inner Temperature (°C)	-2~ 8 / -21 ~ -12			
Refrigerant	R-134a/R-134a	R-134a/R-404a	R-134a/R-404a	R-134a/R-404a
Insulation Type	Polyurethane / Cyclopentane + CFC Free			
Amps (A)	2.3/2.3	2.5/2.5	2.5/3	3/4.4
Voltage (V/Hz/Ph)	220 / 50 / 1			
Weight (Kg)	72	84	93	109
Power (W)	314/366	314/613	314/613	366/613
# of doors	1	2	2	3
Compressor (HP)	1/4 1/3	1/4 1/3	1/4 3/4	1/3 3/4
# of Shelves	1	2	2	3



UNDER COUNTER [BUN PAN]

CONDENSER EASY CLEANING



SKIPIO

UNDER COUNTER [BUN PAN]

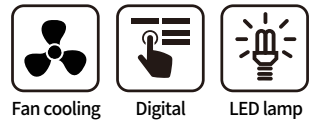

SUR15-2P
SUF15-2P



SUR18-3P
SUF18-3P

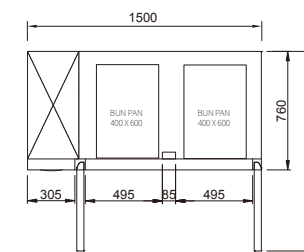

SUR15-2P
SUF15-2P

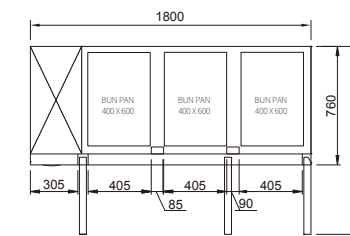

SUR18-3P
SUF18-3P

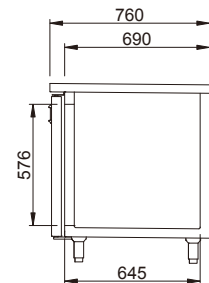

MODEL	SUR15-2P SUF15-2P	SUR18-3P SUF18-3P
Classification	Refrigerator / Freezer	
Cabinet dimension (WxDxH mm)	1500 x 760 x 850	1800 x 760 x 850
Capacity (ℓ)	425	538
Inner Temperature (°C)	-2~ 8 / -21 ~ -12	-2~ 8 / -21 ~ -12
Refrigerant	R-134a/R-404a	R-134a/R-404a
Insulation Type	Polyurethane / Cyclopentane + CFC Free	
Amps (A)	2.5/3	3/4.4
Voltage (V/Hz/Ph)	220 / 50 / 1	
Weight (Kg)	93	109
Power (W)	314/613	366/613
# of doors	2	3
Compressor (HP)	1/4 3/4	1/3 3/4
# of Shelves	2	3

DISPLAY PRODUCT

REACH-IN

UNDER COUNTER

ICE MAKER

SPECIAL MODEL

BAKING LINE

DISH WASHER

UNDER COUNTER Dual temp



SURF12-2

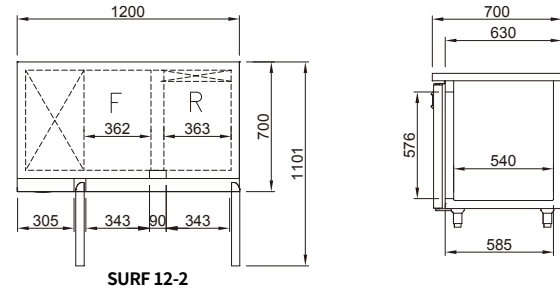

SURF15-2

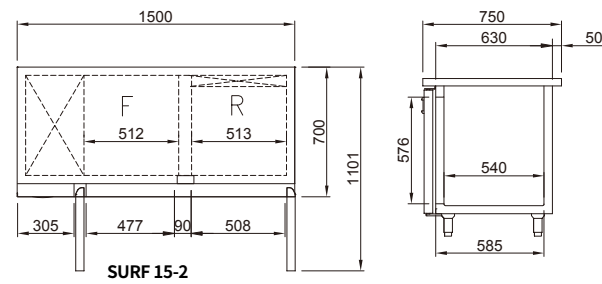
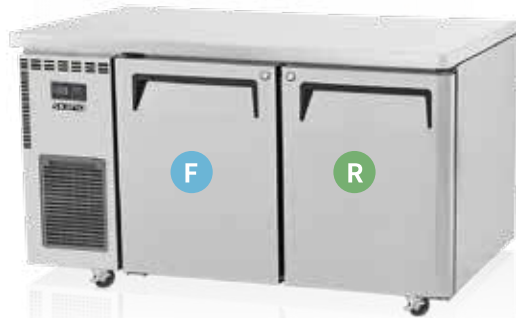

SURF18-3

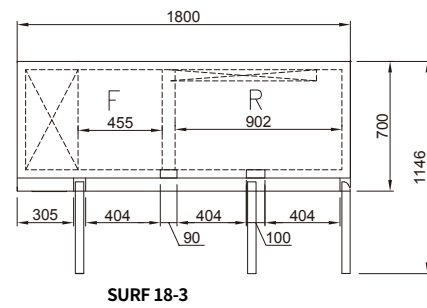

MODEL	SURF12-2	SURF15-2	SURF18-3
Classification	Refrigerator / Freezer	Refrigerator / Freezer	Refrigerator / Freezer
Cabinet dimension (WxDxH mm)	1200x 700 x 850	1500x 700 x 850	1800x 700 x 850
Capacity (ℓ)	127/135	178/190	333/154
Inner Temperature (°C)		-2~ 8 / -21 ~ -12	
Refrigerant	R-134a	R-404a	R-404a
Insulation Type	Polyurethane / Cyclopentane + CFC Free		
Amps (A)	3	4.35	4.4
Voltage (V/Hz/Ph)	220 / 50 / 1		
Weight (Kg)	92	101	120
Power (W)	316	316	366
# of doors	2	2	3
Compressor (HP)	1/3	3/4	3/4
# of Shelves	1	1	2

UNDER COUNTER Glass door

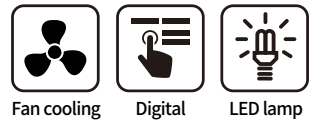

SGR9-1

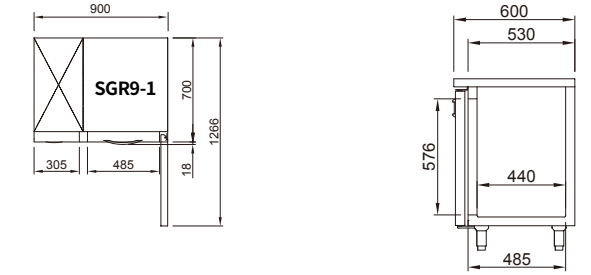

SGR12-2

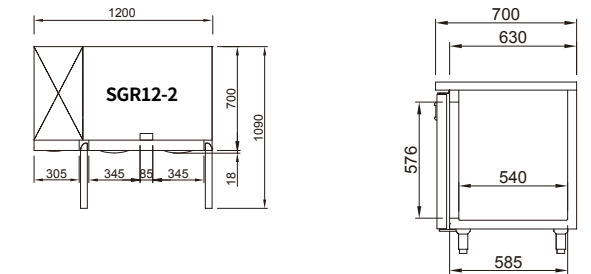

SGR15-2

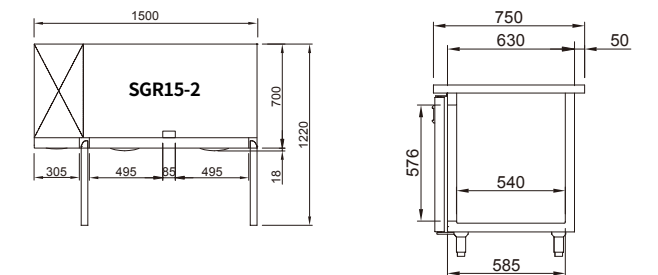

SGR18-3

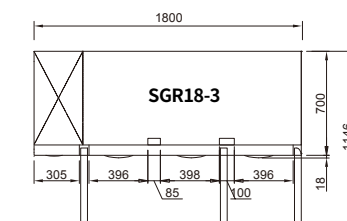

MODEL	SGR9-1	SGR12-2	SGR15-2	SGR18-3
Classification	Refrigerator			
Cabinet dimension (WxDxH mm)	900x 700(600) x 850	1200x 700(600)x 850	1500x 700(600) x 850	1800x 700(600) x 850
Capacity (ℓ)	179	280	395	505
Inner Temperature (°C)	-2~ 8			
Refrigerant	R-134a	R-134a	R-134a	R-134a
Insulation Type	Polyurethane / Cyclopentane + CFC Free			
Amps (A)	2.3	2.5	2.5	3
Voltage (V/Hz/Ph)	220 / 50 / 1			
Weight (Kg)	80	96	110	127
Power (W)	314	314	314	366
# of doors	1	2	2	3
Compressor (HP)	1/4	1/4	1/4	1/3
# of Shelves	1	2	2	3

UNDER COUNTER Drawer

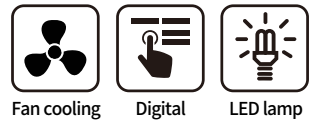

SUR9-3D-3
SUF9-3D-3

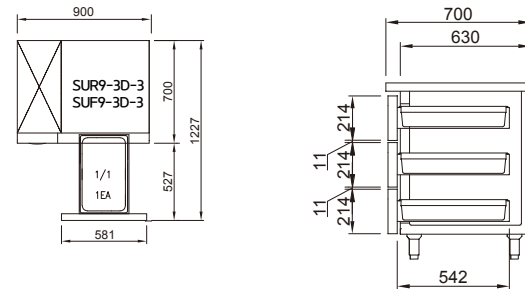

SUR12-3D-3
SUF12-3D-3

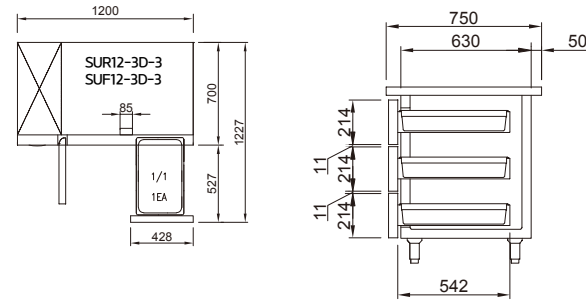

SUR12-3D-6
SUF12-3D-6

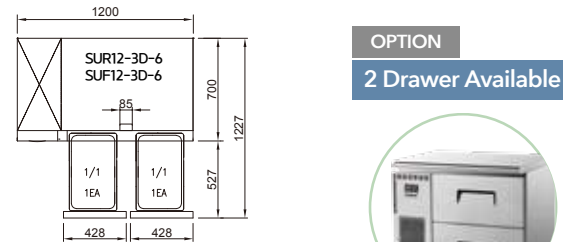

SUR15-3D-3
SUF15-3D-3

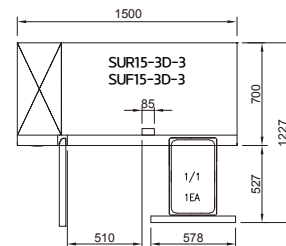

SUR15-3D-6
SUF15-3D-6

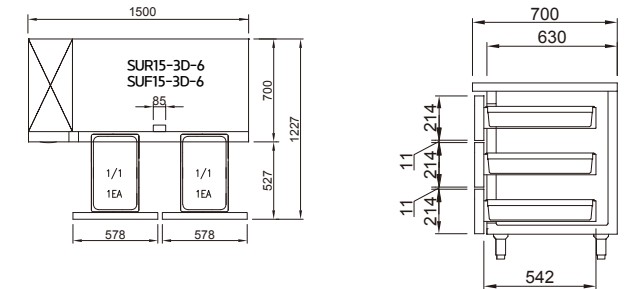

SUR18-3D-3

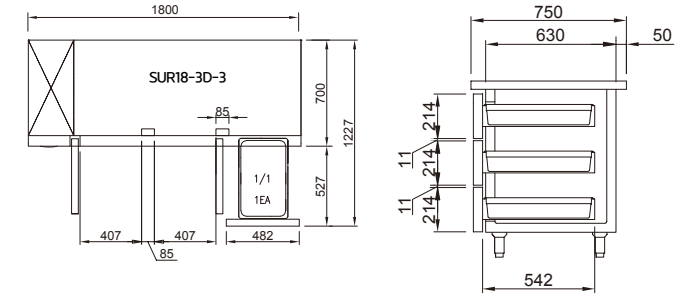

SUR18-3D-6

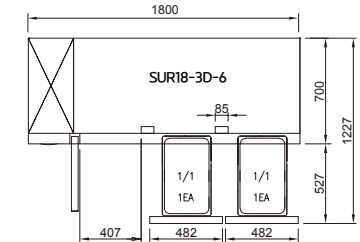

SUR18-3D-9

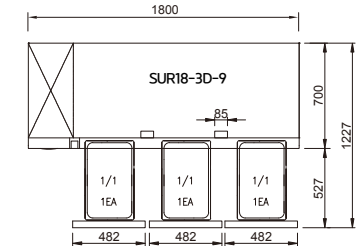

MODEL	SUR9-3D-3 SUF9-3D-3	SUR12-3D-3 SUF12-3D-3	SUR12-3D-6 SUF12-3D-6	SUR15-3D-3 SUF15-3D-3
Classification	Refrigerator / Freezer			
Cabinet dimension (WxDxH mm)	900x 700 x 850	1200x 700 x 850	1200x 700 x 850	1500x 700 x 850
Capacity (ℓ)	179	280	280	395
Inner Temperature (°C)	-2~ 8 / -21 ~ -12			
Refrigerant	R-134a / R-134a	R-134a / R-134a	R-134a / R-134a	R-134a / R-404a
Insulation Type	Polyurethane / Cyclopentane + CFC Free			
Amps (A)	2.3/3	2.5/3.3	2.5/3.3	2.5 / 4.4
Voltage (V/Hz/Ph)	220 / 50 / 1			
Weight (Kg)	84	97	106	107
Power (W)	314/366	314/366	314/366	314/366
# of doors	0	1	0	1
Compressor (HP)	1/4 1/3	1/4 1/3	1/4 1/3	1/4 3/4
# of Shelves	0	1	0	1

MODEL	SUR15-3D-6 SUF15-3D-6	SUR18-3D-3	SUR18-3D-6	SUR18-3D-9
Classification	Refrigerator / Freezer			
Cabinet dimension (WxDxH mm)	1500x 700 x 850	1800x 700 x 850	1800x 700 x 850	1800x 700 x 850
Capacity (ℓ)	395	505	505	505
Inner Temperature (°C)	-2~ 8 / -21 ~ -12	-2~ 8	-2~ 8	-2~ 8
Refrigerant	R-134a / R-404a	R-134a	R-134a	R-134a
Insulation Type	Polyurethane / Cyclopentane + CFC Free			
Amps (A)	2.5/4.4	3	3	3
Voltage (V/Hz/Ph)	220 / 50 / 1			
Weight (Kg)	116	126	135	144
Power (W)	314/366	366	366	366
# of doors	0	2	1	0
Compressor (HP)	1/4 3/4	1/3	1/3	1/3
# of Shelves	0	2	1	0



SALAD & PIZZA TABLE

SALAD SIDE PREP TABLE[BUFFET]
SALAD SIDE PREP TABLE[HOOD]

SKIPIO

SALAD SIDE PREP TABLE BUFFET

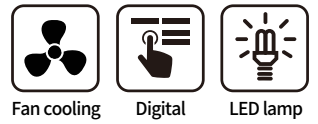

SSR9-1

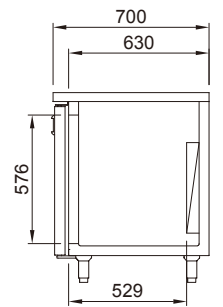
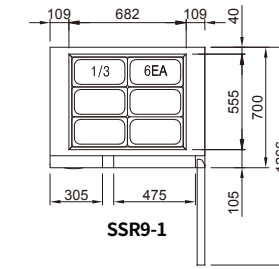

SSR12-2

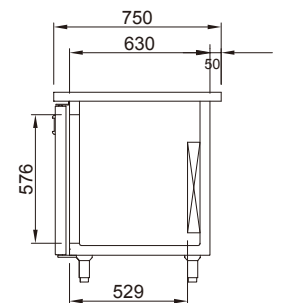
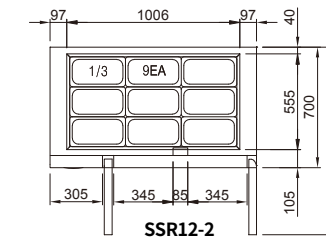

SSR15-2

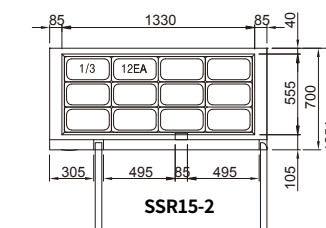

Pans Not Included

SSR18-3

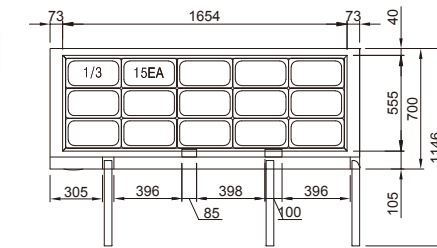

MODEL	SSR9-1	SSR12-2	SSR15-2	SSR18-3
Classification	Refrigerator			
Cabinet dimension (WxDxH mm)	900x 700 x 850	1200x 700 x 850	1500x 700 x 850	1800x 700 x 850
Capacity (ℓ)	233	343	458	568
Inner Temperature (°C)	-2~ 8			
Refrigerant	R-134a	R-134a	R-134a	R-134a
Insulation Type	Polyurethane / Cyclopentane + CFC Free			
Amps (A)	2.3		2.5	3
Voltage (V/Hz/Ph)	220 / 50 / 1			
Weight (Kg)	70	82	91	107
Power (W)	314	314	314	366
# of doors	1	2	2	3
Compressor (HP)	1/4	1/4	1/4	1/3
# of Shelves	1	2	2	3

DISPLAY PRODUCT REACH-IN UNDER COUNTER ICE MAKER SPECIAL MODEL BAKING LINE DISH WASHER

SALAD SIDE PREP TABLE HOOD LID



SHR9-1

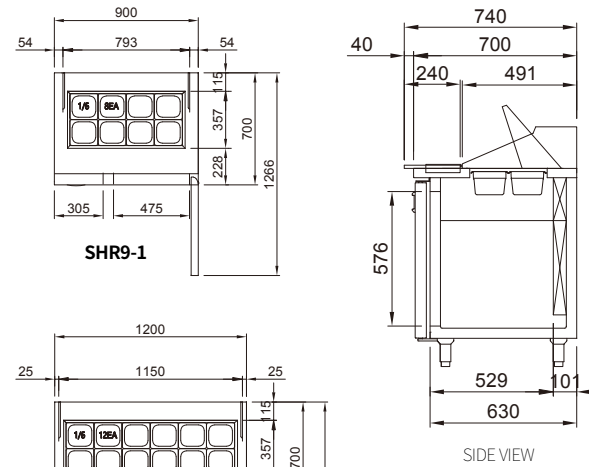

SHR12-2

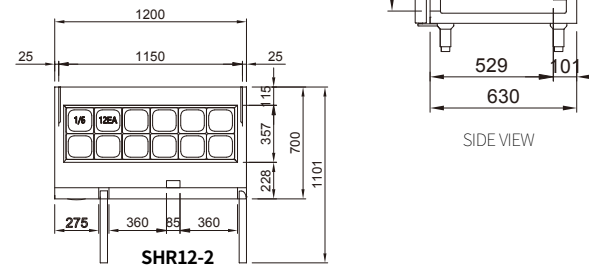

SHR15-2

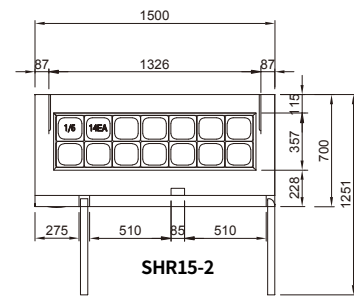

SHR18-3

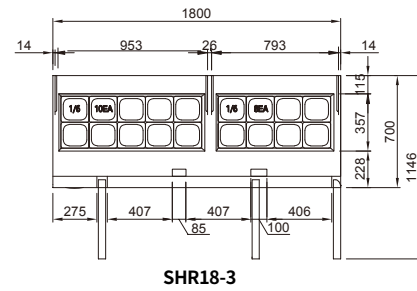

MODEL	SHR9-1	SHR12-2	SHR15-2	SHR18-3
Classification	Refrigerator			
Cabinet dimension (WxDxH mm)	900x 700 x 1028	1200x 700 x 1028	1500x 700 x 1028	1800x 700 x 1028
Capacity (ℓ)	293	432	556	702
Inner Temperature (°C)	-2~ 8			
Refrigerant	R-134a	R-134a	R-134a	R-134a
Insulation Type	Polyurethane / Cyclopentane + CFC Free			
Amps (A)	2.3	2.5	2.5	3
Voltage (V/Hz/Ph)	220 / 50 / 1			
Weight (Kg)	75	89	100	120
Power (W)	314	314	314	366
# of doors	1	2	2	3
Compressor (HP)	1/4	1/4	1/4	1/3
# of Shelves	1	2	2	3

SKIPIO UNDERCOUNTER REFERENCE



DISPLAY PRODUCT

REACH-IN

UNDER COUNTER

ICE MAKER

SPECIAL MODEL

BAKING LINE

DISH WASHER



ICE MAKER

OPTIONAL - ICE CUBE SCOOP



CUBE SIZE

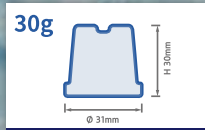

SUPER CUBE

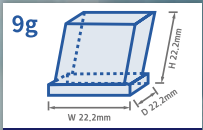

CUBE ICE

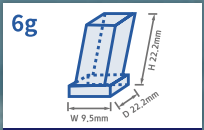

HALF CUBE ICE

SKIPIO

ICE MAKER

- AIR COOLING
- WATER COOLING



SIM-300A
SIM-300W

kg/day
300KG



SIM-200A
SIM-200W

kg/day
200KG

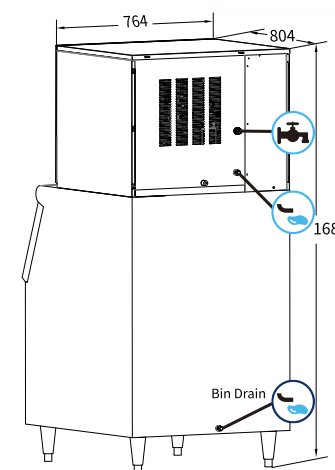

SIM-300A

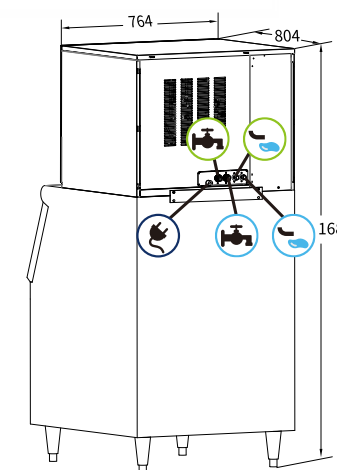

SIM-300W

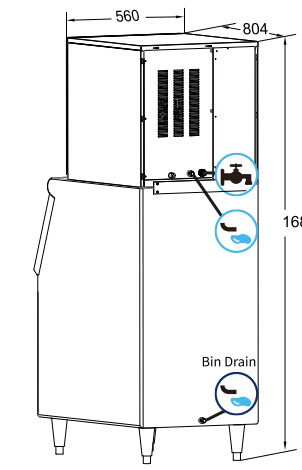

SIM-200A

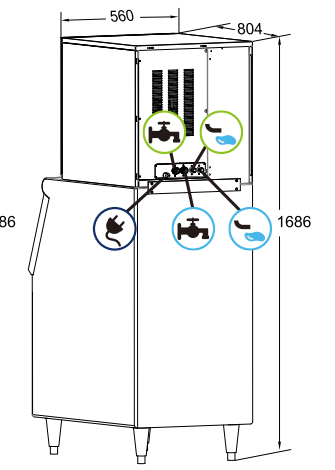

SIM-200W

DISPLAY PRODUCT

REACH-IN

UNDER COUNTER

ICE MAKER

SPECIAL MODEL

BAKING LINE

DISH WASHER

ICE MAKER

- AIR COOLING
- WATER COOLING
- Digital
- LED lamp

SIM-100A
kg/day
100KG

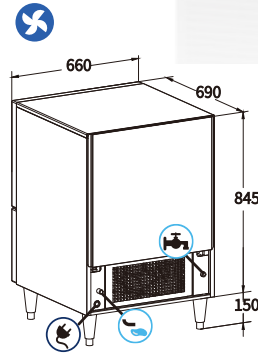

SIM-100NA
SIM-100NW
kg/day
100KG

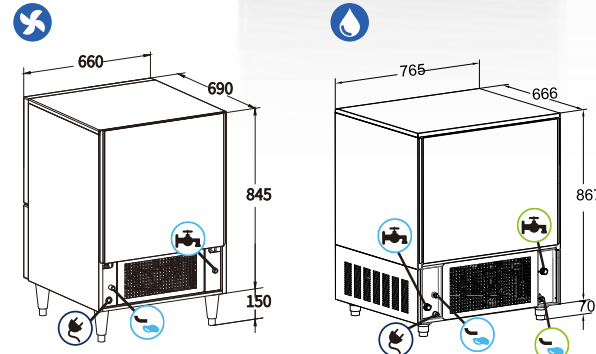

SIM-75A
SIM-75NA
SIM-75NW
kg/day
75KG

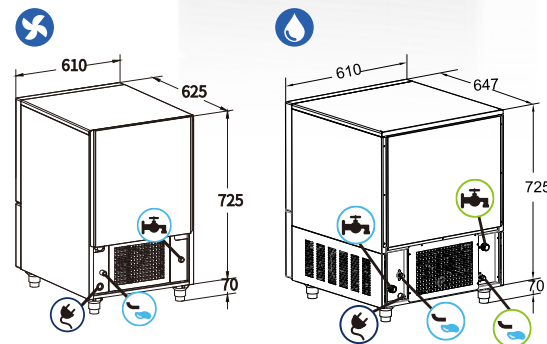

SIM-50A
SIM-50NA
SIM-50NW
kg/day
50KG

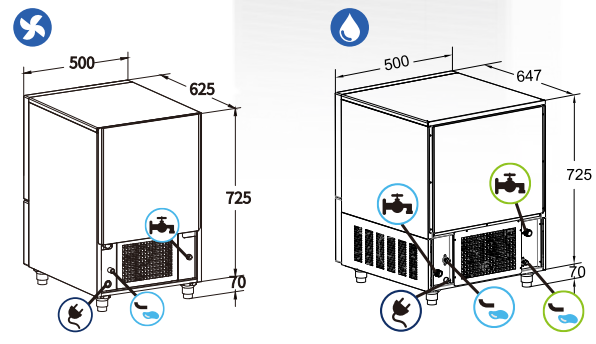

For ice production

- Water Inlet (3/8" FPT)
Hose Joint (3/4" FPT)
- Drain Outlet (ø20)

For condenser cooling

- Water Inlet (3/8" FPT)
Hose Joint (3/4" FPT)
- Drain Outlet (ø20)

For power

- Power cord

Air Cooled

MODEL	SIM-300A	SIM-200A	SIM-100A SIM-100NA	SIM-75A SIM-75NA	SIM-50A SIM-50NA
Shape of Ice	CUBE ICE (9g) / HALF CUBE ICE (6g) SUPER CUBE (30g)				
Cabinet dimension (WxDxH mm)	764 x 804 x 1708	560 x 804 x 1708	660 x 690 x 995 765 x 666 x 937	610 x 625 x 795 610 x 647 x 795	500 x 625 x 795 500 x 647 x 795
Approximate Ice Production (kg / day)	300	200	100	75	50
Bin capacity (kg)	245	200	70	45	25
Refrigerant (R-404a)	550g	450g	350g 350g	300g 280g	250g 230g
Compressor (Hp)	1.1/2	1/2	1/2	1/3	1/3
Cooling Type	Air Cooled				
Insulation Type	Polyurethane / Cyclopentane + CFC Free				
Amps (A)	6	5	4	3.5	2.2
Voltage (V/Hz/Ph)	220 / 50 / 1	220 / 50 / 1	220 / 50 / 1	220 / 50 / 1	220 / 50 / 1
Power (W)	1200	800	580	380	300
Weight (Kg)	89	75	65 68	62 48	58 44
Door type	Swing door	Swing door	Sliding door	Sliding door	Sliding door

Water Cooled

MODEL	SIM-300W	SIM-200W	SIM-100NW	SIM-75NW	SIM-50NW
Shape of Ice	CUBE ICE (9g) / HALF CUBE ICE (6g) SUPER CUBE (30g)				
Cabinet dimension (WxDxH mm)	764 x 804 x 1708	560 x 804 x 1708	765 x 666 x 937	610 x 647 x 795	500 x 647 x 795
Approximate Ice Production (kg / day)	300	200	100	75	50
Bin capacity (kg)	245	200	70	45	25
Refrigerant (R-404a)	550g	450g	350g	280g	230g
Compressor (Hp)	1.1/2	1/2	1/2	1/3	1/3
Cooling Type	Water Cooled				
Insulation Type	Polyurethane / Cyclopentane + CFC Free				
Amps (A)	5	4	4	3.5	3.5
Voltage (V/Hz/Ph)	220 / 50 / 1	220 / 50 / 1	220 / 50 / 1	220 / 50 / 1	220 / 50 / 1
Power (W)	1200	800	580	380	300
Weight (Kg)	54	70	68	48	44
Door type	Swing door	Swing door	Sliding door	Sliding door	Sliding door



SPECIAL MODEL

CHEF BASE
 BACK MOUNTED UNDER COUNTER
 BAR LINE
 MOBILE CART

SKIPIO

CHEF BASE

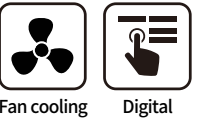

SCB14-4



SCB10-2



SCB18-6

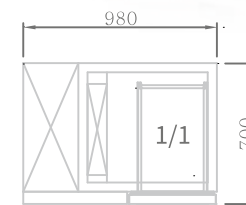

SCB10-2

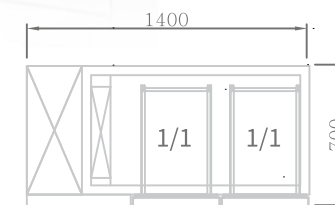

SCB14-4

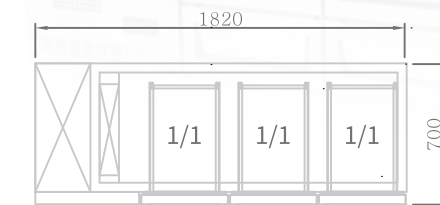

SCB18-6

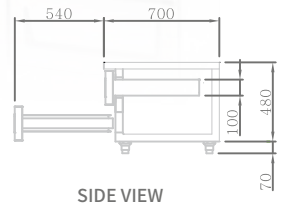

SIDE VIEW

MODEL	SCB10-2	SCB14-4	SCB18-6
Classification	Refrigerator		
Cabinet dimension (WxDxH mm)	980 / 1400 / 1820 x 700 x 550		
Capacity (ℓ)	85	176	267
Inner Temperature (°C)	-2~8		
Refrigerant	R-134a	R-134a	R-134a
Insulation Type	Polyurethane / Cyclopentane + CFC Free		
Amps (A)	2.5	2.5	3.2
Voltage (V/Hz/Ph)	220 / 50 / 1		
Weight (Kg)	90	107	137
Power(W)	239	246	257
# of Drawers	2	4	6
Compressor (HP)	1/4	1/3	3/4

DISPLAY PRODUCT

REACH-IN

UNDER COUNTER

ICE MAKER

SPECIAL MODEL

BAKING LINE

DISH WASHER

BACK MOUNTED UNDER COUNTER

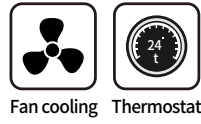

AUR-28(L)
AUF-28(L)

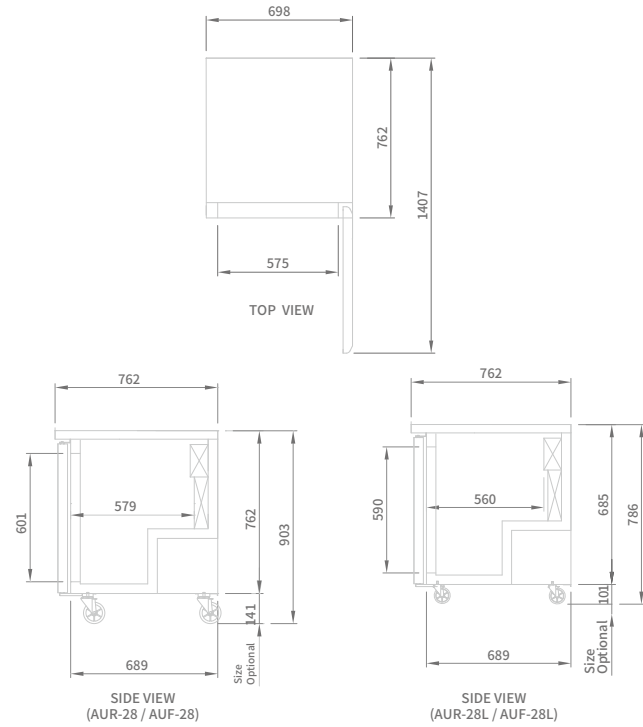

AST-28

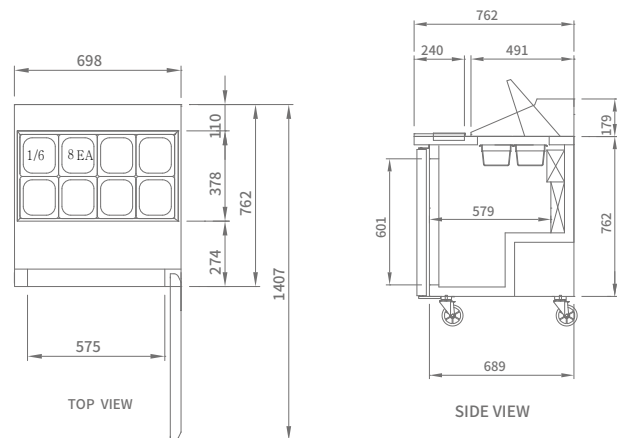

MODEL	AUR-28 AUF-28	AUR-28L AUF-28L	AST-28
Classification		Refrigerator / Freezer	
Cabinet dimension (WxDxH mm)	698x 762 x 903	698x 762 x 786	698x 762 x 1082
Capacity (ℓ)		184	
Inner Temperature (°C)	1~ 8 / -25 ~ -17	1~ 8 / -25 ~ -17	1~ 8
Refrigerant	R-134a / R-134a	R-134a / R-134a	R-134a
Insulation Type		Polyurethane / Cyclopentane + CFC Free	
Amps (A)	2.8/3	2.8/3	2.5
Voltage (V/Hz/Ph)		220 / 50 / 1	
Weight (Kg)	85	85	90
Power (W)	314	314	314
# of doors	4/6	4/6	1
Compressor (HP)	1/4 1/3	1/4 1/3	1/4



BAR LINE



SKIPIO

BAR LINE



SUB16-3

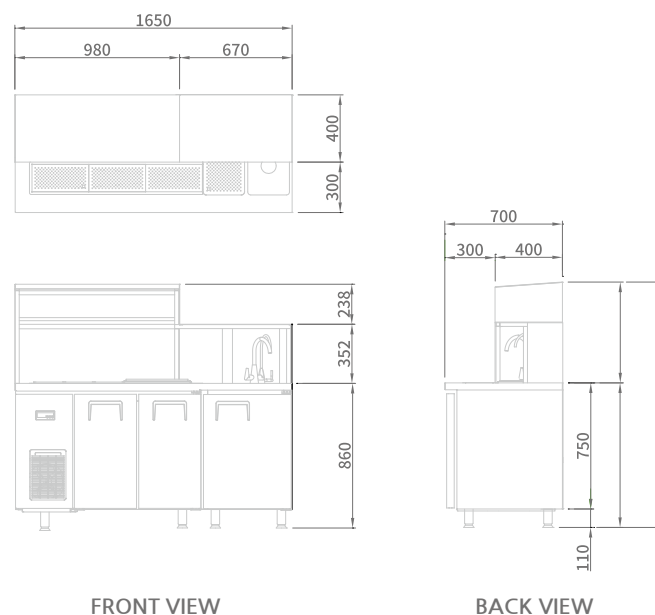

FRONT VIEW

BACK VIEW

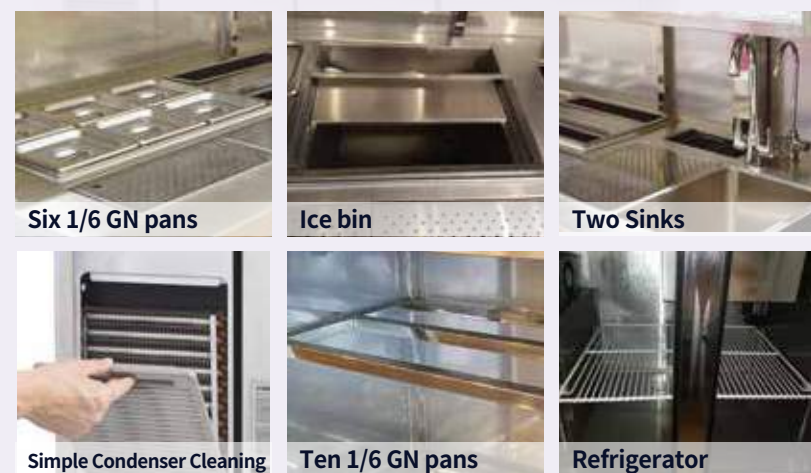

Refrigerator, Ice bin, sinks-
A multifunctional product which can bring all of these together in one place.

Three-in-one

Refrigerator, Ice storage, Sink in one product improve the usage space in the greatest degree.

More flexible

According to the customer request to change the space allocation, flexible and changeable

MODEL	SUB16-3
Classification	Refrigerator
Cabinet dimension (WxDxH mm)	1650 x 700 x 1460
Capacity (ℓ)	270
Inner Temperature (°C)	3 ~ 8
Refrigerant	R-134a
# of Doors	3
Insulation Type	Polyurethane / Cyclopentane + CFC Free
Amps (A)	2
Voltage (V/Hz/Ph)	220 / 50 / 1
Power (W)	350
Weight (Kg)	100
Compressor (HP)	1/3

CART

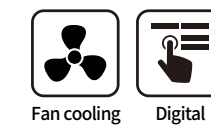

SCR-23D

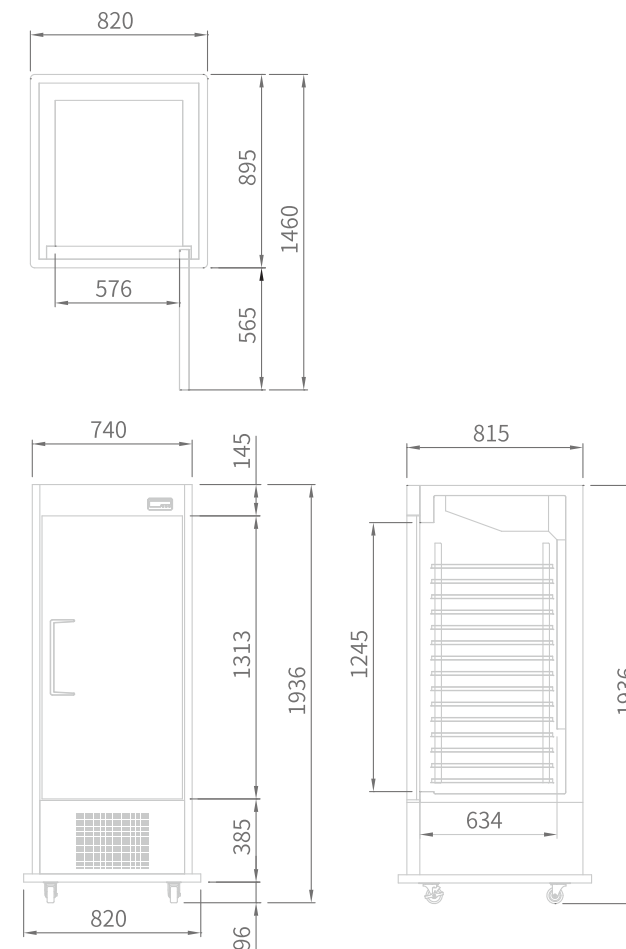

MODEL	SCR-23D
Classification	Refrigerator
Cabinet dimension (WxDxH mm)	820 x 895 x 1936
Capacity (ℓ)	580
Inner Temperature (°C)	3 ~ 8
Refrigerant	R-134a
# of Doors	1
# of Shelves	GN GUIDE RH: 14EA / LF: 14EA
Insulation Type	Polyurethane / Cyclopentane + CFC Free
Amps (A)	2.3
Voltage (V/Hz/Ph)	220 / 50 / 1
Power (W)	400
Weight (Kg)	250
Compressor (HP)	1/3

DISPLAY PRODUCT REACH-IN UNDER COUNTER ICE MAKER SPECIAL MODEL BAKING LINE DISH WASHER

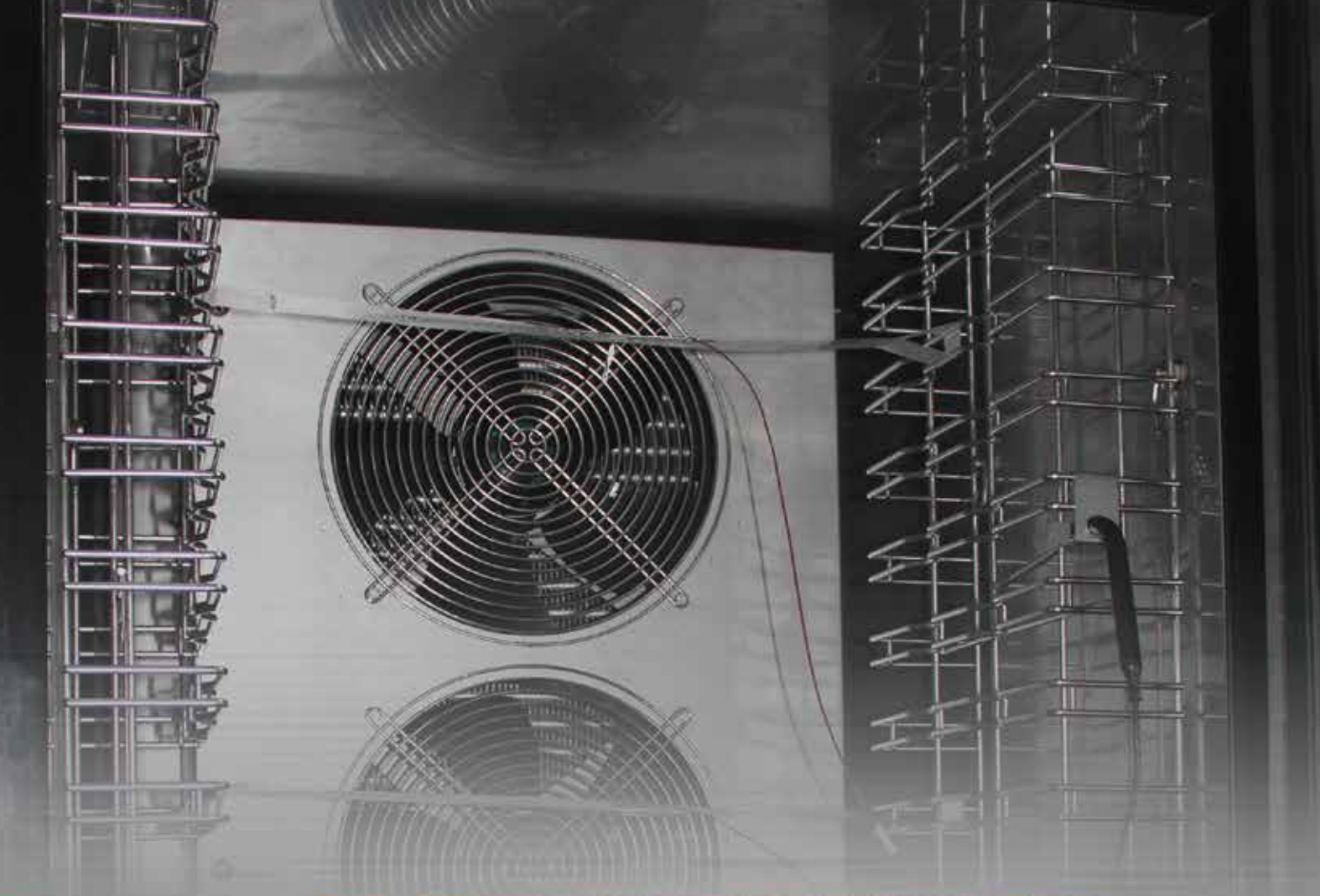

BLAST FREEZER

SOFT CHILLING
+3°

HARD CHILLING
+3°^{HARD}

SHOCK FREEZING
-18°

BLAST FREEZER

STF-16

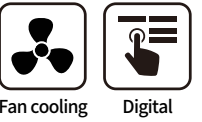

Cryogenic Power Colling for cooked food and ingredients **faster!**



Mode	Core temperature of the food
+3° Soft Chilling	From 90°C to 3°C within 90 minutes
+3° ^{HARD} Hard Chilling	From 90°C to -20°C and stay at 3°C within 90 minutes
-18° Shock Freezing	From 90°C to -18°C within 240 minutes

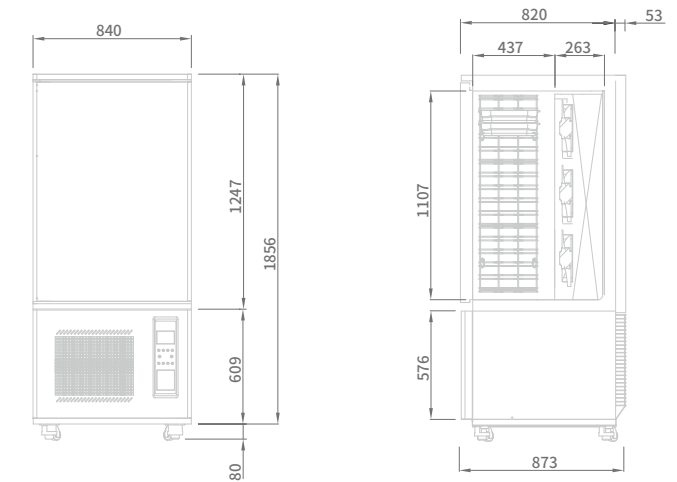

MODEL	STF-16
Classification	Freezer
Cabinet dimension (WxDxH mm)	840 x 875 x 1988
Mode	Soft Chilling From 90°C to 3°C within 90 minutes
(core temperature of the food/ mins required)	Hard Chilling From 90°C to -20°C and stay at 3°C within 90 minutes
	Shock Freezing From 90°C to -18°C within 240 minutes
Capacity (kg)	40
# of doors	1
# of Shelves	Guide Type 2ea (GN/Bun pan 15 Trays)
Insulation Type	Polyurethane / Cyclopentane + CFC Free
Amps (A)	5
Voltage (V/Hz/Ph)	380 / 50 / 3
Power (W)	3290
Weight (Kg)	250
Compressor (HP)	3

DISPLAY PRODUCT

REACH-IN

UNDER COUNTER

ICE MAKER

SPECIAL MODEL

BAKING LINE

DISH WASHER



BAKING LINE

DOUGH REFRIGERATOR / FREEZER

DOUGH CONDITIONER

DECK OVEN

CONVECTION OVEN

MICROWAVE OVEN



SKIPIO

DOUGH REFRIGERATOR / FREEZER



SDR-36-2
SDF-36-2

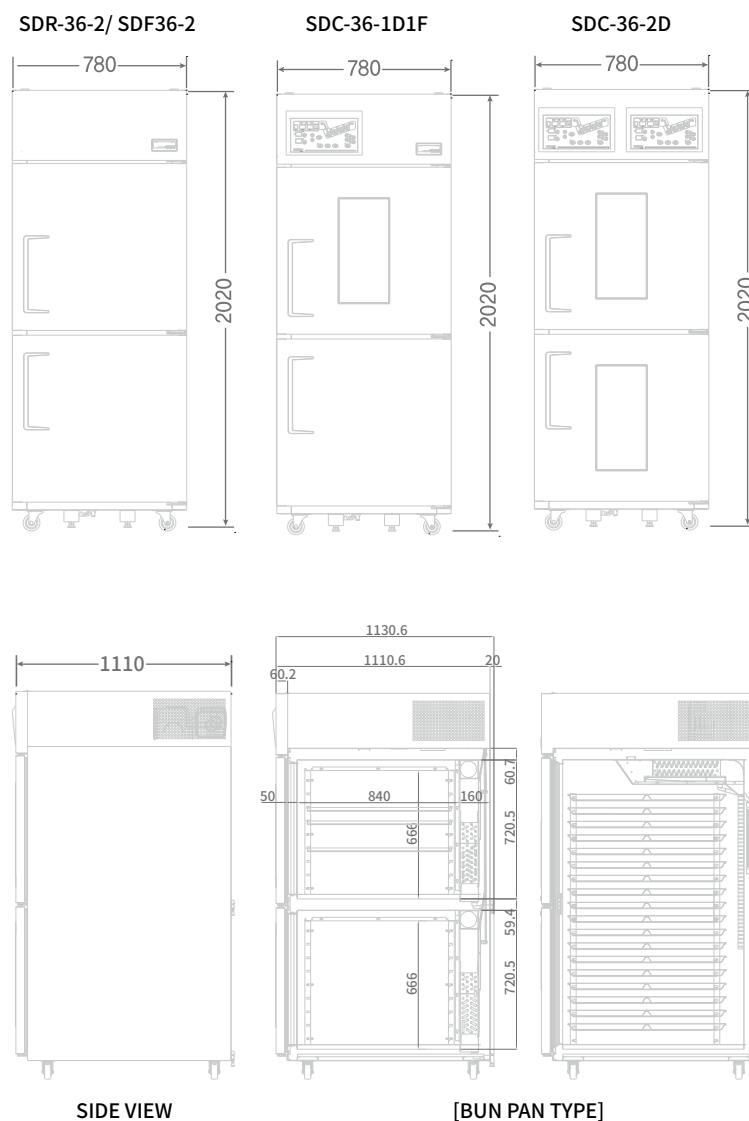

MODEL	SDR-36-2	SDF-36-2
Classification	Refrigerator	Freezer
Cabinet dimension (WxDxH mm)	780 x 1120 x 2020	
Capacity (ℓ)	856	856
Inner Temperature (°C)	1 ~ 8	-27 ~ -18
Refrigerant	R-134a	R-404a
Insulation Type	Polyurethane / Cyclopentane + CFC Free	
Amps (A)	2.5	2.7
Voltage (V/Hz/Ph)	220 / 50 / 1	
Power (W)	500	530
Weight (Kg)	220	230
# of doors	2	2
# of Shelves	36 Trays (18x2)	36 Trays (18x2)
Compressor (HP)	1	1

DOUGH CONDITIONER

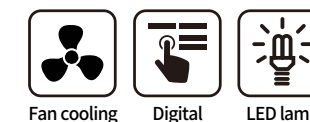

SDC-36-1D1F

SDC-36-2D



The upper and lower rooms are controlled separately which allows users to set different types of conditioning all in one unit.

Four-in-one

Freezer, Defrost, Refrigerator, Proofer in one product improve the usage space in the greatest degree.

More flexible

According to the customer request to change the space allocation, flexible and changeable.

Moisture Care System

Throughout the 4 stages (freezing, defrost, low-temp fermentation, high-temp fermentation), this system maintains moisture and provides optimal conditions for the dough.

User-Centered Design

- Magnetic Doors
- Different indicating lights to show each stage of fermentation.
- Wide Door Windows
- Comfortable door handles

Digital Control System



Easy settings of operating mode, temperature and humidity.

Baking Reservation

Baking reservation can be set a maximum of 4 days in advance. During this process, users can change temperature and humidity for their specific needs.

Interior Design for Air Circulation

The interior is designed to prevent the dough inside from drying out by avoiding direct contact of cold air on the dough.

PWM Proportional Control System

A real time proportional control system that helps maintain temperature and humidity using smart sensors and microprocessors.

MODEL	SDC-36-1D1F	SDC-36-2D
Classification	Proofer + Freezer	Freezer + Proofer
Cabinet dimension (WxDxH mm)	780 x 1120 x 2020	
Capacity (ℓ)	411 / 390	411 x 2
Inner Temperature (°C)	-10~45 / -25~-15	-10 ~ 45
Inner Humidity (%)	30~90	30 ~ 90
Refrigerant	R-134a/ R-134a	R-134a
Insulation Type	Polyurethane / Cyclopentane + CFC Free	
Amps (A)	3.6	3.8
Voltage (V/Hz/Ph)	220 / 50 / 1	
Power (W)	835	848
Weight (Kg)	250	250
# of doors	2	2
# of Shelves	18 Trays / 16 Trays	36 Trays (18x2)

CONVECTION OVEN



SCO5-1

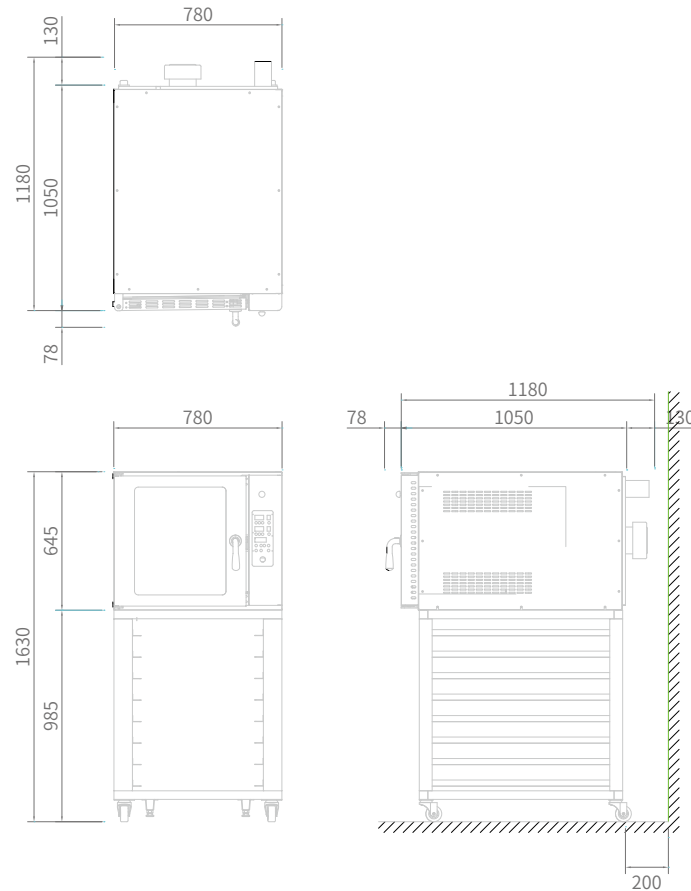

* At least 100mm away from the back the wall

Prestigious Exteroir Design

An exterior design that ts well in open-type kitchen elevating the ambience of the bakery.

Hot Air and Steam

Improved motor and propeller over the existing models gener - ate even ow of air inside the oven to enable even coloriza- tion of product.



Diverse Composition of Lower Siction

Underneath the oven, a proofer for lower sections, 5-tray 2-tier convection oven, 10-tray pro-ducts, etc. can be installed in different combinations.

Various Fuctions

- Precise temperature control
- Menu saving function
- Next-generation operating controller
- Reverse circulation heating function

MODEL	SCO5-1
Classification	Convection Oven
Cabinet dimension (WxDxH mm)	780 x 1180 x 1630
Capacity (ℓ)	5 Trays including lower racks(Bun pan)
Inner Temperature (°C)	0 ~ 270
Lamp	Light Panel
Amps (A)	15
Voltage (V/Ph)	380V / 3Ph / 220V / 2Ph
Power (W)	8Kw / 0.5Kw

DECK OVEN



SDO-33

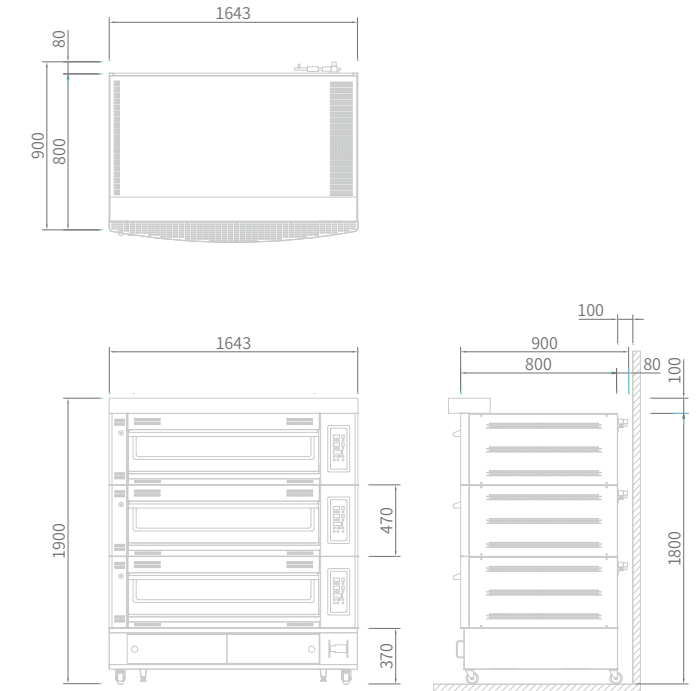

* At least 100mm away from the back the wall

Precise temperature control

A consecutive step-by-step control method with a microprocessor allowing for heating control from 0 ~ 100% to enable even and precise temperature control.

Colorization of the product

A heating system with even heat distribution inside the oven and heat retention ensuring even colourisation of the product.

Free setting

Up to four tiers in line with the baking plan in various combina- tions.



Fine steam

With room-temperature high- pressure steam at micron level, fine system evenly supplied to the bread surface.

MODEL	SDO-33
Classification	Deck Oven
Cabinet dimension (WxDxH mm)	1643 x 900 x 1900
Capacity (ℓ)	5 Trays including lower racks(Bun pan)
Inner Temperature (°C)	0 ~ 270
Lamp	Light Panel
Amps (A)	15
Voltage (V/Ph)	380V / 3Ph / 220V / 2Ph
Power (W)	18Kw / 0.5Kw

MICROWAVE OVEN



SMW-1800HD



MODEL		SMW-1800HD
Cavity volume		27ℓ
Microwave	Power output	1,800W
Dimension (WxDxH)mm	Cavity	371x372x199
	Unit	465x587x370
	Carton	526x636x436
Weight (Net/Gross)		32Kg/34Kg

Main Features

- Program Up to 200 menu items
- Double quantity pad (X2)
- Heat resistant advanced ceramic tray inside
- Easy grip and recessed door handle
- Clean air filter with reminder (10/30/60/90days)
 - 24-hour notice service
 - Conveniently, keep MWO clean
- Clean and sturdy stainless steel exterior
- Easy-to-clean interior

Basic Features

- Control type : digital
- Commercial styling & durability for fast heating and cooking
- 14 touch control pads
- Easy-to-read VFD display
- 60 min cooking timer
- 5 power levels
- 3 stage cook heating option
- Start/20 sec.+ pad for speedy cooking and adding reheat time by 20 sec. increments
- Variable beep tones (Mute mode available)
- Simple one-touch cooking
- Auto cool down after usage
- Auto display off (15sec/30sec/1min/2min)
- Automatically saves the service information
 - usage hours door / opening & closing time, etc
- Tempered glass door with interior light allows monitoring of food
- 2 sets stackable to save the counter space
- Defrost function
- Ideal for quick service and family-style restaurant, fast casual dining



DISH WASHER

UNDER COUNTER TYPE
HOOD TYPE



SKIPIO

DISH WASHER

SDWU-6



SDWH-7
SDWH-7T



Cafe

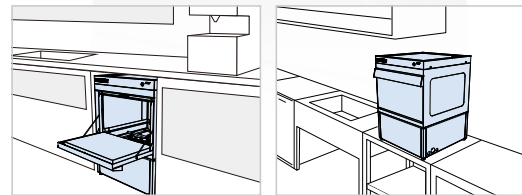

Restaurant

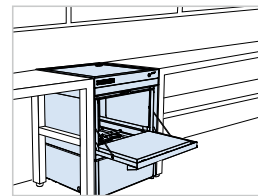

Temperature Range
(International Standard)

- Washing Temperature: 60-65°C
- Rinsing Temperature: 80-86°C

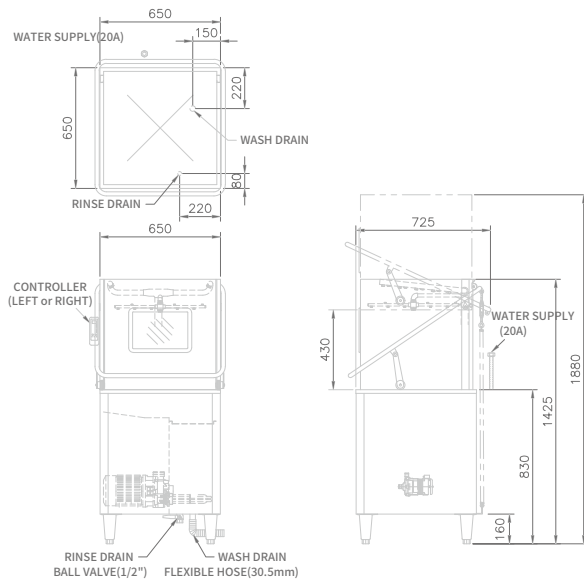

Compact size suitable for limited space like coffee shop, wine bar
Installation availability under table, beside table and on the table.

MODEL	SDWU-6	SDWU-7	SDWH-7T
Cabinet dimension (WxDxH mm)	600 x 600 x 830	650 x 650 x 1355	650 x 650 x 1355
Wash Arm	Spray arm / Spray arm	Fixed and Spray arm / Spray arm	Fixed Nozzle / Rotating Nozzle
Door Clearance (mm)	333	350	350
Weight (Kg)	59	88	88
Voltage (V/Ph)	220 / 1	220 / 1	380 / 3
Power (kW)	4	5.2	5.2
Pump (kW)	Wash	1	1.2
	Rinse	0.13	0.13
Heater (kW)	3	4	8
Tank Capacity (ℓ)	Wash	18	40
	Rinse	8	25
Wash Capacity (Rack/h)	36 - 40	45 - 51	45 - 51
Dispenser	Built-in	Built-in	Built-in



SUPER (S-TYPE) WASH ARM

Patented

Fixed wash arm makes dishes clean from detergent residual. The vane of full cone nozzle and the square washing zone enables water spray to eliminate the blind spot.

Full cone nozzle

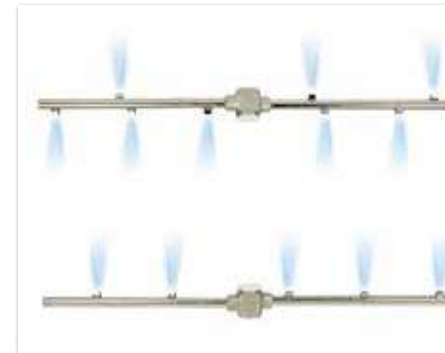
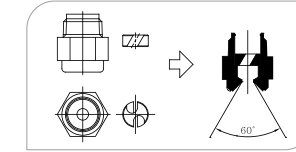

ROOF RINSE NOZZLE

Patented

The up-ward rinse nozzle cleans detergent residual out of hood roof. Thus it prevents re-contamination from detergent dropping on dishes. SKIPIO dishwashing machine is free from re-contamination of detergent after whole washing cycle.

Reagent Test



REMOTE CONTROLLER

Remote controller is not interrupted by installed position even in corner installation. User can read operating stage and upcoming process through FND easily.



BUILT-IN BOOSTER

Provide the effective heat conservation and highly practical space use. It makes operating cost down by reducing thermal losses.



BUILT-IN DISPENSER

Built-in dispenser of detergent and rinse aid, user do not need to install dispenser additionally. The supply quantity is automatically controlled at each stage by MICOM, changeable by remote controller according to food type.



WASH PUMP

Low noise, High-powered pump assures clean and hygienic washing result.



DRAINAGE HOLE

Top cover is usable as sink table with its drainage hole.



EXTRA START SWITCH

Extra start switch on front cover for safety

- STS 304 frame of corrosion resistance
- Visible door window to check working status

GLOBAL REFERENCE

HOTEL



FAST FOOD



ICE CREAM



CAFE & BAKERY



RESTAURANT

