



Electrolux

Saladette Heavy Duty Saladette, 290lt with 2 doors

ITEM # _____

MODEL # _____

NAME # _____

SIS # _____

AIA # _____



Electrolux



Saladette

Heavy Duty Saladette, 290lt with 2 doors

727515 (SAL2D)

2-door refrigerated counter, saladette, -2+10°C, 290lt, AISI 304 (on wheels)

Short Form Specification

Item No. _____

External and internal in AISI 304 stainless steel. Worktop thickness mm50. Insulation thickness mm60. N. 2 full doors. Built-in refrigeration unit. Ventilated operating mode. Electronic control with external digital temperature display. Operating temperature: +2+4°C. For ambient temperature up to +32°C. CF and HCFC free. R404a gas in refrigeration circuit. Gas in foam: Cyclopentane. Supplied with 2X1/1GN grey rilsan grids. Mounted on wheels.

Main Features

- 60 mm insulation for energy saving.
- Anti-tilt runners accept GN 1/1 containers.
- Forced air circulation for rapid cooling and an even temperature distribution.
- Suitable for use in ambient temperatures of up to 32 °C.
- Adjustable temperature range from +2 to +4°C to suit different dairy storage requirements.
- CFC and HCFC free (ecological refrigerant type: R404a, - gas in foam: cyclopentane).
- Integrated refrigerated well compartment for GN 1/3 - Height: 150mm with forced-air circulation and air-curtain.
- No cross-contamination between upper and lower part (nothing will fall in the lower compartment).
- Easy-to-use control panel.
- Electronic control with external digital temperature display.

Construction

- Access to all components from the front.
- Built-in compressor to suit operating conditions.
- Developed and produced in ISO 9001 and ISO 14001 certified factory.
- Mounted on wheels.
- Rounded internal corners for ease of cleaning.
- Worktop in AISI 304 Stainless steel with a 50 mm thickness.
- Constructed from AISI 304 Stainless steel throughout to meet the highest hygiene standards.
- Heavy duty, balanced stainless steel lid, easy to remove and turn to facilitate cleaning.
- Large front working top (400 mm).
- Easy to clean: removable internal support structure with no dirt traps for unbeatable hygiene.
- If needed, working top can be removed for easier handling during installation (in case of narrow doors).

Included Accessories

- 2 of 1/1GN grey rilsan grid PNC 881435

Optional Accessories

- Kit integrated HACCP for digital refrigerators (IR33) PNC 880252
- 1/1GN grey rilsan grid PNC 881435
- Printer for HACCP basic version (digital control) PNC 881457
- Lock for refrigerated counters PNC 881499
- Kit 2 drawers 1/2+rack-HD refrigerated counters - not for freezer version PNC 881514
- Kit 3 drawers 1/3+rack-HD refrigerated counters - not for freezer version PNC 881515
- Kit 1 bottler+1 drawer for refrigerated counters - not for freezer version PNC 881516

APPROVAL: _____



Electrolux

Saladette Heavy Duty Saladette, 290lt with 2 doors

Front

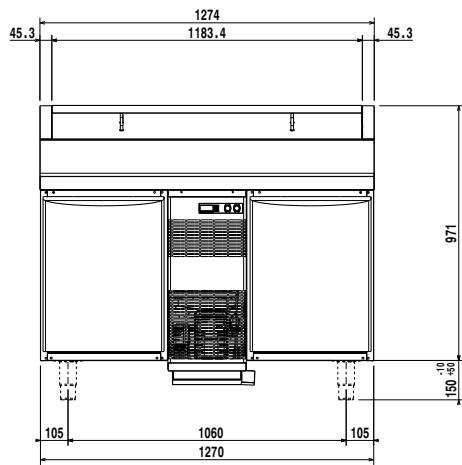

Top

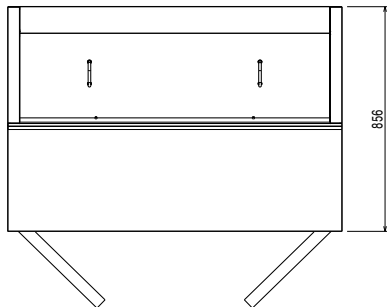

- D = Drain
- = Remote electrical connection
- ED = Electrical connection
- EI = Electrical connection

Side

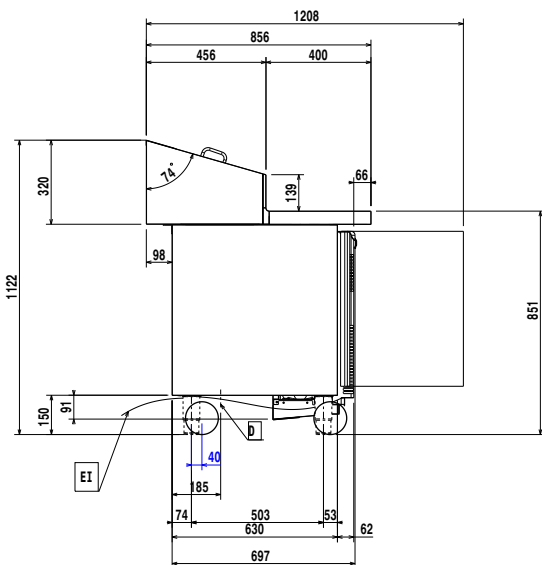

Electric

Supply voltage:

727515 (SAL2D) 230 V/1N ph/50 Hz

Key Information:

Door hinges: 1 Left+1 Right

External dimensions, Height: 1122 mm

External dimensions, Width: 1274 mm

External dimensions, Depth: 856 mm

External dimensions, Depth with Doors Open: 1110 mm

Number and type of doors: 2

Gross capacity: 291 lt

Number and type of grids (included): 2 - GN 1/1

Type of external material: 304 AISI

Type of internal material: 304 AISI

Internal side panels material: 304 AISI

Energy cons. min,max : 0 - 12.07 kW/h

Built-in Compressor and Refrigeration Unit

Refrigeration Data

Compressor power: 3/4 hp

Refrigerant type: R404a

Refrigeration power: 1684 W

Refrigerant weight: 535 g

Operating temperature min.: 2 °C

Operating temperature max.: 4 °C

Saladette
Heavy Duty Saladette, 290lt with 2 doors

The company reserves the right to make modifications to the products without prior notice. All information correct at time of printing.

