



CMUR-28
CMUF-28



CMUR-48
CMUF-48



CMUR-60
CMUF-60



CMUR-72

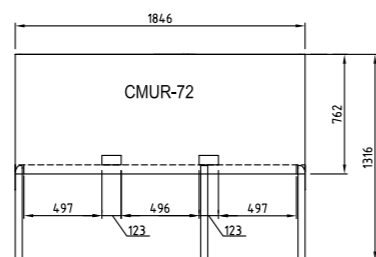
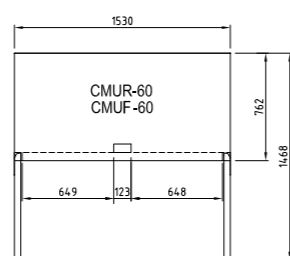
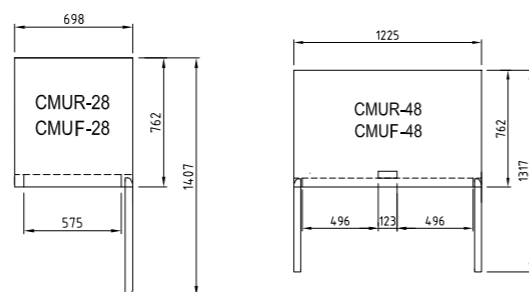
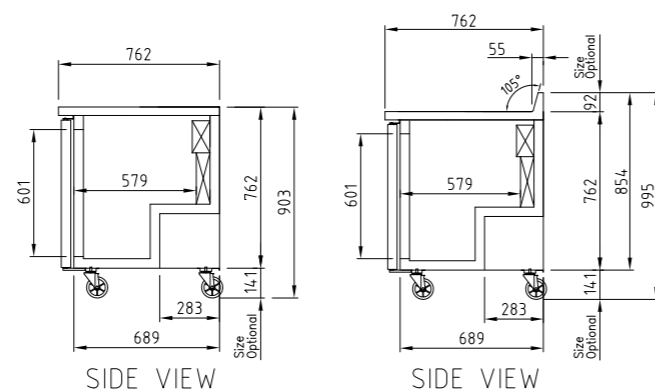

Refrigerator Under Counter/Work Top

Model	CMUR-28	CMUR-48	CMUR-60	CMUR-72
Classification	Refrigerator			
Cabinet dimensions(W*D*H,mm)	698X762X903	1225X762X903	1530X762X903	1846X762X903
Capacity(Liters)	184	340	506	538
Inner Temperature	1°C~8°C			
Doors	1	2	2	3
# of shelves	1	2	2	3
Refrigerant	R-134a	R-134a	R-134a	R-134a
Compressor (Hp)	1/4	1/3	1/3	1/3
Cooling Type	Fan cooling type			
Insulation Type	Polyurethane / Cyclopentane+ CFC Free			
Temperature control type	Thermostat			
Amps(A)	2.8	3.5	3.8	5.3
Voltage (V/Hz/Ph)	220/50/1			
Power (W)	314	366	440	440
Weight (Kg)	85	105	130	160

Freezer Under Counter/Work Top

Model	CMUF-28	CMUF-48	CMUF-60
Classification	Freezer		
Cabinet dimensions(W*D*H,mm)	698X762X903	1225X762X903	1530X762X903
Capacity(Liters)	184	340	506
Inner Temperature	-25°C~-17°C		
Doors	1	2	2
# of shelves	1	2	2
Refrigerant	R-134a	R-404a	R-404a
Compressor (Hp)	1/3	1/2	1/2
Cooling Type	Fan cooling type		
Insulation Type	Polyurethane / Cyclopentane+ CFC Free		
Temperature control type	Thermostat		
Amps(A)	3	4	5.3
Voltage (V/Hz/Ph)	220/50/1		
Power (W)	314	477	477
Weight (Kg)	85	105	135