

DATA SHEET

7 FRAME PLUNGER PUMPS

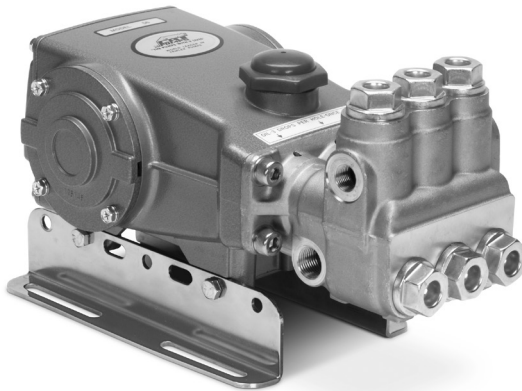

Brass Models: 57, 60
Gearbox Models: 60G1, 60G118



Model 60 Shown
(Rails Sold Separately)

FEATURES

- Industrial triplex design offers reliability and versatility.
- Compact direct-drive mount to motor using bell housing and flexible coupling (Electric - NEMA or IEC, Hydraulic - SAE) available.
- Gearbox model available with 1" and 1-1/8" hollow shaft to fit a wide variety of engines.
- Pre-Set Lo-Pressure Seals provide secondary protection against external leaks and require no packing adjustment.
- Standard NBR seals with alternative options for temperature and chemical compatibility.

COMMON SPECIFICATIONS

	U.S.	Metric
Inlet Pressure Range	Flooded to 60 psi	Flooded to 4.1 bar
Standard Liquid Temp. (NBR)	160° F	71° C
Alternative seals available for high temp up to 190° F		
Bore	0.709"	18 mm
Crankcase Capacity	25 oz.	0.74 l
Inlet Ports (2)	1/2" NPT(F)	1/2" NPT (F)
Discharge Ports (2)	3/8" NPT (F)	3/8" NPT (F)
Shaft Diameter	0.945"	24 mm
Weight	29.25 lbs.	13.3 kg
Weight w/Gearbox	36.8 lbs.	16.7 kg
Dimensions (pump only)	13.94 x 8.19 x 6.42"	354 x 208 x 163 mm
Dimensions (w/gearbox)	13.94 x 10.83 x 6.42"	354 x 275 x 163 mm

SPECIFICATIONS	U.S. Measure	Metric Measure
Model 57		
Flow	4.5 gpm	17 lpm
Pressure Range	100 to 4000 psi	6.9 to 276 bar
Pump RPM*	1285 rpm	1285 rpm
Stroke	0.728"	18.5 mm
Model 60		
Flow	4.7 gpm	17.9 lpm
Pressure Range	100 to 4000 psi	6.9 to 276 bar
Pump RPM*	1750 rpm	1750 rpm
Stroke	0.591"	15 mm
Gearbox Models 60G1, 60G118		
Flow	4.5 gpm	17 lpm
Pressure Range	100 to 4000 psi	6.9 to 276 bar
Engine RPM	3450 rpm	3450 rpm
Stroke	0.591"	15 mm

*Pump minimum is 100 rpm.

ALTERNATIVE SEAL CONFIGURATION

MATERIAL	SUFFIX CODE	MAXIMUM TEMPERATURE
NBR	—	160° F (71° C)
FPM	.0110	180° F (82° C)
EPDM	.0220	160° F (71° C)
HT	.3000	180° F (82° C)
STHT	.3400	190° F (88° C)

See Reference Document 99TCH002 for inlet conditions and RPM at high temperature.

DETERMINING THE PUMP R.P.M.	Rated gpm	=	"Desired" gpm
	Rated rpm	=	"Desired" rpm
DETERMINING THE REQUIRED H.P.	Hp (Electric Brake)	=	gpm x psi 1460
DETERMINING MOTOR PULLEY SIZE	Motor Pulley O.D. Pump rpm	=	Pump Pulley O.D. Motor rpm

Refer to pump **Service Manual** for repair procedure and additional technical information.

PARTS LIST

ITEM					DESCRIPTION	QTY
57	MATL	60/60G1/ 60G118	MATL			
2	30067	STL	30067	STL	Key (M8x7.5x25)	1
5	125824	STCP R	125824	STCP R	Screw, HHC Sems (M6x16)	8
8	133571	ALE	133571	ALE	Cover, Bearing (See Tech Bulletin 118, 123)	1
9	815280	FBR	815280	FBR	Shim, Split, 2-Pc	1
10	12393	NBR	12393	NBR	O-Ring, Bearing Cover	2
11	43222	NBR	43222	NBR	Seal, Oil Crankshaft	1
15	43221	STL	43221	STL	Bearing, Roller	2
20	48863	TNM	48863	TNM	Rod, Connecting [6/02]	3
25	44947	FCM	44591	FCM	Crankshaft, Single End	1
30	133572	ALE	133572	ALE	Cover, Bearing, Blind (See Tech Bulletin 118, 123)	1
31	828710	PE	828710	PE	Protector, Oil Cap w/Foam Gasket	1
32	44666	RTP	44666	RTP	Cap, Oil Filler, Domed-Gearbox Models	1
33	14177	NBR	14177	NBR	O-Ring, Oil Filler Cap - 70D	1
37	92241	PC	92241	PC	Gauge, Oil Bubble w/Gasket - 80D	1
38	44428	NBR	44428	NBR	Gasket, Flat Flex, Oil Gauge - 80D	1
40	126541	STCP R	126541	STCP R	Screw, HHC Sems (M6x20)	4
48	25625	STCP	25625	STCP	Plug, Drain (1/4"x19BSP)	1
49	23170	NBR	23170	NBR	O-Ring, Drain Plug - 70D	1
50	133569	ALE	133569	ALE	Cover, Rear (See Tech Bulletin 118, 123)	1
51	14047	NBR	14047	NBR	O-Ring, Rear Cover (See Tech Bulletin 106)	1
53	133593	ALE	133593	ALE	Crankcase (See Tech Bulletin 118, 123)	1
56	43240	POP	43240	POP	Pan, Oil	1
64	43237	CM	43237	CM	Pin, Crosshead	3
65	48913	SHS	48913	SHS	Rod, Plunger, Short [5/02]	3
69	126589	STCP R	126589	STCP R	Washer, Oil Seal	3
70	43228	NBR	43228	NBR	Seal, Oil, Crankcase	3
75	43328	S	43328	S	Slinger, Barrier	3
88	45697	S	45697	S	Washer, Keyhole (M18 x M10)	3
90	43232	CC	43232	CC	Plunger (M18x77)	3
95	126559	STCP R	126559	STCP R	Stud, Plunger Retainer (M6x70)	3
96	43235	PTFE	43235	PTFE	Back-up-Ring, Plunger Retainer	3
97	17399	NBR	17399	NBR	O-Ring, Plunger Retainer - 80D	3
	14160	FPM	14160	FPM	O-Ring, Plunger Retainer - 80D	3
98	45891	CU	45891	CU	Gasket, Plunger Retainer	3
99	46504	S	46504	S	Retainer, Plunger (M6)	3
100	45689	PVDF	45689	PVDF	Retainer, Seal, 2pc (See Tech Bulletin 105)	3
101	43239	FBR	43239	FBR	Wick, Long Tab	3
106	43243	NBR	43243	NBR	Seal, LPS w/S-Spg	3
	44926	FPM	44926	FPM	Seal, LPS w/SS-Spg	3
	76243	ST2	76243	ST2	Seal, LPS w/S-Spg	3
120	45685	BB	45685	BB	Case, Seal	3
121	20285	NBR	20285	NBR	O-Ring, Seal Case - 70D	3
	11693	FPM	11693	FPM	O-Ring, Seal Case	3
126	44550	BB	44550	BB	Adapter, Female	3
127	44549	SNG	44549	SNG	V-Packing	6
	45617	SFG	45617	SFG	V-Packing	6
	48300	STG	48300	STG	V-Packing	6
128	45618	BB	45618	BB	Adapter, Male	3
139	43448	BB	43448	BB	Plug, Inlet, [1/2" NPT(M)]	1
162	43248	PTFE	43248	PTFE	Back-up-Ring, Seat	6
163	43249	NBR	43249	NBR	O-Ring, Seat - 80D	6
	44383	FPM	44383	FPM	O-Ring, Seat - 70D	6
164	43722	S	43722	S	Seat	6
166	43721	S	43721	S	Valve	6
167	43751	S	43751	S	Spring	6
168	44564	PVDF	44564	PVDF	Retainer, Spring	6
172	14179	NBR	14179	NBR	O-Ring, Valve Plug - 70D	6
	15855	FPM	15855	FPM	O-Ring, Valve Plug - 70D	6
173	20213	PTFE	20213	PTFE	Back-up-Ring, Valve Plug	6
174	45939	BB	45939	BB	Plug, Valve, Extended	6
185	45937	FBB	45937	FBB	Head, Manifold, (M10)	1
186	49680	S	49680	S	Washer, Spring (M10)	4
188	49679	S	49679	S	Screw, HSH (M10x35)	4
255	30243	STZP	30243	STZP	Kit, Direct Mount	1
260	30611	STZP R	30611	STZP R	Assy, Angle Rail, B (2.09" x 9.45") Standard	1
	30645	STZP R	30645	STZP R	Assy, Angle Rail, A (2.95" x 11.81")	1
283	34334	—	34334	—	Kit, Oil Drain (3/8" x 24")	1
299	814618	FBB	814618	FBB	Head, Complete w/NBR Seals and O-Rings	1

EXPLODED VIEW

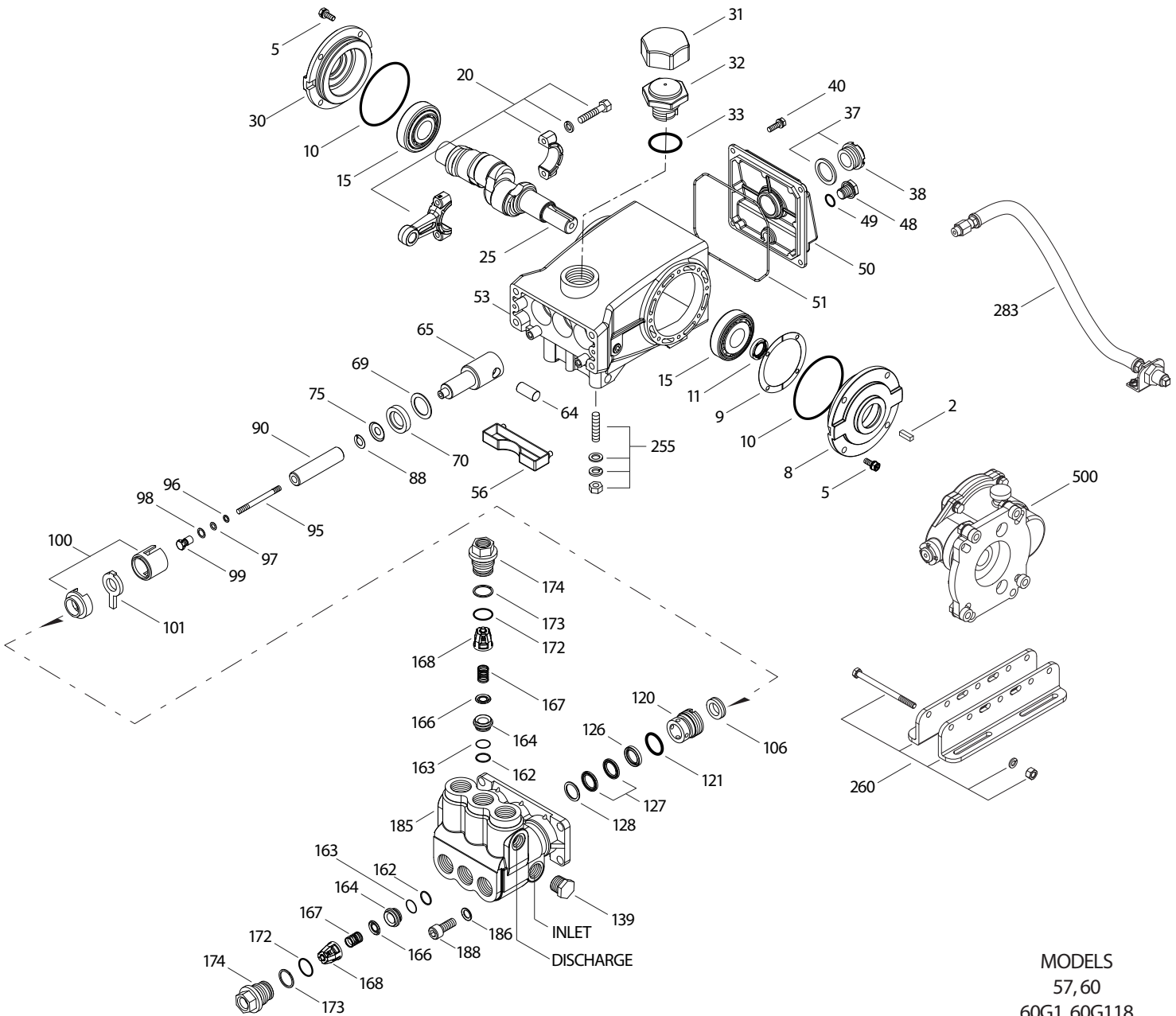

MODELS
57,60
60G1,60G118
February 2020

ITEM					DESCRIPTION	QTY
	57	MATL	60/60G1/ 60G118	MATL		
300	30799	NBR	30799	NBR	<i>Kit, Seal (Incls: 97,101,106,121,127) – Standard</i>	1
	34237	FPM	34237	FPM	<i>Kit, Seal (Incls: 97,101,106,121,127) – .0110</i>	1
	76799	HT	76799	HT	<i>Kit, Seal, "High Temp" (Incls: 97,101,106,121,127) – .3000</i>	1
	76826	STHT	76826	STHT	<i>Kit, Seal, (Incls: 97,101,106,121,127) – .3400</i>	1
310	33820	NBR	33820	NBR	<i>Kit, Valve (Incls: 162-168,172,173) – Standard, .3000, .3400</i>	2
	34238	FPM	34238	FPM	<i>Kit, Valve (Incls: 162-168,172,173) – .0110</i>	2
500	—	—	8071	—	<i>Gearbox-1" Shaft (See individual Data Sheet) – 60G1</i>	1
	—	—	8078	—	<i>Gearbox-1-1/8" Shaft (See individual Data Sheet) – 60G118</i>	1
—	6107	—	6107	—	<i>Oil, Bottle (21 oz.) ISO 68 Hydraulic (Fill to specified crankcase capacity prior to start-up)</i>	1-2

Bold print part numbers are unique to a particular pump model. *Italics are optional items.* [] Date of latest production change.

R Components comply with RoHS Directive. For additional technical information see www.catpumps.com/literature/tech-bulletins.

MATERIAL CODES (Not Part of Part Number): ALE=Aluminum Epoxy BB=Brass CC=Ceramic CM=Chrome-Moly CU=Copper FBB=Forged Brass
FBR=Fiber FCM=Forged Chrome-Moly FPM=Fluorocarbon HT=High Temp NBR=Medium Nitrile (Buna-N) PE=Polyethylene POP=Polypropylene
PC=Poly Carbonate PTFE=Pure Polytetrafluoroethylene PVDF=Polyvinylidene Fluoride RTP=Reinforced Composite S=304SS SFG=Special Blend FPM
SHS=304SS/High Strength SNG=Special Blend (Buna) STCP=Steel/Chrome Plated STG=Special Blend PTFE White STHT=Special PTFE High Strength
STL=Steel STZP=Steel/Zinc Plated TNM=Special High Strength

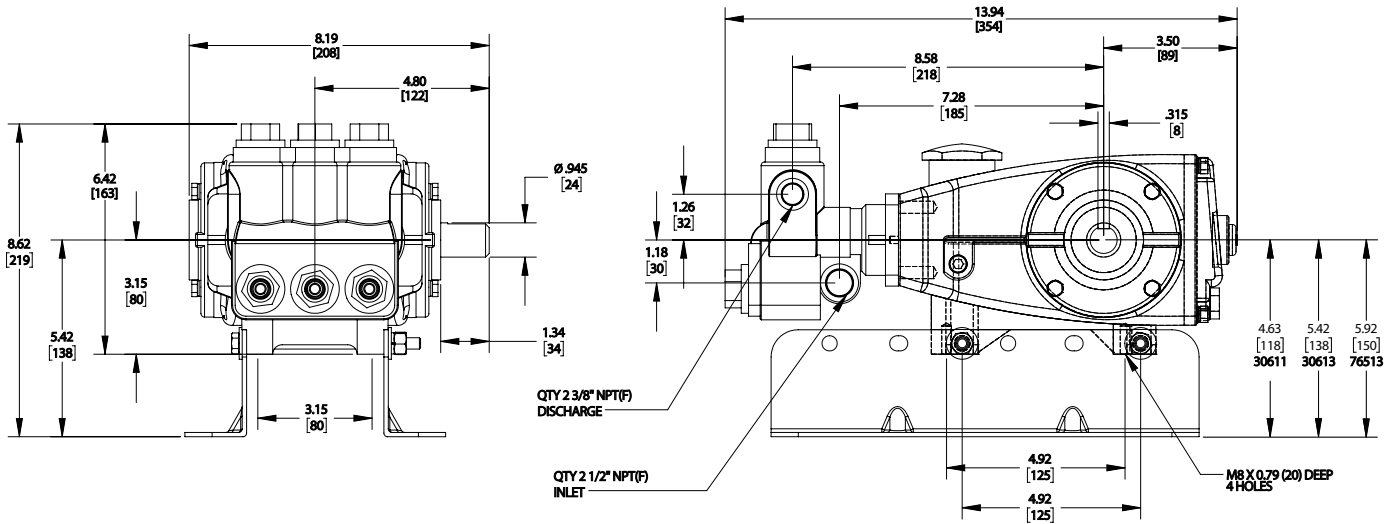

Models 57, 60

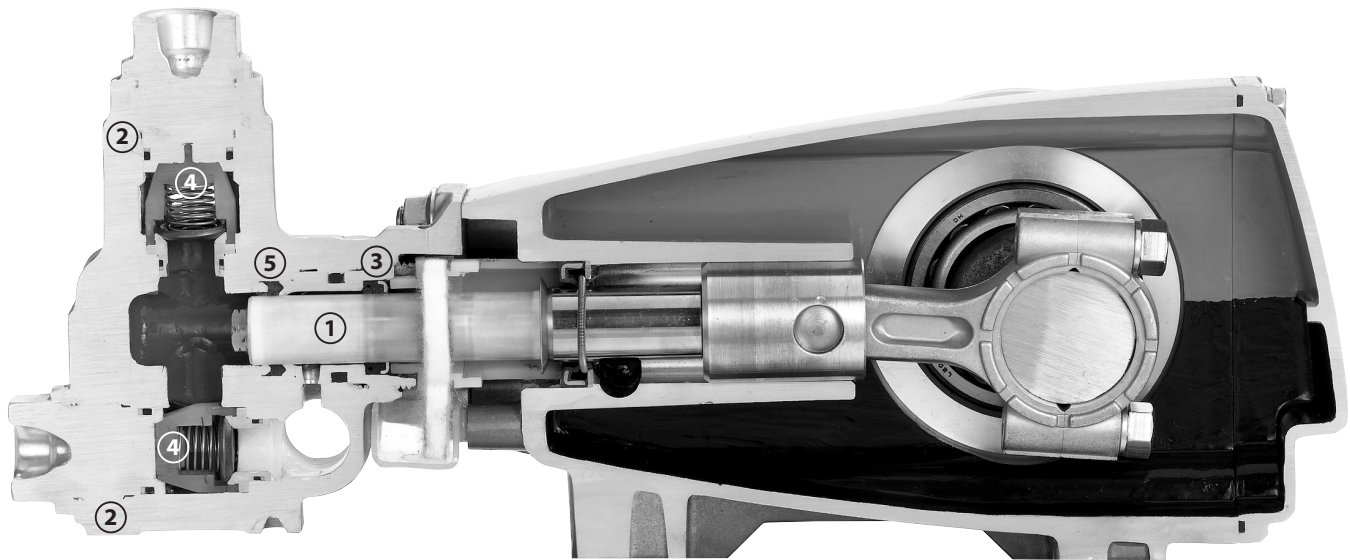

- 1 Special concentric, high density, polished, solid ceramic plungers provide a true wear surface and extended seal life.
- 2 Manifolds are a high tensile strength bronze for long term, continuous duty and corrosion resistance.
- 3 100% wet seal design adds to service life by allowing pumped liquids to cool and lubricate on both sides.
- 4 Stainless steel valves, seats and springs provide corrosion-resistance, ultimate seating and extended life.
- 5 Specially formulated, Cat Pump exclusive, V-Packing offer unmatched performance and seal life.

CAUTIONS AND WARNINGS

All High-Pressure Systems require a primary pressure regulating device (i.e. regulator, unloader) and a secondary pressure relief device (i.e. pop-off valve, relief valve). Failure to install such relief devices could result in personal injury or damage to pump or property. Cat Pumps does not assume any liability or responsibility for the operation of a customer's high-pressure system. Read all CAUTIONS and WARNINGS before commencing service or operation of any high-pressure system. The CAUTIONS and WARNINGS are included in each service manual and with each Accessory Data Sheet. CAUTIONS and WARNINGS can also be viewed online at www.catpumps.com/cautions-warnings or can be requested directly from Cat Pumps.

WARRANTY

View the Limited Warranty on-line at www.catpumps.com/warranty.



PIJTTERSEN

Pijtersen B.V.
Beneluxweg 33
9636 HV Zuidbroek
Tel.: +31(0)50-8200963

KvK 01013855
BIC RABONL2U
BTW NL002166811B01
IBAN NL24 RABO 0353 2970 97

www.pijtersen.nl - info@pijtersen.nl | www.catpumps.nl - info@catpumps.nl



The Pumps with Nine Lives