

SERVICE MANUAL

15 & 25 FRAME PLUNGER PUMPS

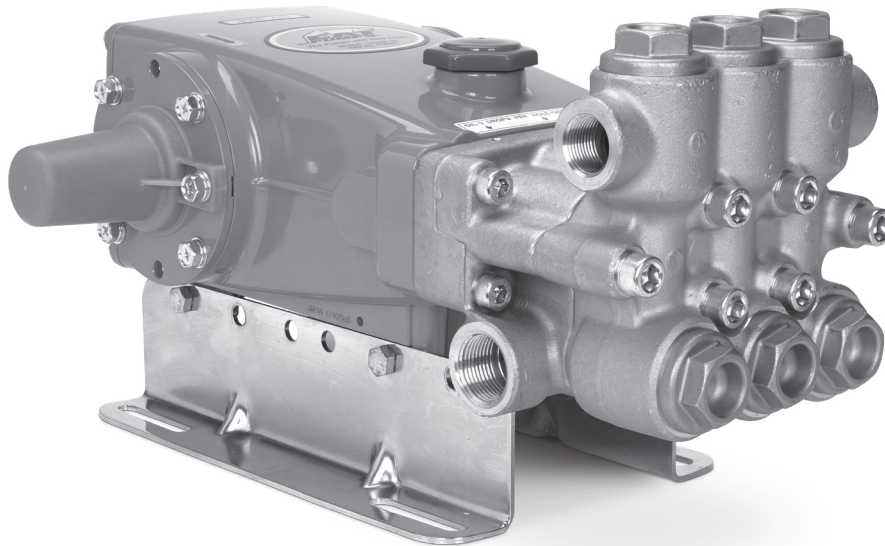

PUMP MODELS INCLUDED

1530	1531	1540	1540E	1560	1580
2510	2511				

	PIJTTERSEN Email : info@pijtersen.nl / info@catpumps.nl Internet : www.pijtersen.nl / www.catpumps.nl
---	--

Product Quality, Reliability and Support You Expect

www.catpumps.nl

Table of Contents

Safety Symbols	2
General Safety Information	3
Servicing the Seals	6
Discharge Manifold Removal	6
Inlet Manifold Removal	6
Seal Disassembly	6
Seal Reassembly	6
Servicing the Plungers	7
Plunger Disassembly	7
Plunger Reassembly	7
Servicing the Valves	8
Valves Disassembly	8
Valves Reassembly	8
Servicing the Crankcase	9
Reference Information	10
Torque Chart	10
Technical Bulletin Reference Chart	10
Torque Sequences	10
Preventive Maintenance Schedule	11
Diagnosis and Maintenance	12

Safety Symbols

IMPORTANT SAFETY INSTRUCTIONS

It is the responsibility of the user to read and understand all instructions, important safeguards and safety precautions before operating or servicing any pump. Failure to do so may result in property damage, personal injury or death.

GENERAL SAFETY INFORMATION AND SYMBOLS

Pay special attention to the following signal words, safety alert symbols and statements:



DANGER

Indicates a hazardous situation which, if not avoided, will result in death or serious injury.



WARNING

Indicates a hazardous situation which, if not avoided, could result in death or serious injury.



CAUTION

Indicates a hazardous situation which, if not avoided, could result in minor or moderate injury or property damage.



NOTICE

Indicates a hazardous situation which, if not avoided, could result in property damage.



Indicates a potential personal injury hazard. Obey all safety messages that follow this symbol to avoid possible injury or death.

General Safety Information

⚠ DANGER

A. FLAMMABLE OR EXPLOSIVE LIQUID HAZARD

Do not operate pump with flammable or explosive liquids unless extraordinary safety precautions are observed. Leaks of flammable or explosive liquids, if exposed to elevated temperatures, static electricity, sparks or other hazards, will result in flame or possible explosion, causing serious personal injury, death or property damage.

1. Before operating pump with flammable or explosive liquids, ensure proper maintenance has been performed.
 2. Do not operate pump with flammable or explosive liquids if leaks are detected.
 3. Only pump flammable or explosive liquids that are compatible with pump component materials.
 4. Do not operate pump with flammable or explosive liquids without safeguards or safety systems to detect leaks, elevated temperatures, spark prevention or any other hazards defined by the NFPA systems.
 5. Do not remove Flammable Liquids Product Suitability Hang Tag to assure proper safety.
 6. Follow ATEX guidelines for potentially-explosive atmospheres.
-

⚠ WARNING

A. ELECTRICAL SHOCK HAZARD

Do not service pump or electrical equipment while energized. Electricity can cause personal injury, death or property damage.

1. Adhere to "Lock Out" and "Tag Out" procedures for electrical equipment.
2. Before commencing pump service, turn power supply off.
3. Keep water away from electrical outlets and electrical devices.
4. Electrical components must be installed by a qualified electrician to avoid risk of electrocution.

B. ROTATING PARTS HAZARD

Do not service pump while energized. Moving, rotating or reciprocating parts can crush and cut, causing personal injury, death or property damage.

1. Adhere to "Lock Out" and "Tag Out" procedures for electrical equipment.
2. Before commencing pump service, turn power supply off, turn water supply off, squeeze trigger on gun to relieve system pressure.
3. For mobile equipment, be sure engines and hydraulics are turned off and secured to avoid accidental start.
4. Do not operate with safety guards removed.
5. Always use safety guards on all belt drives, couplings and shafts.

C. HOT SURFACE HAZARD

Do not touch pump, accessories or drive system while operating and until cool down is complete. Touching hot surface areas of the pump, accessories or drive system can cause severe burns or personal injury.

D. SKIN PUNCTURE HAZARD

Do not allow spray to contact any part of the body or animals. Pumped liquids under high pressure can pierce skin and underlying tissue or can deflect debris leading to serious personal injury or death.

1. Relieve all line pressure in the inlet line to the pump and discharge line from the pump before performing any maintenance on the pump.
2. When a high-pressure gun is not in use, set safety trigger lock (safety latch) to avoid accidental high-pressure operation and personal injury or property damage.
3. Do not check for leaks with hand. Use a piece of cardboard to check for leaks.
4. Review cleaning procedures to minimize heavy back blasting.
5. Wear adequate safety equipment and clothing when operating a high-pressure sprayer. Never use high-pressure spray with bare feet or exposed skin, and always wear safety glasses.

E. PUMPING LIQUIDS HAZARD

Do not operate pump with hot water, chemicals or other hazardous liquids unless extraordinary safety precautions are observed. Pumping hot water, chemicals or other hazardous liquids can expose personnel to serious injury.

1. Provide guards or shields around equipment to protect personnel.
2. Wear mask, goggles or eye protection while operating high-pressure equipment.
3. Obtain a Safety Data Sheet (SDS) and take appropriate safety measures for the liquid being handled.

General Safety Information and Symbols

F. OVER PRESSURIZATION HAZARD CONTINUED

Do not operate high-pressure pumping system unless extraordinary safety precautions are observed. A high-pressure pumping system can deadhead or over pressurize causing serious personal injury and property damage.

1. All high-pressure systems require a primary pressure regulating device (e.g., regulator or unloader) and a secondary pressure safety relief device (e.g., pop-off valve, safety valve, rupture disc) to assure proper pressure setting and overpressure protection.
2. All high-pressure systems require a pressure gauge to monitor pressure settings and avoid overpressure of equipment or personal harm.
3. Install primary pressure relief device on the discharge side of the pump.
4. Install secondary pressure relief device between the primary device and pump.
5. Install pressure gauge onto the discharge manifold or in the discharge line near the manifold.
6. Open all valves on discharge side of plumbing before operation.

G. OXYGEN HAZARD

Do not charge pulsation dampeners with oxygen. Oxygen may cause an explosion causing personal injury, death or property damage.

1. Use nitrogen only when charging pulsation dampeners, **DO NOT USE OXYGEN.**
2. Use proper charging tools to charge pulsation dampeners.
3. Charge pulsation dampener within specifications stated on data sheet to assure proper pulsation dampening and prevent failure of bladder.

H. FALL HAZARD

Do not operate pressure washer while standing on slippery or unstable surface unless extraordinary safety precautions are observed. Pressure washing may create slippery surface on which a person may slip and fall causing personal injury or death.

1. Wear suitable footwear to maintain a good grip on wet surfaces.
2. Do not stand on ladders or scaffolding.
3. Do not over reach or stand on unstable supports.
4. Keep good footing and balance and hold gun with both hands to control kick back.

CAUTION

A. IMPROPER USE OF FITTINGS HAZARD

Do not operate the pump with improperly-connected, sized, worn or loose fittings, pipes or hoses. Operating the pump under these conditions could result in personal injury and property damage.

1. Ensure all fittings, pipes and hoses are properly rated for the maximum pressure rating and flow of the pump.
2. Check all fittings and pipes for cracks or damaged threads.
3. Check all hoses for cuts, wear, leaks, kinks or collapse before each use.
4. Ensure all connections are tight and secure.
5. Use PTFE thread tape or pipe thread sealant (sparingly) to reconnect plumbing. Do not wrap tape beyond the last thread, this will prevent loose tape from becoming lodged in the pump or accessories.
6. Apply proper sealants to assure secure fit or easy disassembly when servicing.

B. FROZEN LIQUID HAZARD

Do not operate the pump with frozen liquid. Operating the pump under this condition could over pressurize and jettison the manifold from the crankcase causing personal injury and property damage.

1. Store pump or pumping system in an environmentally-controlled room protected from freezing temperatures.
2. Follow procedures in *TECH BULLETIN 083* to winterize pump.

C. CLEANING PUMP HAZARD

Do not use solvents that are flammable and toxic to clean or degrease equipment. Use of these solvents could result in personal injury and property damage.

1. Follow safety instructions as found in SDS or on packaging of each liquid.
2. Clean equipment in a well-ventilated area.
3. Disposal of solvents to be in accordance with local, state and federal regulations.

D. OPERATING BEYOND SPECIFICATIONS HAZARD

Do not operate the pump outside the specifications of individual pump data sheet or service manual. Operating the pump under these conditions could result in personal injury and property damage.

1. Do not operate the pump faster than the maximum recommended RPM.
2. Do not operate the pump at pressures higher than the maximum recommended pressure.
3. Do not operate the pump at temperatures higher than the maximum recommended temperatures.
4. Do not use accessories that are not compatible or rated for the pump.

General Safety Information and Symbols

E. LIFTING DEVICE HAZARD CONTINUED

Do not lift pump with unsuitable lifting devices. Use of unsuitable lifting devices may cause pump to fall, resulting in personal injury, damage to pump and/or pump with drive/base plate.

1. Lifting eyes installed on the pump must be used only to lift the pump.
2. Special lifting eyes should be installed on the base for lifting the pumping system (e.g. base, drive and accessories)
3. If slings or chains are used for lifting, they must be safely and securely attached to properly balance the weight of the unit.
4. Inspect slings and chains prior to use and replace worn and damaged slings and chains.

NOTICE

A. OIL HAZARD

Use only genuine Cat Pumps custom-blend, premium-grade, petroleum-based hydraulic oil. Use of other oil may not provide proper lubrication of drive-end components and may result in damage to the crankcase of the pump.

1. Fill pump crankcase to specific capacity indicated on data sheet or service manual prior to startup.
2. Cat Pumps premium custom-blend oil is available worldwide in 21-ounce bottles, (single and 12-pack cases), 2.5 gallon jugs (single and 2-pack) or 30 gallon drums. **Use of other oils may void the warranty.**

B. PUMP ROTATION DIRECTION HAZARD

Do not rotate pump crankshaft in reverse direction. Rotation of pump crankshaft in reverse direction may not provide proper lubrication and may result in damage to the drive-end components.

1. Forward rotation is the top of the crankshaft turning towards the manifold head of the pump.
2. Ensure oil is filled to the center red dot on sight gauge for forward rotation.
3. If reverse rotation is unavoidable, ensure oil is filled to slightly above center red dot on sight gauge.

C. BELT TENSION HAZARD

Do not operate pump with excessive belt tension. Excessive belt tension may damage the pump's bearings or reduce horsepower.

1. Rotate pump crankshaft before starting to ensure shaft and bearings are moving freely.
2. Ensure pulleys are properly sized.
3. Periodically replace belts to assure full horsepower transmission.
4. Ensure center distance dimensions between pulleys is correct.

D. BYPASS OPERATION HAZARD

Do not operate the pump in bypass for extended lengths of time. Operating the pump under this condition can quickly cause heat build-up resulting in damage to the pump.

1. Route bypass line to supply reservoir to dissipate heated bypass liquid into a large reservoir of cool water to reduce excessive temperature build-up.
2. Route bypass line to inlet of pump using a thermo valve in the bypass line or auto shut-off assembly that will sense temperature rise and either bypass or shut down system before damage occurs.

E. DRY OPERATION HAZARD

Do not operate the pump without water or liquid. Operating pump under these conditions could result in damage to the pump.

1. Open all valves on inlet side of pump before starting operation to prevent starving the pump.
2. Do not exceed inlet suction pressure limit specified in pump data sheet.
3. Ensure inlet feed exceeds the maximum flow being delivered by the pump.
4. Ensure all fittings, pipes and hoses are properly-sized for the pump to avoid restricted flow.
5. Review and implement all other recommendations appropriate for your system from the *Inlet Condition Check-List*.

CAUTION: Before commencing with service, shut off drive (electric motor, gas or diesel engine) and turn off water supply to pump. Relieve all discharge line pressure by triggering gun or opening valve in discharge line.

After servicing is completed, turn on water supply to pump, start drive, reset pressure regulating device and secondary valve, read system pressure on the gauge at the pump head. Check for any leaks, vibration or pressure fluctuations and resume operation.

Inspect and service all system accessories on the same schedule as your pump.

Servicing the Seals

MANIFOLD AND SEAL REMOVAL

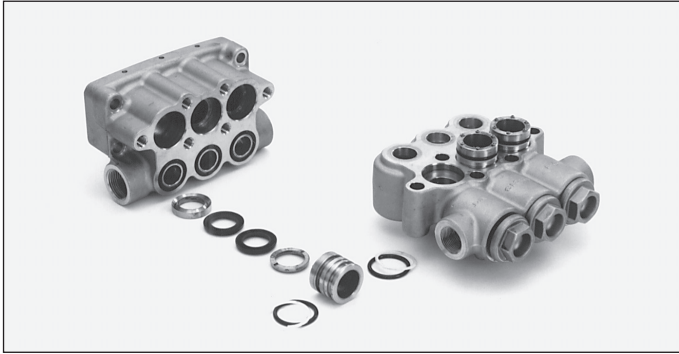

1530, 1531
V-Packing Arrangement

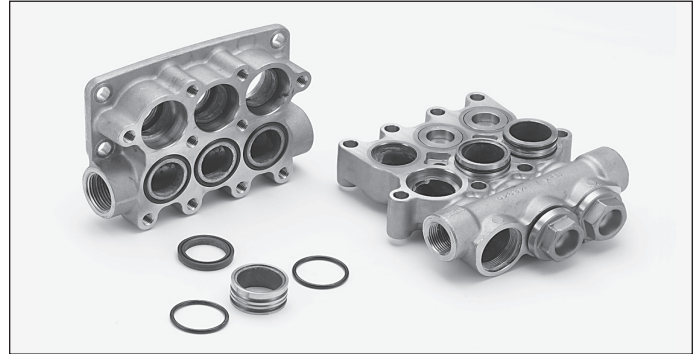

1540, 1540E
High-Pressure Seal Arrangement

REMOVING THE DISCHARGE MANIFOLD

1. Remove the hex head (HSH) screws.
2. Support the manifold from the underside and tap the backside of the discharge manifold with a soft mallet to gradually work manifold from pump.
3. Remove the O-rings from lower chambers of the face of the inlet manifold.

REMOVING THE INLET MANIFOLD

1. Remove the HSH Screws. Use an adjustable wrench to rotate the crankshaft to begin the separation of the inlet manifold from the crankcase.
2. Support the manifold from the underside and tap the rear of the inlet manifold with a soft mallet to gradually remove from pump.

NOTE: Two screwdrivers on opposite sides of the manifold may be used to assist separation.

SERVICING THE SEALS

Disassembly

1. To service the seals and packings, it is necessary to remove both the discharge and inlet manifolds. Follow disassembly procedures for REMOVING THE DISCHARGE MANIFOLD and REMOVING THE INLET MANIFOLD.
NOTE: On models 1530, 1531, 2510, 2511, the spacer with coil springs may stay in the discharge manifold or inlet manifold. On models 1540, 1540E, the high-pressure seal spacer will generally stay in the inlet manifold.
2. Models 1530, 1531, 2510, 2511: Remove the spacer with coil springs from either manifold and exposed O-rings and backup rings from the spacer.
Models 1540, 1540E, 1560, 1580: Remove the exposed O-ring. Insert two (2) screwdrivers into the grooves on opposite sides of the spacer and pry from the chamber.
NOTE: Exercise caution as the screwdrivers may score O-ring sealing surface.

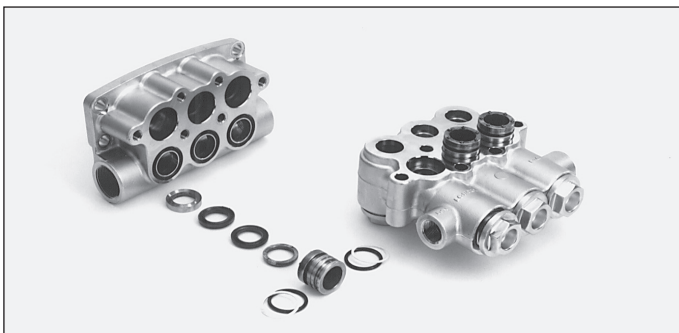

2510, 2511
V-Packing Arrangement

3. Models 1530, 1531, 2510, 2511: Remove male adapter, two (2) V-Packings and female adapter from each seal chamber.
Models 1540, 1540E: Remove high-pressure seal from each seal chamber.
Models 1560, 1580: Remove three (3) V-Packings (1560), two (2) V-Packings (1580) and female adapter from each seal chamber.
4. Place the inlet manifold on the work surface with crankcase side up.
5. Models 1530, 1531, 1540, 1540E, 1560, 1580: Use a screwdriver to remove low-pressure seal from backside of manifold.
Models 2510, 2511: Use a screwdriver to remove washer and low-pressure seal from backside of manifold.

NOTICE: Exercise caution as the screwdriver may score O-ring sealing surface.

Reassembly

NOTE: For certain applications apply liquid gasket to the O-ring crevices and seal surfaces. Refer to **Tech Bulletin 053** for model identification.

NOTE: EPDM elastomers require silicone-based lubricant.

NOTE: For standard applications, apply a small amount of oil to the outside edge of the LPS, HPS, VP, MA, FA and O-rings for ease of installation and to avoid damage.

1. Examine low-pressure seals for wear to the internal ridges, outer surfaces or for broken springs. Replace as needed.
2. Press low-pressure seal into each seal chamber of the Inlet Manifold with the garter spring down.
Models 2510, 2511: Install washers into each seal chamber.
NOTE: When using alternate materials, the fit of the special materials may be snug and require gently driving the low-pressure seal into position with a cylinder of the same diameter to ensure a square seating and no damage to the low-pressure seal.
3. Models 1530, 1531, 2510, 2511: Examine the spacer with coil springs for scale build-up, wear, broken or fatigued coil springs. Replace as needed. Examine both front and rear O-rings and backup rings for cuts or deterioration, replace as needed.
Models 1540, 1540E: Examine the high-pressure seal spacer for scale build-up or wear and replace as needed. Examine the front and rear O-rings for cuts or deterioration and replace as needed.
4. Models 1530, 1531, 2510, 2511: Examine male and female adapters for wear. Replace as needed.
Models 1560 1580: Examine female adapter and spacer. Replace as needed.
5. Models 1530, 1531, 1560, 2510, 2511: Examine V-Packings for frayed edges or uneven wear. Replace as needed.
Models 1540, 1540E: Examine high-pressure seals for frayed edges or uneven wear. Replace as needed.

Servicing the Plungers

DISASSEMBLY AND REASSEMBLY



1530, 1531
Low-Pressure Seal



1540, 1540E
Low-Pressure Seal



2510, 2511
Low-Pressure Seal

Reassembly (Continued)

- Place the inlet manifold on work surface with crankcase side down.
- Models 1530, 1531, 1560, 1580, 2510, 2511: Place the female adapter with flat side down, "V" side up, into each seal chamber.
- Models 1530, 1531, 1580, 2510, 2511: Fit two (2) new V-Packings together. Model 1560: Fit three (3) new V-Packings together.
Lubricate the outer surface of the packings and insert into seal chamber with the "V" side down. The "V" will mate with "V" side of the female adapter.
- Models 1530, 1531, 1560, 1580, 2510, 2511: Place male adapter with "V" side down inside each seal chamber.
- Models 1530, 1531, 2510, 2511: Lubricate outer surface of spacer with coil springs and insert into seal chamber until completely seated.
- Models 1540, 1540E: Lubricate outer surfaces of high-pressure seals and position into seal chamber with metal side down, grooved side up. Lubricate the outer O-rings on the high-pressure seal spacer and press into inlet manifold seal chamber.
- Model 1540E ONLY: Apply liquid gasket ThreeBond 1207D® to the face of the crankcase and inlet manifold to maintain a moisture-free seal. Refer to Tech Bulletin 100.
- Support the inlet manifold from the under side and slide over plungers. Apply Loctite® 242® to HSH screw threads and thread in hand tight. Torque in sequence to specifications in torque chart.
- Install new O-rings at bottom face of inlet manifold.
- Support the discharge manifold from the under side and press discharge manifold into inlet manifold. Thread HSH screws in hand tight. Torque in sequence to specifications in torque chart

NOTE: It is highly recommended that antiseize lubricant (PN 6119) be applied to the threads on all stainless steel components to prevent galling.

Loctite and 242 are registered trademarks of the Henkel Corporation. ThreeBond is a registered trademark of ThreeBond Co., LTD.

SERVICING THE PLUNGERS

Disassembly

- To service the plungers, it is necessary to remove the discharge and inlet manifolds. Follow disassembly procedures for REMOVING THE DISCHARGE MANIFOLD and REMOVING THE INLET MANIFOLD.
- Models 1530, 1531, 1560, 1580: Remove the two-piece seal retainer and wick from each plunger rod.
Models 2510, 2511: Remove the one-piece seal retainer and wick from each plunger rod.
Model 1540, 1540E: Remove the one-piece seal retainer from each plunger rod.
- Using a wrench, loosen the plunger retainers about three to four turns.
- Push the ceramic plungers back towards the crankcase to separate from the plunger retainers and proceed with unthreading the plunger retainers by hand.
- Remove plunger retainers, O-rings, backup rings and gaskets.
NOTE: On Models 1531, 2510, 2511, the plunger retainer studs may stay on plunger rods or come off with plunger retainers.
- Models 1530, 1531, 1540, 1540E: Remove ceramic plungers and barrier slingers.
Models 1560, 1580, 2510, 2511: Remove ceramic plungers, keyhole washers and barrier slingers.

Reassembly

- Visually inspect crankcase oil seals for deterioration or leaks and contact Cat Pumps for assistance with replacement.
- Examine plunger retainers, studs, barrier slingers and keyhole washers for wear and replace as needed.
- Models 1530, 1531, 1540, 1540E: Slide barrier slingers over plunger rods with concave side away from crankcase.
Models 1560, 1580, 2510, 2511: Slide keyhole washer over plunger rods with split ends facing downward.
- Examine ceramic plungers for scoring, scale build-up, chips or cracks and replace as needed. Generally, the ceramic plungers do not need to be replaced.
- Slide ceramic plungers over plunger rods.
NOTE: Ceramic plunger can only be installed in one direction. Do not force onto plunger rod.
NOTE: Do not lubricate wicks at initial start-up. Operate for 10 to 15 minutes to allow grease from low-pressure seal to penetrate the plunger surface, then lubricate as needed.
- Examine gaskets, O-rings and backup rings for cuts or wear and replace as needed.
- Models 1530, 1531, 1560, 1580, 2510, 2511: Install gaskets first, then O-rings and backup rings onto plunger retainers.
NOTE: Lubricate O-rings and backup rings for ease in installation and to reduce possible damage.
Models 1540, 1540E: Install gasket onto plunger retainers.

Servicing the Valves

VALVE REMOVAL

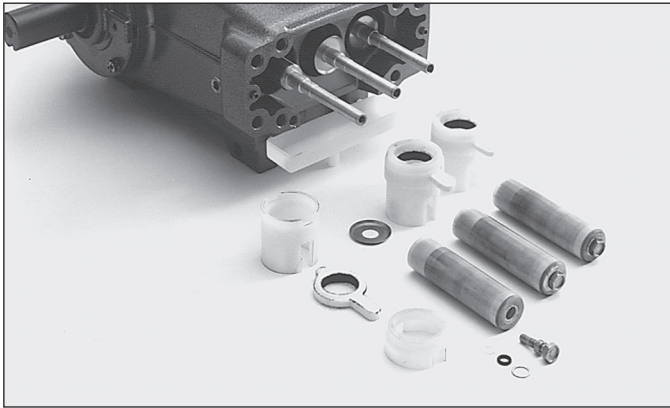

1530, 1541
Plunger Arrangement

Reassembly (Continued)

- Apply Loctite® 242® to exposed threads on the plunger retainer and torque per chart.
- Rotate the crankshaft so the two outside plungers are extended the same distance.
- Models 1530, 1531, 1560, 1580, 2510, 2511: Install seal retainer onto the plunger rod with new wicks, long tab down.
Models 1530, 1531, 1560, 1580: The drain slots should face the crankcase with openings to the top and bottom.
Models 1540, 1540E, 2510, 2511: The seal retainer openings should be at top and bottom. Press completely into crankcase.
- Lightly lubricate ceramic plungers to assist in installing into the manifold.
- Support the inlet manifold from the under side and slide over plungers. Press completely into crankcase. Apply Loctite® 242® to HSH screw threads and thread in hand tight. Torque in sequence to specifications in torque chart.
- Install new O-rings at bottom inlet ports of inlet manifold.
- Support the discharge manifold from the under side and align with inlet manifold. Thread in hand tight. Torque in sequence to specifications in torque chart.

NOTE: It is highly recommended that antiseize lubricant (PN 6119) be applied to the threads on all stainless steel components to prevent galling.

Loctite and 242 are registered trademarks of the Henkel Corporation.



1530, 1541
Plunger Arrangement

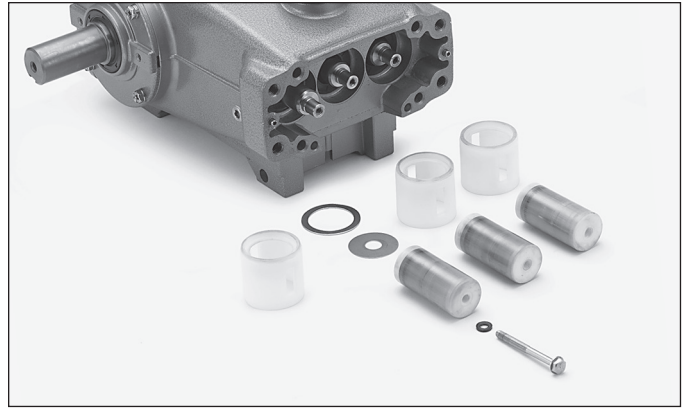

1540, 1540E
Plunger Arrangement

SERVICING THE VALVES

Disassembly

- Models 1530 1531, 1540, 1540E, 2510, 2511: Remove the hex valve plugs with O-ring.
Models 1560, 1580: Remove the eight (8) hex socket head (HSH) screws and valve cover. Remove valve plugs with O-ring and backup ring.
- Models 1530 1531, 2510, 2511: Remove the exposed coil spring and washer from the top of the spring retainer.
Models 1540 and 1540E: Remove washer from the top of the spring retainer.
- Models 1530, 1531, 1540, 1540E, 2510 and 2511: Use a pliers to grasp the spring retainer by the tab at the top and remove from valve chamber. Normally the valve assembly will remain together. If the assembly separates during removal, use a reverse pliers and lift the seat from the chamber.
Models 1560, 1580: Use a reverse pliers to grasp the spring retainer and remove the stacked valve assemblies.
- To separate valve assemblies, insert screwdriver into spring retainer and use a twisting motion on the backside of valve until seat separates from the spring retainer. Each assembly consists of a spring retainer, spring, valve, seat, O-ring and backup ring.
Models 1540, 1540E ONLY: The discharge manifold must be removed in order to remove the inlet valve assemblies. Follow disassembly procedure for REMOVING THE DISCHARGE MANIFOLD.

Reassembly

NOTE: For certain applications apply liquid gasket to the O-ring crevices and seal surfaces. Refer to **Tech Bulletin 053** for model identification.

NOTE: EPDM elastomers require silicone-based lubricant.

- Examine spring retainers for internal wear or breaks in the structure and replace as needed.
- Examine springs and coil springs for fatigue or breaks and replace as needed.
- Examine valves and seats for grooves, pitting or wear and replace as needed.
- Examine seat O-rings and backup rings for cuts or wear and replace as needed.
- Models 1530, 1531, 2510, 2511: Install O-ring, then backup ring onto seat.
Models 1540, 1540E: Install O-ring onto seat.
- Place the valve onto the seat with dish side down.
- Place spring on valve and snap the spring retainer onto seat.
- Models 1560, 1580: Install O-ring onto small diameter inlet seat.
- Place the valve onto the seat with dish side down.

Servicing the Crankcase

SERVICING THE CRANKCASE



1530, 1531
Complete Inlet/Discharge Valve Assembly



1540, 1540E
Complete Inlet/Discharge Valve Assembly

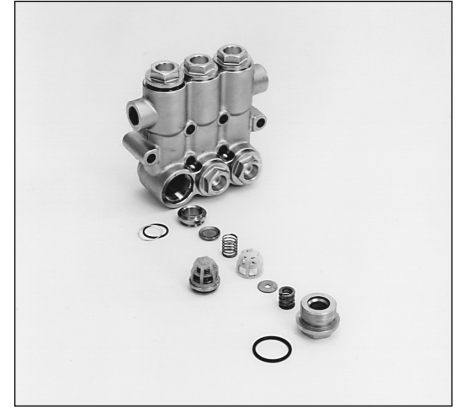

2510, 2511
Complete Inlet/Discharge Valve Assembly

Reassembly (Continued)

- Place spring on valve and snap longer spring retainer with large opening onto seat.
- Install O-ring, then backup ring onto discharge seat. Snap discharge seat onto inlet spring retainer.
- Place valve onto seat with dish side down.
- Place spring on valve and snap smaller spring retainer onto discharge seat.
- Lubricate outer O-ring and backup ring surface and walls of valve chamber. Press valve assembly squarely into valve chamber until completely seated.
- Models 1530, 1531, 2510, 2511: Place washer, then coil spring on top of the spring retainer.
Models 1540, 1540E: Place washer on top of the spring retainer.
- Models 1540, 1540E (inlet valve assemblies): Place washer into valve chamber on back side of manifold. Lubricate outer O-ring and press valve assembly into valve chamber, retainer first, until completely seated.
- Examine the O-ring on the valve plug and replace if cut or worn. Lubricate new O-ring before installing on valve plug to avoid damaging as they are worked over the plug threads.
NOTE: It is highly recommended that antiseize lubricant (PN 6119) be applied to the threads on all stainless steel components to prevent galling.
- Models 1530, 1531, 1540E, 2510, 2511: Slowly thread the valve plug into chamber. Exercise caution to avoid extruding or cutting the O-ring. Torque to specifications in torque chart.
- Models 1560, 1580: Place valve cover over valve plugs. Thread HSH screws in hand tight. Torque to specifications in torque chart.
- Install new O-rings at bottom inlet ports of inlet manifold. Support the discharge manifold from the under side and press discharge manifold into inlet manifold. Thread HSH screws in hand tight. Torque in sequence to specifications in torque chart.

SERVICING THE CRANKCASE SECTION

- While manifolds, plungers and seal retainers are removed examine crankcase oil seals for leaking and wear.
- Check for any signs of leaking at rear cover, drain plug, bubble gauge and dipstick (2510, 2511).
Model 1540E ONLY: When servicing the crankshaft seal, bearing cover or rear cover, apply liquid gasket ThreeBond 1207D to the face of the crankcase, inlet manifold, bearing covers and rear cover O-ring groove to maintain a moisture-free seal. Refer to **Tech Bulletin 100**.
- Check oil level and check for evidence of water in oil. Change crankcase oil on a regular schedule. See Preventative Maintenance Check-List.
- Rotate crankshaft by hand to feel for smooth bearing movement.
- Examine crankshaft oil seals externally for drying, cracking or leaking.
- Contact Cat Pumps or your local distributor if crankcase service is required. Refer to **Tech Bulletin 035**.

Reference Information

TORQUE CHART

PUMP ITEM		THREAD	TOOL SIZE	TOOL PART NUMBER	TORQUE		
					IN-LBS	FT-LBS	Nm
Plunger Retainers	15PFR	M6	12mm Combination Wrench	—	55	4.6	6.2
	25PFR	M7	14mm Combination Wrench	—	108	9.0	12.2
Inlet Manifold Screws	15PFR	M10	8mm Hex Bit Socket with Ratchet	—	222	18.5	25.0
	25PFR	M12	10mm Hex Bit Socket with Ratchet	—	355	30.0	40.0
Discharge Manifold Screws	1540, 1540E	M10	8mm Hex Bit Socket with Ratchet	—	250	21.0	28
	1530, 1531, 1560	M12	10mm Hex Bit Socket with Ratchet	—	355	30.0	40.0
	1580, 2510, 2511						
Valve Plugs	15PFR	M36	32mm Socket with Ratchet	—	1060	88	119
	25PFR	M42	36mm Socket with Ratchet	—	1680	140	190
Valve Plug Cover Screws	1560, 1580	M12	10mm Hex Bit Socket with Ratchet	—	250	21.0	28
Rear Cover Screws and Bearing Cover Screws	15PFR	M6	10mm Combination Wrench	—	50	4.0	5.4
	25PFR	M8	13mm Combination Wrench	—	115	9.58	13
Connecting Rod Screws	15PFR, 25PFR	M8	13mm Combination Wrench	—	216	18	24
Bubble Oil Gauge	15PFR Only	M28	Oil Gauge Tool	44050	45	3.8	5.0

TECHNICAL BULLETIN REFERENCE CHART

NO.	SUBJECT	MODELS
002	Inlet Pressure vs. Liquid Temperature	All Models
003	Power Unit Drive Packages	3PFR–68PFR, 10PFR–60PFR
024	Lubrication of Low-Pressure Seals	All Models
035	Servicing Crankcase Section	7CP, 7PFR–68PFR
036	Cylinder and Plunger Reference Chart	All Models
043	Servicing the Low and High- Pressure Seals	All Plunger Models
053	Liquid Gasket	All Plunger NAB Stainless Steel Models
064	Bypass Hose Sizing	All Unloaders/Regulators
074	Torque Chart	Piston and Plunger Pumps
083	Winterizing a Pump	All Models
085	M8 Keyway	25FR, 25PFR, 28PFR
095	Galling Preventative	All Stainless Steel Models
100	Crankcase and Model Number Change	1540 to 1540E

TORQUE SEQUENCES

Models: 1530, 1531, 1560, 1580, 2510, 2511

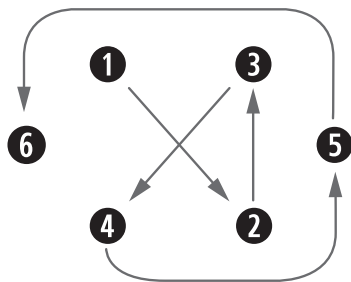

Models: 1540, 1540E

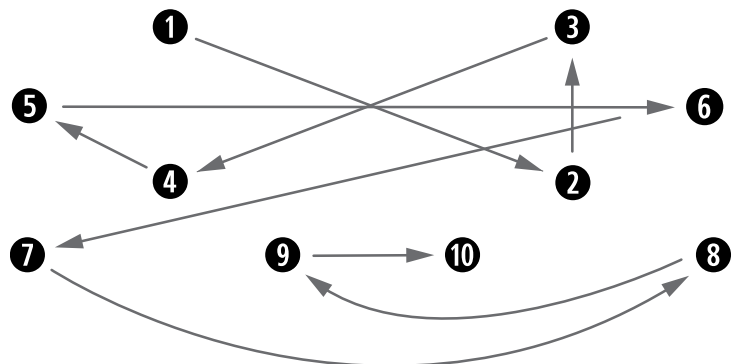

Reference Information

PREVENTIVE MAINTENANCE SCHEDULE

Many application factors determine proper pump maintenance intervals. Variation in duty cycle, operating performance, fluid temperature, fluid type, inlet conditions and application environment can affect maintenance schedules. Every application should be evaluated and serviced based on its own requirements. The following checklist is intended as a reference guide only.

CHECK	DAILY	WEEKLY	50 HRS.	500 HRS.	1500 HRS.	3000 HRS.
Filters	• or •					
Oil Level/Quality	• or •		①	①		
Water Leaks	• or •					
Oil Leaks	•					
Plumbing		•				
Belts, Pulley		•				
Accessories					•	
Seals					②	
Valves						③

Water leaks or loss of system performance can be an indicator of seal wear. Seal wear has many causes, including contaminated liquid or high-temperature/run dry operation. If the low-pressure seals show wear, the high-pressure seals most likely are in a similar condition. It is a good practice to replace both low and high-pressure seals and inspect plungers when leaks are present.

- ① Cat Pumps recommends using our custom-blend premium grade hydraulic oil formulated to meet Cat Pumps specifications. For best results, perform an initial oil change after the first 50 hours of operation and every 500 hours thereafter.
- ② Every system operates under different conditions. Past performance and maintenance history are the best indicators of future performance. If system performance degrades or changes, check seals and valves immediately. Service as required to restore system performance. Depending upon operating conditions, maintenance intervals for seals kits range between 1,500 and 8,000 hours.
- ③ Pump valves typically require changing every other seal change. If system performance degrades or changes, check valves immediately. Depending upon operating conditions, maintenance intervals for valve kits range between 3,000 and 16,000 hours.

Cat Pumps custom blend crankcase oil is exclusively designed, tested and proven to maximize the life of your pump. This special formulated premium-grade, petroleum-based, ISO 68 hydraulic oil contains the most advanced additive package to protect against wear, oxidation, rust and corrosion.

Cat Pumps premium custom-blend oil is available worldwide in 21-ounce bottles, (single and 12-pack cases), 2.5 gallon jugs (single and 2-pack) or 30 gallon drums. **Use of other oils may void the warranty.**



Diagnosis and Maintenance

This service manual is designed to assist you with the disassembly and reassembly of your pump. The following guide will assist in determining the cause and remedy to various operating conditions. You can also review our **FAQ** or **SERVICE & TRAINING** sections on our **WEB SITE** for more facts or contact Cat Pumps directly.

PROBLEM	PROBABLE CAUSE	SOLUTION
Low pressure	<ul style="list-style-type: none"> • Worn nozzle. • Air leak in inlet plumbing. • Pressure gauge inoperative or not registering accurately. • Relief valve stuck, partially plugged or improperly adjusted. • Inlet suction strainer (filter) clogged or improperly sized. • Abrasives in pumped liquid. • Leaky discharge hose. • Inadequate liquid supply. • Severe cavitation. • Worn seals. • Worn or dirty inlet/discharge valves. 	<ul style="list-style-type: none"> • Replace with proper size nozzle. • Tighten fittings and hoses. Use PTFE liquid or tape. • Check with new gauge. Replace worn or damaged gauge. • Clean/adjust relief valve. Replace worn seats/valves and O-rings. • Clean filter. Use adequate size filter. Check more frequently. • Install proper filter. • Replace discharge hose with proper rating for system. • Pressurize inlet. • Check inlet conditions. • Install new seal kit. Increase frequency of service. • Clean inlet/discharge valves or install new valve kit.
Pulsation	<ul style="list-style-type: none"> • Foreign material trapped in inlet/discharge valves. 	<ul style="list-style-type: none"> • Clean inlet/discharge valves or install new valve kit.
Water leak		
<ul style="list-style-type: none"> • Under the manifold • Into the crankcase 	<ul style="list-style-type: none"> • Worn high-pressure or low-pressure seals. • Humid air condensing into water inside the crankcase. • Excessive wear to high-pressure or low-pressure seals. 	<ul style="list-style-type: none"> • Install new seal kit. Increase frequency of service. • Install new oil cap protector. Change oil every 3 months or 500 hours. • Install new seal kit. Increase frequency of service.
Knocking noise		
<ul style="list-style-type: none"> • Inlet supply • Bearing 	<ul style="list-style-type: none"> • Inadequate inlet liquid supply. • Broken or worn bearing. 	<ul style="list-style-type: none"> • Check liquid supply. Increase line size or pressurize. • Replace bearing.
Oil leak		
<ul style="list-style-type: none"> • Crankcase oil seal • Crankshaft oil seal and O-ring • Drain plug • Bubble gauge • Bearing cover • Filler cap 	<ul style="list-style-type: none"> • Worn crankcase oil seal. • Worn crankshaft oil seal or O-ring on bearing cover. • Loose drain plug or worn drain plug O-ring. • Loose bubble gauge or worn bubble gauge gasket. • Loose bearing cover or worn bearing cover O-ring. • Loose filler cap or excessive oil in crankcase. 	<ul style="list-style-type: none"> • Replace crankcase oil seal. • Remove bearing cover and replace O-ring and/or oil seal. • Tighten drain plug or replace O-ring. • Tighten bubble gauge or replace gasket. • Tighten bearing cover or replace O-ring. • Tighten filler cap. Fill crankcase to specified capacity.
Pump runs extremely rough		
<ul style="list-style-type: none"> • Inlet conditions • Pump valves • Pump seals 	<ul style="list-style-type: none"> • Restricted inlet or air entering the inlet plumbing. • Stuck inlet/discharge valves. • Leaking high-pressure or low-pressure seals. 	<ul style="list-style-type: none"> • Correct inlet size plumbing. Check for air tight seal. • Clean out foreign material or install new valve kit. • Install new seal kit. Increase frequency of service.
Premature seal failure		
	<ul style="list-style-type: none"> • Scored plunger. • Over pressure to inlet manifold. • Abrasive material in the liquid being pumped. • Excessive pressure and/or temperature of pumped liquid. • Running pump dry. • Starving pump of adequate liquid. • Eroded manifold. 	<ul style="list-style-type: none"> • Replace plunger. • Reduce inlet pressure per specifications. • Install proper filtration at pump inlet and clean regularly. • Check pressure and inlet liquid temperature. • DO NOT RUN PUMP WITHOUT LIQUID. Fill pump with oil. • Increase hose one size larger than inlet port size or pressurize. • Replace manifold. Check liquid compatibility.

⚠ CAUTIONS AND WARNINGS

All high-pressure systems require a primary pressure regulating device (i.e. regulator, unloader) and a secondary pressure relief device (i.e. pop-off valve, relief valve). Failure to install such relief devices could result in personal injury or damage to pump or property. Cat Pumps does not assume any liability or responsibility for the operation of a customer's high-pressure system. Read all CAUTIONS and WARNINGS before commencing service or operation of any high-pressure system. The CAUTIONS and WARNINGS are included in each Service Manual and with each Accessory Data sheet. CAUTIONS and WARNINGS can also be viewed online at www.catpumps.com/dynamic-literature/cautions-and-warnings or can be requested directly from Cat Pumps.

WARRANTY

View the Limited Warranty on-line at www.catpumps.com/literature/cat-pumps-limited-warranty



PIJTTERSEN

Pijtersen B.V.
Beneluxweg 33
9636 HV Zuidbroek
Tel.: +31(0)50-8200963

KvK 01013855
BIC RABONL2U
BTW NL002166811B01
IBAN NL24 RABO 0353 2970 97

www.pijtersen.nl - info@pijtersen.nl | www.catpumps.nl - info@catpumps.nl

