

DATA SHEET

5CP PLUNGER PUMPS



Stainless Steel

Models:

5CP6221, 5CP6241CS, ' 5B(\$ #

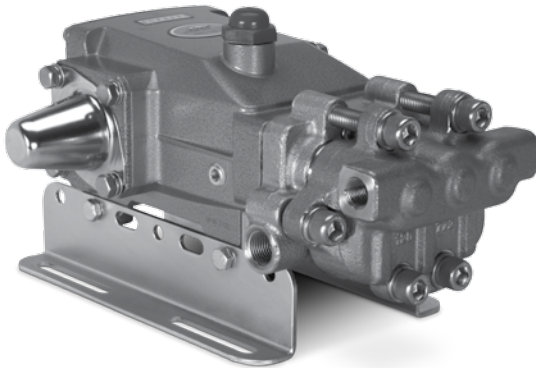

Model 5CP6221 Shown
(Rails and shaft protector sold separately)

FEATURES

- 316 Stainless Steel wet end
- Various Drive configurations including direct drive bell housing to electric motor, belt drive to engine or motor, and direct drive to hydraulic motor
- Standard NBR seals with alternative options for temperature and chemical compatibility
 - FPM – .0110
 - EPDM – .0220

COMMON SPECIFICATIONS

	U.S.	Metric
Bore	0.787"	20 mm
Crankcase Capacity	17 oz.	0.53 l
Max. Liquid Temperature	160°F	71°C
Above 130°F call Cat Pumps for inlet conditions and elastomer recommendations.		
Inlet Ports (2)	1/2" NPT(F)	1/2" NPT(F)
Discharge Ports (2)	3/8" NPT(F)	3/8" NPT(F)
Shaft Diameter	0.787"	20 mm
Weight	20 lbs.	8 kg
Dimensions	11.47 x 10.0 x 5.75"	291.3 x 254 x 146

SPECIFICATIONS

	U.S. Measure	Metric Measure
5CP6221 Belt Drive		
Flow	6.0 gpm	23 lpm
Pressure Range	100-2000 psi	7-138 bar
Inlet Pressure Range	-5 to 60 psi	-0.35 to 4 bar
RPM	1400 rpm	1400 rpm
Stroke	0.709"	18 mm

5CP6221 ALTERNATE SPECIFICATIONS

Flow	7.4 gpm	28 lpm
Pressure Range	100 to 1200 psi	7 to 83 bar
Inlet Pressure Range	Flooded to 60 psi	Flooded to 4 bar
RPM	1725rpm	1725 rpm
Stroke	0.709"	18 mm

5CP6241CS Direct Drive

Flow	4.0 gpm	15 lpm
Pressure Range	100-2000 psi	7-138 bar
Inlet Pressure Range	Flooded to 60 psi	Flooded to 4 bar
RPM	1725 rpm	1725 rpm
Stroke	0.394"	10 mm

5CP6251 Direct Drive

Flow	5.0 gpm	19 lpm
Pressure Range	100-2000 psi	7-138 bar
Inlet Pressure Range	Flooded to 60 psi	Flooded to 4 bar
RPM	1725 rpm	1725 rpm
Stroke	0.472"	12 mm

ELECTRIC HORSEPOWER REQUIREMENTS

MODELS	FLOW		PRESSURE			RPM
			psi 1200	psi 1600	psi 2000	
	U.S. gpm	lpm	bar 83	bar 110	bar 138	
5CP6221	6.0	23	5.0	6.6	8.2	1400
	5.0	19	4.1	5.5	6.8	1208
5CP6221ALT	7.4	28	6.1	NA	NA	1725
5CP6241CS	4.0	15	3.3	4.4	5.5	1725
5CP6251	5.0	19	4.1	5.5	6.8	1725

DETERMINING THE PUMP R.P.M.

$$\frac{\text{Rated gpm}}{\text{Rated rpm}} = \frac{\text{"Desired" gpm}}{\text{"Desired" rpm}}$$

DETERMINING THE REQUIRED H.P.

$$\frac{\text{gpm} \times \text{psi}}{1460} = \frac{\text{Electric Brake}}{\text{H.P. Required}}$$

DETERMINING MOTOR PULLEY SIZE

$$\frac{\text{Motor Pulley O.D.}}{\text{Pump rpm}} = \frac{\text{Pump Pulley O.D.}}{\text{Motor rpm}}$$

See complete Drive Packages [Incls: Pulleys, Belts, Hubs, Key] Tech Bulletin 003.
Refer to pump **Service Manual** for repair procedure and additional technical information.

PARTS LIST

ITEM	PART NUMBER				DESCRIPTION	QTY		
	5CP6221	MATL	5CP6241CS	MATL				
2	30057	STL	30057	STL	30057	STL	Key (M6x6x25)	1
5	119049	SS	119049	SS	119049	SS	Screw, HHC, Sems (M8x16)	8
8	46910	AL	46910	AL	46910	AL	Cover, Bearing	2/1
10	14028	NBR	14028	NBR	14028	NBR	O-Ring, Cover, Bearing - 70D	2/1
11	43222	NBR	43222	NBR	43222	NBR	Seal, Oil, Crankshaft - 70D	2
15	14480	STL	14480	STL	14480	STL	Bearing, Ball	2
20	48742	TNM	48742	TNM	48742	TNM	Rod Assy, Connecting [10/01]	3
25	46928	FCM	—	—	46982	FCM	Crankshaft, Dual End	1
	—	—	48203	FCM	—	—	Crankshaft, Single End	1
30	—	—	48224	AL	—	—	Cover, Blind Bearing	1
31	127409	—	127409	—	127409	—	Cap, Vented w/ O-Ring (Rain Cap)	1
32	46798	—	46798	—	46798	—	Cap, Oil Filler	1
33	14179	NBR	14179	NBR	14179	NBR	O-Ring, Oil Filler Cap - 70D	1
37	92241	—	92241	—	92241	—	Gauge, Oil, Bubble w/Gasket - 80D	1
38	44428	NBR	44428	NBR	44428	NBR	Gasket, Flat, Oil Gauge - 80D	1
40	92538	S	92538	S	92538	S	Screw, HHC, Sems (M6x16)	4
48	25625	STCP	25625	STCP	25625	STCP	Plug, Drain (1/4X19BSP)	1
49	23170	NBR	23170	NBR	23170	NBR	O-Ring, Drain Plug - 70D	1
50	46940	AL	46940	AL	46940	AL	Cover, Rear	1
51	14044	NBR	14044	NBR	14044	NBR	O-Ring, Cover, Rear	1
53	48617	AL	48617	AL	48617	AL	Crankcase	1
64	46746	CM	46746	CM	46746	CM	Pin, Crosshead	3
65	48458	BBNP	48458	BBNP	48458	BBNP	Rod, Plunger	3
70	46838	NBR	46838	NBR	46838	NBR	Seal, Oil, Crankcase - 70D	3
71	48208	PVDF	48208	PVDF	48208	PVDF	Washer, Oil Seal	3
75	43328	S	43328	S	43328	S	Slinger, Barrier	3
88	45697	S	45697	S	45697	S	Washer, Keyhole (M18x10)	3
90	46841	CC	46841	CC	46841	CC	Plunger (M20x50)	3
98	46730	NBR	46730	NBR	46730	NBR	Washer, Seal - 90D	3
	48394	FPM	48394	FPM	48394	FPM	Washer, Seal - 90D	3
	◆ 48432	EPDM	◆ 48432	EPDM	◆ 48432	EPDM	Washer, Seal	3
99	† 48201	SS	† 48201	SS	† 48201	SS	Retainer, Plunger (M6x30)	3
100	46749	PVDF	46749	PVDF	46749	PVDF	Retainer, Seal	3
106	44127	NBR	44127	NBR	44127	NBR	Seal, LPS w/SS-Spg	3
	45153	FPM	45153	FPM	45153	FPM	Seal, LPS w/SS-Spg	3
	◆ 48429	EPDM	◆ 48429	EPDM	◆ 48429	EPDM	Seal, LPS w/SS-Spg, 2-Pc w/S Support	3
110	48552	SS	48552	SS	48552	SS	Manifold, Inlet	1
117	119034	S	119034	S	119034	S	Screw, HSH (M8x35)	4
125	44649	SNG	44649	SNG	44649	SNG	Seal, HPS w/SS	3
	44936	FPM	44936	FPM	44936	FPM	Seal, HPS w/SS	3
	46667	HT	46667	HT	46667	HT	Seal, HPS w/S	3
143	17615	NBR	17615	NBR	17615	NBR	O-Ring, I.V. Adapter, Rear - 75D	3
	15855	FPM	15855	FPM	15855	FPM	O-Ring, I.V. Adapter, Rear - 70D	3
	◆ 48431	EPDM	◆ 48431	EPDM	◆ 48431	EPDM	O-Ring, I.V. Adapter, Rear - 75D	3
150	48212	SS	48212	SS	48212	SS	Adapter, Inlet	3
154	43781	NBR	43781	NBR	43781	NBR	O-Ring, I.V. Adapter, Front - 75D	3
	11337	FPM	11337	FPM	11337	FPM	O-Ring, I.V. Adapter, Front - 75D	3
	◆ 48430	EPDM	◆ 48430	EPDM	◆ 48430	EPDM	O-Ring, I.V. Adapter, Front - 75D	3
155	43781	NBR	43781	NBR	43781	NBR	O-Ring, D.V. Adater, Rear - 75D	3
	11337	FPM	11337	FPM	11337	FPM	O-Ring, D.V. Adapter, Rear - 75D	3
	◆ 48430	EPDM	◆ 48430	EPDM	◆ 48430	EPDM	O-Ring, D.V. Adapter, Rear - 75D	3
157	48211	SS	48211	SS	48211	SS	Adapter, Discharge	3
159	43781	NBR	43781	NBR	43781	NBR	O-Ring, D.V. Adapter, Front - 75D	3
	11337	FPM	11337	FPM	11337	FPM	O-Ring, D.V. Adapter, Front - 75D	3
	◆ 48430	EPDM	◆ 48430	EPDM	◆ 48430	EPDM	O-Ring, D.V. Adapter, Front - 75D	3
163	43781	NBR	43781	NBR	43781	NBR	O-Ring, Seat - 75D	3
	11337	FPM	11337	FPM	11337	FPM	O-Ring, Seat - 75D	3
	◆ 48430	EPDM	◆ 48430	EPDM	◆ 48430	EPDM	O-Ring, Seat - 75D	3
164	48216	SS	48216	SS	48216	SS	Seat	6
165	43793	NBR	43793	NBR	43793	NBR	O-Ring, Seat - 90D	6
	43791	FPM	43791	FPM	43791	FPM	O-Ring, Seat - 90D	6
	◆ 48490	EPDM	◆ 48490	EPDM	◆ 48490	EPDM	O-Ring, Seat - 90D	6
166	44038	SS	44038	SS	44038	SS	Valve	6
167	44039	SS	44039	SS	44039	SS	Spring	6
168	44564	PVDF	44564	PVDF	44564	PVDF	Retainer, Spring	6
185	48554	SS	48554	SS	48554	SS	Manifold, Discharge	1
186	19085	S	19085	S	19085	S	Lockwasher, Split (M12)	6
188	120774	S	120774	S	120774	S	Screw, HSH (M12x40)	2
189	89575	S	89575	S	89575	S	Screw, HSH (M12x60)	4
250	118672	STCP	—	—	118672	STCP	Protector, Shaft	1
260	30611	STZP	—	—	—	—	Mount, Rail Assy (Model 5CP6221 Only - Belt)	1
283	34334	—	34334	—	34334	—	Kit, Oil Drain	1
299	816720	SS	816720	SS	816720	SS	Head, Complete	1
300	34353	NBR	34353	NBR	34353	NBR	Kit, Seal (Incls: 98,106,125,143,154,155,159) STD	1
	34351	FPM	34351	FPM	34351	FPM	Kit, Seal (Incls: 98,106,125,143,154,155,159) .0110	1
	◆ 34352	EPDM	◆ 34352	EPDM	◆ 34352	EPDM	Kit, Seal (Incls: 98,106,125,143,154,155,159) .0220	1

EXPLODED VIEW

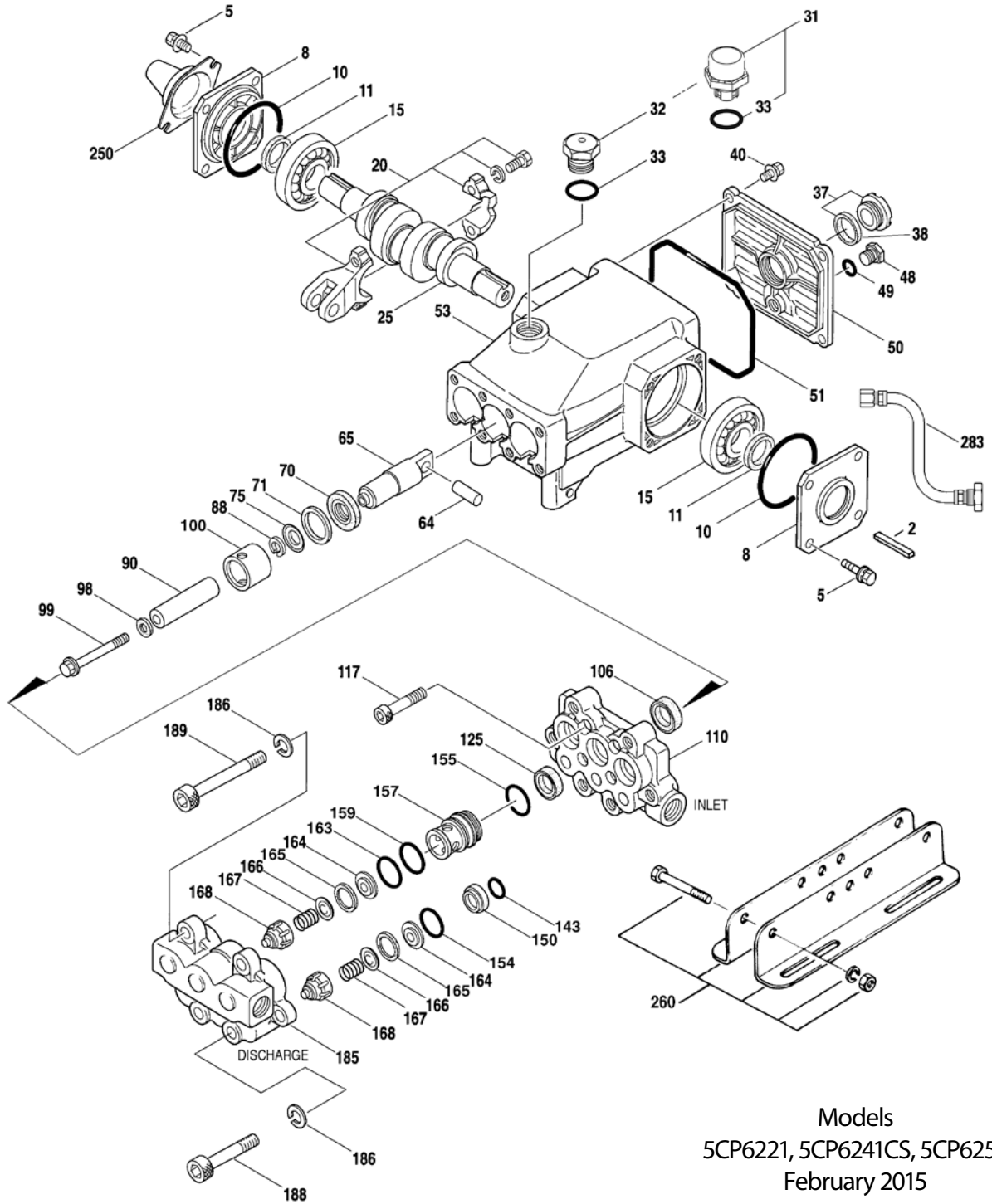

Models
5CP6221, 5CP6241CS, 5CP6251
February 2015

ITEM	5CP6221		PART NUMBER		5CP6251		DESCRIPTION	QTY
	MATL	5CP6241CS	MATL	5CP6251	MATL			
310	33972	NBR	33972	NBR	33972	NBR	Kit, Valve (Incls: 143,154,163,164,165,166,167,168) STD	1
	34362	FPM	34362	FPM	34362	FPM	Kit, Valve (Incls: 143,154,163,164,165,166,167,168) .0110	1
◆	34363	EPDM	◆ 34363	EPDM	◆ 34363	EPDM	Kit, Valve (Incls: 143,154,163,164,165,166,167,168) .0220	1
—	6107	—	6107	—	6107	—	Oil, Bottle (21 oz.) ISO 68 Hydraulic (Fill to specified crankcase capacity prior to start-up)	1
—	6119	—	6119	—	6119	—	Lubricant, Antiseize (2.0 oz.)	1

Bold print part numbers are unique to a particular pump model. *Italics are optional items.* [] Date of latest production change.

◆ Silicone oil/grease required. † Production parts are different than repair parts.

See Tech Bulletins 002, 003, 024, 036, 043, 053, 056, 074, 083, 088 and 095 for additional information.

MATERIAL CODES (Not Part of Part Number): AL=Aluminum BBNP=Brass/Nickel Plated CC=Ceramic CM=Chrome-moly EPDM=Ethylene Propylene Diene Monomer
FCM=Forged Chrome-Moly FPM=Fluorocarbon HT=Hi-Temp (EPDM Alternative) NBR=Medium Nitrile (Buna-N) PVDF=Polyvinylidene Fluoride S=304SS SS=316SS
SNG=Special Blend (Buna) STCP=Steel/Chrome Plated STZP=Steel/Zinc Plated STL=Steel TNM=Special High Strength

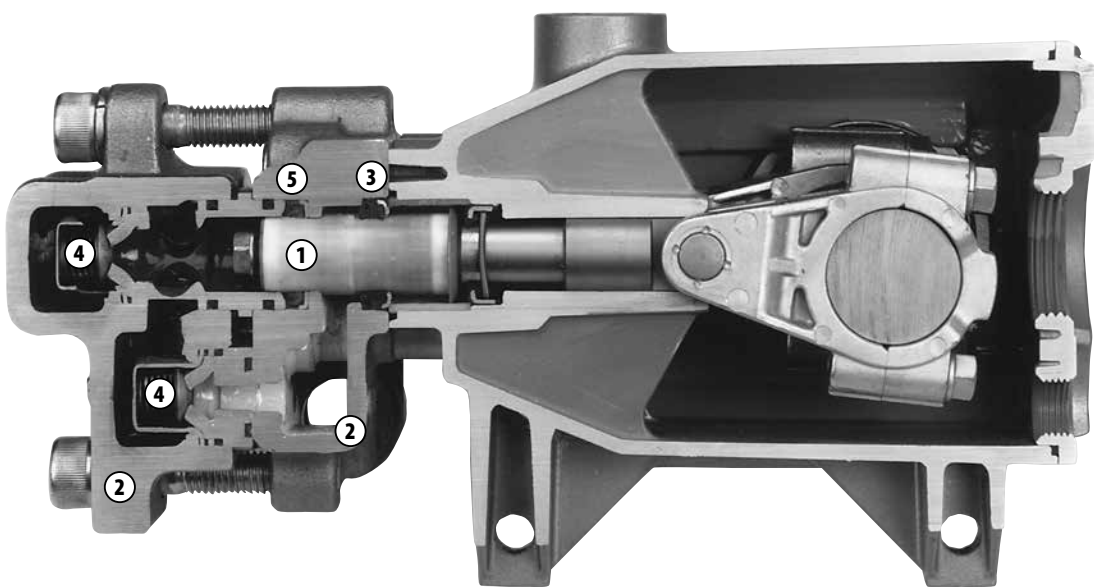
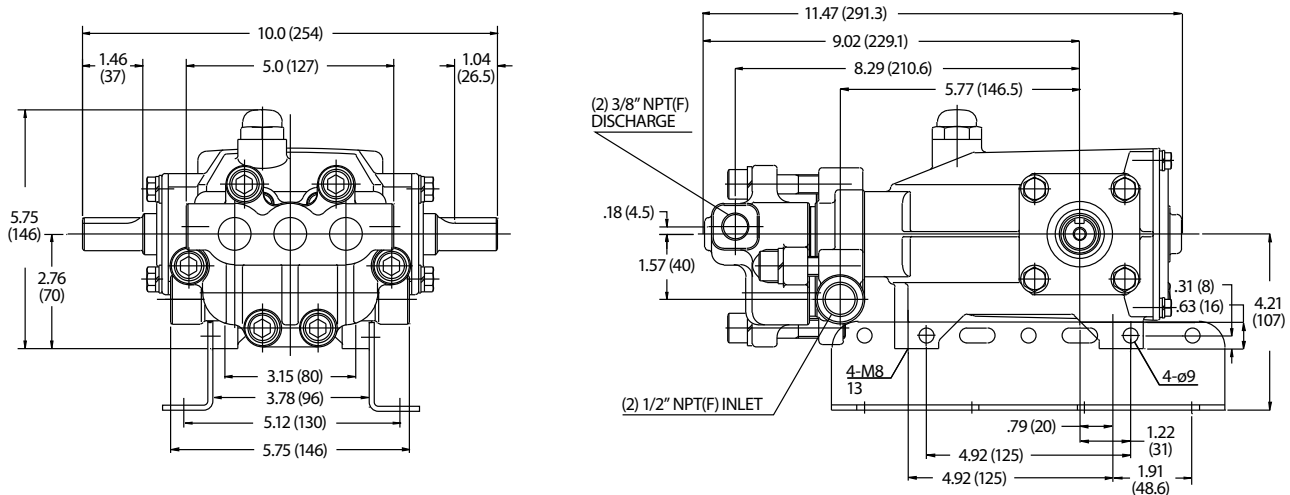

1. Special concentric, high-density, polished, solid ceramic plungers provide a true wear surface and extended seal life.
2. Manifolds are high tensile strength 316 stainless steel for liquid compatibility and long term, continuous duty.
3. 100% wet seal design adds to service life by allowing pumped liquids to cool and lubricate on both sides.
4. 316 stainless steel valves, seats and springs provide corrosion-resistance, ultimate seating and extended life.
5. Specially formulated, Cat Pump exclusive, Hi-Pressure Seals offer unmatched performance and seal life.

⚠ CAUTIONS AND WARNINGS

All High Pressure Systems require a primary pressure regulating device (i.e. regulator, unloader) and a secondary pressure relief device (i.e. pop-off valve, relief valve). Failure to install such relief devices could result in personal injury or damage to pump or property. Cat Pumps does not assume any liability or responsibility for the operation of a customer's high pressure system.

Read all CAUTIONS and WARNINGS before commencing service or operation of any high pressure system. The CAUTIONS and WARNINGS are included in each service manual and with each Accessory Data sheet. CAUTIONS and WARNINGS can also be viewed online at www.catpumps.com/cautions-warnings or can be requested directly from Cat Pumps.

WARRANTY

View the Limited Warranty on-line at www.catpumps.com/warranty.



PIJTTERSEN

Pijtersen B.V.
Beneluxweg 33
9636 HV Zuidbroek
Tel.: +31(0)50-8200963

KvK 01013855
BIC RABONL2U
BTW NL002166811B01
IBAN NL24 RABO 0353 2970 97

