



**PIJTTERSEN**

E-mail : info@pijtersen.nl / info@catpumps.nl  
 Internet: www.pijtersen.nl / www.catpumps.nl

Ultimo aggiornamento: 18/05/2016

# VS 80/400 SST 303 ATEX

Technical manual: E 221

## Safety relief valve



- **60.0550.00**                      1/2" Bsp F
  - **60.0550.50**                      1/2" NPT F
- Body and internal parts made of stainless steel Aisi303.

### CERTIFICATIONS AND STANDARDS

- **Atex Directive 2014/34/EU (DNV 0575 CERTIFICATION)**
- **CE compliant**

### TECHNICAL SPECIFICATIONS

Rated temperature		70°C – 158°F									
Nominal Diameter		DN15									
PN	RATED PRESSURE		PERMISSIBLE PRESSURE		PRE-SET PRESSURE		MAXIMUM FLOW		WEIGHT	INLET OUTLET BYPASS	
	bar	psi	bar	psi	bar	psi	l/min	USGpm	g		
60.0550.00	400	5800	450	6500	-	-	80	21	1180	1/2" Bsp F	
60.0550.50	400	5800	450	6500	-	-	80	21	1210	1/2" NPT F	

## **DIMENSIONAL DRAWING**

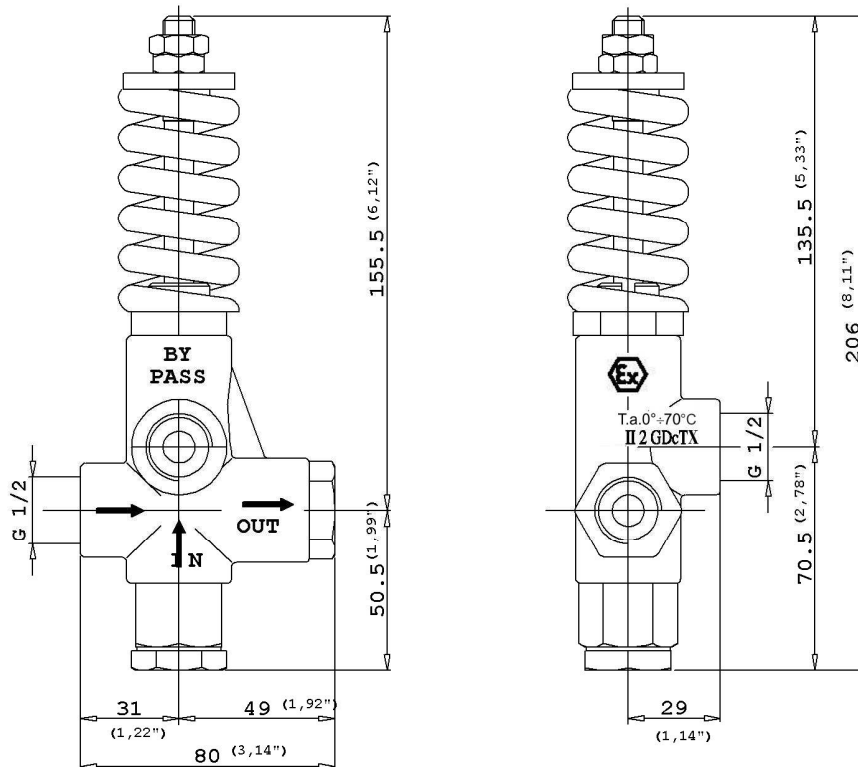

### **SELECTION**

This product is to be utilized with clean fresh water, even slightly additivated with normal detergents. For use involving different or corrosive liquids, contact the PA Technical department. Appropriate filtration should be installed when using impure liquids. Choose the valve in line with the working data of the machine where to be installed (permissible pressure, maximum flow rate and rated temperature of the system). In any case, any over-pressure of the machine must not exceed the permissible pressure marked on the valve.

### **OPERATION**

The valve limits the maximum pressure of the system. In the event of over-pressure, this relief valve will open to allow the liquid to by-pass. During normal system operation, a shutter driven by a spring will keep the bypass opening close. The set valve pressure can be regulated by adjusting the spring load by means of the dedicated adjusting screw.

### **INSTALLATION**

This product is intended to be incorporated on a finished machine. On a machine that produces hot water, this valve must be fitted upstream the heat generator. In addition it is recommended to install devices that limit the fluid temperature accidental increase.

### **DISCHARGE SYSTEM AND WATER ADDUCTION**

It is advisable to direct the bypass discharge liquid to a baffled tank that will reduce possible turbulence and air bubbles generated by the immission of the bypass flow, which could be harmful for the pump.

When large flow volumes, close to the max flow rate, are used, it is not advisable to return the bypass liquid to the pump as this may cause dangerous pressure spikes, dangerous for the pump.

### **PRESSURE ADJUSTMENT/SETTING**

The valve is supplied without pressure setting. The setting is done with the system "on" and with pressure inside the circuit. The valve setting pressure is achieved by operating on the adjusting screw (pos.9): by screwing it, the set pressure will increase. Once the desired pressure is attained, block the screw by locking the counter nut (pos.7)

## **TROUBLESHOOTING**

<b>PROBLEMS</b>	<b>PROBABLE CAUSES</b>	<b>SOLUTIONS</b>
Leaking out the bypass port during normal system operation.	- Seat or shutter is worn. - Foreign material is jammed between seat and shutter.	- Replace. - Clean.
	- System working pressure is above the set pressure.	- Re-set the system pressure.

## **REGULATIONS**

See Norms Manuals.

The accessory hereby described bears the CE marking in accordance with the standards and directives published in the Declaration of conformity.

For a correct utilization, follow the directions described in this manual and re-print them on the Use and Maintenance manual of the machine. If needed, ask for the original Conformity Declaration for the chosen accessory.

The present manual is valid for all unloader valves named **VS 80/400 INOX 303 ATEX**.

T.a.0÷70° C

**CE**  **II 2 GD c TX**

ATEX marking (see ATEX norms manual, PN: 10.9408.06)

## **SERVICING**

The safety valve useful life is 10 years with general inspection and service after 5 years.

The life duration depends from the working conditions such as type of fluid, ambient and operating conditions (pressure and temperature).

PA recommends to regularly service the safety valves every two years.

**Any unauthorized servicing operation will cause the interruption of any "PA" responsibility and warranty on the product.**

*Technical data, descriptions and illustrations are indicative and liable to modification without notice.*

<b>Instruction manual, maintenance, installation, spare parts.</b> For a correct utilization, follow the directions of this manual. <b>Re-print them on the use and maintenance booklet of the machine.</b>	n. 12.9221.00

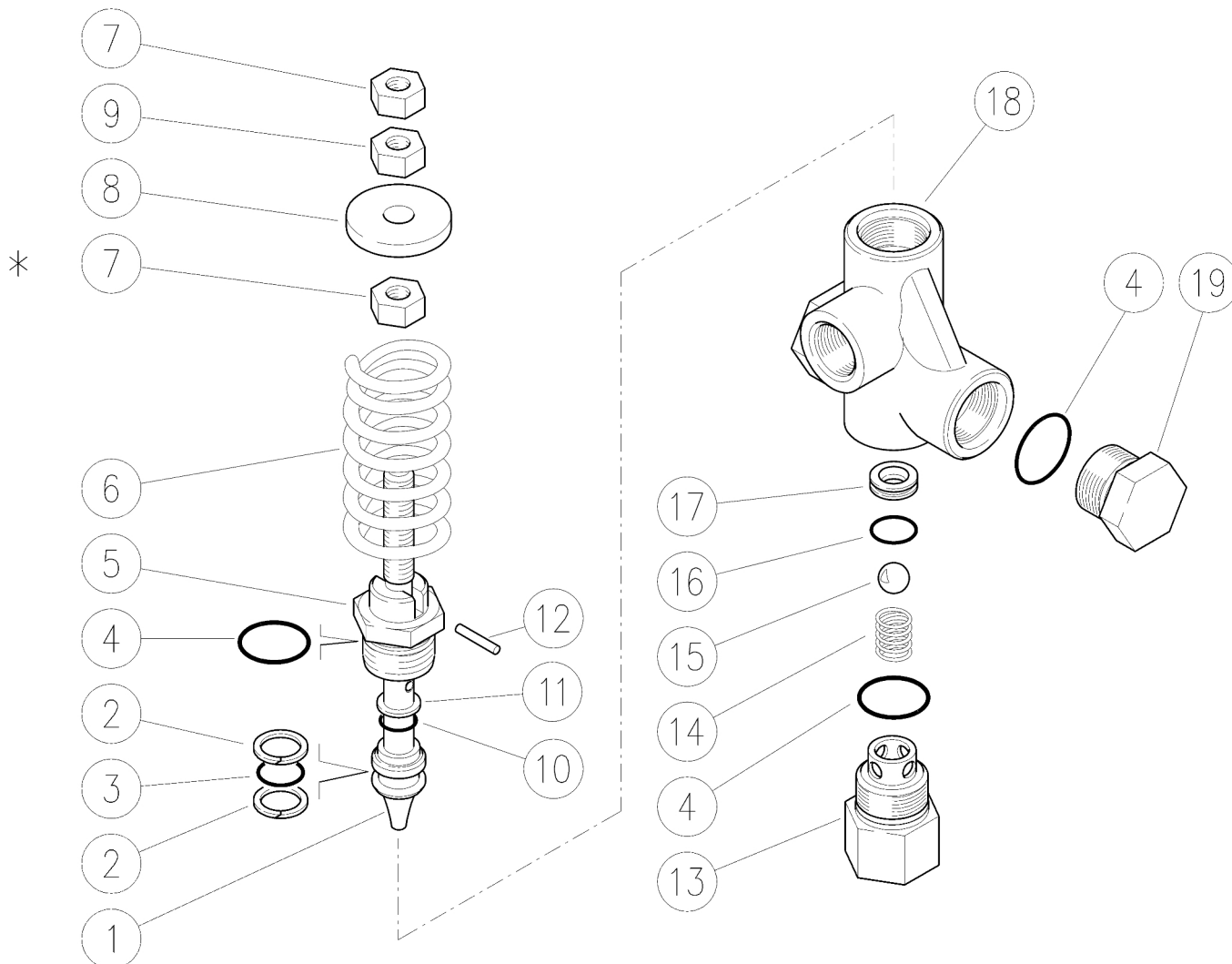

Pos.	P/N	Description	Q.ty	K1	K2	K3	K4	
1	60.0432.51	Piston, M10 Sst.	1					3
2	10.4014.00	Back-up ring, opn. 18x13,5x1,2 mm	2	•				10
3	10.3178.01	O-ring, 2,62x13,1 mm Ni 85	1	•				10
4	10.3072.01	O-ring, 1,78x20,35 mm Ni 85	3	•				10
5	60.0433.51	Stem holder, Sst.	1					5
6	60.0434.61	Spring, 8,5x38x80 mm black	1					3
7	11.4629.00	Hex. nut, M10	2					10
8	60.0406.31	Spring holding washer, brass	1					10
9	11.4630.00	Hex. nut, M10	1					10
10	10.3174.01	O-ring, 2,62x9,93 mm Ni 85	1	•				10
11	10.4015.00	Back-up ring, 10x14,5x1,2 mm	1	•				10

Pos.	P/N	Description	Q.ty	K1	K2	K3	K4	
12	15.1032.00	Roll pin, 3x18 mm Sst.	1					10
13	60.0405.51	Suction coupl., 1/2F Bsp Sst.	1					3
13	60.0438.51	Suction coupl., 1/2"Npt Sst. (1)	1					3
14	60.0410.51	Spring, 1,6x11,5x20 mm Sst.	1					5
15	14.7461.00	Ball, 13/32" Sst.	1	•				10
16	10.3060.01	O-ring, 1,78x12,42 mm Ni 85	1	•				10
17	60.0408.51	Seat, 8,5x15,9x4,5 mm Sst.	1	•				5
18	60.0431.55	Housing -VB80, 1/2F Bsp Sst.	1					3
18	60.0436.55	Housing -VB80, 1/2F Npt Sst. (1)	1					1
19	60.0552.51	Plug, sst. M24x1,5, hex.27	1					5

Kit	P/N	Description	
K1	60.0554.24	Spares kit -VS80/400, 8x5pcs.	1

(1) 60.0550.50



# PIJTTERSEN



The Pumps with Nine Lives

Pijtersen B.V.  
 Beneluxweg 33  
 9636 HV Zuidbroek  
 Tel.: +31(0)50-8200963

KvK 01013855  
 BIC RABONL2U  
 BTW NL002166811B01  
 IBAN NL24 RABO 0353 2970 97

www.pijtersen.nl - info@pijtersen.nl | www.catpumps.nl - info@catpumps.nl