



PIJTTERSEN

E-mail : info@pijtersen.nl / info@catpumps.nl
Internet: www.pijtersen.nl / www.catpumps.nl



Stainless Steel Captive Acceleration Tube

C.A.T. Models 711500
 714500
 717500

FEATURES

- Flexible tube absorbs energy from a positive head to increase liquid acceleration which significantly reduces cavitation and resulting potentially damaging system surges or hydraulic spikes.
- Eliminates wear producing shocks to the system components especially when high temperature, booster pump feed, long inlet lines or quick coupling valves exist.
- Maintains consistent inlet pressure and prolongs life of pump.
- Compact, simple design permits versatile, easy installation and requires minimal maintenance.

SELECTION: Select a C.A.T. tube with a flow range to match the system flow and the pump inlet connection. Various adapters are available to accommodate the various pump inlet connections.

INSTALLATION: For optimum performance, install the C.A.T. directly into the inlet manifold of the pump and support it from the base plate. Select the correct adapter that matches the pump inlet size. **Note:** Bent fitting requires a standard adapter to properly connect to pump. Apply Liquid Gasket to the o-ring groove and press the flanged end of the adapter (o-ring and retaining ring come on the adapter) into the C.A.T. until completely seated. Secure the retaining ring in the groove of the C.A.T. Apply sealant to the adapter threads. With a wrench thread assembly into pump inlet port. **CAUTION:** Do not over tighten. Because the adapter rotates within the C.A.T. end, there is no risk of twisting the internal hose.

SPECIFICATIONS

	U.S. Measure	Metric Measure
MODEL 711500		
Flow Range	up to 15 GPM	(up to 57 L/M)
Active Tube Fitting	1-1/2"	(38 mm)
Weight (Base Model)	1.3 lbs.	(0.60 kg)
MODEL 714500		
Flow Range	up to 45 GPM	(up to 170 L/M)
Active Tube Fitting	2-1/2"	(63.5 mm)
Weight (Base Model)	4.0 lbs.	(1.80 kg)
MODEL 717500		
Flow Range	up to 75 GPM	(up to 284 L/M)
Active Tube Fitting	3"	(75 mm)
Weight (Base Model)	4.8 lbs.	(2.20 kg)

COMMON SPECIFICATIONS

Inlet Pressure	2 to 50 PSI	(0.1 to 3.5 BAR)
Temperature*	208°F	(98°C)

*Do not exceed rated pump temperature. See individual pump specification sheets for maximum temperature of each model.

OPERATION: The C.A.T. tube is designed to maintain consistent inlet pressure to the pump and prevent pressure fluctuations which may be present due to long feed lines, high temperature liquids or booster pumps. **It will not eliminate or correct starvation (lack of sufficient liquid to the pump) and will not function with a suction lift.**

MAINTENANCE: With each seal and valve change, check all fitting connections for any leaks. Low pressure, fluctuating pressure or vibration are often the result of poor connections. Use PTFE thread tape or pipe thread sealant, but stop before the last thread.

“Customer confidence is our greatest asset”

C.A.T. DIMENSIONAL

Nominal Dimensions (mm)

	X	Y	Z			
711500	243	60	75			
714500	405	85	102			
717500	486	95	120			
To Fit 711500	A	B	C	D	E	F
711502	40	27	1/2" NPT	—	—	—
711503	40	27	3/4" NPT	—	—	—
711504	40	27	1" NPT	—	—	—
711505	48	36	1-1/4" NPT	—	—	—
711506	48	36	1-1/2" NPT	—	—	—
711512	48	36	1" BSP	—	—	—
711511	48	36	1-1/2" BSP	—	—	—
701818	—	—	1-1/2" Elbow	60	68	48
To Fit 714500						
714504	50	46	1" NPT	—	—	—
714505	50	46	1-1/4" NPT	—	—	—
714506	50	46	1-1/2" NPT	—	—	—
714508	50	27	2" NPT	—	—	—
714511	50	27	2" BSP	—	—	—
701828	—	—	2-1/2" Elbow	66	87	76
To Fit 717500						
717508	56	55	2" NPT	—	—	—
717510	56	60	2-1/2" NPT	—	—	—
717511	56	60	2-1/2" BSP	—	—	—
701833	—	—	3" Elbow	82	104	89

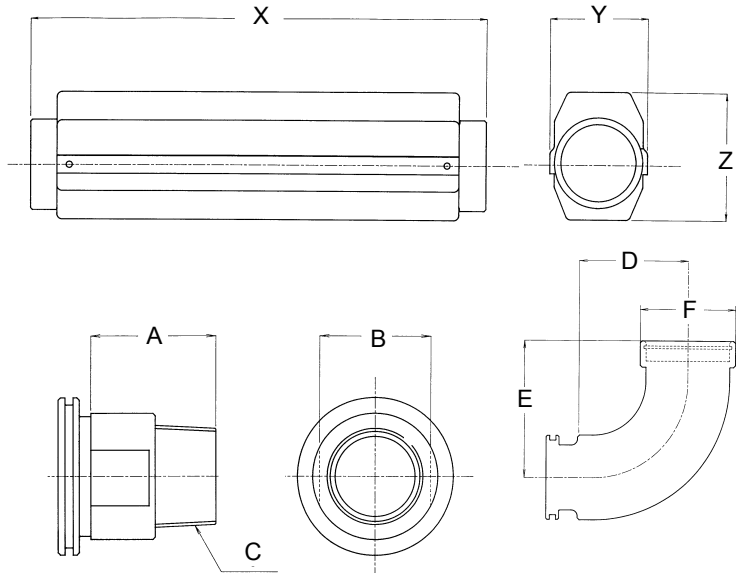

D=Distance from end of C.A.T. X=Extension from end of C.A.T.



TYPICAL INSTALLATION

Piston Pump

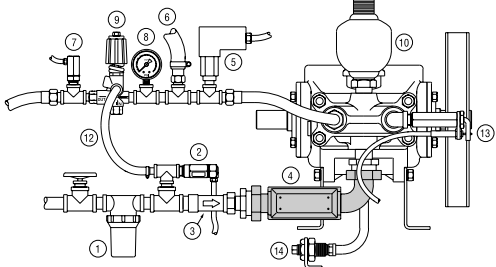

Plunger Pump

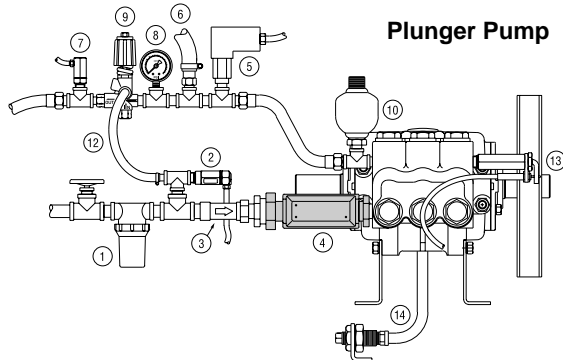

For best results the C.A.T. must be mounted directly to the pump inlet port.

These illustrations show the basic elements for a typical installation of a high pressure piston or plunger pump. **Not all components shown are required for all applications or systems.** Each component presents potential problems that too often are ascribed to a perfectly functioning pump, such as: a clogged strainer, a partially closed shut-off valve, a faulty gauge, or a malfunctioning regulator/unloader. Proper system installation, routine lubrication, monitoring and maintenance of components are your basic guarantees of optimum pump performance. CAT PUMPS does not assume any liability or responsibility for the design or operation of a customer's high pressure system.

- | | |
|--------------------------------------|----------------------------------|
| 1 Inlet Filter | 8 Pressure Gauge |
| 2 Thermo Valve | 9 Pressure Regulator/Unloader |
| 3 Inlet Pressure Regulator | 10 Pulsation Dampener* |
| 4 C.A.T. (Captive Acceleration Tube) | 11 Chemical Injector (Not Shown) |
| 5 Pressure Switch | 12 By-Pass Hose |
| 6 Pop-Off Valve | 13 Throttle Controller |
| 7 Quick Start Valve | 14 Oil Drain Kit |

*Preferred mounting of Pulsation Dampener [Prrrrr-O-Lator] is directly on the discharge manifold of the pump. The preferred mounting of the by-pass hose [when returning to the inlet] is before the Pressure Reducing Valve. If this is not possible, then mount the Prrrrr-O-Lator after the Pressure Unloading Valve to prevent pressure spikes to the pump inlet.

SIMPLE C.A.T. TUBE STOPS PUMP CAVITATION

APPLIED LIQUID MECHANICS.

The technology of the Captive Acceleration Tube (C.A.T.) is an application of liquid mechanics that has been refined over the last 20 years in the U.K. and overseas. The following is a glimpse of the technology behind the C.A.T.

WHAT IS CAVITATION?

Cavitation in piston and plunger pumps is caused by the formation and collapse of gaseous cavities in the liquid being pumped and it is the energy of the collapse during the suction stroke which erodes the surfaces of the pump.

The most obvious indication of cavitation is a **hammering noise**. This noise can be either continuous or intermittent depending upon the degree of cavitation. **Vibration** of the pump and system will also be noticeable as the pump becomes starved of liquid. Eventually **flow and pressure will decrease**.

WHAT IS A C.A.T.?

A C.A.T. is an energy source that releases energy at the frequency needed to ensure that the cylinders are filled from the beginning of the stroke. Once this is achieved, the risk of cavitation is virtually eliminated. Inlet Pulsation Dampeners have been tried as a cure but while they may reduce top of inlet pressure spikes, especially with low speed pumps,

they do nothing to relieve the cavitation regime. A C.A.T., on the other hand, kicks liquid into the cylinder at the required frequency to match the opening of inlet valves of even high speed pumps.

The C.A.T. is not designed for suction inlet conditions as the energy storing hose inside will collapse and be dysfunctional.

WHAT SYSTEMS BENEFIT MOST?

Although most installations of piston and plunger pumps will benefit from a C.A.T., those most in need of one are where the **inlet pressure is boosted**, where the **inlet temperature is high** (over 120°F) and where the **inlet line is long or tortuous**.

HOW MUCH COULD BE GAINED?

Here are solid facts of what the C.A.T. has achieved for some systems.

In one installation containing two pumps, the annual costs of spares is now only \$176.00 for each pump. this showed a savings of over 90%.

In yet another case, the yearly cost of spares fell from \$1600.00 to \$240.00

Remember, C.A.T.s are not a gimmick and their cost is not an insignificant part of the price of a pump package. We offer them with the absolute certainty that they will perform the "miracles" we promise when installed properly.

Spiking Pump Cavitation

A simple piece of lateral thinking has solved the cavitation problems which can plague piston and plunger pumps. Essentially the solution is a piece of flexible hose which gives a boost as the inlet valve opens. but the effects are dramatic. The director of *CAT PUMPS (UK)* who perfected the concept quotes examples in pumping and water hydraulics where the C.A.T. (captive acceleration tube) has cut maintenance costs by 90%.

The real trick as ever was in isolating the right problem. The design began with work on reverse osmosis systems producing fresh water at sea. There, centrifugal pumps were being used to boost the flow into the main positive displacement pumps (PDP). Where the two were not in tune, cavitation became an horrendous problem unless mammoth pumps were used at low speeds.

The inlet to the PDP was at the heart of the difficulty. If, when the inlet valve opens there is not an immediate flow to the cylinder, then a low pressure regime is followed by a sudden pressure spike rushing in to fill the gap. Traditional solutions had attempted to cut off the top of the pressure spike using an inlet pulsation dampener. However, this was merely treating the symptoms, which in fact follow the low pressure regime, not curing the cause.

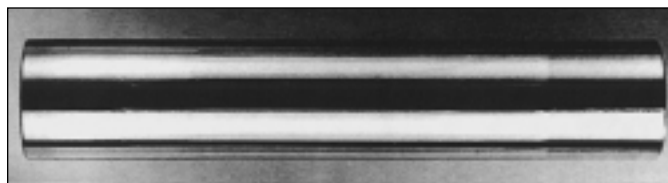

Mild Cavitation

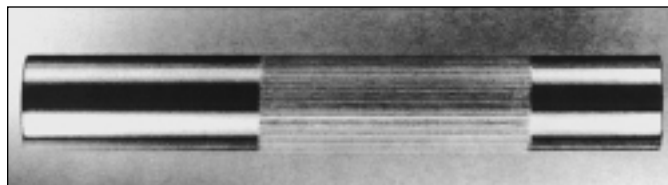

Severe Cavitation

The mechanism by which cavitation damages pumps is complex. The pressure drop forms pockets of vapor in the liquid, which therefore gain latent heat of vaporization. When a vapor pocket touches a metal surface, it loses this heat instantaneously and implodes. The resulting shock wave bounces off an adjacent surface, pulling metal molecules with it. The resulting damage (above) could be mistaken for severe abrasive wear, but can occur no matter how pure the liquid being pumped.

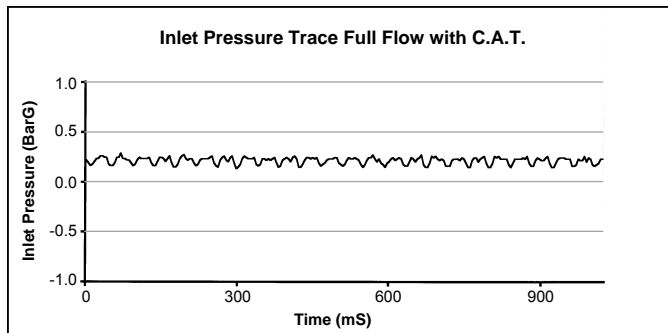
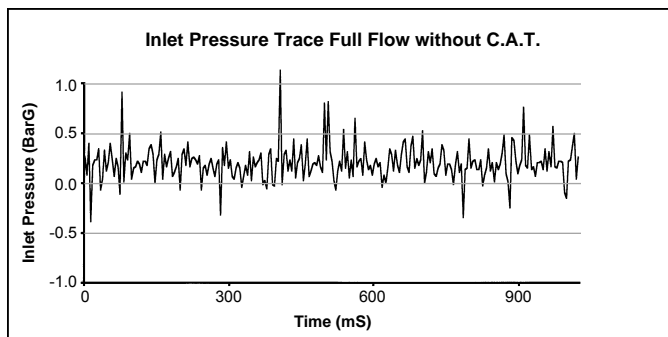

Instead the need was to "kick" the flow into the inlet as soon as it opened to avoid the cylinder running on empty, early on its stroke. Once that has happened, the flow neatly follows demand in a smooth curve with no cavitation and no pressure spike (see graph).

The C.A.T. system uses a piece of flexible hose, which expands slightly, ready to provide this acceleration at the critical inlet opening point. The painstaking part which took twenty years, was to balance hose size and pump frequency.

Main beneficiaries are likely to be in cases where a boost pump is used; where high inlet temperature (over 50°C) lowers vapor pressure at the inlet; and where tortuous inlet lines slow flow acceleration. It cannot be used though where pumps suck or for pressure over 50 psi.

One clear application is in water hydraulics, notably in several British Steel mills. An earlier example at Morganite Crucible, on its hydrostatic press for cold forming pipe fittings illustrates the point. Two triplex plunger pumps replaced gear pumps early in 1985, running periodically at 782 rpm with a 95/5 liquid and pressure to 140 bar. Spares usage after nearly four years only amounted to \$900. The gear pumps were being replaced every three months.

EXPLODED VIEW

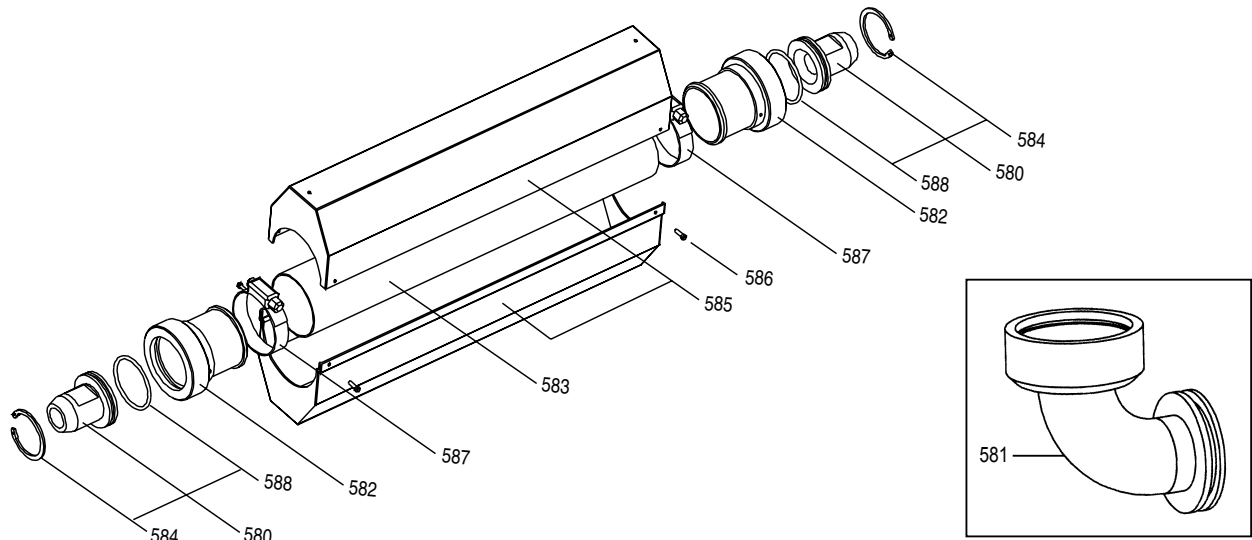

PARTS LIST

ITEM	DESCRIPTION	MODEL 711500		MODEL 714500		MODEL 717500		QTY
		MODEL	MATL	MODEL	MATL	MODEL	MATL	
580	Adapter, Assy, Straight (1/2") [Incls: 584, 588]	711502	SS	—	—	—	—	1-2
	Adapter, Assy, Straight (3/4") [Incls: 584, 588]	711503	SS	—	—	—	—	1-2
	Adapter, Assy, Straight (1") [Incls: 584, 588]	711504	SS	714504	SS	—	—	1-2
	Adapter, Assy, Straight (1-1/4") [Incls: 584, 588]	711505	SS	714505	SS	—	—	1-2
	Adapter, Assy, Straight (1-1/2") [Incls: 584, 588]	711506	SS	714506	SS	—	—	1-2
	Adapter, Assy, Straight (1" BSP) [Incls: 584, 588]	711512	SS	—	—	—	—	1-2
	Adapter, Assy, Straight (1-1/2" BSP) [Incls: 584, 588]	711511	SS	—	—	—	—	1-2
	Adapter, Assy, Straight (2") [Incls: 584, 588]	—	—	714508	SS	717508	SS	1-2
	Adapter, Assy, Straight (2" BSP) [Incls: 584, 588]	—	—	714511	SS	—	—	1-2
	Adapter, Assy, Straight (2-1/2") [Incls: 584, 588]	—	—	—	—	717510	SS	1-2
	Adapter, Assy, Straight (2-1/2" BSP) [Incls: 584, 588]	—	—	—	—	717511	SS	1-2
581	Elbow, Assy, (1-1/2") [Incls: 584, 588]	701818	SS	—	—	—	—	1-2
	Elbow, Assy, (2-1/2") [Incls: 584, 588]	—	—	701828	SS	—	—	1-2
	Elbow, Assy, (3") [Incls: 584, 588]	—	—	—	—	701833	SS	1-2
582	Barb, Hose, Internal	701816	SS	—	SS	701831	SS	2
583	Hose, Internal (1.5" x 7.48")	701819	PPB	—	—	—	—	1
	Hose, Internal (2.5" x 12.87")	—	—	701829	PPB	—	—	1
	Hose, Internal (3.0" x 16.55")	—	—	—	—	701839	PPB	1
584	Ring, Retaining (Internal)	701767	STNP	701768	STNP	701769	STNP	2
585	Cover, Pair	701815	PVC	701825	PVC	701830	PVC	1
586	Screw, Self Tap (M3x8, M3x10)	701766	SS	701877	SS	701877	SS	4
587	Hose Clamp	701810	S	701820	S	701840	S	2
588	O-Ring, Adapter	701817	NBR	701827	NBR	701832	NBR	2
—	Pliers, Snap Ring (1.5", 3.5")	33285	STL	33285	STL	33285	STL	1

MATERIAL CODES (Not Part of Part Number):

NBR=Medium Nitrile (Buna-N) PPB=PVC+Polyester+Butyl PVC=Polyvinyl Chloride S=304SS SS=316SS STL=Steel STNP=Steel/Nickel Plated

NOTE: Elbow requires standard straight fitting to properly connect.

TROUBLESHOOTING

Water leaking at adapter connection.

- Worn or missing O-Ring.

Water leaking from the cover ends.

- Cracked or worn hose or improperly tightened clamps.

WARRANTY

90 Day Warranty

Refer to complete CAT PUMPS Warranty for further information.



PIJTTERSEN

Pijtersen B.V.
Beneluxweg 33
9636 HV Zuidbroek
Tel.: +31(0)50-8200963

KvK 01013855
BIC RABONL2U
BTW NL002166811B01
IBAN NL24 RABO 0353 2970 97

www.pijtersen.nl - info@pijtersen.nl | www.catpumps.nl - info@catpumps.nl