

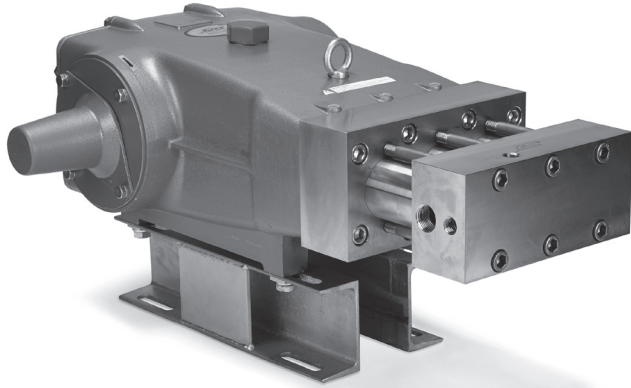

PIJTTERSEN
 E-mail : info@pijtersen.nl / info@catpumps.nl
 Internet: www.pijtersen.nl / www.catpumps.nl



68 Frame Block-Style 10K Stainless Steel Plunger Pump

Model 6810

FEATURES

- Triplex plunger design delivers high efficiency and low pulsation.
- V-Packings and low pressure seals are completely lubricated and cooled by pumped liquid.
- Low upswept volume maximizes volumetric efficiency.
- Special high-density, polished, concentric ceramic plungers provide a true wear surface and extended seal life.
- Wet-end is easily serviced without entering crankcase.

SPECIFICATIONS

	U.S. Measure	Metric Measure
Flow	10.0 gpm	(38 lpm)
Pressure Range	100 to 10,000 psi	(7 to 689 bar)
Inlet Pressure Range	Flooded to 50 psi	(Flooded to 3.5 bar)
Max. RPM	600 rpm	(600 rpm)
Bore	0.827"	(21 mm)
Stroke	2.579"	(65.5 mm)
Crankcase Capacity	10 Qts.	(9.46 l)
Maximum Liquid Temperature	140°F	(60°C)
Above 130°F call Cat Pumps for inlet conditions and elastomer recommendations.		
Inlet Ports (2)	1" NPTF	(1 NPTF)
Discharge Ports (3)	1/2" NPTF	(1/2" NPTF)
Shaft Diameter	1.772"	(45 mm)
Weight	377.4 lbs.	(171.5 kg)
Dimensions	31.75 x 24.02 x 11.12"	(806 x 610 x 282 mm)

⚠ CAUTIONS AND WARNINGS

All High Pressure Systems require a primary pressure regulating device (i.e. regulator, unloader) and a secondary pressure relief device (i.e. pop-off valve, relief valve). Failure to install such relief devices could result in personal injury or damage to pump or property. CAT PUMPS does not assume any liability or responsibility for the operation of a customer's high pressure system.

Read all CAUTIONS and WARNINGS before commencing service or operation of any high pressure system. The CAUTIONS and WARNINGS are included in each service manual and with each Accessory Data sheet. CAUTIONS and WARNINGS can also be viewed online at www.catpumps.com/cautions-warnings or can be requested directly from CAT PUMPS.

WARRANTY

View the Limited Warranty on-line at www.catpumps.com/warranty.

ELECTRIC HORSEPOWER REQUIREMENTS

FLOW		PRESSURE			RPM
		psi 5000	psi 7500	psi 10000	
U.S. gpm	lpm	bar 345	bar 517	bar 689	
10	38	34.2	51.4	68.5	600
5	19	17.1	25.7	34.2	300

DETERMINING THE PUMP R.P.M. $\frac{\text{Rated gpm}}{\text{Rated rpm}} = \frac{\text{"Desired" gpm}}{\text{"Desired" rpm}}$

DETERMINING THE REQUIRED H.P. $\frac{\text{gpm} \times \text{psi}}{1460} = \text{Electric Brake H. P. Required}$

DETERMINING MOTOR PULLEY SIZE $\frac{\text{Motor Pulley O.D.}}{\text{Pump rpm}} = \frac{\text{Pump Pulley O.D.}}{\text{Motor rpm}}$

See complete Drive Packages [Incls: Pulleys, Belts, Hubs, Key] Tech Bulletin 003.
 Refer to pump Service Manual for repair procedure and additional technical information.

PARTS LIST

ITEM	PART NUMBER	MATL	DESCRIPTION	QTY
2	43048	STL	Key (M14x9x90)	1
5	89728	S	Screw, HH (M10x40)	8
6	15847	S	Lockwasher (M10)	8
7	19934	S	Washer, Flat (M10)	8
8	29443	AL	Cover, Bearing, Outer	2
10	29444	NBR	O-Ring, Bearing Cover - 70D	2
11	11443	NBR	Seal, Oil, Crankshaft - 70D	2
12	126594	STCP R	Washer, Shim (M120x0.3)	0-2
13	126595	STCP R	Washer, Shim (M120x0.5)	0-2
15	29441	STL	Bearing, Roller	2
16	29442	STL	Cover, Bearing, Inner	2
17	29444	NBR	O-Ring, Bearing Cover - 70D	2
20	126612	BBHS	Assembly, Connecting Rod (Incls: 21, 22)	3
21	126560	STCP R	Washer, Locking	3
22	126593	STCP R	Washer, Shim (M10.5x1.5)	6
25	29440	FCM	Crankshaft, Dual Shaft	1
31	828710	—	Protector, Oil Cap w/Foam Gasket	1
32	43211	ABS	Cap, Oil Filler	1
33	14177	NBR	O-Ring, Filler Cap - 70D	1
34	126743	STCP R	Bolt, Eye (M12) (For Lifting Pump Only)	1
38	129343	RBR	Gasket, Flat Flex	1
39	49948	ABS	Stick, Dip	1
40	89627	S	Screw, HH (M10x30)	8
41	15847	S	Lockwasher (M10)	8
42	19934	S	Washer, Flat (M10)	8
48	25625	STCP	Plug, Drain (1/4"x19BSP)	1
49	23170	NBR	O-Ring, Drain Plug - 70D	1
50	29438	AL	Cover, Rear	1
51	129386	NBR	Gasket, Rear Cover	1
53	45303	AL	Crankcase (Incls: 34, 54)	1
54	43282	S	Pin, Guide	2
64	29481	CM	Pin, Crosshead	3
65	48735	SSZZ	Rod, Plunger	3
69	126588	STCP R	Washer, Oil Seal	3
70	29454	NBR	Seal, Oil Crankcase - 80D	3
75	43865	S	Slinger, Barrier	3
90	76347	CC	Assembly, Plunger (M21)	3
95	76344	S	Stud (M10x22)	3
100	703084	D	Retainer, Seal	3
106	76313	ST4	Seal, LPS	3
110	76348	S	Block, Housing	1
117	76358	S	Screw, HSH (M16x100)	8
121	76318	PTFE	Ring, Cylinder Sealing	9
122	76327	NBR	O-Ring, Front Cylinder	3
123	76317	NBR	O-Ring, Rear Cylinder	3
124	76321	S	Cylinder	3
127	76314	UHMW	Assembly, V-Packing w/BZ Cylinder Support	3
134	76359	S	Valve, Inlet	3
135	76322	D	Retainer, Spring	3
136	76324	S	Spring	3
164	76337	S	Seat, Ball Assembly w/Ceramic Ball	3
185	76338	S	Manifold, Inlet/Discharge, Block Style	1
188	76377	S	Screw, HSH (M16x200)	6
250	29445	AL	Protector, Shaft	1
255	33243	STZP	Kit, Mount (Included w/Pump)	2
259	126604	STCP R	Rail, Box (Included w/Pump)	2
275	990014	STL	Hub, "B", M45 w/Keyway [See Tech Bulletin 003]	1
283	34314	—	Kit, Oil Drain (3/8" x 48")	1
290	6124	—	Gasket, Liquid (3 oz.)	1
299	996810	S	Head, Complete, Block-Style	1
300	76966	ST4	Kit, Seal (Incls: 106,121,122, 123,127)	1
310	76967	S	Kit, Valve (Incls: 121,122, 123,134, 136, 164)	2
—	819010	F	Assy, Crankcase, Cast Iron Conversion	1
—	6105	—	Oil, Twin Pack (Two-2.5 Gal) ISO-68 Hydraulic (Fill to specified crankcase capacity prior to start-up)	1
—	6119	—	Lubricant, Antiseize (2 oz.)	1

Italics are optional items. R Components comply with RoHS Directive.

See Tech Bulletins 003, 024, 036, 074, 077, 083, 084, 087, 095 and 105 for additional information. C.A.T. highly recommended for pressurized inlet, R.O. and Industrial applications.

MATERIAL CODES (Not Part of Part Number): ABS=ABS Plastic AL=Aluminum BBHS=Brass/High Strength CC=Ceramic CM=Chrome-Moly

D=Acetal F=Cast Iron FCM=Forged Chrome-Moly NBR=Medium Nitrile (Buna-N)PTFE=Pure Polytetrafluoroethylene

S=304SS SS=316SS SSZZ=316SS/Zamak ST4=Special PTFE 4 STCP=Steel/Chrome Plated STCP=Steel/Chrome Plated STL=Steel

STZP=Steel/Zinc Plated UHMW=Ultra High Molecular Polyethylene

EXPLODED VIEW

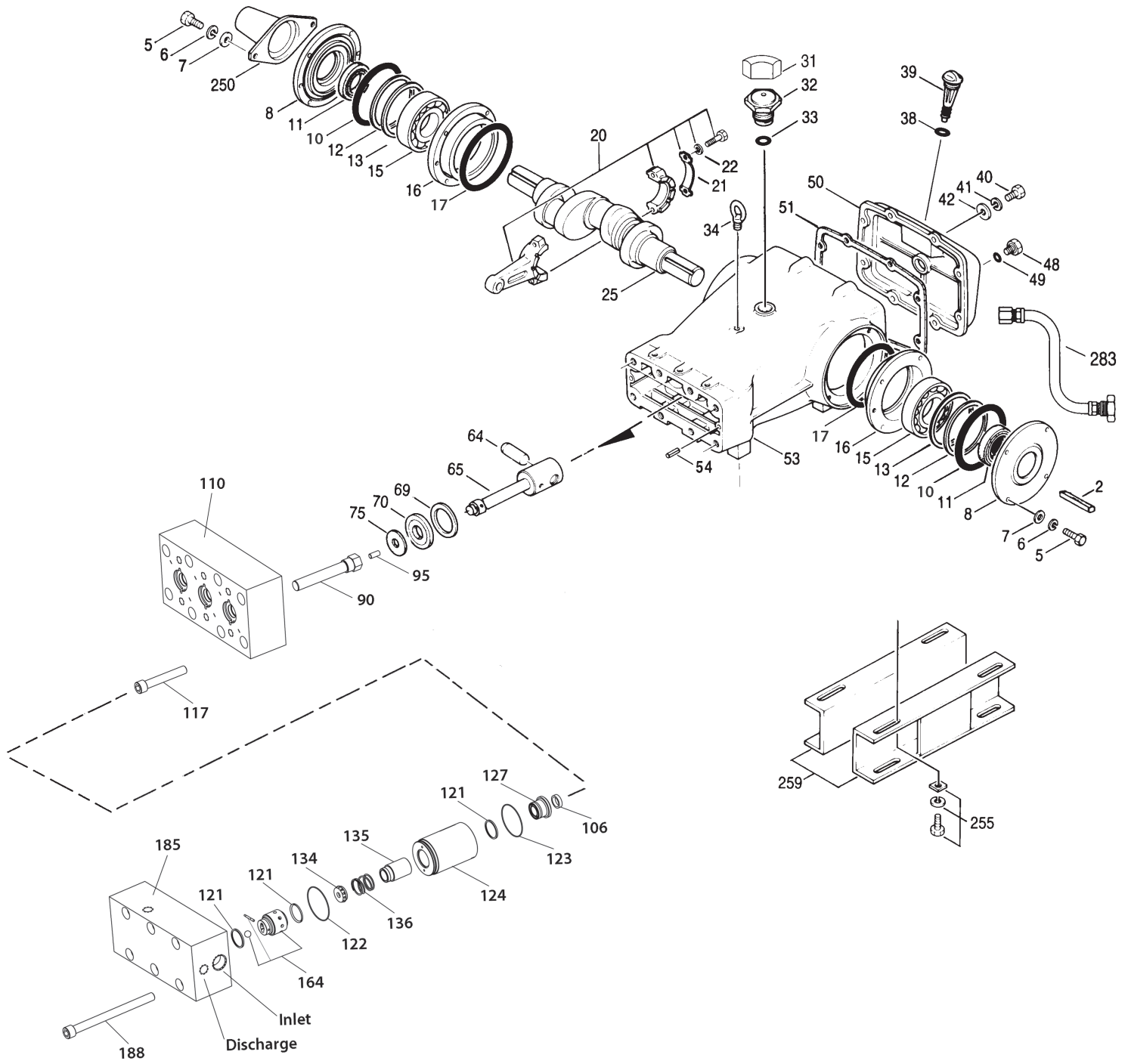

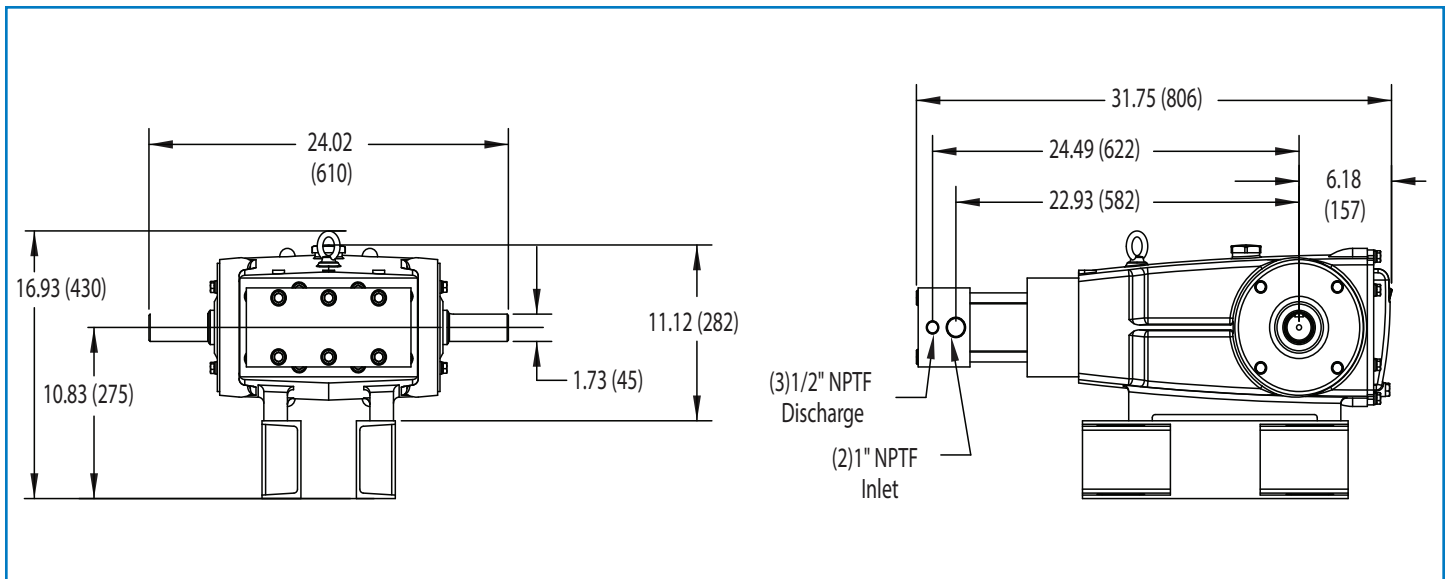

Model 6810



PIJTTERSEN



The Pumps with Nine Lives

Pijtersen B.V.
 Beneluxweg 33
 9636 HV Zuidbroek
 Tel.: +31(0)50-8200963

KvK 01013855
 BIC RABONL2U
 BTW NL002166811B01
 IBAN NL24 RABO 0353 2970 97

www.pijtersen.nl - info@pijtersen.nl | www.catpumps.nl - info@catpumps.nl