

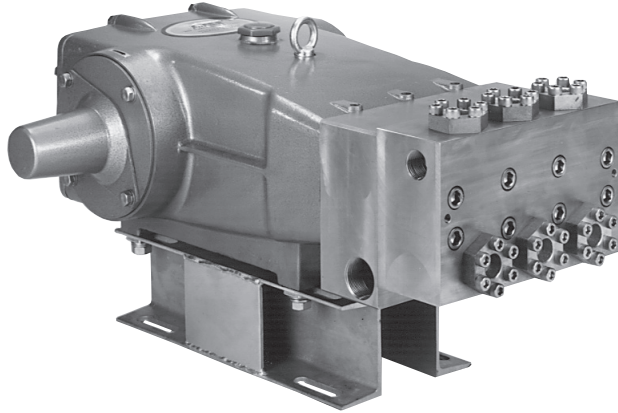

PIJTERSEN

E-mail : info@pijtersen.nl / info@catpumps.nl
 Internet: www.pijtersen.nl / www.catpumps.nl



68 Frame Block-Style Stainless Steel Plunger Pump

**Standard
Models**

6831

**Flushed
Models**

6831K

FEATURES

Triplex plunger design delivers high efficiency and low pulsation.

Durable dual V-Packings are lubricated and cooled by pumped liquid.

Pre-Set Lo-Pressure seals provide secondary protection against external leaks and require no packing adjustment.

Special high-density, polished, concentric ceramic plungers provide a true wear surface and extended seal life.

Specially formulated seals and V-Packings offer unmatched performance and seal life.

Wet-end is easily serviced without entering crankcase.

SPECIFICATIONS

	U.S. Measure	Metric Measure
Flow.....	40 gpm	(151 l/m)
Pressure Range.....	100 to 2300 psi	(7 to 160 bar)
Inlet Pressure Range*.....	Flooded to 50 psi	(Flooded to 3.5 bar)
Max. RPM.....	625 rpm	(625 rpm)
Bore.....	1.575"	(40 mm)
Stroke.....	2.579"	(65.5 mm)
Crankcase Capacity.....	10 Qts.	(9.46 l)
Maximum Liquid Temperature.....	140°F	(60°C)
Above 130F call Cat Pumps for inlet conditions and elastomer recommendations.		
Inlet Ports (2).....	1-1/2" NPTF	(1-1/2" NPTF)
Flushing Ports (2)*.....	1/2" NPTF	(1/2" NPTF)
Discharge Ports (2).....	1" NPTF	(1" NPTF)
Shaft Diameter.....	1.772"	(45 mm)
Weight.....	355 lbs.	(161 kg)
Dimensions.....	29.5 x 24.33 x 12.00"	(750 x 618 x 305 mm)

*Flushed K Models: Special ported inlet manifold permits an external flush liquid providing cooling for Hi-Temp liquids and lubrication with low lubricity liquids.

ELECTRIC HORSEPOWER REQUIREMENTS

FLOW		PRESSURE				RPM
		psi 1000	psi 1500	psi 2000	psi 2300	
U.S. gpm	l/m	bar 70	bar 105	bar 140	bar 160	
40	151	27.4	41.1	54.8	63.0	625
30	114	20.6	30.9	41.1	47.3	470
25	95	17.2	25.7	34.3	39.4	391
20	76	13.7	20.5	27.5	31.5	331

**DETERMINING
THE PUMP R.P.M.**

$$\frac{\text{Rated gpm}}{\text{Rated rpm}} = \frac{\text{"Desired" gpm}}{\text{"Desired" rpm}}$$

**DETERMINING
THE REQUIRED H.P.**

$$\frac{\text{gpm} \times \text{psi}}{1460} = \text{Electric Brake H. P. Required}$$

**DETERMINING
MOTOR PULLEY SIZE**

$$\frac{\text{Motor Pulley O.D.}}{\text{Pump rpm}} = \frac{\text{Pump Pulley O.D.}}{\text{Motor rpm}}$$

See complete Drive Packages [Incls: Pulleys, Belts, Hubs, Key] Tech Bulletin 003.
 Refer to pump **Service Manual** for repair procedure and additional technical information.

⚠ CAUTIONS AND WARNINGS

All High Pressure Systems require a primary pressure regulating device (i.e. regulator, unloader) and a secondary pressure relief device (i.e. pop-off valve, relief valve). Failure to install such relief devices could result in personal injury or damage to pump or property. CAT PUMPS does not assume any liability or responsibility for the operation of a customer's high pressure system.

Read all CAUTIONS and WARNINGS before commencing service or operation of any high pressure system. The CAUTIONS and WARNINGS are included in each service manual and with each Accessory Data sheet. CAUTIONS and WARNINGS can also be viewed online at www.catpumps.com/cautions-warnings or can be requested directly from CAT PUMPS.

WARRANTY

View the Limited Warranty on-line at www.catpumps.com/warranty.

PARTS LIST

ITEM	PART NUMBER				DESCRIPTION	QTY
	6831	MATL	6831K	MATL		
2	43048	STL	43048	STL	Key (M14x9x90)	1
5	89728	S	89728	S	Screw, HH (M10x40)	8
6	15847	S	15847	S	Lockwasher (M10)	8
7	19934	S	19934	S	Washer, Flat (M10)	8
8	29443	AL	29443	AL	Cover, Bearing, Outer	2
10	29444	NBR	29444	NBR	O-Ring,Bearing Cover - 70D	2
11	11443	NBR	11443	NBR	Seal, Oil, Crankshaft - 70D	2
12	43642	S	43642	S	Washer, Shim (M120x0.3)	0-2
	126594	STCP R	126594	STCP R	Washer, Shim (M120x0.3)	0-2
13	126595	STCP R	126595	STCP R	Washer, Shim (M120x0.5)	0-2
15	29441	STL	29441	STL	Bearing, Roller	2
16	29442	STL	29442	STL	Cover Bearing, Inner	2
17	29444	NBR	29444	NBR	O-Ring,Bearing Cover - 70D	2
20	126612	BBHS	126612	BBHS	Assembly, Connecting Rod (Incls: 21, 22)	3
21	126560	STCP R	126560	STCP R	Washer, Locking	3
22	126593	STCP R	126593	STCP R	Washer, Shim (M10.5x1.5)	6
25	29440	FCM	29440	FCM	Crankshaft, Dual Shaft	1
31	828710	—	828710	—	Protector, Oil Cap w/Foam Gasket	1
32	43211	ABS	43211	ABS	Cap, Oil Filler	1
33	14177	NBR	14177	NBR	O-Ring, Filler Cap - 70D	1
34	126743	STCP R	126743	STCP R	Bolt, Eye (M12) (For Lifting Pump Only)	1
38	129343	RBR	129343	RBR	Gasket, Flat Flex	1
39	27769	ABS	27769	ABS	Stick, Dip	1
40	89627	S	89627	S	Screw, HH (M10x30)	8
41	15847	S	15847	S	Lockwasher (M10)	8
42	19934	S	19934	S	Washer, Flat (M10)	8
48	25625	STCP	25625	STCP	Plug, Drain (1/4"x19B5P)	1
49	23170	NBR	23170	NBR	O-Ring, Drain Plug - 70D	1
50	29438	AL	29438	AL	Cover, Rear	1
51	129386	NBR	129386	NBR	Gasket, Rear Cover	1
53	45303	AL	45303	AL	Crankcase (Incls: 34, 54)	1
54	43282	S	43282	S	Pin, Guide	2
64	29481	CM	29481	CM	Pin, Crosshead	3
65	48735	SSZZ	48735	SSZZ	Rod, Plunger	3
69	126588	STCP R	126588	STCP R	Washer, Oil Seal	3
70	29454	NBR	29454	NBR	Seal, Oil, Crankcase - 80D	3
75	43865	S	43865	S	Slinger, Barrier	3
88	45676	S	45676	S	Washer, Keyhole (M16)	3
90	43921	CC	43921	CC	Plunger (M40x145)	3
95	89778	SS	89778	SS	Stud, Plunger Retainer (M10x135)	3
96	20189	PTFE	20189	PTFE	Back-up-Ring, Plunger Retainer	3
97	11345	NBR	11345	NBR	O-Ring, Plunger Retainer - 70D	3
	11375	FPM	11375	FPM	O-Ring, Plunger Retainer - 70D	3
98	44085	SS	44085	SS	Gasket, Plunger Retainer	3
99	44084	SS	44084	SS	Retainer, Plunger (M10)	3
100	703084	D	703084	D	Retainer, Seal	3
106	44113	NBR	44113	NBR	Seal, LPS, w/SS-Spg	3
	44740	FPM	44740	FPM	Seal, LPS, w/SS-Spg	3
108	45381	SS	45381	SS	Spacer, LPS	3
110	701321	SS	—	—	Manifold Inlet, Block-Style	1
	—	—	701322	SS	Manifold Inlet, Block-Style, Flushed	1
111	701116	SS	701116	SS	Plug, Inlet Manifold (1-1/2" NPTM)	1
112	701632	NBR	701632	NBR	O-Ring, Spacer	6
	701328	FPM	701328	FPM	O-Ring, Spacer	6
113	701329	PTFE	701329	PTFE	Back-up-Ring, Spacer	6
114	701327	SS	701327	SS	Spacer, Inlet	3
117	89694	S	89694	S	Screw, HSH (M16x110)	6
118	701077	SS	—	—	Plug (1/4" NPTM)	3
126	45367	SS	45367	SS	Adapter, Female	3
127	44609	STG*	44609	STG*	V-Packing	6
	44741	SFG	44741	SFG	V-Packing	6
128	704480	SS	704480	SS	Adapter, Male	3
155	48860	NBR	48860	NBR	O-Ring, V-Packing Spacer, Inner - 90D	3
	20137	FPM	20137	FPM	O-Ring, V-Packing Spacer, Inner - 70D	3
156	48362	D	48362	D	Back-up-Ring, V-Packing Spacer	6
157	45369	SS	45369	SS	Spacer, V-Packing	3
159	48860	NBR	48860	NBR	O-Ring, V-Packing Spacer, Outer - 90D	3
	20137	FPM	20137	FPM	O-Ring, V-Packing Spacer, Outer - 70D	3
160	44756	SS	44756	SS	Pin, Guide	2
162	48363	D	48363	D	Back-up-Ring, Seat	6
163	26142	NBR	26142	NBR	O-Ring, Seat - 80D	6
	14330	FPM	14330	FPM	O-Ring, Seat	6
164	44612	SS	44612	SS	Seat	6
166	44108	SS	44108	SS	Valve	6
167	44109	SS	44109	SS	Spring	6
168	44728	PVDF	44728	PVDF	Retainer, Spring	6
170	44729	SS	44729	SS	Washer, Retainer	6
171	44644	SS	44644	SS	Spring, Coil	6
172	89827	NBR	89827	NBR	O-Ring, Valve Plug - 90D	6
	11747	FPM	11747	FPM	O-Ring, Valve Plug - 90D	6
173	48364	D	48364	D	Back-up-Ring, Valve Plug	6
174	701432	SS	701432	SS	Plug, Valve	6
175	87951	S	87951	S	Screw, HSH (M10x30)	36
185	701431	SS	701431	SS	Manifold, Discharge, Block-Style	1
188	701279	S	701279	S	Screw, HSH (M12x100), Lower	4
193	89694	S	89694	S	Screw, HSH (M16x110), Upper	8
250	29445	AL	29445	AL	Protector, Shaft	1
255	33243	STZP	33243	STZP	Kit, Mount (Included w/Pump)	2
259	29477	STZP	29477	STZP	Rail, Box (Included w/Pump)	2
275	990014	STL	990014	STL	Hub, "B", M45, Keyway [See Tech Bulletin 003]	1
283	34314	—	34314	—	Kit, Oil Drain (3/8" x 48")	1
290	6124	—	6124	—	Gasket, Liquid (3 oz.)	1

EXPLODED VIEW

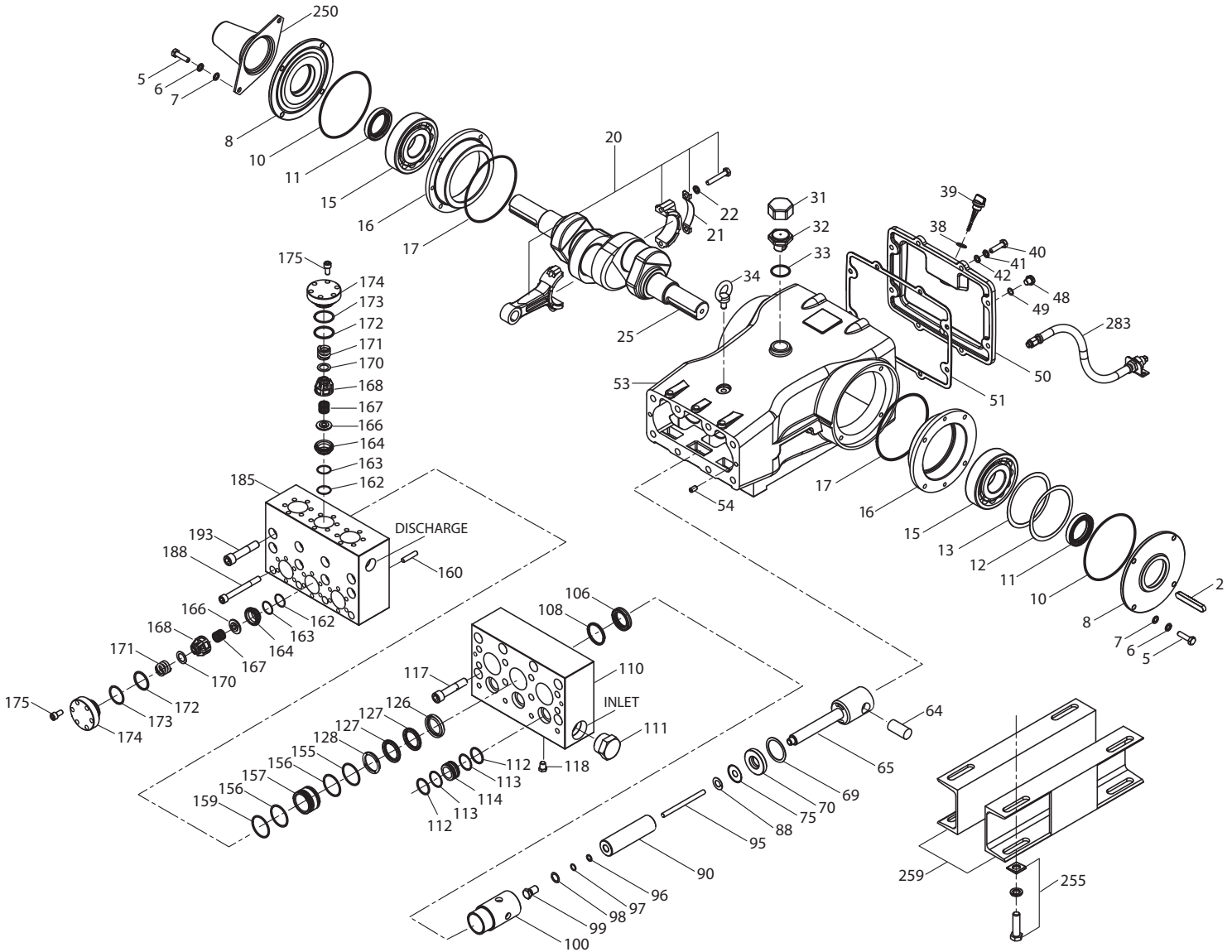

Models
Standard - 6831
Flushed - 6831K
April 2012

	6831	MATL	6831K	MATL		
299	910003	SS	—	—	Head, Complete, Block-Style	1
—	—	—	910004	SS	Head, Complete, Block-Style, Flushed	1
300	701647	NBR*	701647	NBR*	Kit, Seal (Incls: 97,106,112,113,127,155,156,159)	1
—	33708	FPM	33708	FPM	Kit, Seal (Incls: 97,106,112,113,127,155,156,159)	1
310	34017	NBR	34017	NBR	Kit, Valve (Incls: 162,163,164,166,167,168,170,172,173)	2
—	31955	FPM	31955	FPM	Kit, Valve (Incls: 162,163,164,166,167,168,170,172,173)	2
—	819010	F	819010	F	Assy, Crankcase, Cast Iron Conversion	1
370	—	—	990663	—	Assembly, Flushing, 5 gal., 115V, 1.1 Amp, 1/2" NPT	1
390	714500	SS	714500	SS	C.A.T. (Inlet pressure stabilizer for RO and boosted inlet applications)	1
391	714506	SS	714506	SS	Adapter (2 per C.A.T.) (See Data Sheet for complete selection)	2
392	701828	SS	701828	SS	Elbow Assy used with Adapter Assy 714506	1
—	6575	—	6575	—	Plunger Pump Service DVD	1
—	6105	—	6105	—	Oil, Twin Pack (Two 2.5 gal.) ISO-68 Hydraulic (Fill to specified crankcase capacity prior to start-up)	1
—	6119	—	6119	—	Lubricant, Antiseize (1 oz.)	1

Bold print part numbers are unique to a particular pump model. Italics are optional items. R Components comply with RoHS Directive.
*Review individual parts in each kit for material code identification.

See Tech Bulletin 002, 003, 024, 036, 074, 077, 083, 084, 095 and 105 for additional information.

C.A.T. highly recommended for pressurized inlet, R.O. and industrial applications.

MATERIAL CODES (Not Part of Part Number): ABS=ABS Plastic AL=Aluminum BBHS=Brass/High Strength CC=Ceramic CM=Chrome-Moly
D=Acetal F=Cast Iron FCM=Forged Chrome-moly FPM=Fluorocarbon NBR=Medium Nitrile (Buna-N) PTFE=Pure Polytetrafluoroethylene PVDF=Polyvinylidene Fluoride
S=304SS SS=316SS SSZZ=316SS/Zamak SFG=Special Blend FPM STG=Special Blend PTFE White STL=Steel
STCP=Steel/Chrome Plated STZP=Steel/Zinc Plated

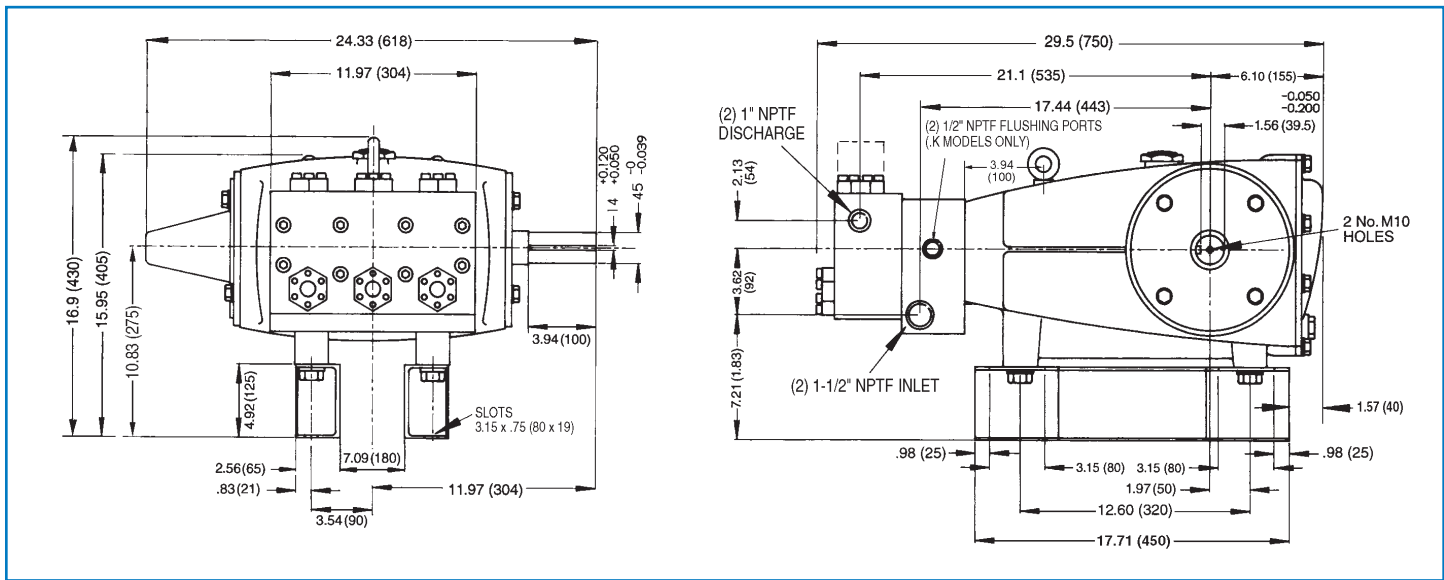

Models 6831, 6831K

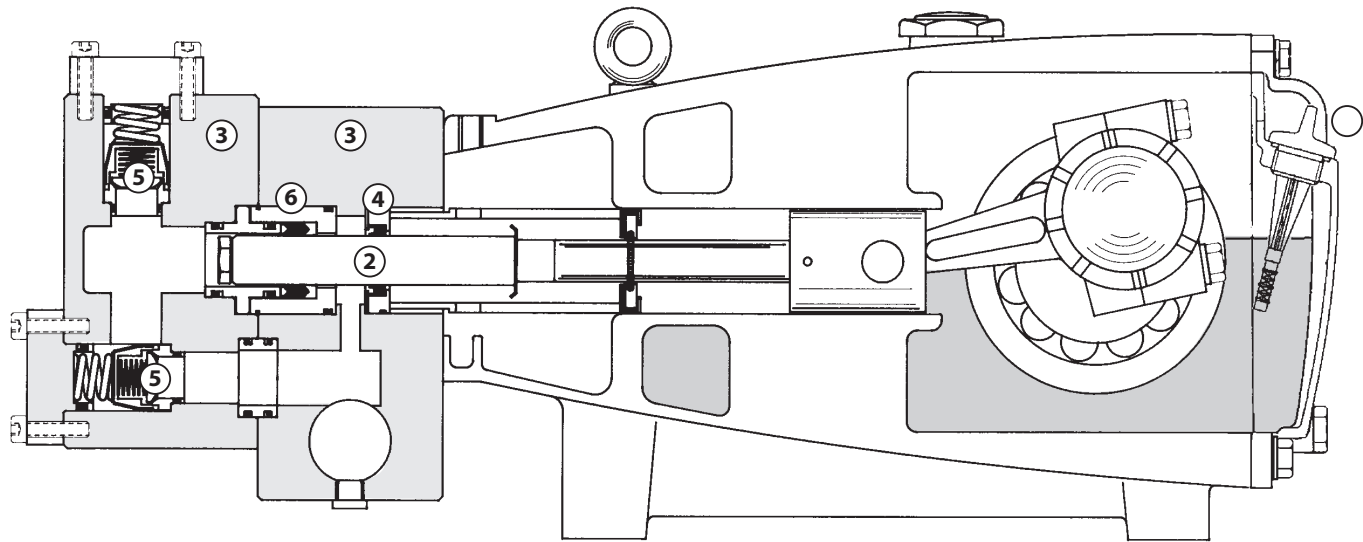

- 1 **Dipstick** offers top access for easy oil level check.
- 2 Special concentric, high density, polished, solid ceramic **plungers** provide a true wear surface and extended seal life.
- 3 **Manifolds** are 316 SS block-style for long-term, continuous-duty and corrosion resistance.
- 4 **Standard Models:** Lo-Pressure Seals and V-Packings are completely lubricated and cooled by the liquids being pumped.
Flushed Models: permits external flush for added cooling with high temperature liquids and lubrication with low lubricity liquids.
- 5 316 stainless steel **valves, seats and springs** provide corrosion-resistance, ultimate seating and extended life.
- 6 Specially formulated, Cat Pump exclusive, **V-Packings** offer unmatched performance and seal life.



PIJTTERSEN



The Pumps with Nine Lives

Pijtersen B.V.
Beneluxweg 33
9636 HV Zuidbroek
Tel.: +31(0)50-8200963

KvK 01013855
BIC RABONL2U
BTW NL002166811B01
IBAN NL24 RABO 0353 2970 97