

DATA SHEET

35 FRAME PLUNGER PUMPS



Model: 3570



PIJTTERSEN

E-mail : info@pijttersen.nl / info@catpumps.nl
Internet: www.pijttersen.nl / www.catpumps.nl

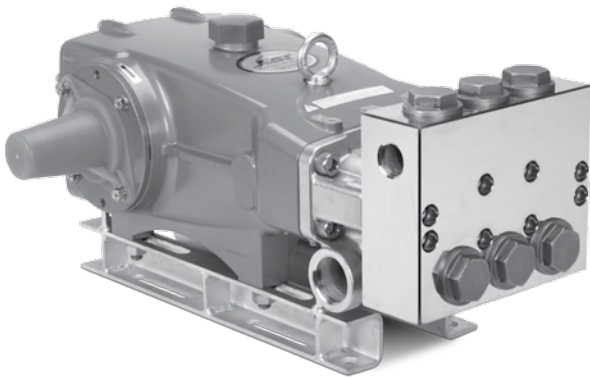

Model 3570 Shown
(Shaft protector included, mounting rails sold separately)

SPECIFICATIONS

	U.S. Measure	Metric Measure
Flow	30 gpm	114 lpm
Pressure Range	100-3000 psi	7-207 bar
Inlet Pressure	Flooded to 70 psi	Flooded to 4.9 bar
RPM	1080 rpm	1080 rpm
Bore	1.260"	32 mm
Stroke	1.890"	48 mm
Crankcase Capacity	4.2 qts	4 L
Maximum Liquid Temp.	140° F	60° C
Above 130°F call Cat Pumps for inlet conditions and elastomer recommendations.		
Inlets Ports (2)	1-1/2" NPT(F)	1-1/2" NPT(F)
Discharge Ports (2)	1" NPT(F)	1" NPT(F)
Pulley Mounting	Either Side	Either Side
Shaft Diameter	1.378"	35 mm
Weight	138.9 lbs	63 kg
Dimensions	23.94 x 18.11 x 9.72"	608 x 460 x 247 mm

FEATURES

- Triplex design delivers high efficiency and low pulsation.
- Durable dual V-Packings are lubricated and cooled by pumped liquid.
- Pre-set Lo-Pressure Seals provide secondary protection against external leaks and require no packing adjustment.
- Special high-density, polished, concentric plungers provide a true wear surface and extended seal life.
- Specially formulated Seals and V-Packings offer unmatched performance and extended life.
- Wet-end easily serviced without entering crankcase.
- Drive-end painted with two-coat electrostatic spray coating for superior corrosion resistance compared to anodizing.
- Two piece manifold design allows easier service compared to one piece design.

ELECTRIC HORSEPOWER REQUIREMENTS

FLOW		PRESSURE			RPM	DRIVE
		psi 2000	psi 2500	psi 3000		
U.S. gpm	lpm	bar 138	bar 175	bar 207		Consult Cat Pumps for Pump and Motor Pulley Sizes
30	114	41.1	51.4	61.6	1080	
20	76	27.4	34.2	41.1	720	

DETERMINING THE PUMP R.P.M.	$\frac{\text{Rated gpm}}{\text{Rated rpm}}$	=	$\frac{\text{"Desired" gpm}}{\text{"Desired" rpm}}$
DETERMINING THE REQUIRED H.P.	$\frac{\text{gpm} \times \text{psi}}{1460}$	=	$\frac{\text{Electric Brake}}{\text{H. P. Required}}$
DETERMINING MOTOR PULLEY SIZE	$\frac{\text{Motor Pulley O.D.}}{\text{Pump rpm}}$	=	$\frac{\text{Pump Pulley O.D.}}{\text{Motor rpm}}$

See complete Drive Packages [Incls: Pulleys, Belts, Hubs, Key] Tech Bulletin 003.
Refer to pump **Service Manual** for repair procedure and additional technical information.

PARTS LIST

ITEM	P/N	MATL	DESCRIPTION	QTY
2	34021	STL	Key (M10x8x70)	1
5	125753	S	Screw, HHC, Sems (M8x25)	8
8	44542	AL	Cover, Bearing	2
9	815279	FBR	Shim, Split, 2-Pc	3
10	12398	NBR	O-Ring, Bearing Cover - 70D	2
11	13296	NBR	Seal, Oil, Crankshaft	2
15	29326	STL	Bearing, Roller	2
20	121467	TNM	Rod, Connecting Assy (Incls: 21, 22, 23)	3
21	126749	STCP R	Washer, Locking (M10)	3
22	126593	STCP R	Washer, Flat (M10.5)	6
23	122045	STZP	Screw, HH (M10x55)	6
25	29325	FCM	Crankshaft, Dual End (M 48)	1
31	828710	PE	Protector, Oil Cap w/ Foam Gasket	1
32	43211	ABS	Cap, Oil Filler	1
33	14177	NBR	O-Ring, Oil Filler Cap - 70D	1
34	126743	STCP R	Bolt, Eye (M12x1.75) (For Lifting Pump Only)	1
37	92241	—	Gauge, Oil, Bubble w/Gasket	1
38	44428	NBR	Gasket, Flat, Oil Gauge - 80D	1
40	125753	S	Screw, HHC, Sems (M8x25)	8
48	25625	STCP	Plug, Drain (1/4"x19BSP)	1
49	23170	NBR	O-Ring, Drain Plug - 70D	1
50	45936	AL	Cover, Crankcase	1
51	16612	NBR	O-Ring, Crankcase - 70D	1
53	44487	AL	Crankcase Assy (Incls: 34, 54)	1
54	27488	S	Pins, Guide	2
56	27790	POP	Pan, Oil	1
59	92538	S	Screw, HHC, Sems (M6x16)	2
64	43864	CM	Pin, Crosshead	3
65	49166	SSHB	Rod, Plunger	3
69	126587	STCP R	Washer, Oil Seal	3
70	100488	NBRS	Seal, Oil, Crankcase	3
75	43865	S	Slinger, Barrier	3
88	45676	S	Washer, Keyhole (M16)	3
90	43957	CC	Plunger (M32X145)	3
95	† 89778	STCP R	Stud, Plunger Retainer (M10X135)	3
96	20189	PTFE	Back-up-Ring, Plunger Retainer	3
97	11345	NBR	O-Ring, Plunger Retainer - 70D	3
98	44085	SS	Gasket, Retainer	3
99	† 44084	BB	Retainer, Plunger (M10)	3
100	44119	PPG	Retainer, Seal	3
101	44106	—	Wick, Long Tab	3
104	43875	NBR	O-Ring, Adapter - 70D	3
105	49741	BB	Adapter	3
106	43959	NBR	Seal, LPS w/SS-Spg	3
107	43962	S	Washer, LPS	3
110	49464	BBCP R	Manifold, Inlet	1
112	11379	NBR	O-Ring, Inlet Manifold	3
117	44585	S	Screw, HSH (M14 x 40)	4
122	49744	BB	Spacer, V-Packing	3
123	12391	NBR	O-Ring, Spacer - 70D	3
124	49742	BB	Cylinder, V-Packing	3
126	43963	BB	Adapter, Female	3
127	43964	SNG	V-Packing	6
128	43965	BB	Adapter, Male	3
141	49743	SS	Spring, Coil	3
155	48860	NBR	O-Ring, V-Packing Cylinder - 90D	3
156	48362	D	Back-up-Ring, V-Packing Cylinder	3
162	48363	D	Back-up-Ring, Valve Seat	6
163	26142	NBR	O-Ring, Valve Seat - 80D	6
164	133052	S	Seat, Valve	6
166	43932	S	Valve	6
167	133053	S	Spring	6
168	44728	PVDF	Retainer, Spring	6
170	44729	SS	Washer, Spring	6
171	44644	SS	Spring, Coil	6
172	89827	NBR	O-Ring, Valve Plug - 90D	6
173	48364	D	Back-up-Ring, Valve Plug	6
174	44643	NAB	Plug, Valve	6
185	133049	BBCP	Manifold, Discharge	1
188	89981	S	Screw, HSH (M12 x 70)	8
250	44516	NY	Protector, Shaft w/2 Screws, Lockwashers and Washers (Included with pump)	1

EXPLODED VIEW

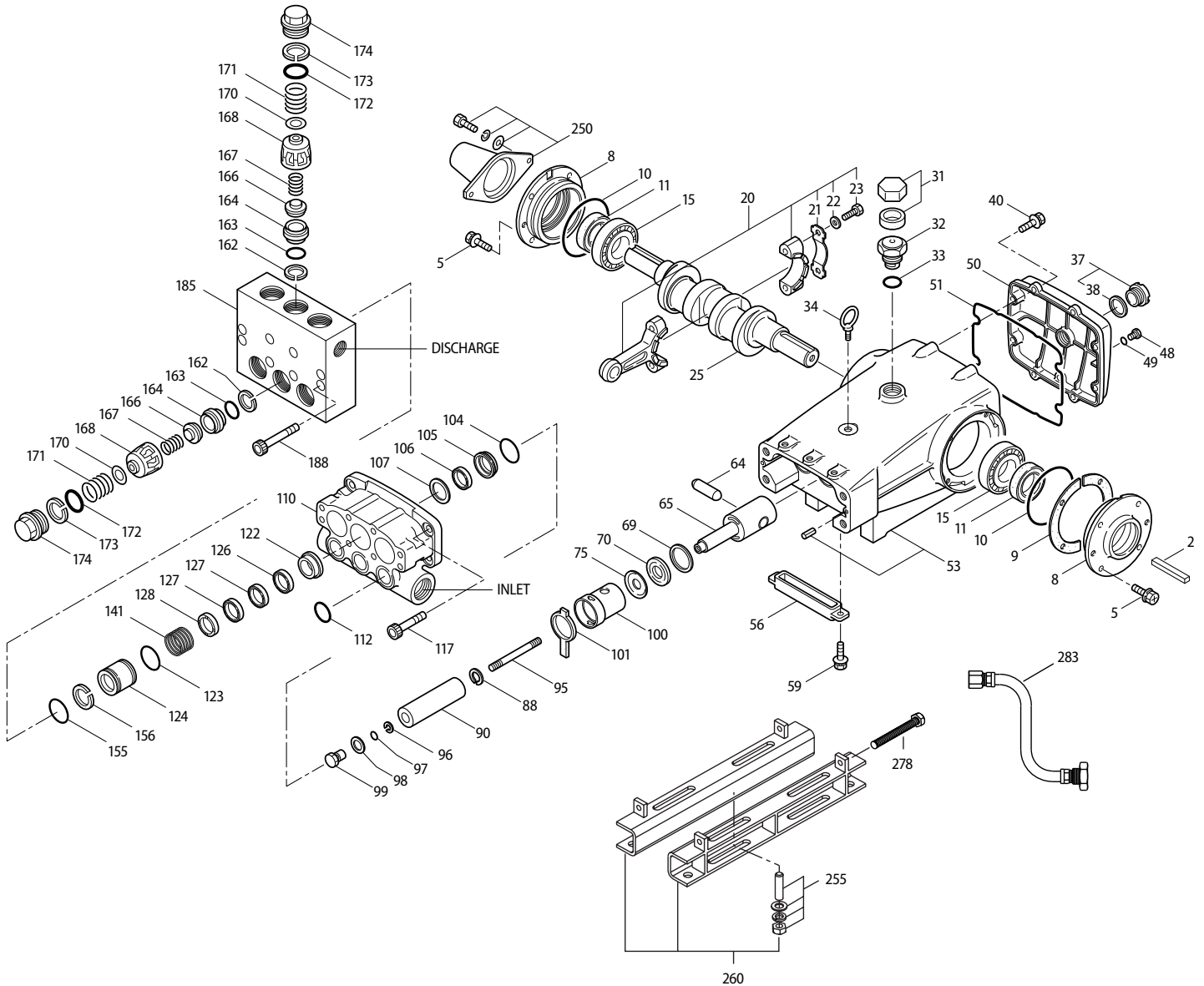

Model 3570
April 2015

ITEM	P/N	MATL	DESCRIPTION	QTY
255	34018	STZPR	Kit, Direct Mount	1
260	92674	STZPR	Mount, Rail Assembly (Includes: 34018)	1
278	80540	ZP	Screw, HH (M12 x 100) (Rail Adjusting Screw)	1
279	30278	STZP	Oiler (1 oz.)	3
283	34314	—	Kit, Oil Drain (3/8" x 48") (See individual data sheet)	1
	34334	—	Kit, Oil Drain (3/8" x 24") (See individual data sheet)	1
	76334	—	Kit, Oil Level Indicator (3/8" x 24") (See individual data sheet)	1
290	6124	—	Gasket, Liquid (3 oz.)	1
299	818610	BBCPR	Head, Complete	1
300	76782	NBR*	Kit, Seal (Includes: 97, 104, 106, 112, 123, 127, 155, 156)	1
310	76794	NBR	Kit, Valve (Includes: 162, 163, 164, 166, 167, 168, 170, 172, 173)	2
	6100	—	Oil, Case (12 Bottles) ISO 68 Hydraulic (Fill to specified crankcase capacity prior to start-up)	1

Italics are optional items. * Review material codes for individual items (SNG generally may be used as alternate). R Components comply with RoHS Directive.

[] Date of latest production change View Tech Bulletins 003, 024, 035, 036, 043, 074 and 083 for additional information. † Production parts different from service parts.

MATERIAL CODES (Not Part of Part Number): ABS=ABS Plastic AL=Aluminum BB=Brass BBCP=Brass/Chrome Plated CC=Ceramic CM=Chrome-Moly D=Acetal

FBR=Fiber FCM=Forged Chrome-Moly NAB=Nickel Aluminum Bronze NBR=Medium Nitrile (Buna-N) NBR5=Buna, Silicone Free

NY=Nylon PE=Polyethylene POP=Polypropylene PPG=Glass Filled Polypropylene PTFE=Pure Polytetrafluoroethylene PVDF=Polyvinylidene Fluoride S=304SS SS=316SS

SNG=Special Blend (Buna) SSHB=316SS/High Strength STCP=Steel/Chrome Plated STL=Steel STZP=Steel/Zinc Plated TNM=Special High Strength ZP=Zinc Plated

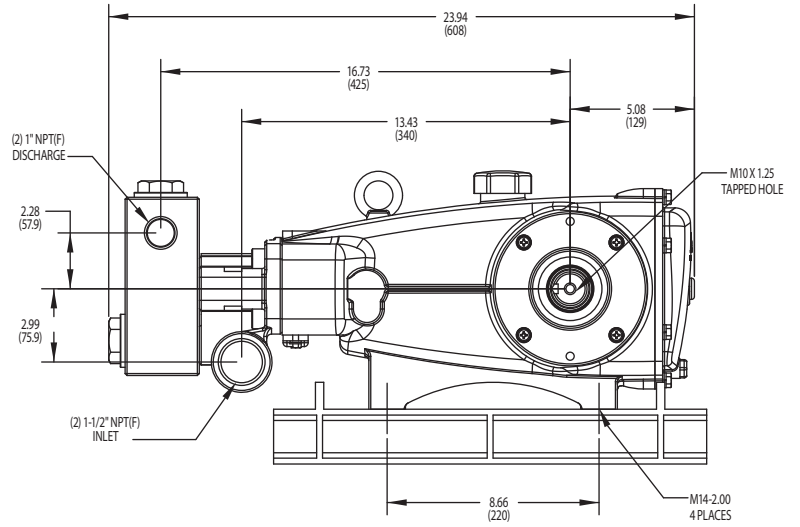
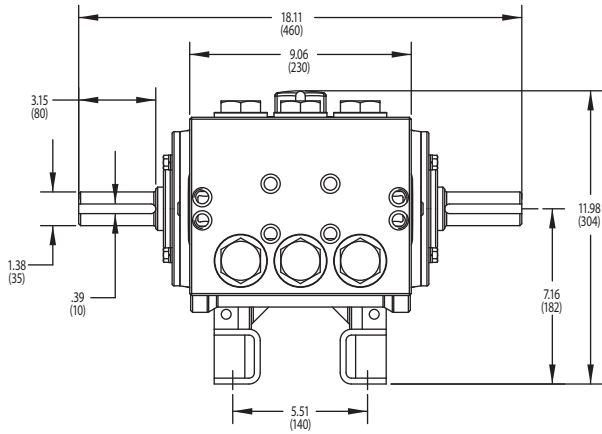

PIJTTERSEN



Pijttersen B.V.
 Beneluxweg 33
 9636 HV Zuidbroek
 Tel.: +31(0)50-8200963

KvK 01013855
 BIC RABONL2U
 BTW NL002166811B01
 IBAN NL24 RABO 0353 2970 97