

(Rails and shaft protector sold separately)

15 Frame Plunger Pump

**Standard Brass
Model**

1560

FEATURES

- | Triplex design offers high efficiency and low pulsation.
- | Durable V-Packings are lubricated and cooled by the liquid being pumped.
- | Pre-set Lo-Pressure Seals provide secondary protection against external leaks and require no packing adjustment.
- | Optional STHT and FPM elastomers for compatibility with many liquids and temperatures up to 200°F
- | Stacked valve design for ease in servicing.
- | Special high-density, polished, concentric plungers provide a true wear surface and extended seal life.

SPECIFICATIONS

	U.S. Measure	Metric Measure
Flow	8.0 gpm	(30 lpm)
Pressure Range.....	100 to 4000 psi	(7 to 275 bar)
RPM	1140 rpm	(1140 rpm)
Inlet Pressure Range.....	Flooded to 70 psi	(Flooded to 4.9 bar)
Bore	0.787"	(20 mm)
Stroke.....	1.181"	(30 mm)
Crankcase Capacity.....	42 oz.	(1.26 l)
Maximum Liquid Temperature	140°F	(60°C)
Above 130°F call Cat Pumps for inlet conditions and elastomer recommendations.		
Inlet Ports (2).....	3/4" NPTF	(3/4" NPTF)
Discharge Ports (2).....	1/2" NPTF	(1/2" NPTF)
Pulsator Port (1).....	1/8" NPTF	(1/8" NPTF)
Pulley Mounting	Either Side	(Either Side)
Shaft Diameter	1.181"	(30 mm)
Weight	59.9 lbs.	(27.2 kg)
Dimensions.....	16.93 x 12.99 x 6.44" (430 x 330 x 163.5 mm)	

⚠ CAUTIONS AND WARNINGS

All High Pressure Systems require a primary pressure regulating device (i.e. regulator, unloader) and a secondary pressure relief device (i.e. pop-off valve, relief valve). Failure to install such relief devices could result in personal injury or damage to pump or property. CAT PUMPS does not assume any liability or responsibility for the operation of a customer's high pressure system.

Read all CAUTIONS and WARNINGS before commencing service or operation of any high pressure system. The CAUTIONS and WARNINGS are included in each service manual and with each Accessory Data sheet. CAUTIONS and WARNINGS can also be viewed online at www.catpumps.com/cautions-warnings or can be requested directly from CAT PUMPS.

WARRANTY

View the Limited Warranty on-line at www.catpumps.com/warranty.

ELECTRIC HORSEPOWER REQUIREMENTS

FLOW		PRESSURE				RPM	DRIVE
		psi 2500	psi 3000	psi 3500	psi 4000		
U.S. gpm	l/m	bar 175	bar 210	bar 245	bar 275		Consult Cat Pumps for Pump and Motor Pulley Sizes
8	30	13.7	16.4	19.2	21.9	1140	
7	27	12.0	14.4	16.8	19.2	998	
6	23	10.3	12.3	14.4	16.4	855	

DETERMINING THE PUMP R.P.M.	<u>Rated gpm</u>	=	<u>"Desired" gpm</u>
	Rated rpm	=	"Desired" rpm
DETERMINING THE REQUIRED H.P.	<u>gpm x psi</u>	=	Electric Brake
	1460	=	H. P. Required
DETERMINING MOTOR PULLEY SIZE	<u>Motor Pulley O.D.</u>	=	<u>Pump Pulley O.D.</u>
	Pump rpm	=	Motor rpm

See complete Drive Packages [Incls: Pulleys, Belts, Hubs, Key] Tech Bulletin 003. Refer to pump **Service Manual** for repair procedure and additional technical information.

PARTS LIST

ITEM	P/N	MATL	DESCRIPTION	QTY
2	990036	STL	Key (M8x7x40) Use w/30059 and 990012	1
—	30067	STL	Key (M8x7.5x25) Use w/30059 "H" Hub	1
5	125824	STCP R	Screw, HHC, Sems (M6x16)	8
8	43496	AL	Cover, Bearing	2
9	815281	FBR	Shim, Split, 2-Pc	6
10	11340	NBR	O-Ring, Bearing Cover - 70D	2
11	43495	NBR	Seal, Oil, Crankshaft - 70D	2
12	814800	S	Shim, Split, 2-Pc	2
15	39060	STL	Bearing, Roller	2
20	126805	BZ	Rod, Connecting Assembly	3
25	43494	FCM	Crankshaft, Dual-End (M30)	1
31	828710	PE	Protector, Oil Cap w/Foam Gasket	1
32	43211	ABS	Cap, Oil Filler	1
33	14177	NBR	O-Ring, Filler Cap - 70D	1
37	92241	—	Gauge, Oil, Bubble w/Gasket - 80D	1
38	44428	NBR	Gasket, Flat, Oil Gauge - 80D	1
40	126541	STCP R	Screw, HHC, Sems (M6x20)	4
48	25625	STCP	Plug, Drain (1/4"x19BSP)	1
49	23170	NBR	O-Ring, Drain Plug - 70D	1
50	43491	AL	Cover, Rear	1
51	44834	NBR	O-Ring, Rear Cover - 70D	1
53	115471	AL	Crankcase w/Guide Pins	1
56	44664	POP	Pan, Oil	1
64	43507	CM	Pin, Crosshead	3
65	49223	SBZ	Rod, Plunger	3
69	126592	STCP R	Washer, Oil Seal	3
70	43500	NBR	Seal, Oil Crankcase - 80D	3
75	43506	S	Slinger, Barrier	3
88	45675	S	Washer, Keyhole	3
89	43505	BB	Spacer	3
90	43300	CC	Plunger, Ceramic (M20x77)	3
96	43235	PTFE	Back-up-Ring, Plunger Retainer	3
97	17399	NBR	O-Ring, Plunger Retainer - 80D	3
	14160	FPM	O-Ring, Plunger Retainer - 80D	3
98	45891	CU	Gasket, Plunger Retainer	3
99	104360	S	Retainer w/Stud, Plunger	3
100	855001	POP	Retainer, Seal, 2-Pc	3
101	43508	—	Wick	3
106	† 44071	NBR	Seal, LPS w/SS-Spg	3
	44381	FPM	Seal, LPS w/S-Spg	3
	76071	ST2	Seal, LPS w/SS-Spg	3
110	49229	FBB	Manifold, Inlet	1
112	14179	NBR	O-Ring, Inlet Manifold - 70D	3
	15855	FPM	O-Ring, Inlet Manifold - 70D	3
117	126515	STCP R	Screw, HSH (M10x55)	4
126	49231	BB	Adapter, Female	3
127	† 44607	STG	V-Packing	9
155	14176	NBR	O-Ring, Spacer, V/P - 70D	6
	13260	FPM	O-Ring, Spacer, V/P - 70D	6
156	49232	PTFE	Back-up-Ring, Spacer, V/P	6
157	49230	BB	Spacer, V/P	3
160	49238	NBR	O-Ring, Seat, Inlet - 90D	3
	129593	FPM	O-Ring, Seat, Inlet - 70D	3
161	49237	S	Seat, Inlet	3
162	49235	PTFE	Back-up-Ring, Seat	3
163	49236	NBR	O-Ring, Seat, Discharge - 70D	3
	129594	FPM	O-Ring, Seat, Discharge - 70D	3
164	49234	S	Seat, Discharge	3
165	49198	PVDF	Retainer, Spring, Inlet	3
166	48793	SS	Valve	6
167	43751	S	Spring	6
168	49199	PVDF	Retainer, Spring, Discharge	3
172	14176	NBR	O-Ring, Valve Plug - 70D	3
	13260	FPM	O-Ring, Valve Plug - 70D	3
173	49232	PTFE	Back-up-Ring, Valve Plug	3
174	49239	BB	Plug, Valve	3
177	126783	STCP R	Screw, HSH (M12x25)	8
178	49227	BB	Cover, Valve	1
183	49462	BB	Plug, Pulsator Port (1/8" NPTM)	1
185	49197	FBB	Manifold, Discharge	1
188	126519	STCP R	Screw, HSH (M12x70)	6
250	30764	NY	Protector, Shaft w/2 Screws	1
255	30264	STZP	Mount, Direct	1
260	30613	STZP R	Mount Rail Assy	1
269	30206	F	Pulley (10") [See Drive Packages, Tech Bulletin 003]	1
270	30059	STL	Hub, "H", M30 (Keyway M8) [See Drive Packages, Tech Bulletin 003]	1

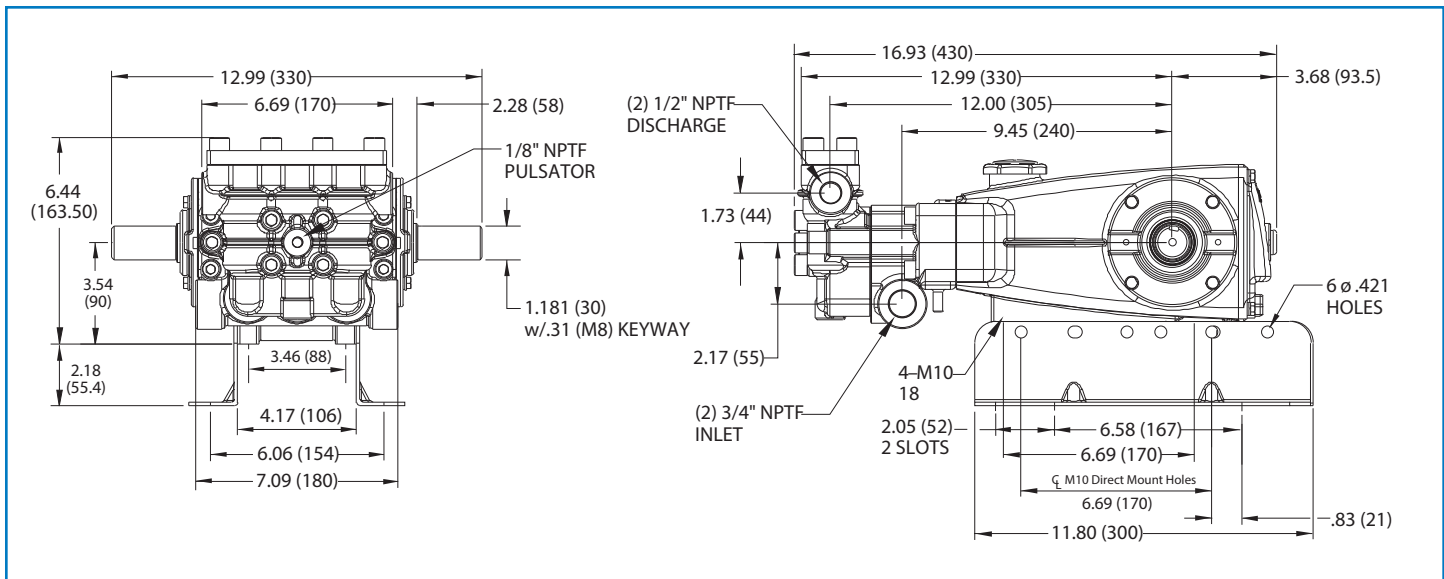

Model 1560

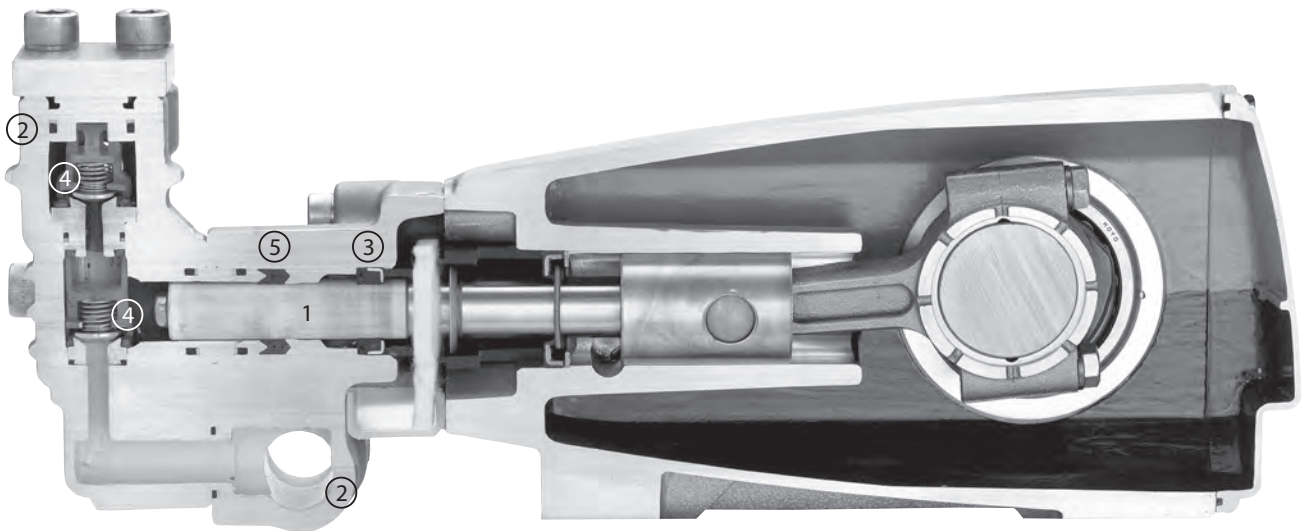

- 1 Special concentric, high-density, polished, solid ceramic **plungers** provide a true wear surface and extended seal life.
- 2 **Manifolds** are a high strength forged brass for long-term, continuous duty.
- 3 100% wet **seal** design adds to service life by allowing pumped liquids to cool and lubricate on both sides of seals.
- 4 Stacked stainless steel **valve assemblies** include valves, seats and springs to provide corrosion-resistance, ultimate seating and extended life.
- 5 Specially formulated, Cat Pumps exclusive, **V-Packings** offer unmatched performance and seal life.
- 6 Special **pulsator assembly port** to switch from high pressure to jetting (not shown).



PIJTTERSEN

Pijtersen B.V.
 Stavangerweg 14A
 9723 JC GRONINGEN
 THE NETHERLANDS

Tel.: +31 (0)50-8200963

E-mail : info@pijtersen.nl / info@catpumps.nl

Internet: www.pijtersen.nl / www.catpumps.nl



The Pumps with Nine Lives