

DATA SHEET

15 FRAME PLUNGER PUMPS



Brass
1540E

Flushed
1540EC

Stainless Steel
1541

Stainless Steel
Flushed
1541C

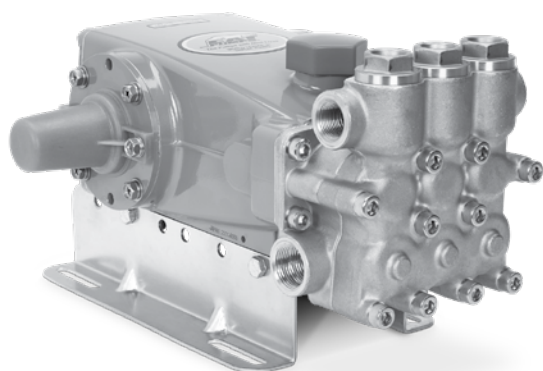

Model 1540E Shown
(Mounting rails sold separately)

FEATURES

- Triplex design offers high efficiency and low pulsation.
- Special high-density, polished, concentric plungers provide a true wear surface and extended seal life.
- Pre-set low-pressure seals provide secondary protection against external leaks and require no packing adjustment.
- Models 1540EC and 1541C offers external flush for high-temperature or low-lubricity fluids.
- Belt-driven option provides precision flow setting.
- Compact direct-drive with bell housing and flexible coupler assembly. NEMA or IEC electric motor or SAE hydraulic options available.
- Standard pumps are fitted with NBR Seals. Optional seals are available for high temperatures or chemical compatibility.

SPECIFICATIONS

	U.S. Measure	Metric Measure
Flow	19.3 gpm	73 lpm
Pressure Range	100 – 1200 psi	6.9 – 83 bar
Pump RPM*	1180 rpm	1180 rpm
Inlet Pressure Range	Flooded to 70 psi	Flooded to 4.8 bar
Max. Liquid Temp. (NBR)	140° F	60° C
Alternate seals available for higher temperatures up to 180° F		
Bore	1.181"	30 mm
Stroke	1.181"	30 mm
Crankcase Capacity	42 oz.	1.26 l
Inlet Ports (2)	1" NPT(F)	1" NPT(F)
Flush Ports (2) (1540EC, 1541C)	1/8" NPT(F)	1/8" NPT(F)
Discharge Ports (2)	3/4" NPT(F)	3/4" NPT(F)
Pulley Mounting	Either Side	Either Side
Shaft Diameter	1.181"	30 mm
Weight	42.6 lbs.	21 kg
Dimensions	14.57 x 12.99 x 6.42"	370 x 330 x 163 mm

*Pump minimum is 100 RPM.

ALTERNATIVE SEAL CONFIGURATION

MATERIAL	SUFFIX CODE	MAXIMUM TEMPERATURE
NBR	—	140° F (60° C)
FPM	.0110	180° F (82° C)

See **Tech Bulletin 002** for inlet conditions and RPM at high-temperature.

DETERMINING THE PUMP R.P.M.	$\frac{\text{Rated gpm}}{\text{Rated rpm}}$	=	$\frac{\text{"Desired" gpm}}{\text{"Desired" rpm}}$
DETERMINING THE REQUIRED H.P.	$\frac{\text{HP (Electric Brake)}}{1460}$	=	$\frac{\text{gpm} \times \text{psi}}{1460}$
DETERMINING MOTOR PULLEY SIZE	$\frac{\text{Motor Pulley O.D.}}{\text{Pump rpm}}$	=	$\frac{\text{Pump Pulley O.D.}}{\text{Motor rpm}}$

Refer to pump **Service Manual** for repair procedure and additional technical information.



PIJTTERSEN

E-mail : info@pijtersen.nl / info@catpumps.nl
 Internet : www.pijtersen.nl / www.catpumps.nl

PARTS LIST

ITEM	PART NUMBER		PART NUMBER		DESCRIPTION	QTY
	1540E	MATL	1541	MATL		
5	49651	S	49651	S	Screw, HHC Sems (M8 x 20) (See Tech Bulletin 074, 128)	8
8	134805	ALE	134805	ALE	Cover, Bearing (See Tech Bulletin 118, 128)	2
9	855043	FBR	855043	FBR	Shim, Split 2-Piece (See Tech Bulletin 128)	0-2
10	11340	NBR	11340	NBR	O-Ring, Bearing Cover – 70D	2
11	43495	NBR	43495	NBR	Seal, Oil, Crankshaft – 70D	2
12	855044	S	855044	S	Shim, Split, 2-Piece (See Tech Bulletin 128)	0-2
15	39060	STL	39060	STL	Bearing, Roller	2
20	48600	TNM	48600	TNM	Rod, Connecting Assembly (See Tech Bulletin 074)	3
25	43494	FCM	43494	FCM	Crankshaft, Dual-End (M30)	1
32	43211	ABS	43211	ABS	Cap, Oil Filler	1
33	14177	NBR	14177	NBR	O-Ring, Filler Cap – 70D	1
37	92241	PC	92241	PC	Gauge, Oil, Bubble with Gasket – 80D (See Tech Bulletin 074)	1
38	44428	NBR	44428	NBR	Gasket, Flat, Oil Gauge – 80D	1
40	92542	S	92542	S	Screw, HHC Sems (M6 x 20) (See Tech Bulletin 074)	4
48	25625	STCP	25625	STCP	Plug, Drain (1/4" x 19BSP)	1
49	23170	NBR	23170	NBR	O-Ring, Drain Plug – 70D	1
50	133576	ALE	133576	ALE	Cover, Rear (See Tech Bulletin 118)	1
51	44834	NBR	44834	NBR	O-Ring, Rear Cover – 70D	1
53	134858	ALE	134858	ALE	Crankcase (Includes Guide Pins) (See Tech Bulletin 118, 128)	1
54	27488	S	27488	S	Pin, Guide	2
64	43507	CM	43507	CM	Pin, Crosshead	3
65	48933	SHS	49611	SS	Rod, Plunger (Center)	1
66	48931	SHS	49609	SS	Rod, Plunger (Outside)	2
69	126596	STCP R	126596	STCP R	Washer, Oil Seal	3
70	43500	NBR	43500	NBR	Seal, Oil Crankcase – 80D	3
88	48937	S	48937	S	Washer, Flat	3
90	48938	CC	48938	CC	Plunger, Ceramic (M30 x 65)	3
98	46730	NBR	46730	NBR	Washer, Seal – 90D	3
99	† 48201	SS	48201	SS	Retainer, Plunger (See Tech Bulletin 074)	3
100	48936	PVDF	48936	PVDF	Retainer, Seal	3
106	49067	NBR	—	—	Seal, LPS with S-Spring	3
	—	—	49616	NBR	Seal, LPS with SS-Spring	3
	702939	ST4	—	—	Seal, with NiH-Spring	3
110	48940	FBB	49614	SS	Manifold, Inlet	1
	49853	FBB	134147	SS	Manifold, Inlet Flushed [1/8" NPT(F) Port]	1
112	123903	NBR	123903	NBR	O-Ring, Inlet Manifold – 90D	3
117	49044	S	49044	S	Screw, HSH (M10 x 25) (See Tech Bulletin 074)	4
125	48944	SNG	—	—	Seal, HPS with Stainless Steel	3
	49619	STG	49619	STG	Seal, Assembly 2 piece with SS Support	3
155	123903	NBR	123903	NBR	O-Ring, Spacer – 90D	6
157	48946	BB	49621	SS	Spacer, HPS	3
163	26143	NBR	26143	NBR	O-Ring, Seat – 80D	6
164	48951	S	49626	SS	Seat	6
166	48686	SS	48686	SS	Valve	6
167	48687	SS	48687	SS	Spring	6
168	48994	PVDF	48994	PVDF	Retainer, Spring	6
170	123764	S	49627	SS	Washer, Spring Retainer	6
172	17629	NBR	17629	NBR	O-Ring, Valve Plug – 80D	3
174	48952	FBB	49628	SSZZ	Plug, Valve (See Tech Bulletin 074) (See Tech Bulletin 074)	3
185	48948	FBB	49623	SS	Manifold, Discharge	1
188	87952	S	87952	S	Screw, HSH (M10 x 55) (See Tech Bulletin 074)	10
250	855046	NY	—	—	Protector, Shaft with 2 Screws PN 126544 (See Tech Bulletin 128)	1
	—	—	855047	NY	Protector, Shaft with 2 Screws PN 125753 (See Tech Bulletin 128)	1

Bold part numbers are unique to a particular pump model.

Italics are optional items. † Production parts are different than replacement parts.

R Components comply with RoHS Directive. For additional technical information see www.catpumps.com/literature/tech-bulletins.

MATERIAL CODES (Not Part of Part Number): ABS=ABS Plastic ALE=Aluminum Epoxy BB=Brass CC=Ceramic CM=Chrome-moly F=Cast Iron FBB=Forged Brass FBR=Fiber FCM=Forged Chrome-moly FPM=Fluorocarbon NBR=Medium Nitrile (Buna-N) NY=Nylon PC=Poly Carbonate PE=Polyethylene PVDF=Polyvinylidene Fluoride S=304SS SHS=304SS/High Strength SS=316SS SSZZ=316SS/Zamak SNG=Special Blend (Buna) STG=Special Blend PTFE White ST4=Special PTFE 4 STCP=Steel/Chrome Plated STL=Steel STZP=Steel/Zinc Plated TNM=Special High Strength

EXPLODED VIEW

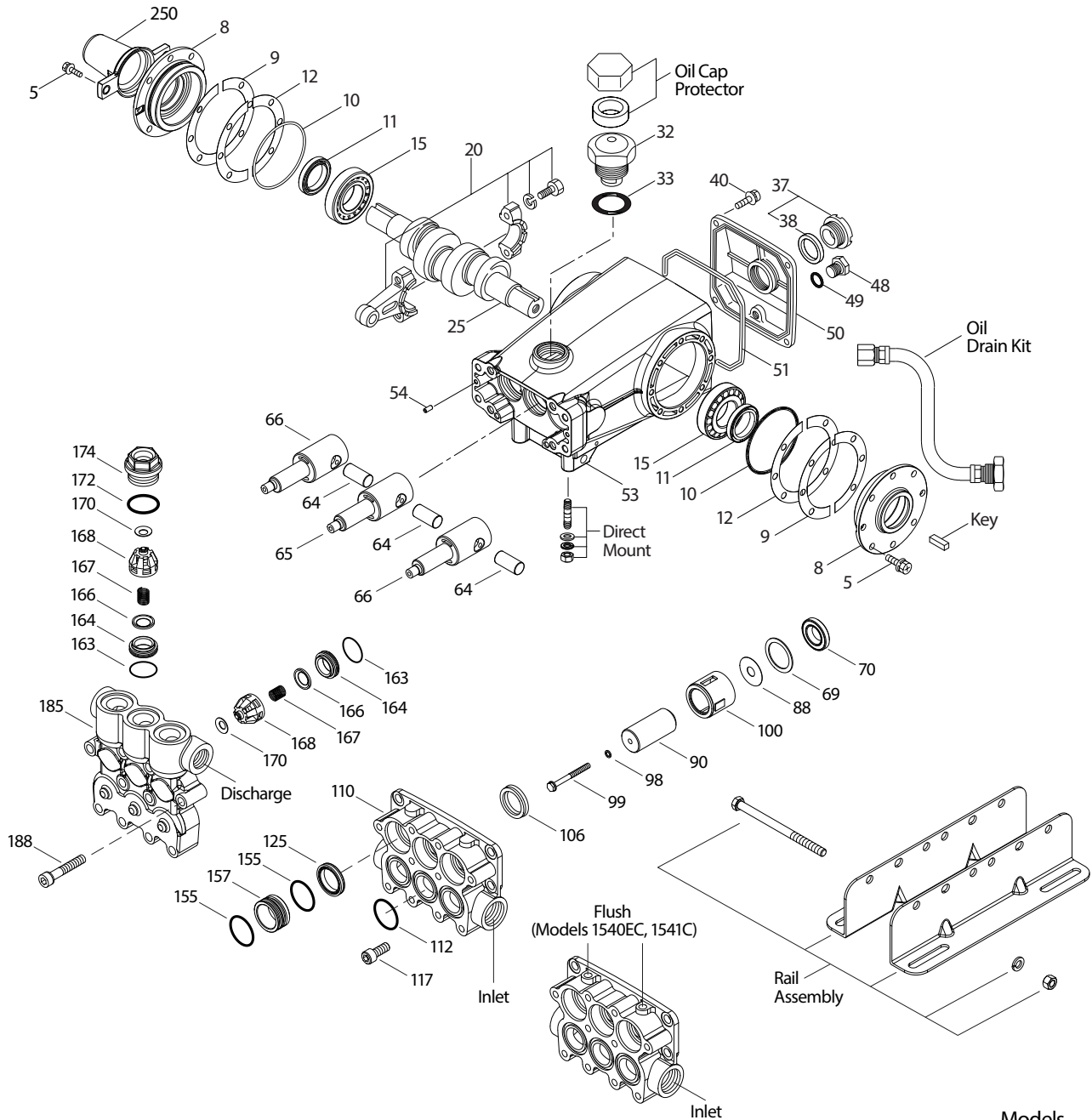

Models
 Brass – 1540E
 Flushed – 1540EC
 Stainless Steel – 1541
 Stainless Steel Flushed – 1541C
 October 2020

OPTIONAL PARTS AND ACCESSORIES

PART	DESCRIPTION	QTY
30067	Key, M8 x 7.5 x 25	1
990036	Key, M8 x 7 x 40	1
30613	Assembly, Rail (5.72" See Dimensional Drawing)	1
76513	Assembly, Rail (6.22" See Dimensional Drawing)	1
990550	Assembly, Rail, Diesel (5.72" See Dimensional Drawing)	1
30264	Mount, Direct	1
828710	Protector, Oil Cap	1
34334	Kit, Oil Drain	1
30206	Pulley, 10", 2 Groove H	1
30059	Hub, H, 30mm	1
990012	Hub, B, 30mm	1

SERVICE PARTS

PART	DESCRIPTION	QTY
31770	Kit, Seal (Models 1540E, 1540EC)	1
31430	Kit, Seal (Models 1541, 1541C)	1
31775	Kit, Valve (Models 1540E, 1540EC)	2
31450	Kit, Valve (Models 1541, 1541C)	2
6107	Oil, Bottle (21 oz.)	1-2
6124	Gasket, Liquid (3 oz.)	1
6119	Lubricant, Anti-seize (2 oz.) (Model 1541, 1541C)	1
701931	Sealant, Silicone (See Tech Bulletin 100) (Model 1540E)	1
816863	Head, Complete with NBR Seals and O-Rings (Model 1540E)	1
818443	Head, Complete with NBR Seals and O-Rings (Model 1541)	1

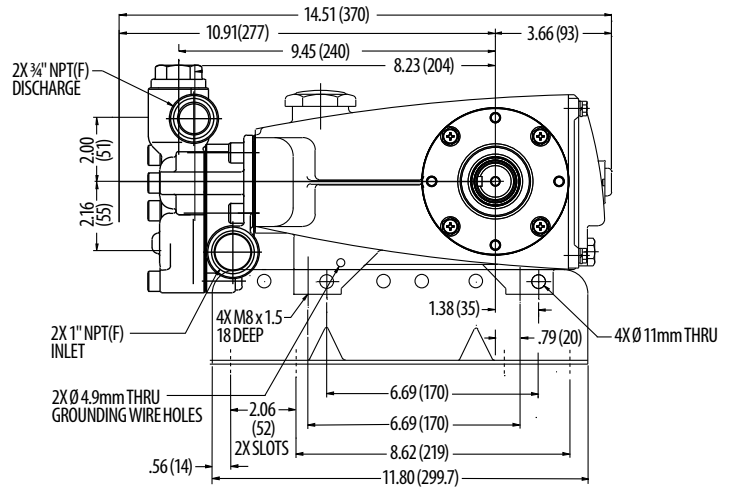
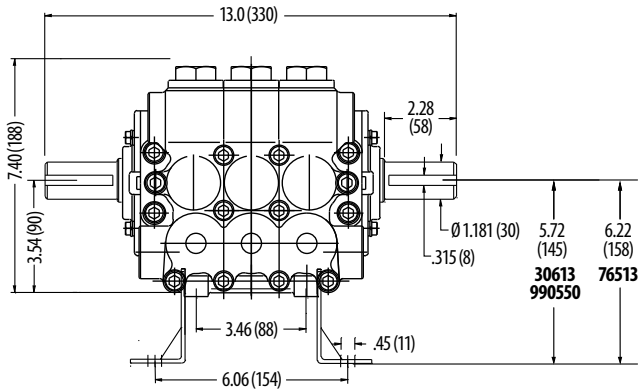

SEAL KITS One (1) seal kit required per pump

PUMP MODELS	NBR (STD)	FPM (0.0110)
1540E,1540EC,	31770	76430
1541, 1541C	31430*	76430

ITEM (Included in Seal Kits)	DESCRIPTION		QTY	
98	46730	48394	O-Ring, Plunger Retainer	3
106	49067		Seal, LPS with S-Spring (Models 1540E, 1540EC)	3
	702939	702939	Seal, LPS with NIH-Spring (Models 1540E, 1540EC)	3
	49616		Seal, LPS with SS-Spring (Models 1541, 1541C)	3
112	123903	76903	O-Ring, Inlet Manifold	3
125	48944		Seal, HPS (Models 1540E, 1540EC)	3
	49619	49619	Assembly, Seal 2-Piece with SS Support (Models 1541, 1541C)	3
155	123903	76903	O-Ring, Spacer	6

* Review material codes for individual items (STG maybe used as an alternative)

VALVE KITS Two (2) valve kit required per pump

PUMP MODELS	NBR (STD)	FPM (0.0110)
1540E,1540EC,	31775	76775
1541, 1541C	31450	76450

ITEM (Included in Valve Kits)	DESCRIPTION		QTY	
163	26143	14331	O-Ring, Valve Seat	3
164	48951	48951	Seat (Models 1540E, 1540EC)	3
	49626	49626	Seat (Models 1541,1541C)	3
166	48686	48686	Valve	3
167	48687	48687	Spring	3
168	48994	48994	Retainer, Spring	3
170	123764	123764	Washer, Spring Retainer (Models 1540E, 1540EC)	3
	49627	49627	Washer, Spring Retainer (Models 1541, 1541C)	3
172	17629	14183	O-Ring, Valve Plug	3

CAUTIONS AND WARNINGS

All high-pressure systems require a primary pressure regulating device (i.e. regulator, unloader) and a secondary pressure relief device (i.e. pop-off valve, relief valve). Failure to install such relief devices could result in personal injury or damage to pump or property. Cat Pumps does not assume any liability or responsibility for the operation of a customer's high-pressure system.

Read all CAUTIONS and WARNINGS before commencing service or operation of any high-pressure system. The CAUTIONS and WARNINGS are included in each Service Manual and with each Accessory Data sheet. CAUTIONS and WARNINGS can also be viewed online at www.catpumps.com/dynamic-literature/cautions-and-warnings or can be requested directly from Cat Pumps.



PIJTTERSEN

Pijtersen B.V.
Beneluxweg 33
9636 HV Zuidbroek
Tel.: +31 (0)50-8200963

KvK 01013855
BIC RABONL2U
BTW NL002166811B01
IBAN NL24 RABO 0353 2970 97

www.pijtersen.nl - info@pijtersen.nl | www.catpumps.nl - info@catpumps.nl

