

ECO.36+

Kernboormachine

EUROBOOR

FOR PROFESSIONALS BY PROFESSIONALS

Technische data

	Metrisch	Imperisch
Kernboren	Ø 12 - 36 mm	1/2" - 1 7/16"
Spiraalboren (Weldon)	Ø 1 - 14 mm	1/16" - 9/16"
Verzinken	Ø 10 - 40 mm	3/8" - 1 9/16"
Hoekboren	0°: 50 mm	2"
	90°: 53 mm	2 1/16"
	45°: 60 mm	2 3/8"
Lengte	310 mm	12 3/16"
Breedte	135 mm	5 5/16"
Hoogte	165 mm	6 1/2"
Slag	40 mm	1 9/16"
Gewicht*	10,3 kg	22,7 lbs
Magneet (l x b x h)	160 x 80 x 37 mm	6 5/16" x 3 1/8" x 1 7/16"
Magnetische kracht	1.200 kg	2.645 lbs
Motor vermogen	1.050 W	9,5 A
Totaal vermogen	1.100 W	10 A
Toerental (onbelast)		700 tpm
Toerental (belast 1.050 W, 9,5 A)		400 tpm
Opname (Weldon)	19,05 mm	3/4"
Krachtvoorziening		110 - 120 V / 60 Hz
		220 - 240 V / 50 - 60 Hz

* Zonder stroomkabel en hendels

Kenmerken

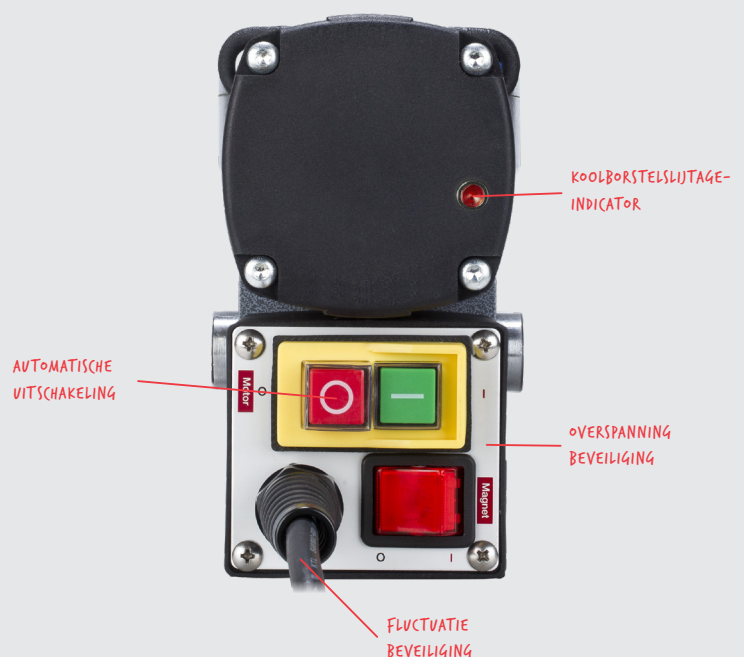
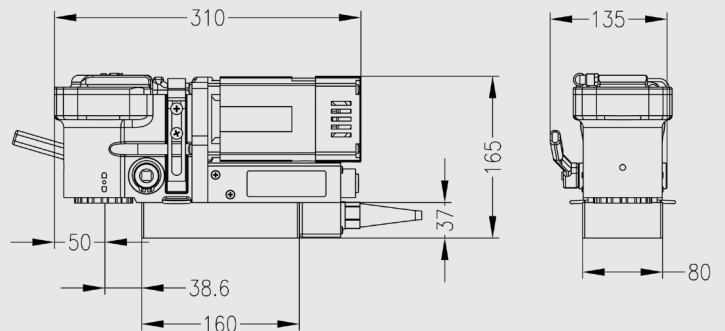

Euroboor stelt alles in het werk om te voldoen aan kwaliteits- en integriteitseisen. Daarom zijn wij als organisatie trots op de erkenning van enkele toonaangevende instanties wereldwijd:



www.euroboor.com