

# ECO.50s+

## Kernboormachine

**EUROBOOR**

FOR PROFESSIONALS BY PROFESSIONALS

### Technische data

	Metrisch	Imperisch
Kernboren	Ø 12 - 50 mm	Ø 1/2" - 2"
Spiraalboren	Ø 1 - 23 mm	Ø 1/16" - 15/16"
Verzinken	Ø 10 - 55 mm	Ø 3/8" - 2 3/16"
Lengte	320 mm	12 5/8"
Breedte	200 mm	7 7/8"
Hoogte	445 - 615 mm	17 1/2" - 24 3/16"
Slag	170 mm	6 11/16"
Gewicht*	12 kg	26,5 lbs
Magneet (l x b x h)	160 x 80 x 42 mm	6 5/16" x 3 1/8" x 1 5/8"
Magnetische kracht	1.700 kg	3.750 lbs
Motor vermogen	1.250 W	11,4 A
Totaal vermogen	1.300 W	11,8 A
Toerental (onbelast)		(I) 380 tpm (II) 690 tpm
Toerental (belast 1.250 W, 11,4 A)		(I) 235 tpm (II) 425 tpm
Opname (Weldon)	MT3 19,05 mm	MT3 3/4"
Krachtvoorziening		110 - 120 V / 60 Hz 220 - 240 V / 50 - 60 Hz

\* Zonder stroomkabel en hendels

### Kenmerken



Oververhittings-beveiliging



Overspannings-beveiliging



Fluctuatie beveiliging



Gyro-Tec



Automatische uitschakeling



Olie gesmeerde versnellingsbak



Koolborstel-slijtage-indicator



2-weg magneet (TempTec)



Magneet LED-indicator (SensorTec)

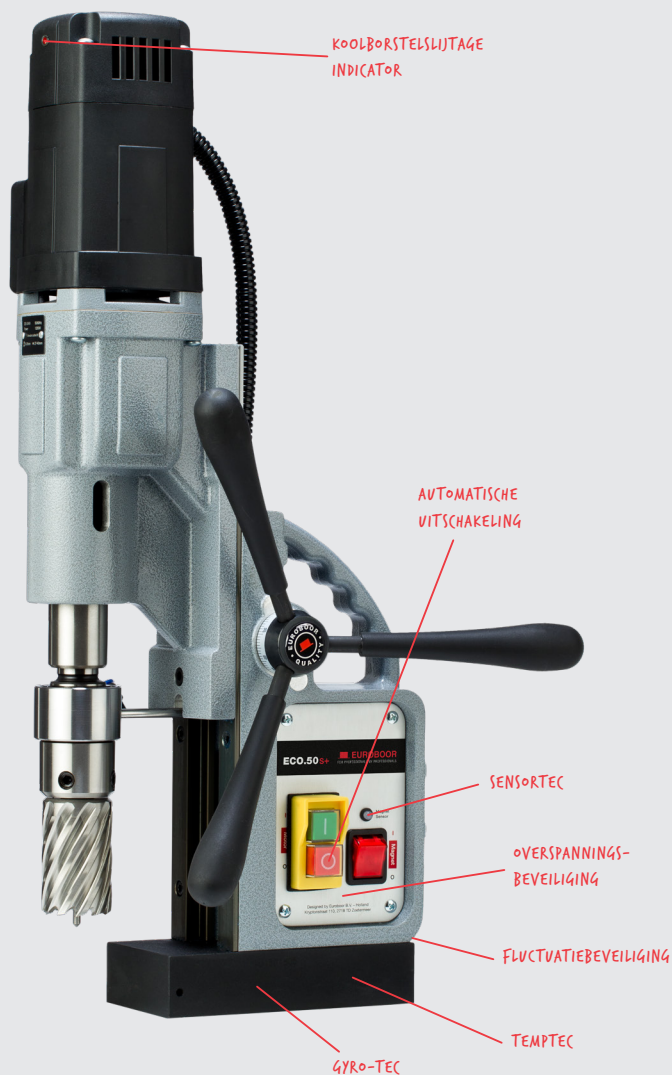
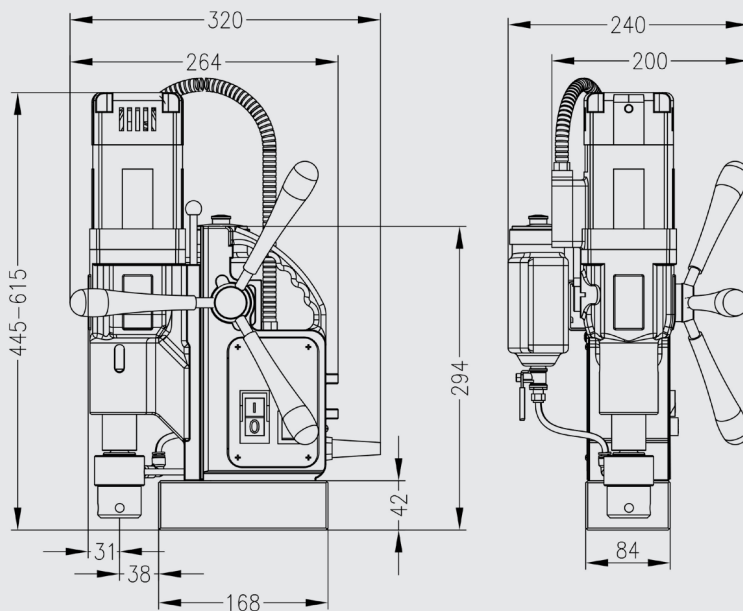

Euroboor stelt alles in het werk om te voldoen aan kwaliteits- en integriteitseisen. Daarom zijn wij als organisatie trots op de erkenning van enkele toonaangevende instanties wereldwijd:



[www.euroboor.com](http://www.euroboor.com)