

ECO.60s+

Kernboormachine

EUROBOOR

FOR PROFESSIONALS BY PROFESSIONALS

Technische data

	Metrisch	Imperisch
Kernboren	Ø 12 - 60 mm	Ø 1/2" - 2 3/8"
Spiraalboren	Ø 1 - 23 mm	Ø 1/16" - 15/16"
Verzinken	Ø 10 - 65 mm	Ø 3/8" - 2 9/16"
Lengte	320 mm	12 5/8"
Breedte	200 mm	7 7/8"
Hoogte	452 - 622 mm	17 13/16" - 24 1/2"
Slag	170 mm	6 11/16"
Gewicht*	12,9 kg	28,4 lbs
Magneet (l x b x h)	168 x 84 x 49 mm	6 5/8" x 3 5/16" x 1 5/16"
Magnetische kracht	1.850 kg	4.080 lbs
Motor vermogen	1.600 W	14,5 A
Totaal vermogen	1.700 W	15,4 A
Toerental (onbelast)	(I) 60 - 275 tpm (II) 100 - 500 tpm	
Toerental belast 1.600 W, 14,5 A)	(I) 60 - 275 tpm (II) 100 - 500 tpm	
Opname (Weldon)	MT3 19,05 mm	MT3 3/4"
Krachtvoorziening	110 - 120 V / 60 Hz 220 - 240 V / 50 - 60 Hz	

* Zonder stroomkabel en hendels

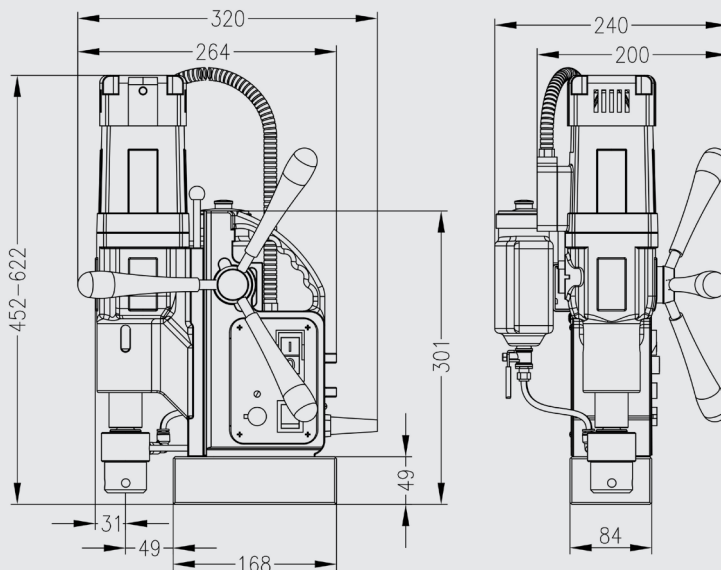

Kenmerken



Toerental regelbaar



Oververhittings-beveiliging



Overspannings-beveiliging



Fluctuatie beveiliging



Gyro-Tec



Automatische uitschakeling



Olie gesmeerde versnellingsbak



Koolborstel-slijtage-indicator



Magneet LED-indicator

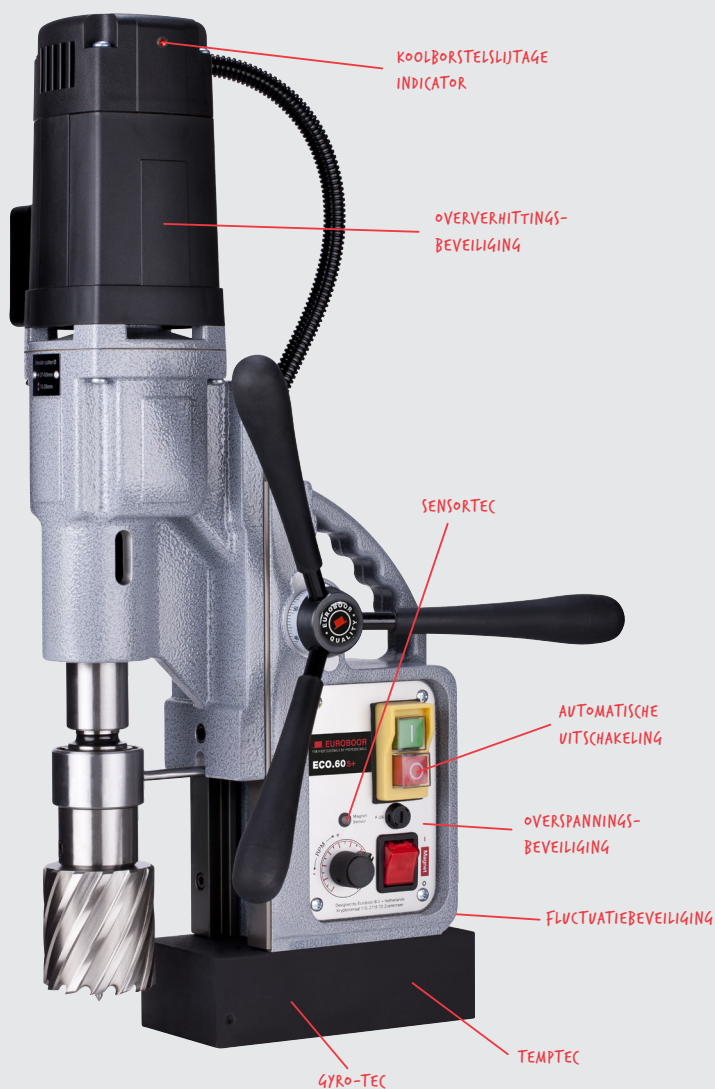

Euroboor stelt alles in het werk om te voldoen aan kwaliteits- en integriteitseisen. Daarom zijn wij als organisatie trots op de erkenning van enkele toonaangevende instanties wereldwijd:



www.euroboor.com