

MBC Guttin

The Expert of Winding and Unwinding



Manual safety chucks



Pneumatic safety chucks



Self-centering pneumatic safety chuck



Assembling



*Expandible Material
and spare parts*



Spreading equipment



Brakes



Others

PRESENTATION

French manufacturer of safety chucks, expandable airshafts, brakes and spreading equipment..

Several patents ensure quality and know-how our company.
Specific products

SIMPLIFIED MAINTENANCE :

- Interchangeability of wear parts within few minutes (**from the front face**)
- 100% Steel manufacturing (**easier to meet specific requirements**)
- Safety chucks with riveted bellows (in accordance with European norms)
- Changing the bladder in few minutes

SECTORS OF ACTIVITIES



ZI de Charancieu - 38490 CHARANCIEU
Tél : + 33 (0) 4 76 32 07 82 - Fax : + 33 (0) 4 76 32 29 56
www.guttin.com - guttinmbc@aliceadsl.fr

MANUAL SAFETY CHUCKS

Manual safety chucks with pivoting disc



Manual safety chucks with sliding disc



Manual safety chucks with axial adjustment



DEFINITION :

- Foot-mounted (Serie 150) or flange-mounted (Serie 250)
- Without shaft end (SFE) or with shaft end (SFE/G)
- With several wear parts :
 - **Type A** Square
 - **Type B** Triangular
 - **Type E** Square 45°
 - **Type V** Double geometry (ensures translation without guiding plates)
 - **Type W** Double geometry (needs guiding plates for translation)

TYPE	ROLL WEIGHT	TORQUE	DIMENSIONS
14-20	150 kg	40 Nm	14 à 20
18-25	400 kg	120 Nm	18 à 25
20-30	800 kg	185 Nm	20 à 30
30-40	1600 kg	350 Nm	30 à 40
40-50	2850 kg	1100 Nm	40 à 50
50-80	7200 kg	2350 Nm	50 à 80
80-120	11 500 kg	9 000 Nm	80 à 120
120-180	22 000 kg	20 000 Nm	120 à 180
180-230	60 000 kg	40 000 Nm	180 à 230

**Safety chucks with
sliding disc
Serie 160—260**

SHAFT ENDS



Others on request

GEOMETRIE

Without wear parts



TYPE A



TYPE E



TYPE B

With wear parts



TYPE APU



TYPE EPU



TYPE BPU



TYPE AVPU



TYPE AWPU

Safety chucks serie 160/260

*MBC
Guttin*



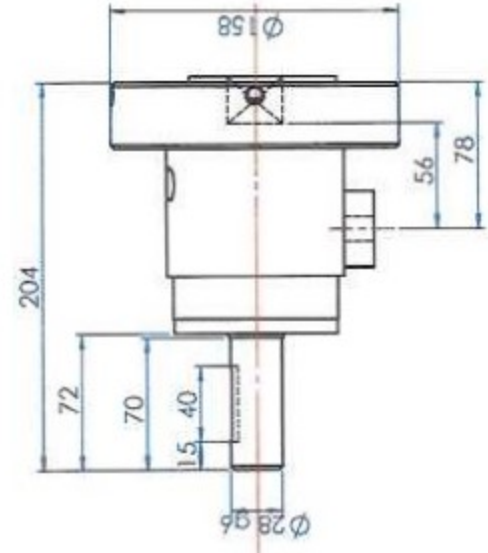
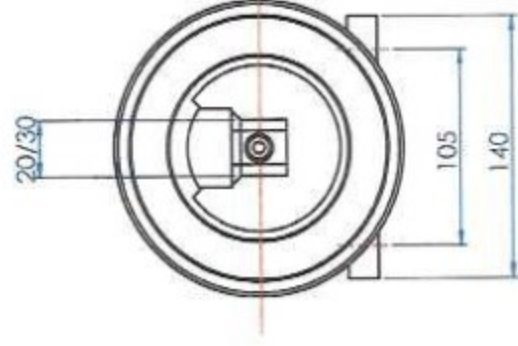

SFE/G

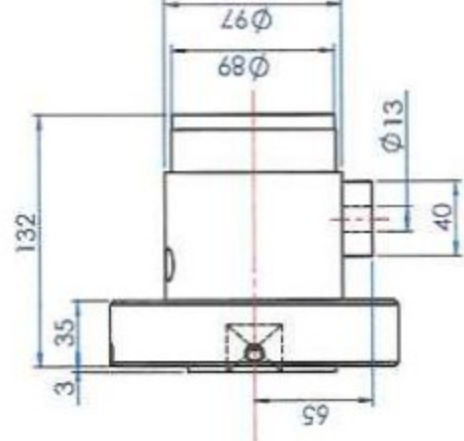

SFE

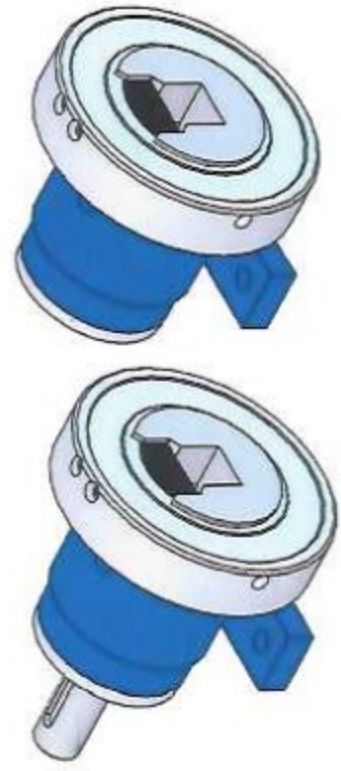

SAFETY CHUCK SERIE 160 20/30
MBC
Guttin
 Square : 20 to 30 depth 22
 Rollweight : 8000 N
 Torque : 185 Nm



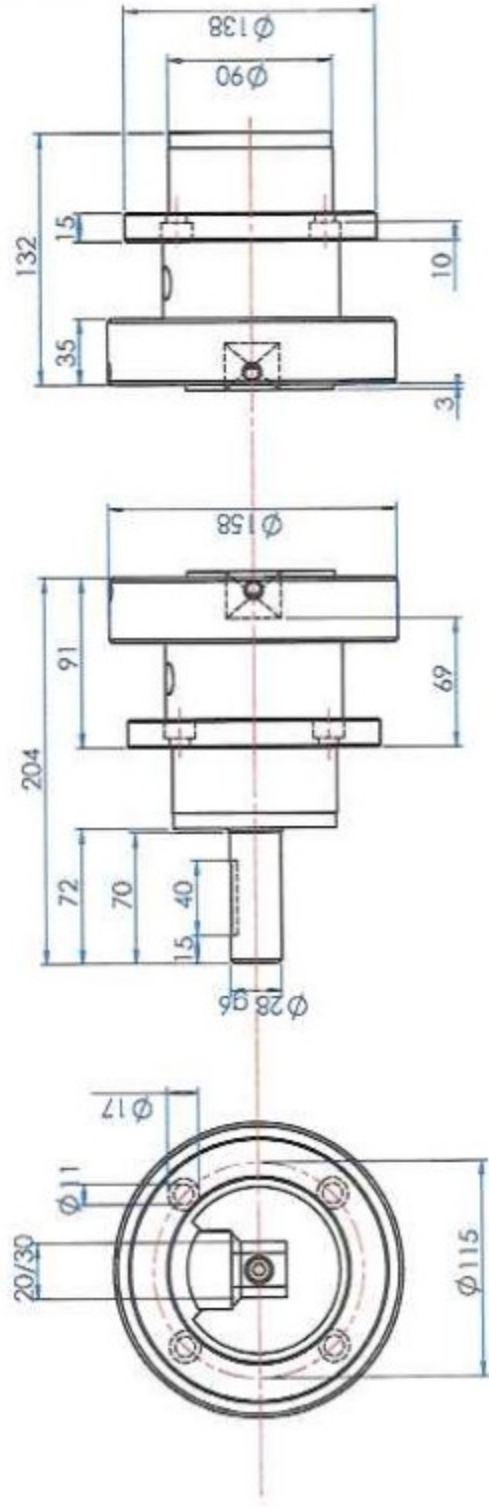

SFE/G

SFE

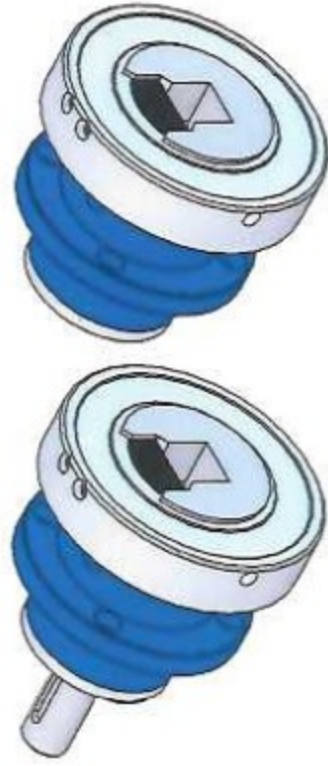

SAFETY CHUCK SERIE 260 20/30

**MBC
Guttin**

Square : 20 to 30 depth 22

Rollweight : 8000 N

Torque : 185 Nm



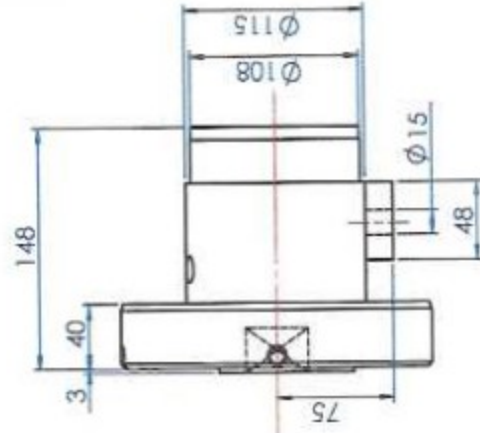
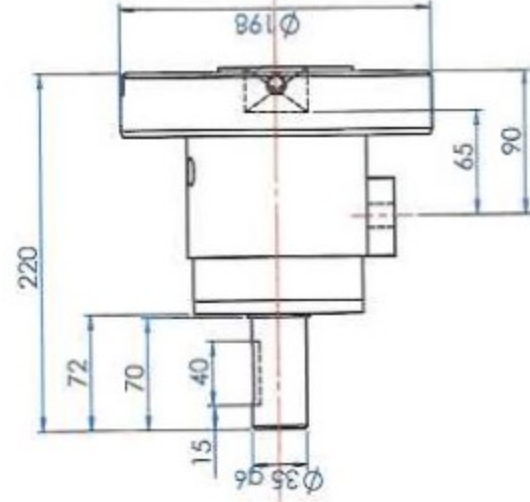
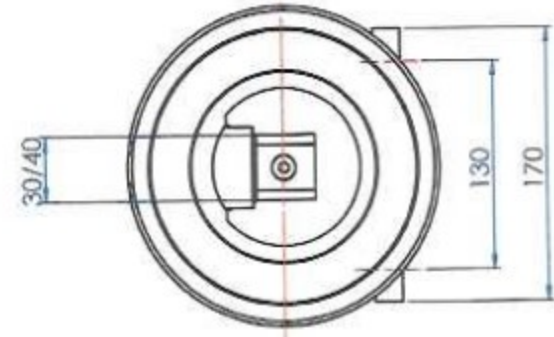

SFE/G

SFE



SAFETY CHUCK SERIE 160 30/40
MBC
Guttin

Square : 30 to 40 depth 25

Rollweight : 16000 N

Torque : 350 Nm



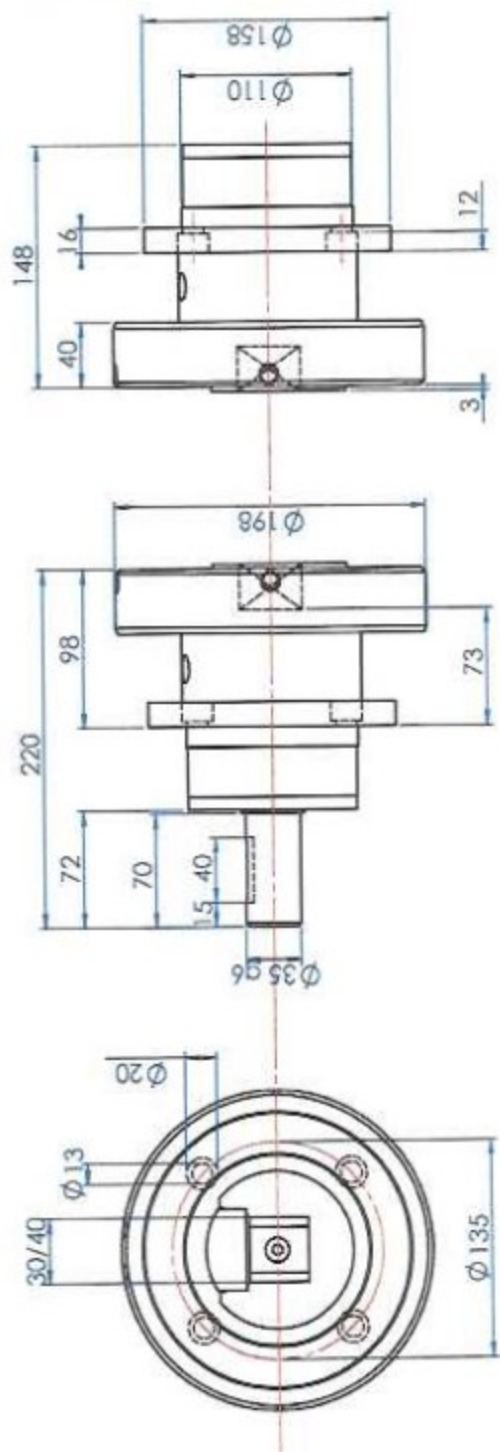

SAFETY CHUCK SERIE 260 30/40
 Square : 30 to 40 depth 25
 Rollweight : 16000 N
 Torque : 350 Nm



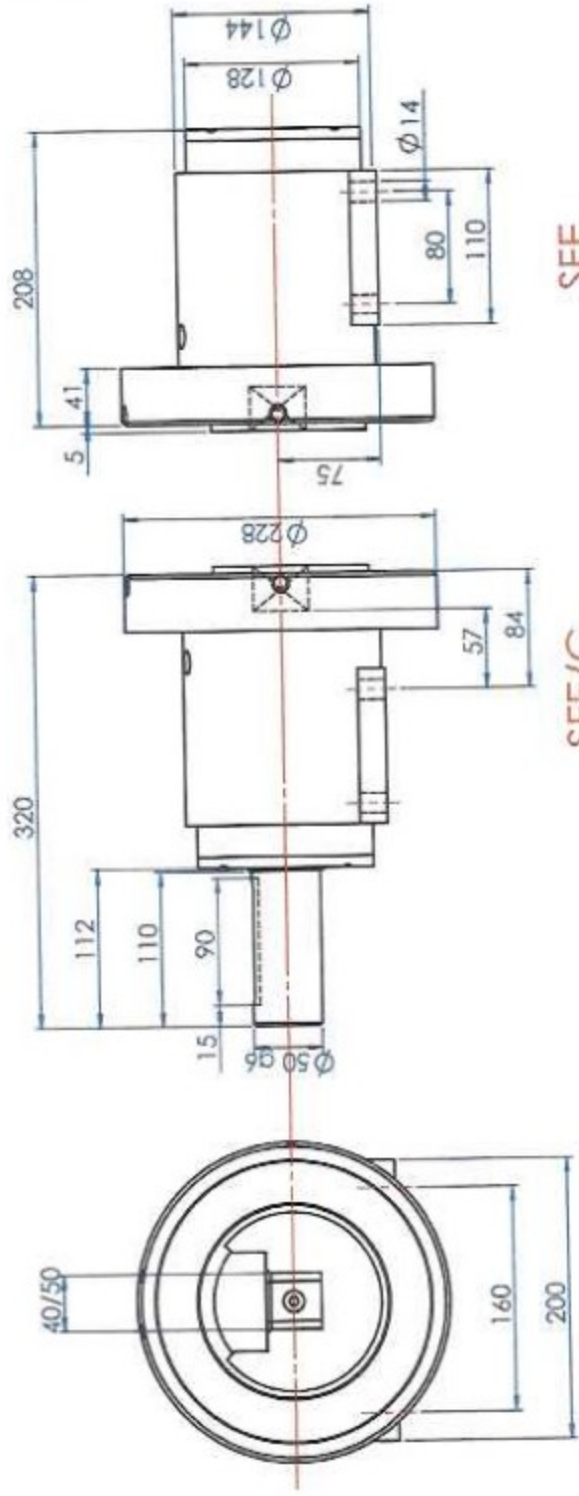

SFE/G

SFE



SAFETY CHUCK SERIE 160 40/50 *MBC*
Guttin

Square : 40 to 50 depth 27

Rollweight : 28500 N

Torque : 1100 Nm



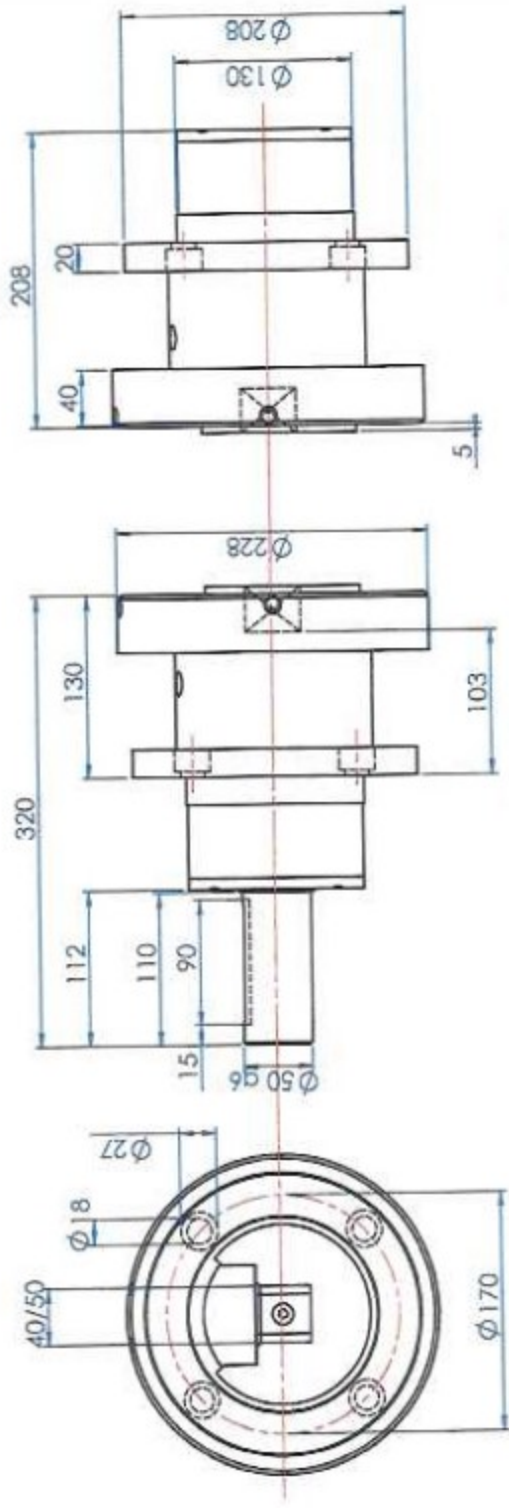

SFE/G

SFE



SAFETY CHUCK SERIE 260 40/50

MBC
Guttin

Square : 40 to 50 depth 27

Rollweight : 28500 N

Torque : 1100 Nm

