

**A**



**CE 0082**

EN361:2002 EN358:1999 EN813:2008  
EN1497:2007 (P-71CR)

**B**

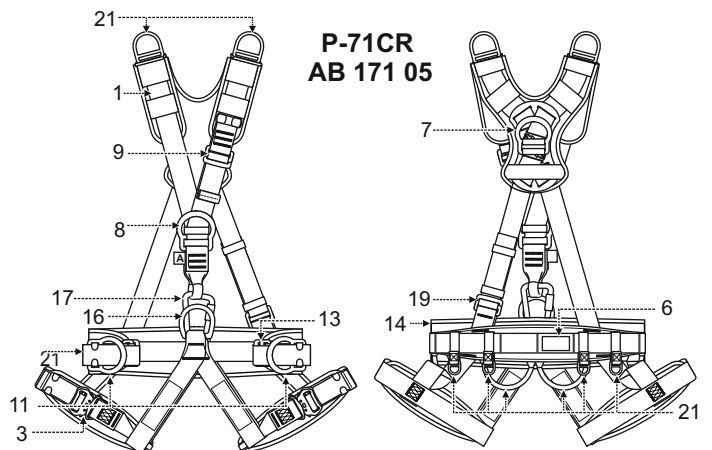
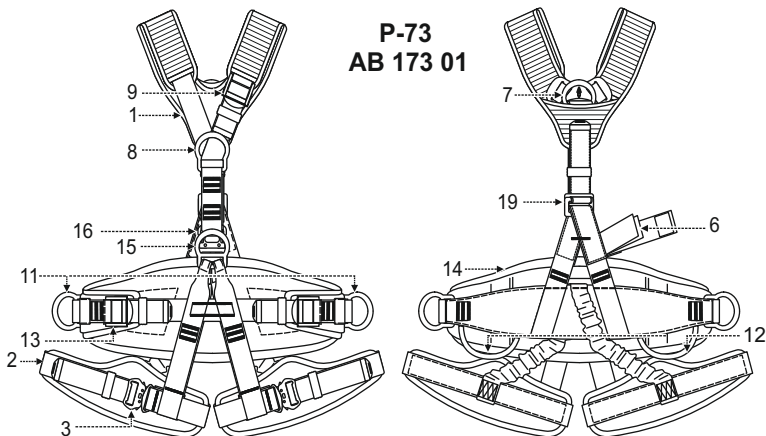
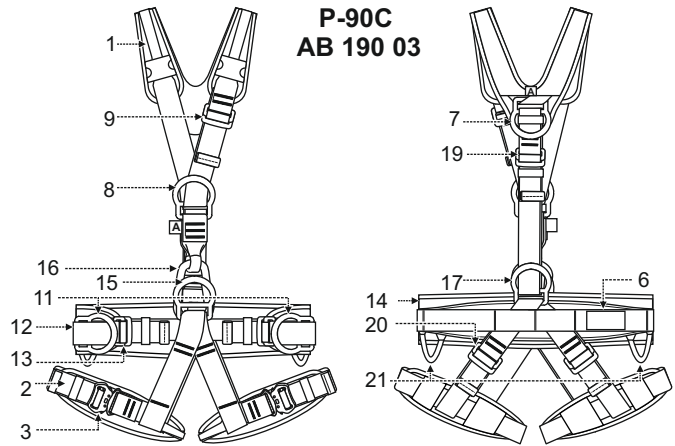
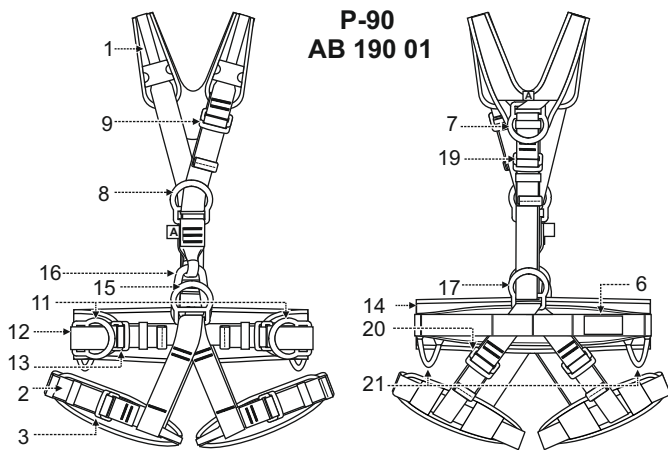
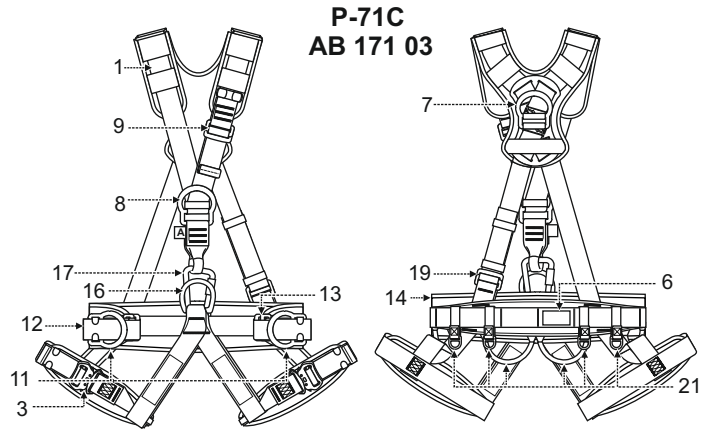
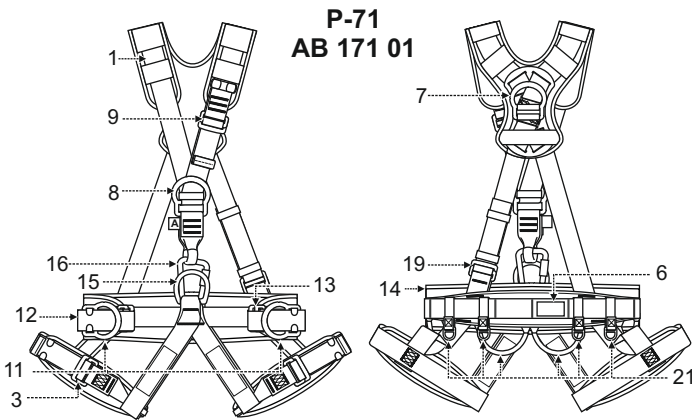
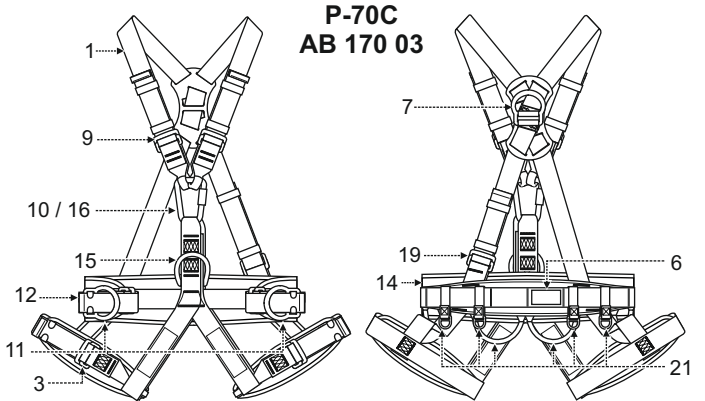
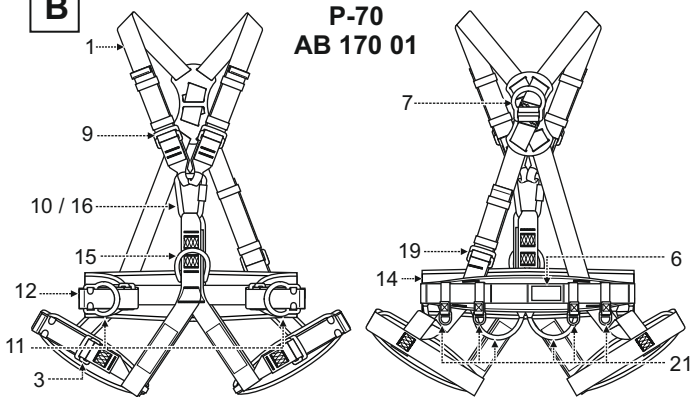

**C**

	S	M-XL	XXL	XXXL
H	155 cm - 170 cm	164 cm - 180 cm	180 cm - 195 cm	190 cm - 210 cm
W	75 cm - 110 cm	85 cm - 120 cm	90 cm - 140 cm	95 cm - 150 cm
C	70 cm - 90 cm	85 cm - 100 cm	100 cm - 130 cm	110 cm - 140 cm
T	40 cm - 60 cm	50 cm - 75 cm	60 cm - 85 cm	75 cm - 100 cm

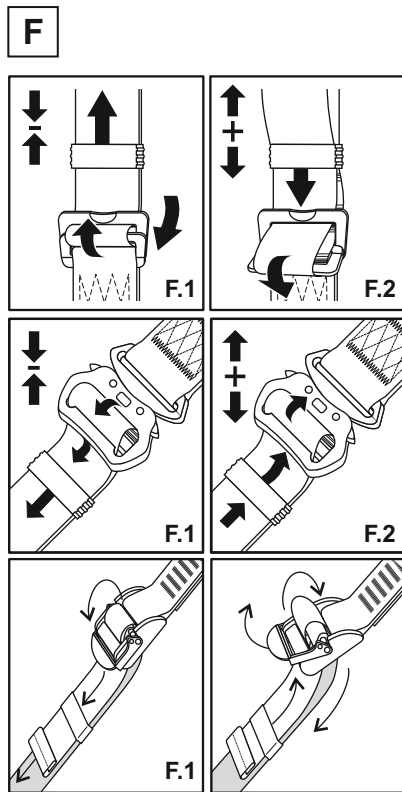
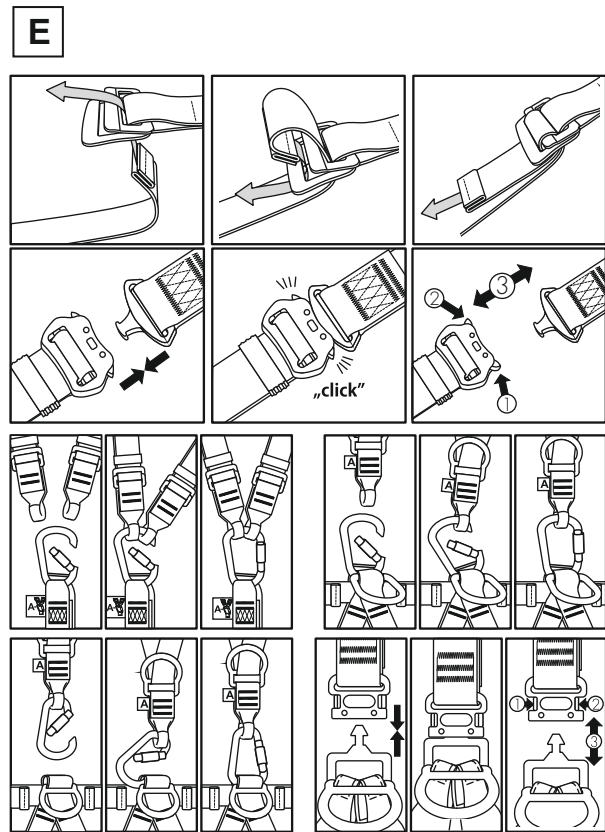
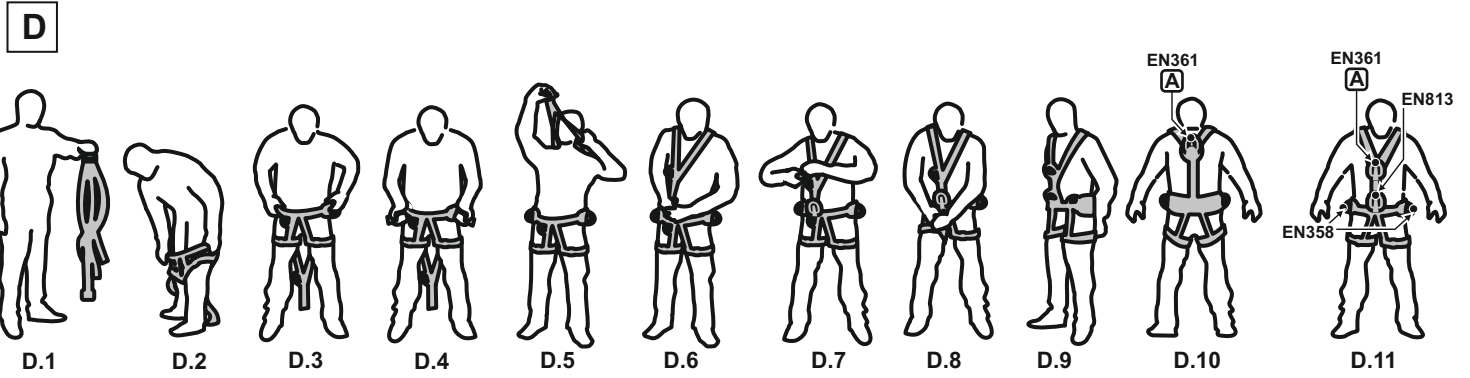

**G**

a — **P-.....**  
 b — **SAFETY HARNESS**  
 c — Ref. .... ..  
 d — Size: .....

k — .. cm - ..... cm

e — Date of manufacture: **MM/YYYY**

f — Serial number: **XXX XXX**

g — **EN 361:2002**  
**EN 358:1999**  
**EN 813:2008**  
**EN 1497:2007**

h — **CE 0082**

i — **max. 140 kg**

j —

l — **pelgrim SAFETY**

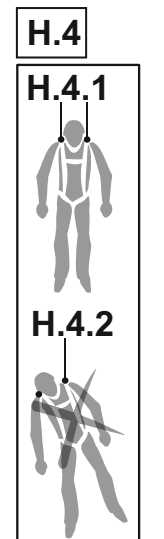
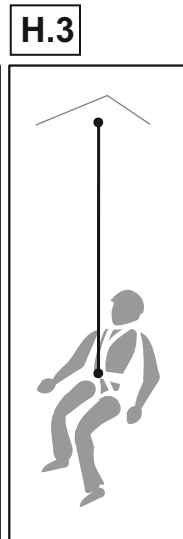
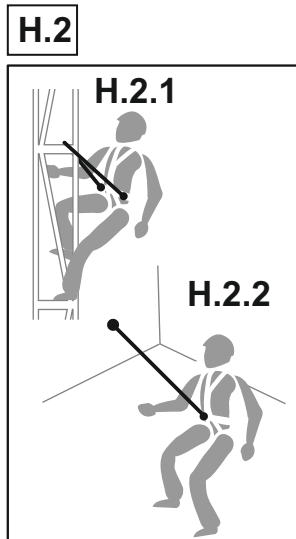
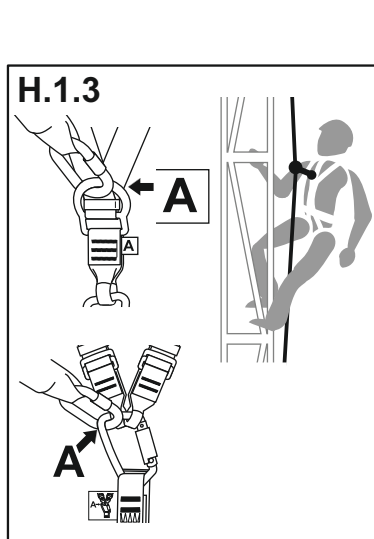
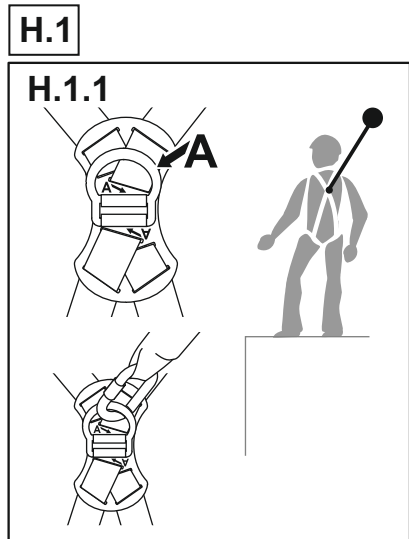

GB - NOTICE: Read and fully understand these instructions before using this equipment.

## A. DESCRIPTION

Safety harness is a body holding device intended to be used in fall protection systems described in EN 363 standard.

The harness is certified and complying with the standard:

- EN 361:2002 as a full body harness intended to be used in fall arrest systems.
- EN 358 as a work positioning belt to be used with work positioning equipment;
- EN 813 as a sit harness for supporting a person in a sitting position with a physical support to the lower back of the user during work at height in suspension.
- EN 1497 as a rescue harness for supporting the full body of the user in right position during rescue operation. Intended to be used during normal working activities.

Basic materials:

- webbings - polyester and polyamide
- connecting/adjustment buckles: steel and aluminium
- attachment D-rings: steel and aluminium

## B. NOMENCLATURE

1. Shoulder strap.
2. Leg strap.
3. Leg strap connecting/adjustment buckle.
4. Chest strap.
5. Chest strap connecting/adjustment buckle.
6. Identity label.
7. Fall arrest (A) back attachment D-ring EN361.
8. Fall arrest (A) front attachment D-ring EN 361.
9. Shoulder strap adjustment buckle.
10. Fall arrest (A) connector EN361.
11. Lateral belt work positioning D-rings EN 358.
12. Work positioning belt waist strap.
13. Work positioning belt adjustment buckle.
14. Belt pad.
15. Front waist sit harness D-ring EN 813.
16. Shoulder strap connector.
17. Back waist work positioning/restraint D-ring EN358.
18. Shoulder strap rescue harness D-rings EN1497.
19. Dorsal strap adjustment buckle.
20. Rear leg straps adjustment buckle.
21. Tool loops – to be used with hand tools of max. weight 2 kg.

## C. SIZES

The harness is manufactured in four sizes:

- small: S
- universal: M-XL
- extra-large: XXL
- extra, extra-large: XXL

## D. DONNING THE HARNESS:

- D.1 Hold the harness by dorsal D-ring. Shake the harness to allow all straps to fall in place.
- D.2 Unbuckle the front shoulder strap connector. Step into the leg loops putting one leg through each leg loop.
- D.3 Pull the harness up.
- D.4 Tighten the waist belt strap. The strap should fit tight around the waist.
- D.5 Take the shoulder straps from the back and slide your head through it, taking care not to twist the straps.
- D.6 Connect shoulder loop to the connector located on the waist strap behind the chest D-ring.
- D.7 Adjust the shoulder straps so the harness fits the body, not too tight.
- D.8 Adjust the leg straps. The straps should fit the legs.
- D.9 Adjust the height of the leg straps by the rear adjustment straps.
- D.10 Back attachment D-ring must be positioned between shoulder blades.
- D.11 Front attachment D-ring or attachment linked loops must be centred on lower chest. Front sit harness D-ring must be centred on the waist.

## E. CONNECTING THE BUCKLES

### F. ADJUSTING THE STRAPS

- F.1 Tightening
- F.2 Loosening

### G. MEANING OF THE MARKING

- a) Model symbol;
- b) Device type;
- c) Reference number;
- d) Harness size;
- e) Month and year of manufacture;
- f) Serial number of the harness;
- g) number/year of European standards;
- h) CE mark and number of the notified body controlling manufacturing of the equipment;
- i) Caution: read and understand the instruction manual before use;
- j) Maximum rated load - 140 kg;
- k) Waist belt size in cm;
- l) Identification of the harness manufacturer or distributor.

## H. ATTACHING THE HARNESS

### H.1 ATTACHING FALL ARRESTS SYSTEMS – EN361

Fall arrest system can be attached only to the fall arrest attachment point of full body harness EN 361 marked with capital letter A:

- directly to the back D-ring (H.1.1)
- to extension strap (H.1.2). The length of the extension strap must be taken into consideration when required free clearance below working platform is calculating.
- to the front attachment D-ring placed on the chest strap (H.1.3).
- to the front attachment loops. The loops marked with a half of letter must be linked together when attached to the fall arrest system (H.1.4). It is strictly forbidden to attach a fall arrest system to a single loop with a half of letter A (H.1.5).

### H.2. CONNECTING WORK POSITIONING SYSTEMS – EN358

Work positioning or restraint system can be attached to the work positioning belt EN 358 D-rings or to the frontal waist sit harness EN813 D-ring. Work positioning system must be anchored to the point of construction that is situated at waist level or above. Work positioning lanyard must be kept taut during use. It is strictly forbidden to use the work positioning belt EN358 D-rings or loops for fall arrest purposes. The belt shouldn't be used if there is a foreseeable risk of the user becoming suspended or being exposed to unintended tension by the waist belt. When using a work positioning system, the user normally relies on the equipment for support, therefore it is essential to consider the need of using a back-up, e.g. a fall arrest system.

### H.3 CONNECTING ROPE ACCESS SYSTEMS TO SIT HARNESS – EN813

Rope access system can be attached to the frontal waist D-ring or loops of the sit harness EN813. The anchor point of the rope access system must be located above the user. Before use the sit harness the first time the user should carry out a suspension test in a safe place to ensure that the sit harness is the correct size, has sufficient adjustment and is of an acceptable comfort level for the intended use. It is strictly forbidden to use the rescue harness EN813 D-ring or loops for fall arrest purpose.

### H.4 CONNECTING RESCUE SYSTEMS – EN1497

Double rescue harness loops or D-rings placed on the shoulder straps can be used linked together only for rescue purposes (H.4.1). Don't use the single loop to link with 1 connector or lanyard, because the risk is to strangle (H.4.2). Before use the rescue harness for the first time the user should carry out a suspension test in a safe place to ensure that the rescue harness is the correct size, has sufficient adjustment and is of an acceptable comfort level for the intended use. EN1497 D-rings or loops are for rescue purpose only. It's not allowed to use rescue harness D-rings or loops for fall arrest purpose.

## I. PERIODIC INSPECTIONS

Safety harness must be inspected at least once every 12 months from the date of first use. Periodic inspections must only be carried out by a competent person who has the knowledge and training required for personal protective equipment periodic inspections. Depending upon the type and environment of work, inspections may be needed to be carried out more frequently than once every 12 months. Every periodic inspection must be recorded in the Identity Card of the equipment.

## J. MAXIMUM LIFESPAN OF THE EQUIPMENT

The maximum lifespan of the harness is 10 years from the date of manufacture.

**ATTENTION:** The harness maximum lifetime depends on the intensity of usage and the environment of usage. Using the harness in rough environment, marine environment, contact with sharp edges, exposure to extreme temperatures or aggressive substances, etc. can lead to the withdrawal from use even after one use.

## K. WITHDRAWAL FROM USE

The harness must be withdrawn from use immediately and destroyed when it has been used to arrest a fall or it fails to pass inspection or there are any doubt as to its reliability.

## L. THE ESSENTIAL PRINCIPLES FOR USERS OF PERSONAL PROTECTIVE EQUIPMENT AGAINST FALLS FROM A HEIGHT:

- personal protective equipment shall only be used by a person trained and competent in its safe use.
- personal protective equipment must not be used by a person with medical condition that could affect the safety of the equipment user in normal and emergency use.
- a rescue plan shall be in place to deal with any emergencies that could arise during the work.
- being suspended in PPE (e.g. arresting a fall), beware of suspension trauma symptoms.
- to avoid symptoms of suspension trauma, be sure that the proper rescue plan is ready for use. It is recommended to use foot straps.
- it is forbidden to make any alterations or additions to the equipment without the manufacturer's prior written consent.
- any repair shall only be carried out by equipment manufacturer or his certified representative.
- personal protective equipment shall not be used outside its limitations, or for any purpose other than that for which it is intended.
- personal protective equipment should be a personal issue item.
- before use ensure about the compatibility of items of equipment assembled into a fall arrest system. Periodically check connecting and adjusting of the equipment components to avoid accidental loosening or disconnecting of the components.
- it is forbidden to use combinations of items of equipment in which the safe function of any one item is affected by or interferes with the safe function of another.
- before each use of personal protective equipment it is obligatory to carry out a pre-use check of the equipment, to ensure that it is in a serviceable condition and operates correctly before it is used.

