

# Kalfire E-one 130 installation instructions

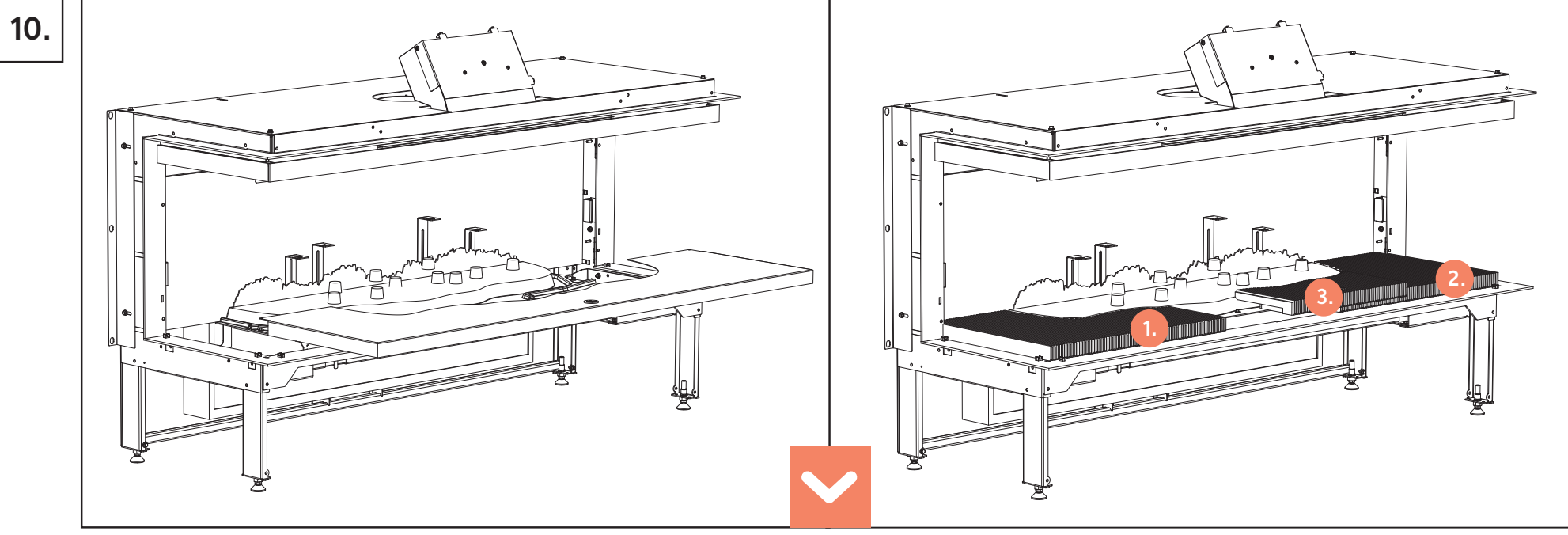
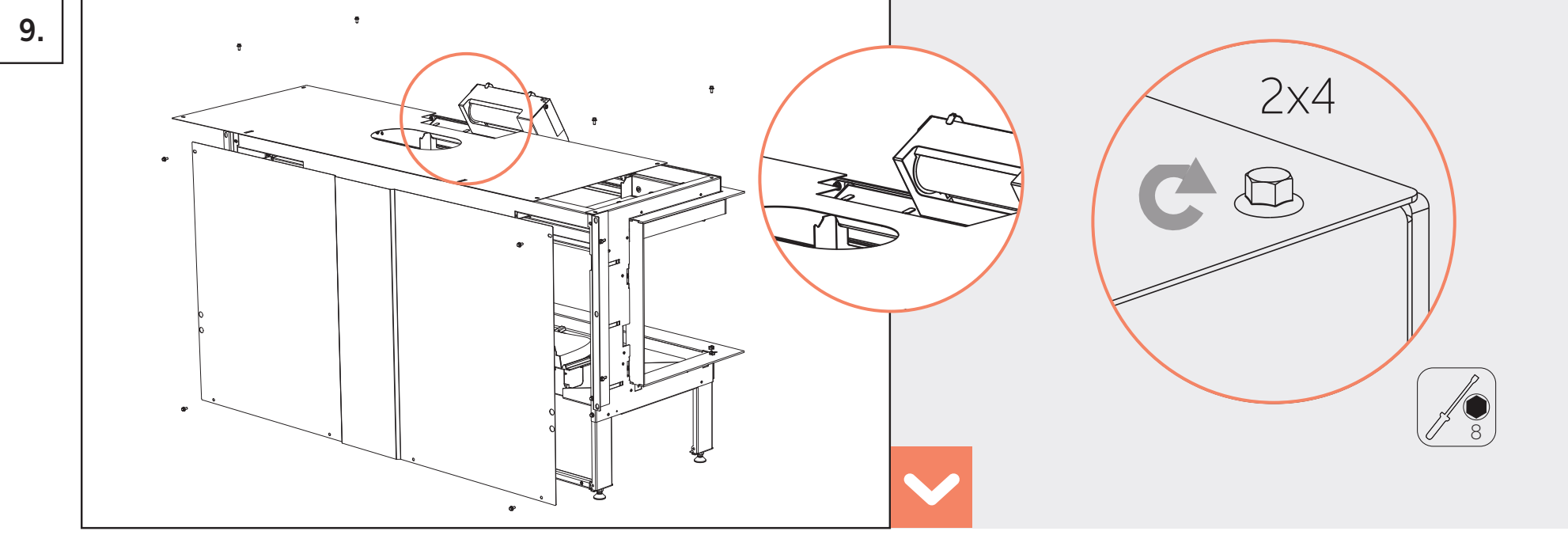
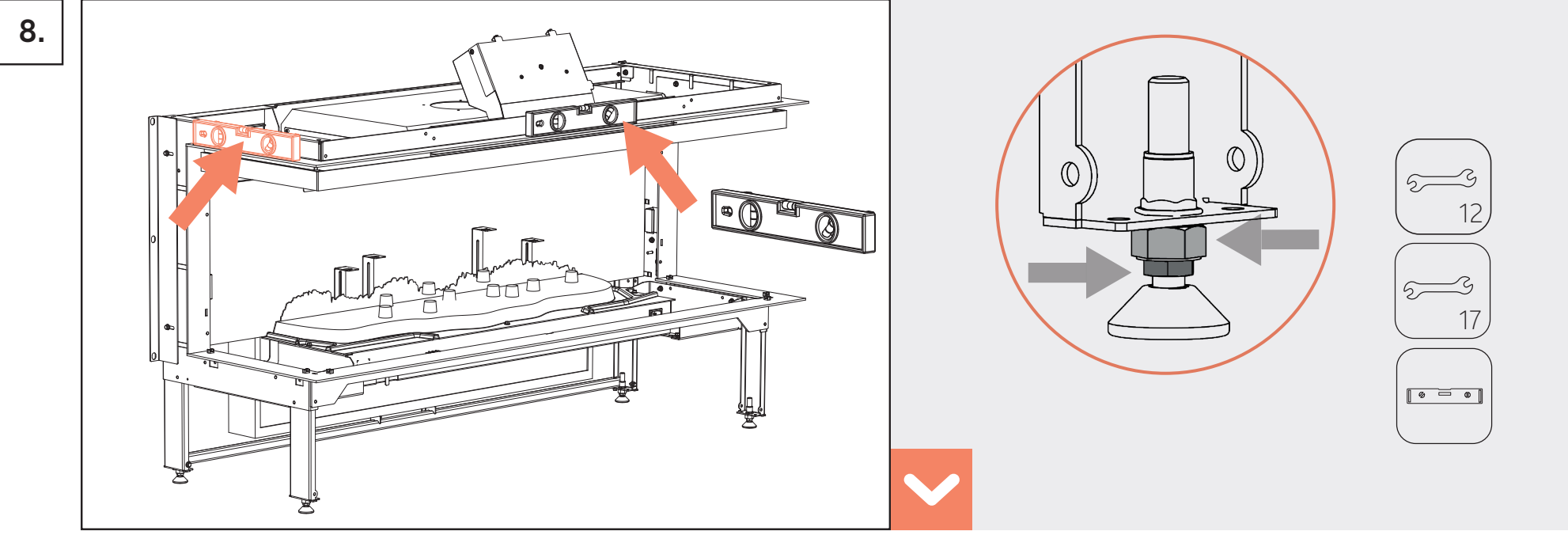
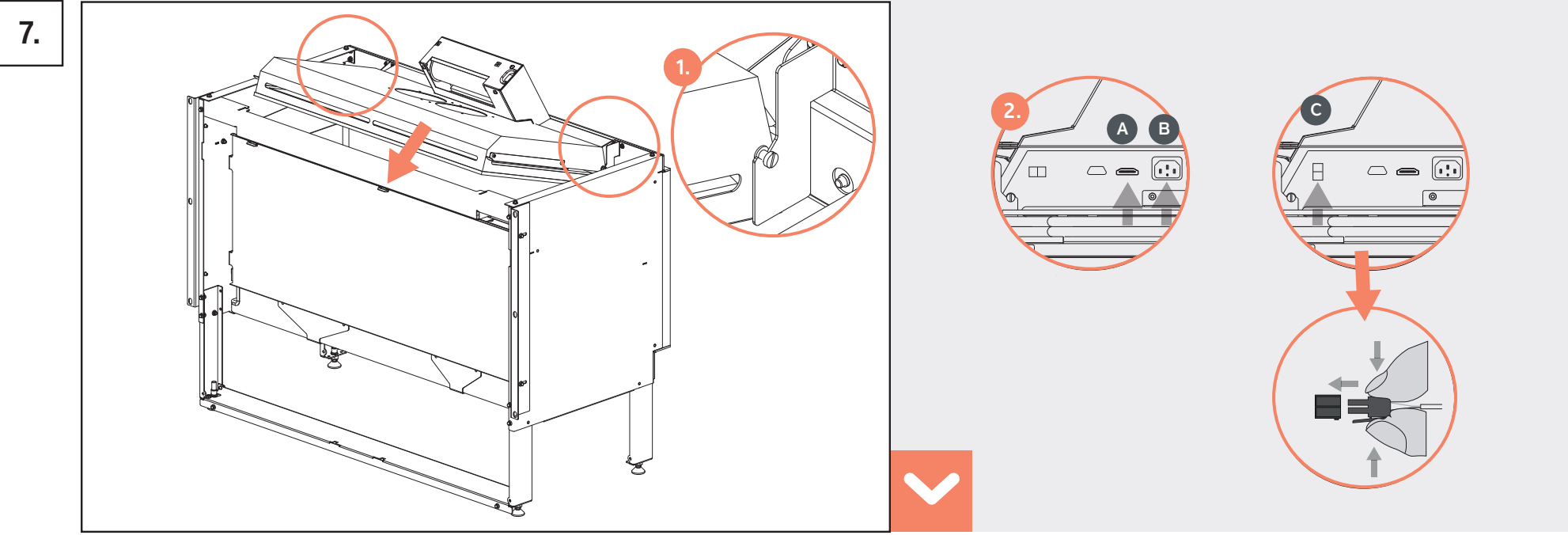
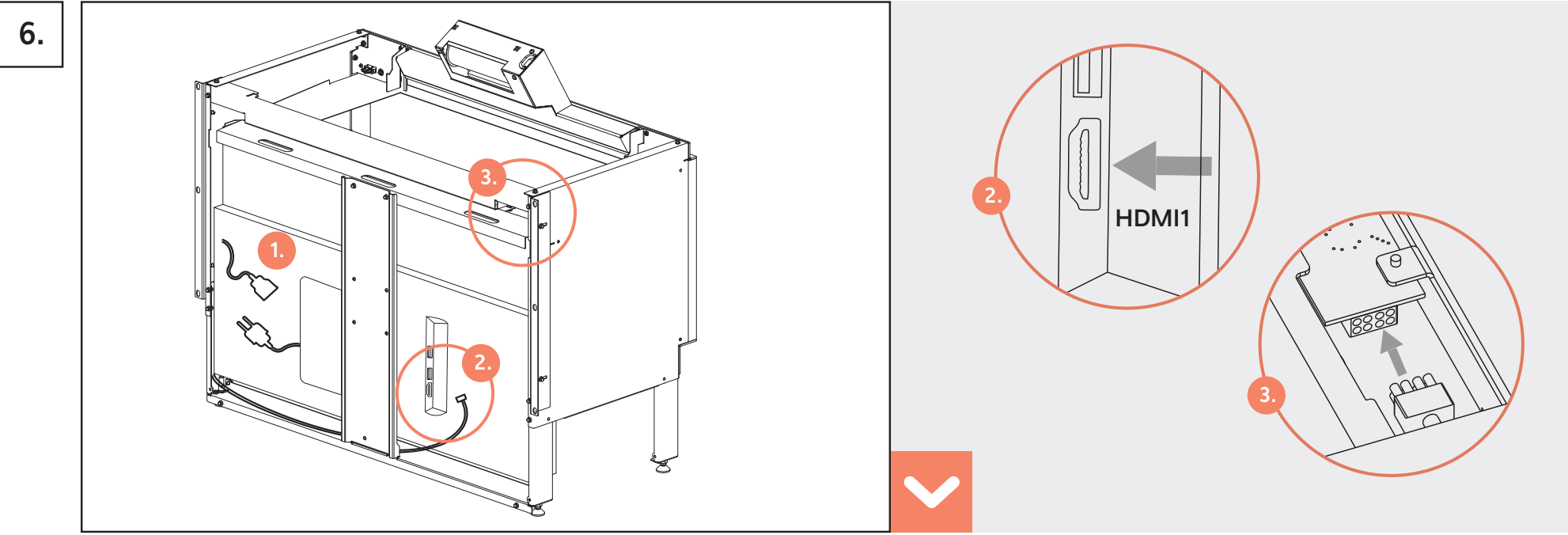
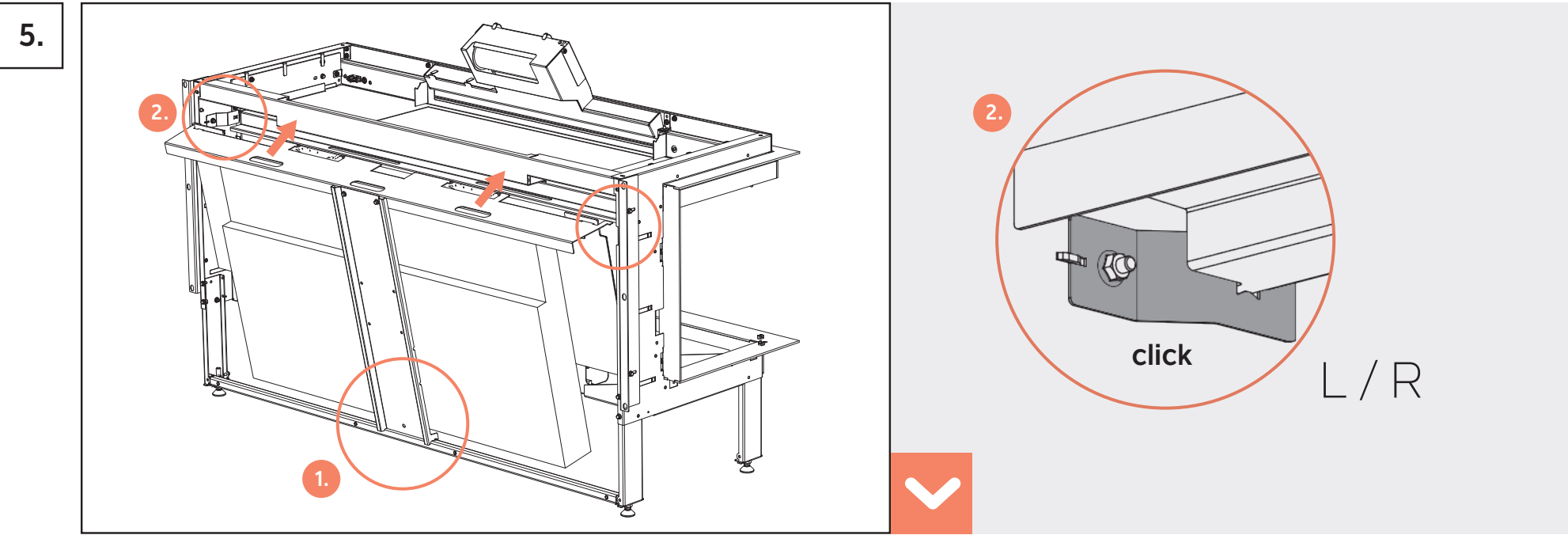
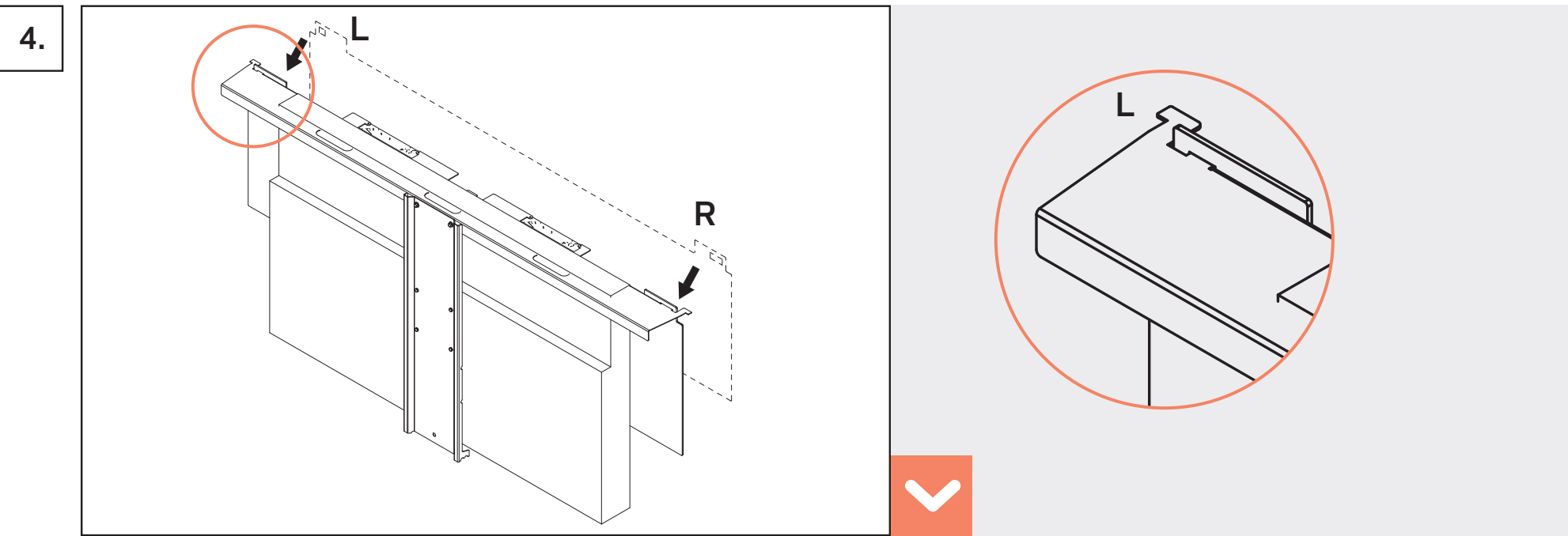
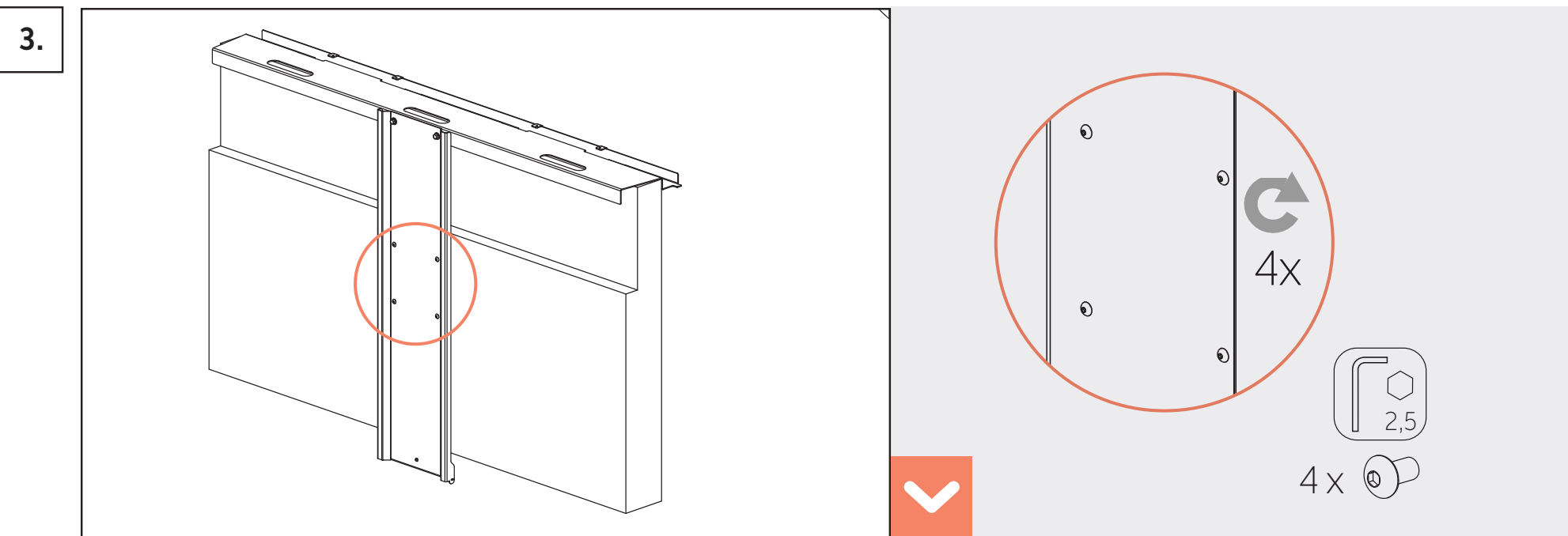
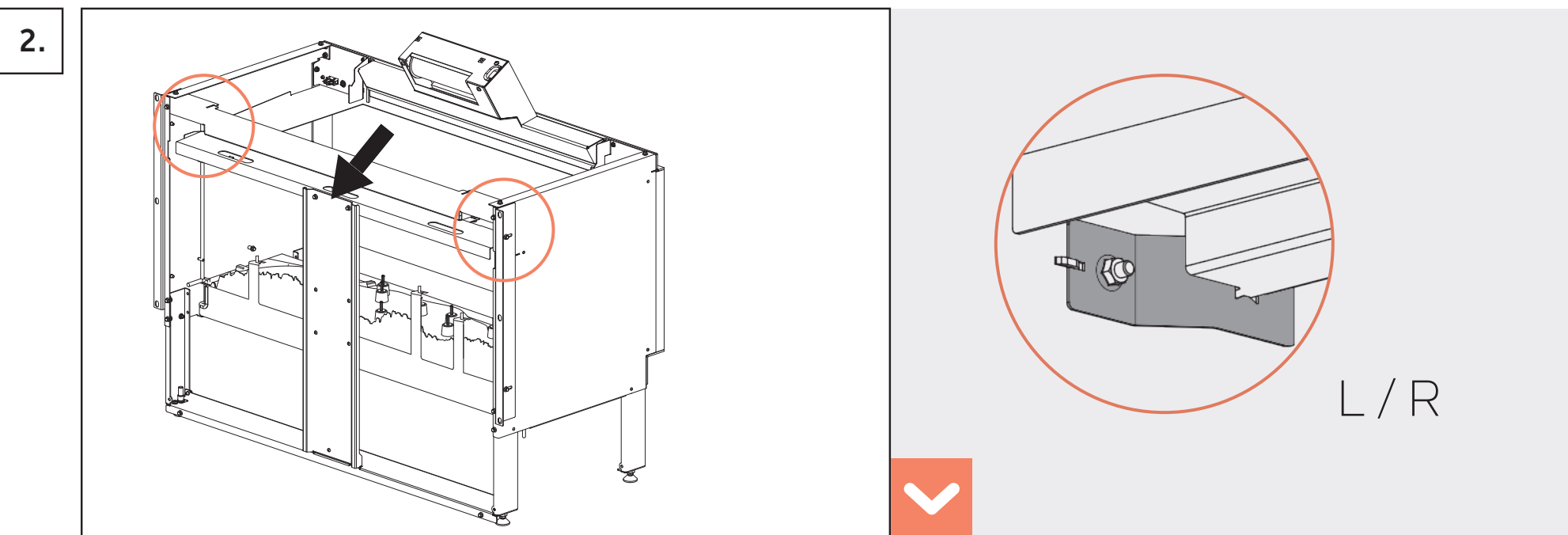
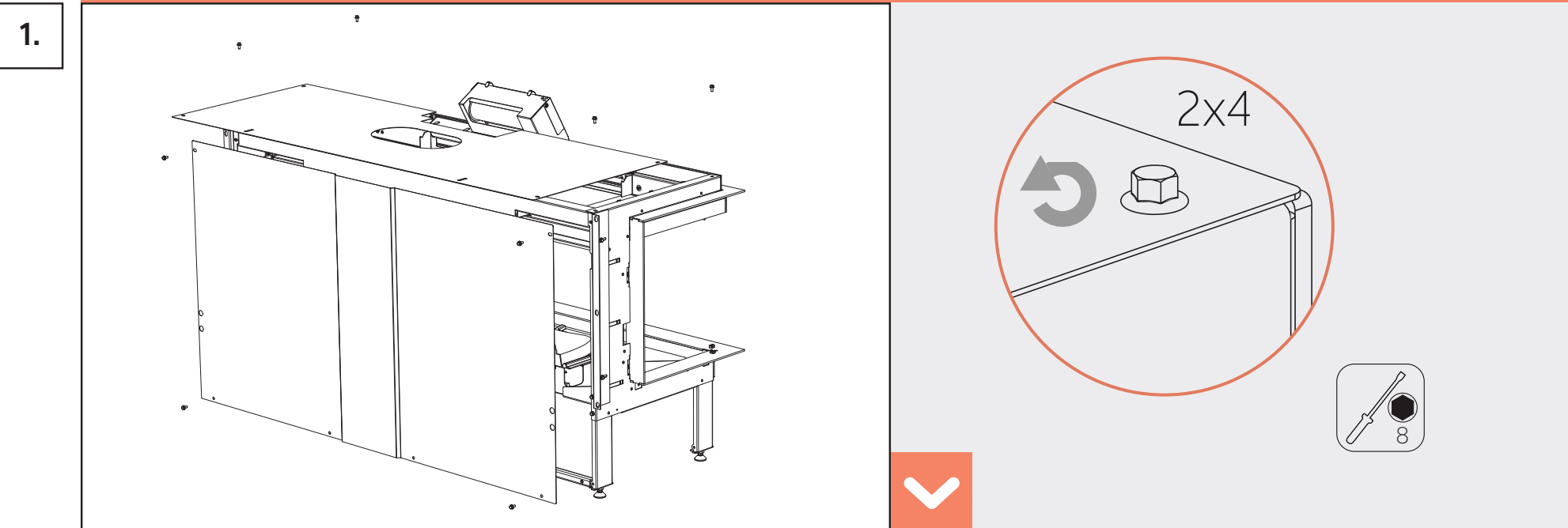

## NL

### Controle bij ontvangst

- Controleer bij ontvangst het volgende:
1. Controleer of de verpakking niet beschadigd is.
  2. Controleer glaspanelen en schermen van het product op breuken.
  3. Controleer of alle onderstaande onderdelen compleet zijn:

- Haard
- Decoratieset
- Bovenscherm
- Spiegelsluit
- Frontglas
- E-one remote control (afstandsbediening)
- Installatie- en gebruiksvorschrift
- Inbus bolkop schroeven 4x
- Voedingskabel
- Bodemplaten
- Ziglas: hoekmodel 1x, 3-zijdig model 2x
- Blokkenvanger: hoekmodel 1x, 3-zijdig model 2x
- Blokkenvangerdopjes: hoekmodel 1x, 3-zijdig model 2x
- Afdekstrip: hoekmodel 1x, 3-zijdig model 2x
- Optie Dual HD Flame technology:
  - achterscherm
  - maskerscherm

### CE verklaring

De E-one voldoet aan de volgende CE normen:

RED richtlijn:	2014/53/EU
Veiligheid:	IEC 62368-1 EN 60335-2-30
Gezondheid:	EN 62311
EMC:	EN 55032 EN 301 489-1 EN 61000-3 EN 300 328 EN 300 220-2 EN 301 893

Radio:

## EN

### Receiving inspection

When using electrical appliances, necessary precautions must always be taken to reduce and/or prevent the risk of fire, electric shock, and personal injury:

1. Verify that the packaging is not damaged
2. Check the glass panels and display screens of the product for cracks.
3. Check that you have received all of the following parts:
  - Fireplace
  - Decoration set
  - Top screen
  - Glass reflector
  - Front window
  - E-one remote control
  - Installation and operating instructions
  - Hexagon socket head screws 4x
  - Power cable
  - Bottom plates
  - Side window: corner model 1x, 3-sided model 2x
  - Log retainer: corner model 1x, 3-sided model 2x
  - Log retainer caps: corner model 1x, 3-sided model 2x
  - Cover strip: corner model 1x, 3-sided model 2x
  - Option Dual HD Flame technology:
    - Rear screen
    - Masking plate

### CE declaration

RED directive:	2014/53/EU
Safety:	IEC 62368-1 EN 60335-2-30
Health:	EN 62311
EMC:	EN 55032 EN 301 489-1 EN 61000-3 EN 300 328 EN 300 220-2 EN 301 893

Radio:

## FR

### Vérification à la réception

- À la réception, vérifiez les points suivants:
1. Vérifiez que l'emballage n'est pas endommagé.
  2. Vérifiez que les panneaux de verre et les écrans ne sont pas fissurés.
  3. Vérifiez que toutes les pièces ci-dessous sont complètes:

- Foyer
- Jeu de bûches
- Écran (Single HD Flame technology)
- Miroir
- Vitre avant
- Télécommande E-one
- Manuel d'installation et d'utilisation
- Vis à six pans creux 4x
- Câble d'alimentation
- Plaques de fond
- Vitre latérale: modèle en coin (1x), modèle 3-côtés (2x)
- Retenue des bûches: modèle en coin (1x), modèle 3-côtés (2x)
- Capuchon pour le retenue des bûches.
- Bande de couverture: modèle en coin (1x), modèle: 3-côtés (2x)
- (option Dual HD Flame technology:
  - écran arrière
  - écran de marquage

### Déclaration CE

L'E-one répond aux normes CE suivantes:	
Directive RED:	2014/53/EU
Sécurité:	IEC 62368-1 IEC/EN 60335-2-30
Santé:	EN 62311
EMC:	EN 55032 EN 301 489-1 EN 61000-3 EN 300 328 EN 300 220-2 EN 301 893

Radio:

## DE

### Kontrolle bei der Lieferung

- Überprüfen Sie bei der Lieferung folgende Punkte:
1. Stellen Sie sicher, dass die Verpackung nicht beschädigt ist.
  2. Überprüfen Sie Front- und Spiegelscheibe sowie die Bildschirme auf Brüche.
  3. Überprüfen Sie, ob alle Teile vollständig vorhanden sind:

- Kamin: E-one 100F oder E-one 100F FR
- Kaminfüllung
- Oberer Bildschirm
- Spiegelscheibe
- Frontscheibe
- E-one Fernbedienung
- Installations- und Betriebsanleitung
- Innensechskantschrauben: 4x
- Stromkabel
- Feuerraumboden
- Seitenscheibe: Eckmodell 1x, 3-seitiges Modell 2x
- Stehrost: Eckmodell 1x, 3-seitiges Modell 2x
- Stehrostkappen: Eckmodell 1x, 3-seitiges Modell 2x
- Abdeckleiste: Eckmodell 1x, 3-seitiges Modell 2x
- Option Dual HD Flame Technology:
  - Bildschirm Rückwand
  - Abdeckschirm

### CE Erklärung

Der Kalfire E-one erfüllt die folgenden CE-Normen:

RED Direktive:	2014/53/EU
Sicherheit:	IEC 62368-1 EN 60335-2-30
Gesundheit:	EN 62311
EMC:	EN 55032 EN 301 489-1 EN 61000-3 EN 300 328 EN 300 220-2 EN 301 893

Radio:

### Allgemeine Sicherheitshinweise

Bei der Verwendung von Elektrogeräten sollten stets die erforderlichen Vorsichtsmaßnahmen getroffen werden, um die Gefahr von Feuer, Stromschlag und Personenschäden zu verringern und/oder zu verhindern:

### Algemene veiligheidsvoorschriften

Bij het gebruik van elektrische apparaten moeten noodzakelijke voorzorgsmaatregelen altijd worden opgevolgd, om het risico op brand, elektrische schokken en persoonlijk letsel te verminderen en/of te voorkomen.

- Volg de installatiestappen zoals beschreven in deze handleiding.
- Lees de algemene veiligheidsvoorschriften.
- Laat installatie, onderhoud en reparaties over aan een gekwalificeerde serviceverlener; gevaar van electrocutie!
- Opgelet: om het risico op elektrische schokken te beperken, mag u het gloedbed niet verwijderen.
- Indien het toestel is beschadigd, neem dan eerst contact op met de leverancier.
- Plaats de haard niet buitenshuis.
- Indien de haard is ingeschakeld, dient de omgevingstemperatuur van de ruimte waarin de haard staat opgesteld tussen de 5 en 30 graden Celsius te zijn.
- Omgevingstemperatuur tijdens opslag en transport dient tussen de 20 en 60 graden Celsius te zijn.
- Plaats de haard niet in de directe omgeving van een bad, douche of zwembad. De relatieve luchtvochtigheid dient < 85% te zijn.
- Installeer de haard niet in toegestaan tot 2000m boven zeeniveau.
- Plaats de haard niet direct onder een wandcontactdoos of aansluitdoos.
- Indien er een storing optreedt, dient u de hoofdschakelaar aan de voorzijde op 0 (UIT) te zetten.
- Plaats het toestel niet op tapijt of vloerkleden.
- Om oververhitting van de haard te voorkomen mag deze niet worden afgedekt. Plaats geen materiaal voor of tegen het apparaat en in het bijzonder belemmer de luchtcirculatie rondom het apparaat niet.
- Bij oververhitting van materialen ontstaat dan het risico op brand.
- Wanneer de voedingskabel is beschadigd, dient deze vervangen te worden.

### Aanvullende algemene veiligheidsvoorschriften bij optie Atmos Heating

Meubels, gordijnen en andere brandbare materialen dienen minimaal op 1 meter afstand van de haard te worden geplaatst.

### General safety regulations

When using electrical appliances, necessary precautions must always be taken to reduce and/or prevent the risk of fire, electric shock, and personal injury:

- Follow the installation steps described in this manual.
- Read the general safety regulations.
- Leave installation, maintenance and repairs to a qualified service provider; danger of electrocution!
- Caution: to reduce the risk of electric shock, do not remove the ember bed.
- The unit contains no user-serviceable parts, except cleaning of the glass reflector and front window.
- If the unit is damaged, contact the supplier first.
- Do not use the fireplace outdoors.
- If the fire is switched on, the ambient temperature of the room in which the fire is placed must be between 5 and 30 degrees Celsius.
- Ambient temperature during storage and transport should be between -20 and 60 degrees Celsius.
- Do not use the fireplace in the immediate vicinity of a bath, shower, or swimming pool. The relative humidity must be < 85%.
- Installation and use is permitted up to 2000m above sea level.
- Do not place the fireplace directly under a wall socket or junction box.
- If a malfunction occurs, set the main switch on the front panel to 0 (OFF).
- Do not place the unit on carpet or rugs.
- To prevent overheating of the fireplace, it must not be covered. Do not place any material in front of or against the unit and, in particular, do not obstruct the air circulation around the unit. When materials overheat, there is a risk of fire.
- If the power lead becomes damaged, it must be replaced by the supplier or another qualified service provider to avoid danger.

### Additional general safety regulations for Atmos Heating option

Furniture, curtains, and other combustible materials must be placed at least one metre away from the fireplace.

### Consignes générales de sécurité

Lors de l'utilisation d'appareils électriques, les précautions nécessaires doivent toujours être prises pour réduire et/ou prévenir les risques d'incendie, de choc électrique et de blessures, notamment:

- Suivez les étapes d'installation décrites dans ce manuel.
- Lisez les instructions générales de sécurité.
- Confiez l'installation, l'entretien et les réparations à un fournisseur de services qualifié: danger d'électrocution!
- Attention: pour réduire le risque de choc électrique, ne retirez pas le lit incandescent.
- Si l'appareil est endommagé, contactez d'abord le fournisseur.
- N'utilisez pas le foyer à l'extérieur.
- Si le foyer est allumé, la température ambiante de la pièce dans laquelle il est placé doit être comprise entre 5 et 30 degrés Celsius.
- La température ambiante pendant le stockage et le transport doit être comprise entre -20 et 60 degrés Celsius.
- N'utilisez pas le foyer à proximité immédiate d'une baignoire, d'une douche ou d'une piscine. L'humidité relative doit être inférieure à 85%.
- L'installation et l'utilisation est autorisée jusqu'à 2000 m au-dessus du niveau de la mer.
- Ne placez pas le foyer directement sous une prise murale ou une boîte de jonction.
- En cas de dysfonctionnement, désactivez l'interrupteur principal à l'avant.
- Ne placez pas l'unité sur un tapis ou de la moquette.
- Pour éviter que le foyer surchauffe, il ne doit pas être couvert. Ne placez aucun matériau devant ou contre l'appareil, et en particulier, n'obstruez pas la circulation de l'air autour de l'appareil. Il existe alors un risque d'incendie en cas de surchauffe des matériaux.
- Si le câble d'alimentation est endommagé, il doit être remplacé par le fournisseur ou par un autre prestataire de services qualifié afin d'éviter tout danger.

### Consignes générales de sécurité supplémentaires pour l'option Atmos Heating

Les meubles, rideaux et autres matériaux inflammables doivent être placés à au moins 1 mètre du foyer.

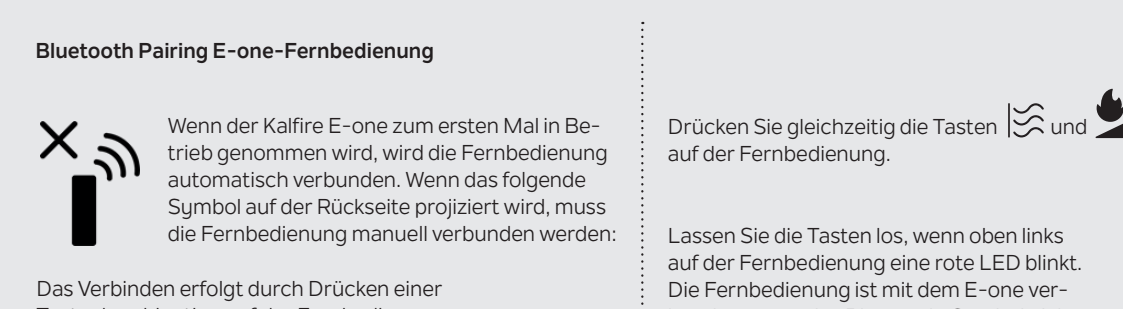
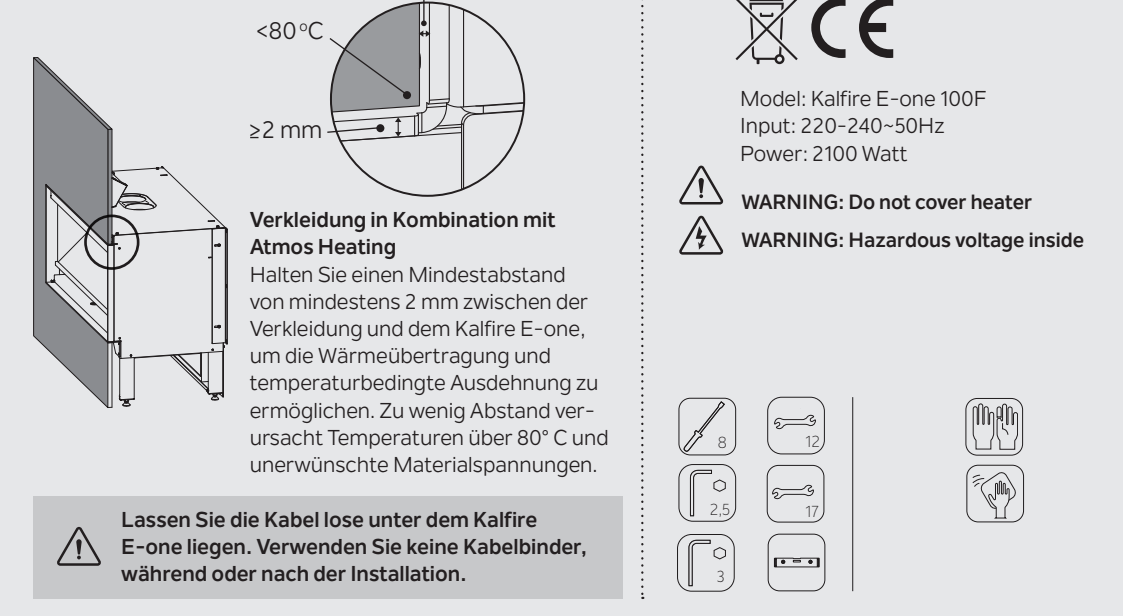
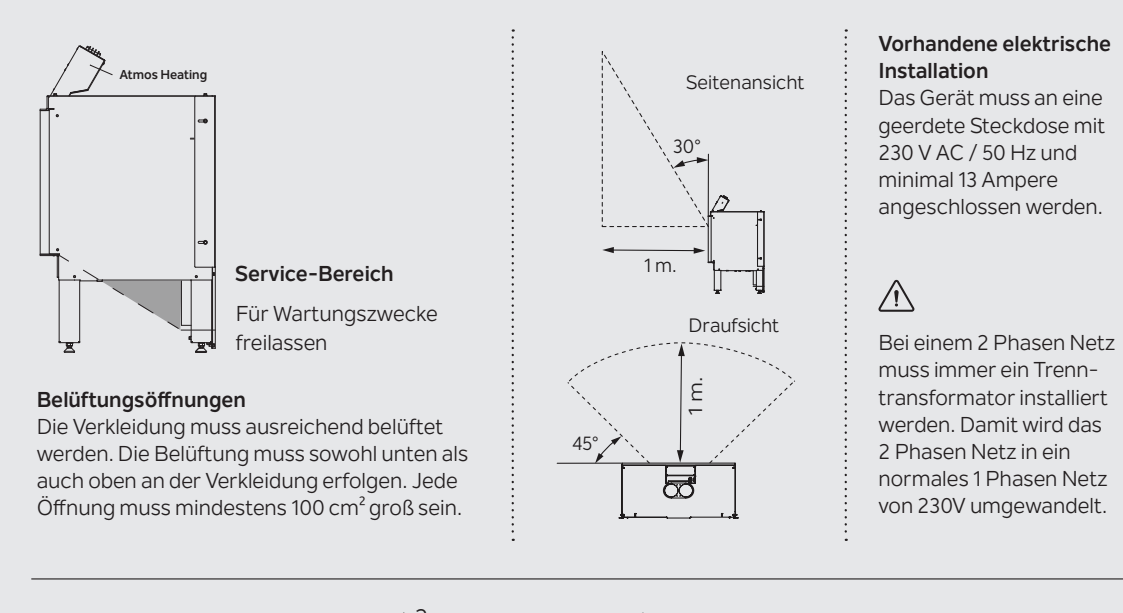
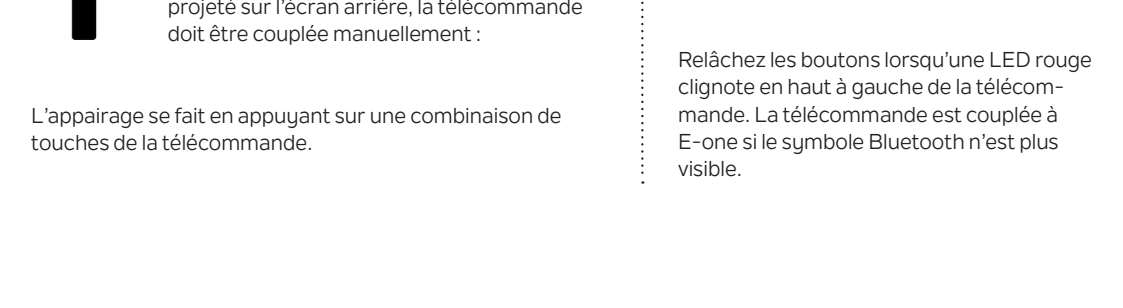
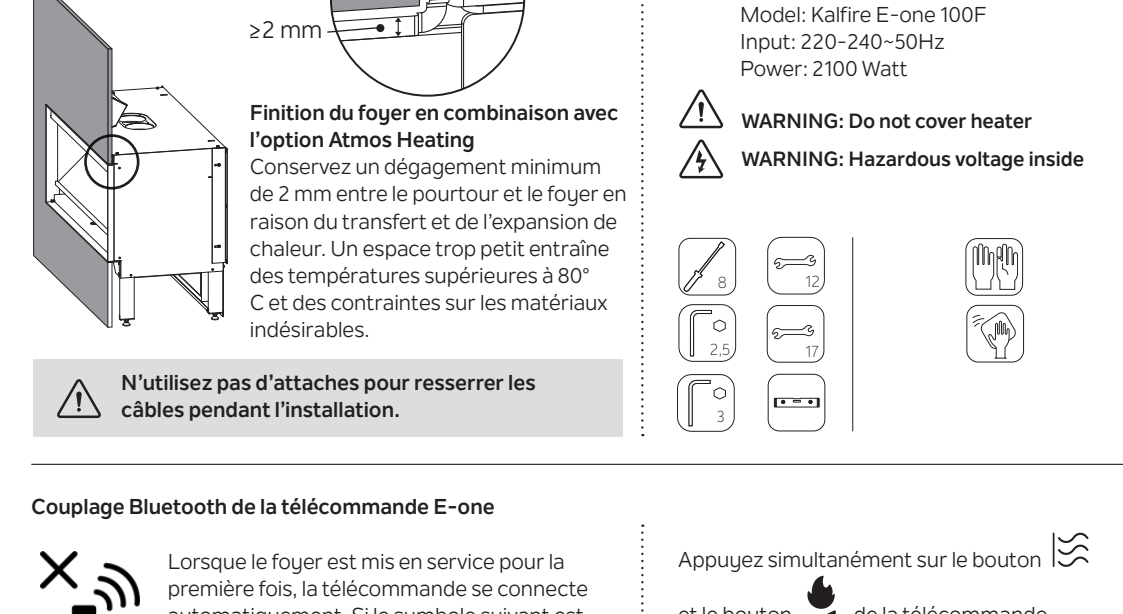
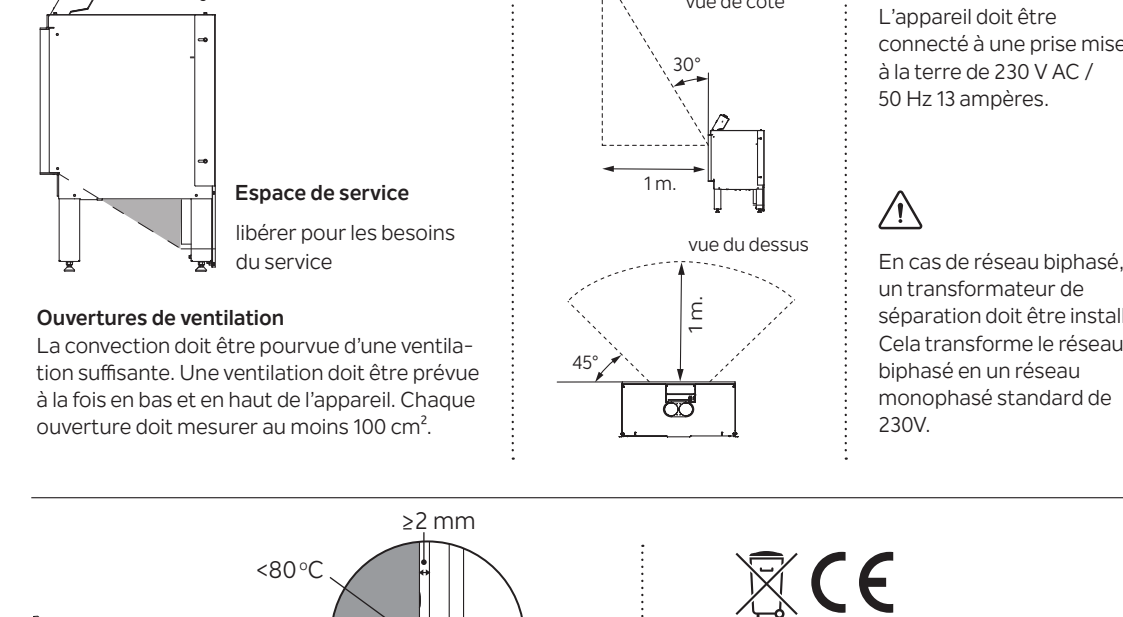
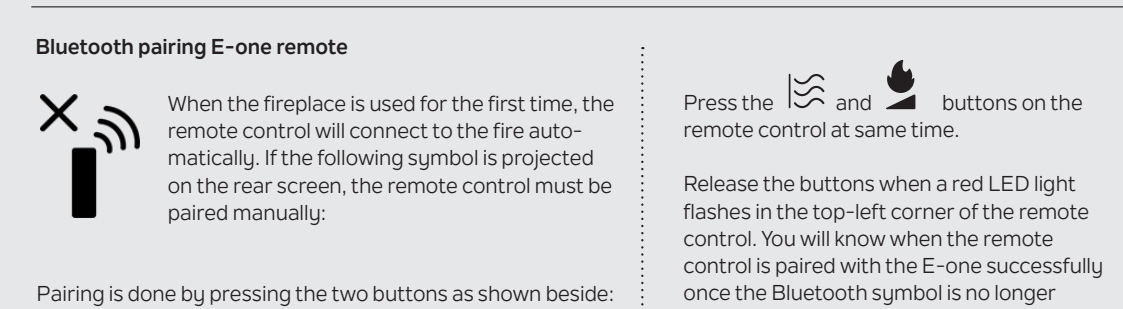
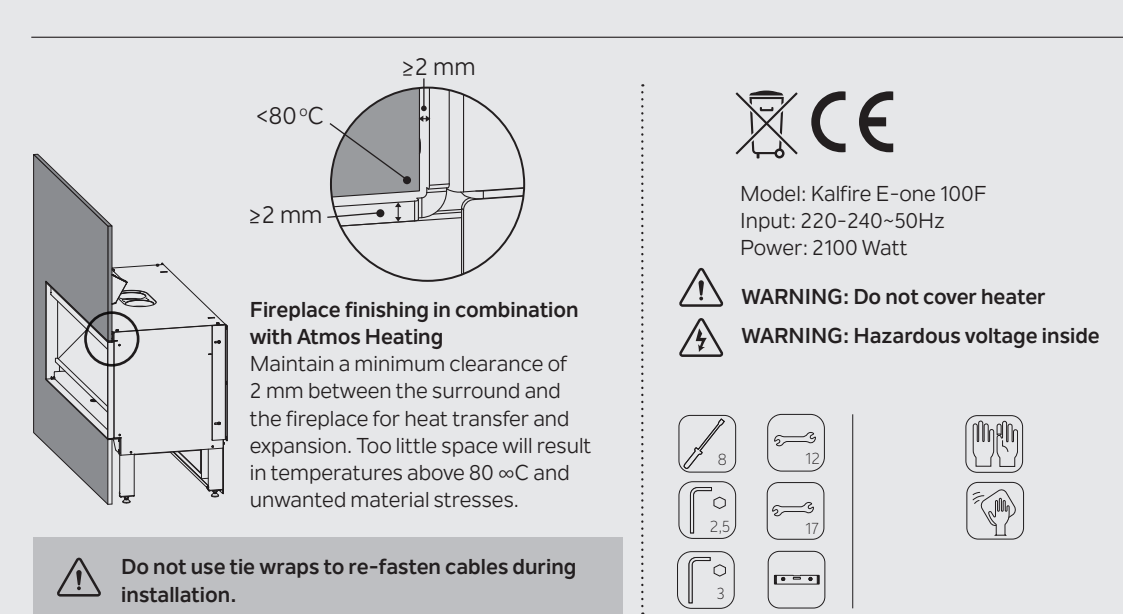
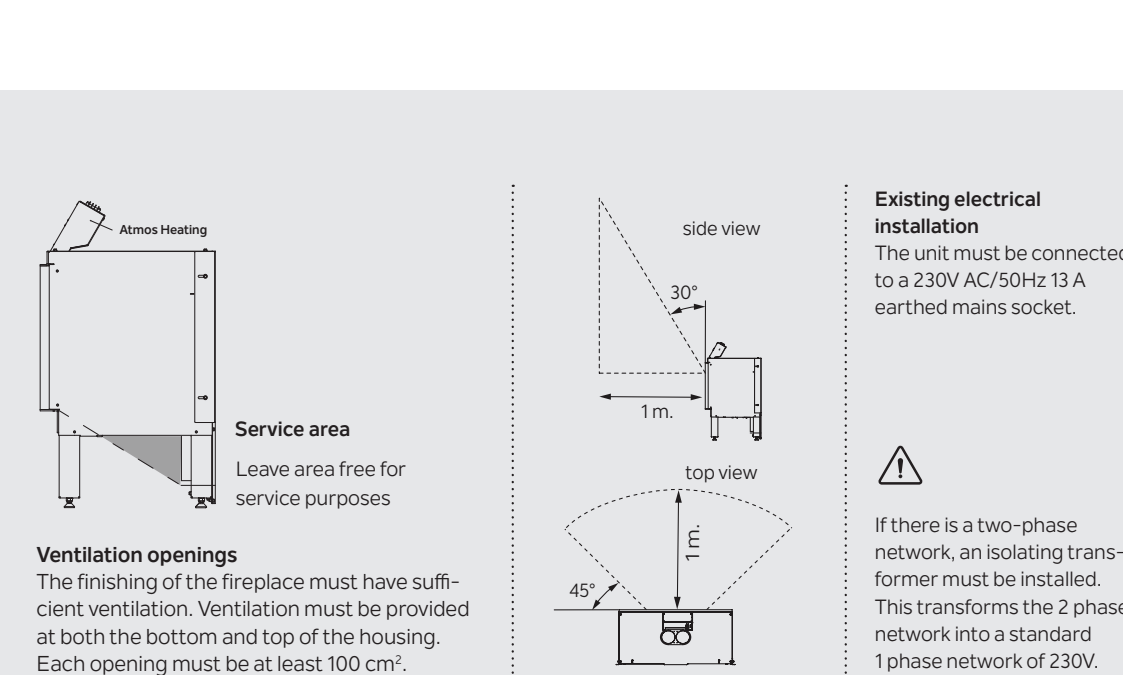
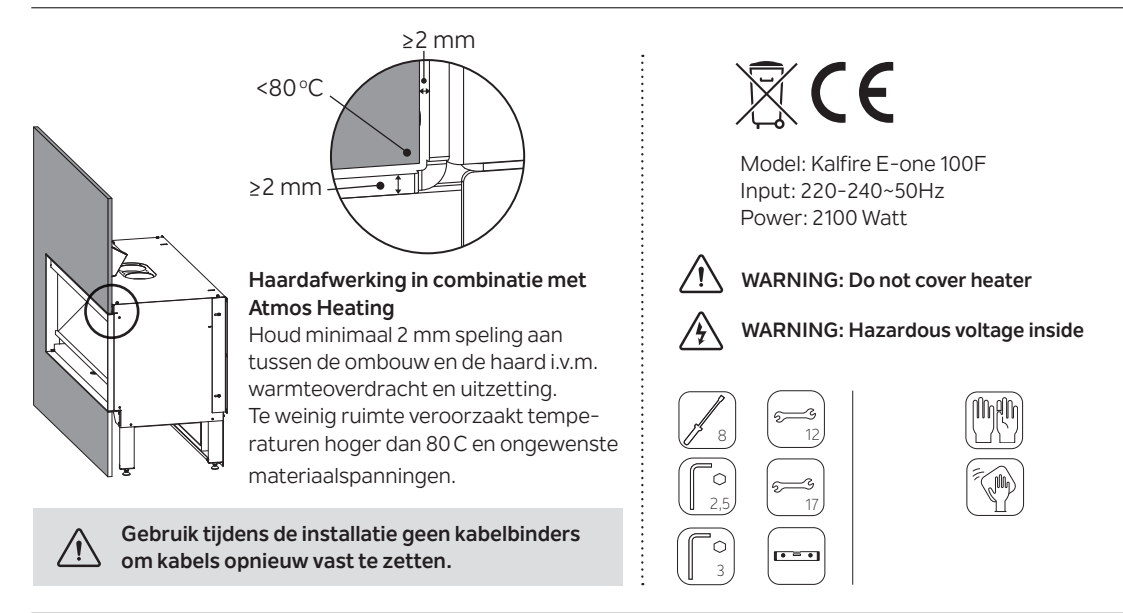
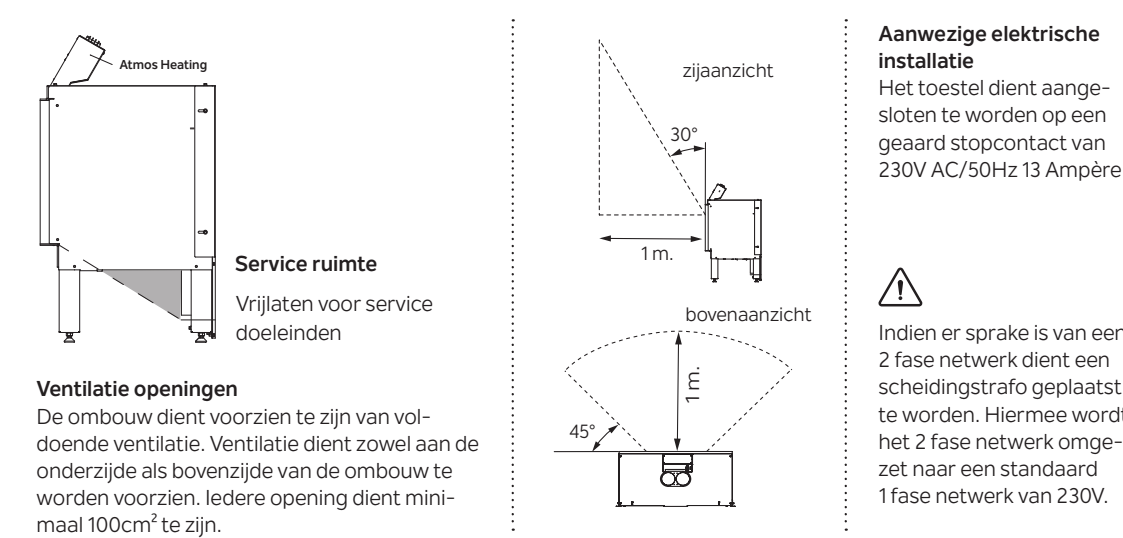

# Kalfire E-one 130F

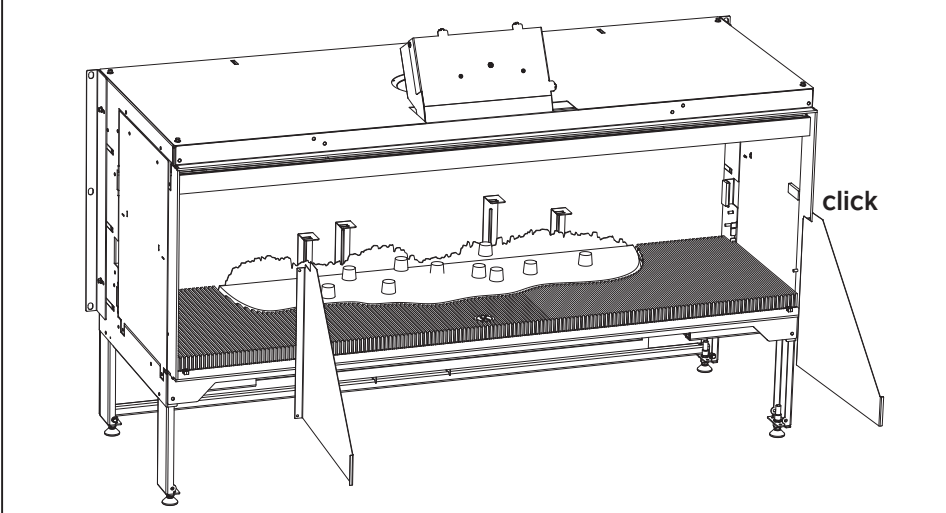
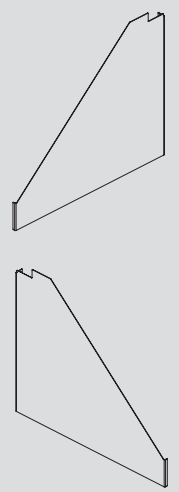
11.  

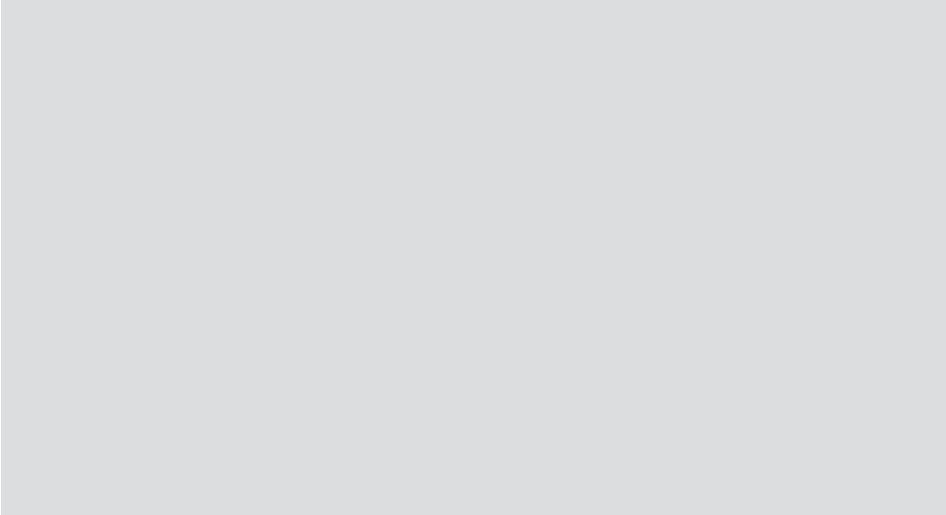
12. 

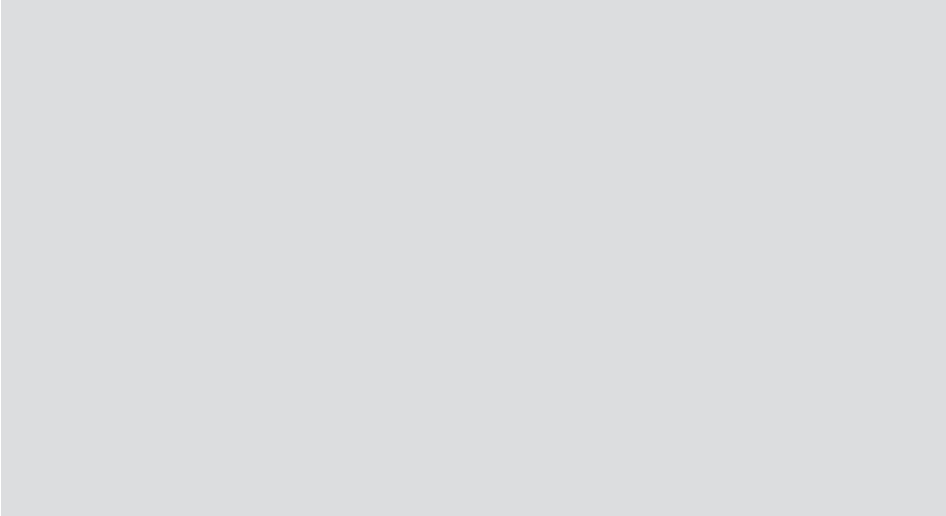
13. 

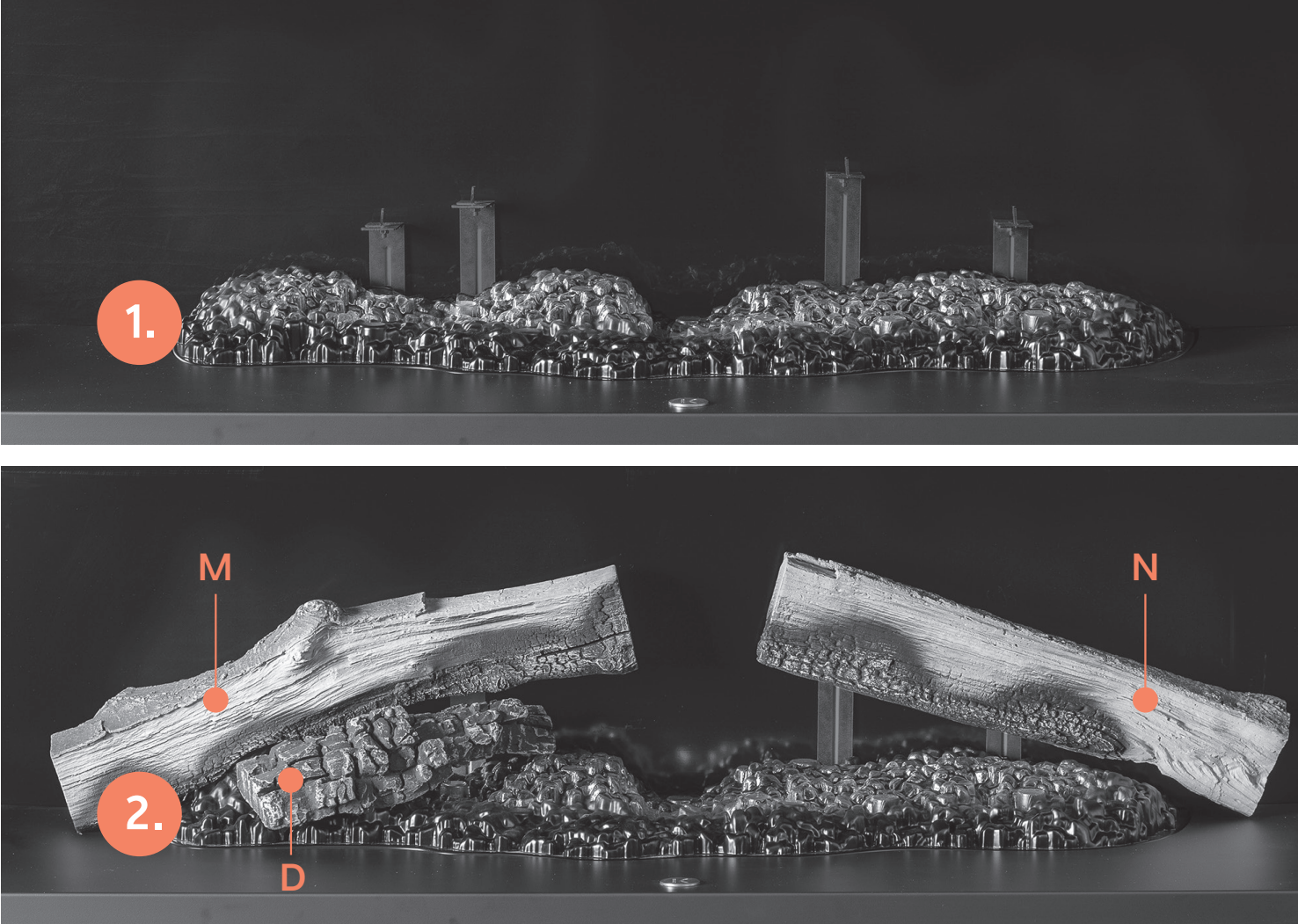
14. 

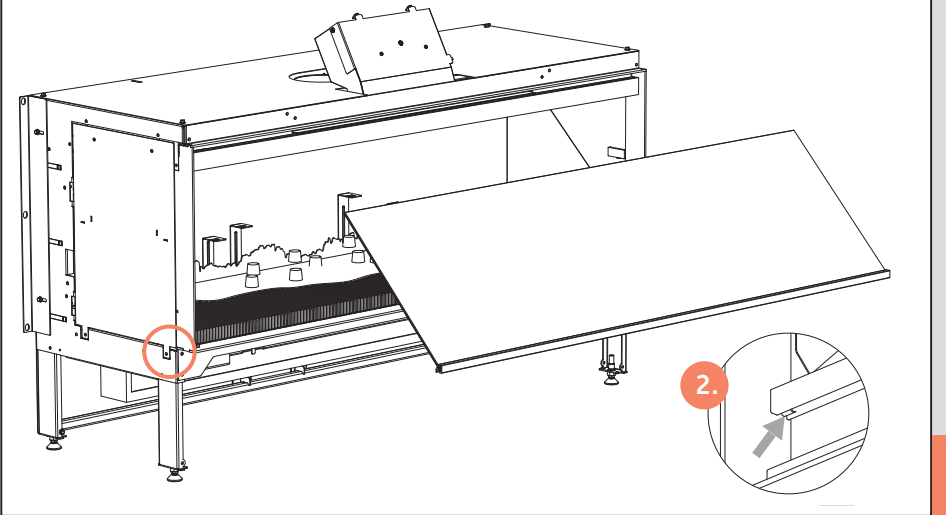
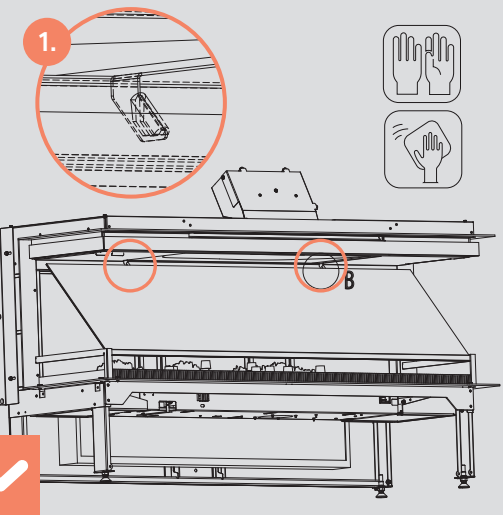

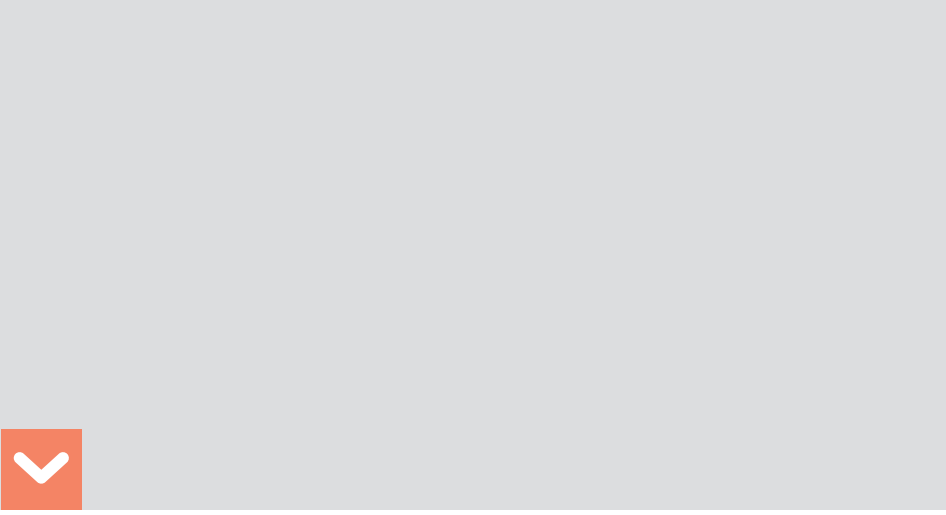
15.  

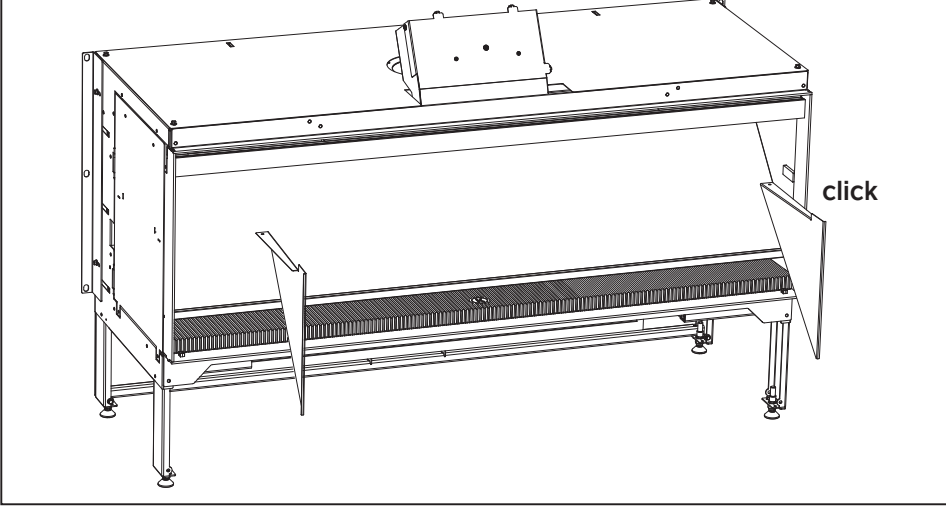
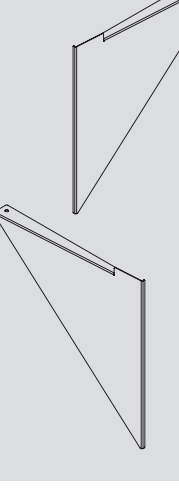
16. 

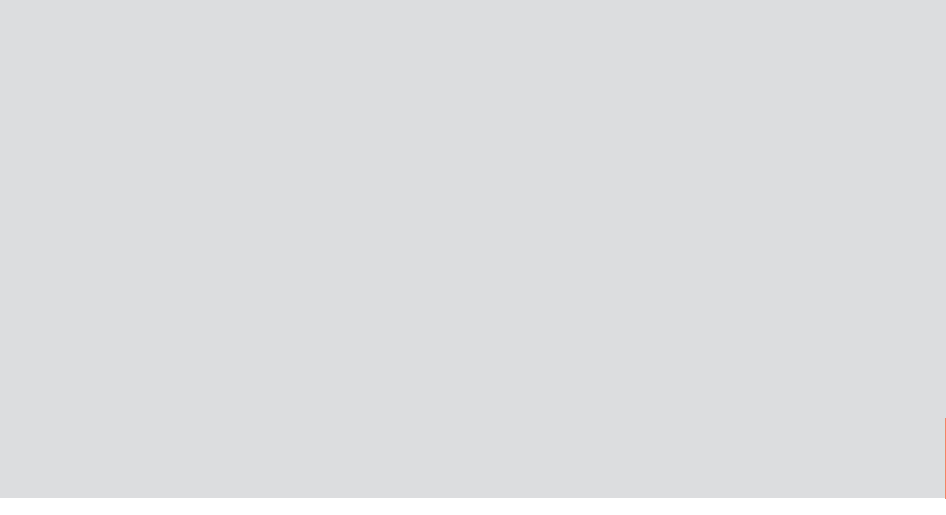
17.  

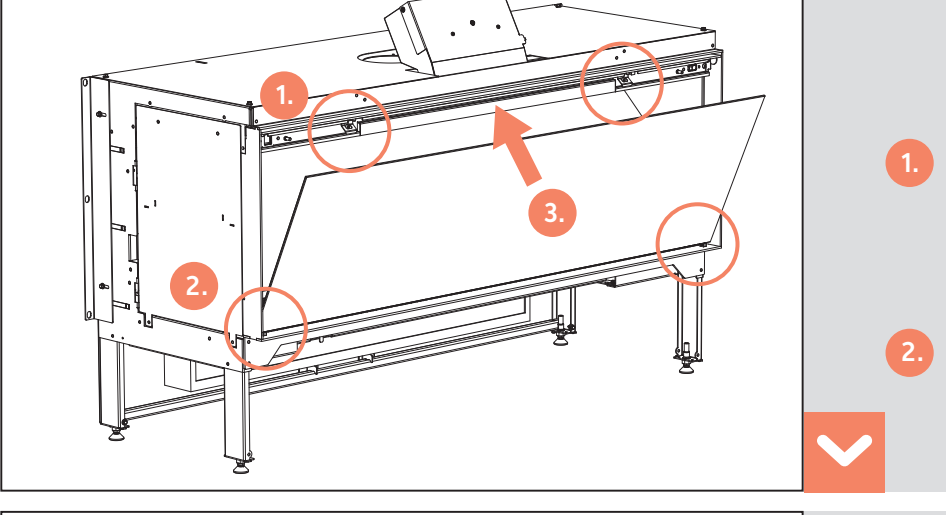
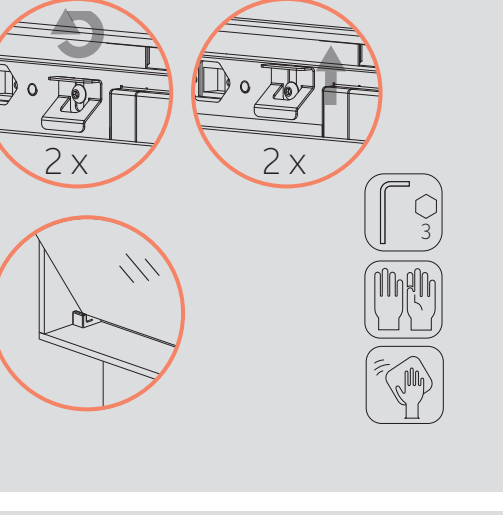
18. 

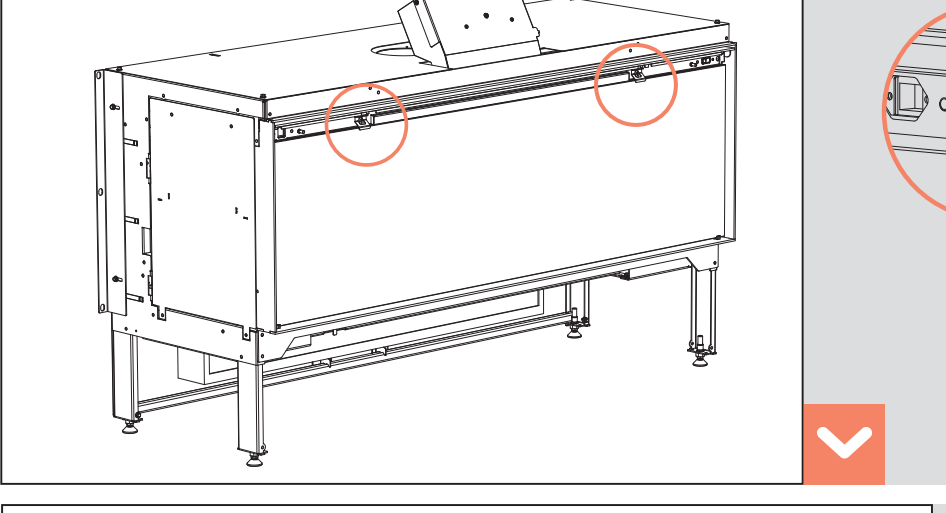

19.  

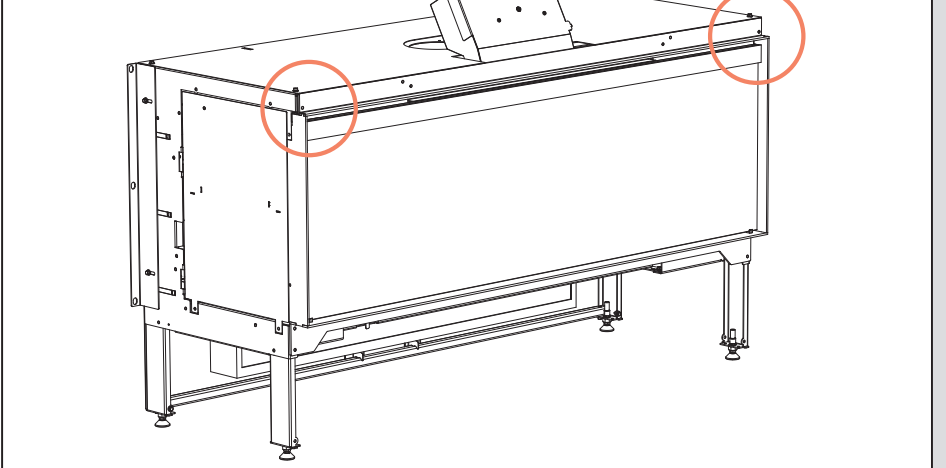
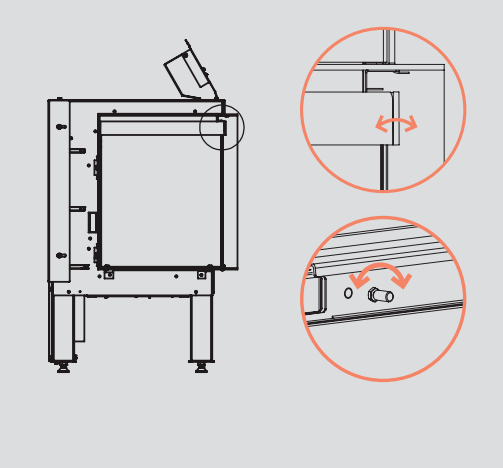
20.  

21.  

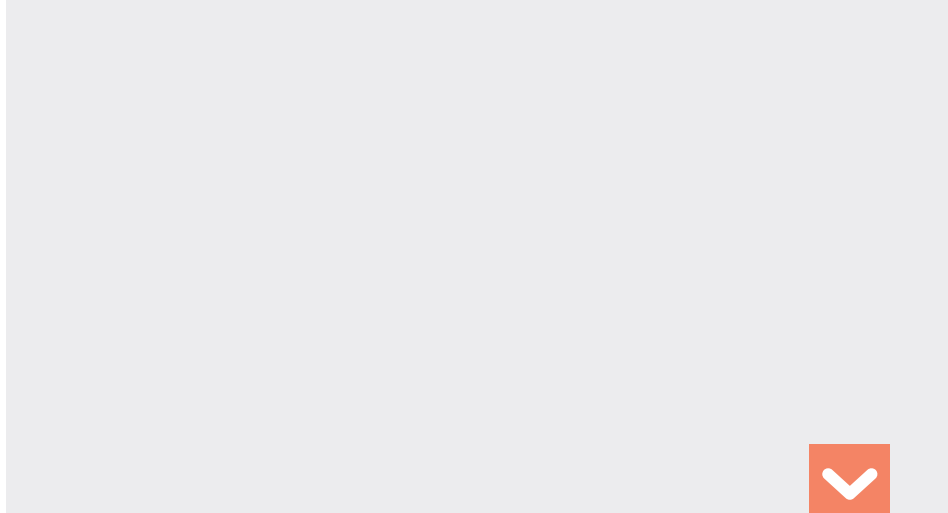
# Kalfire E-one 130S

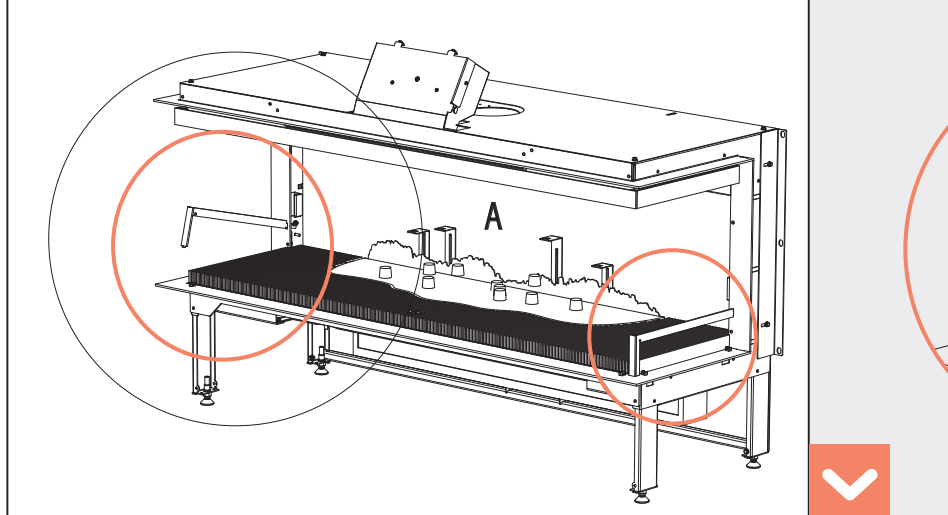
11. 

12.  

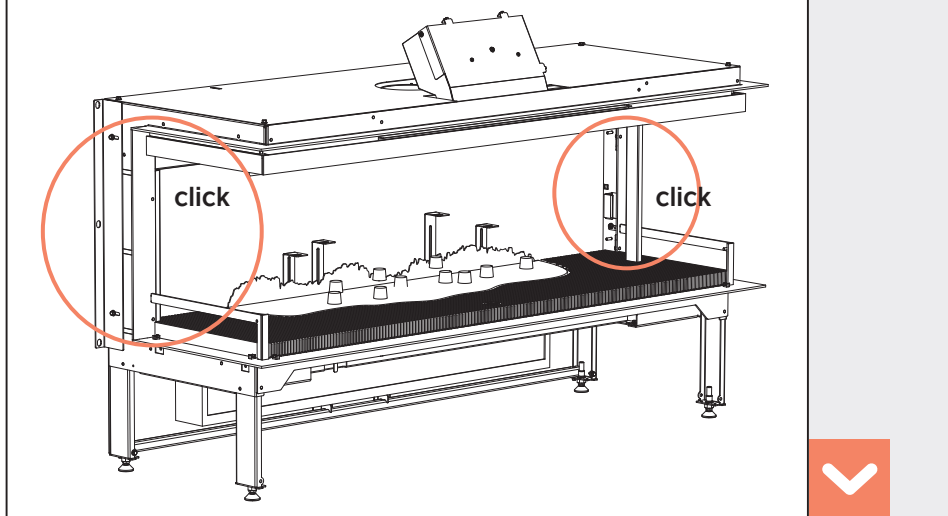
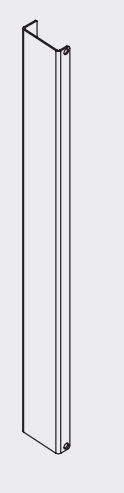
13.  

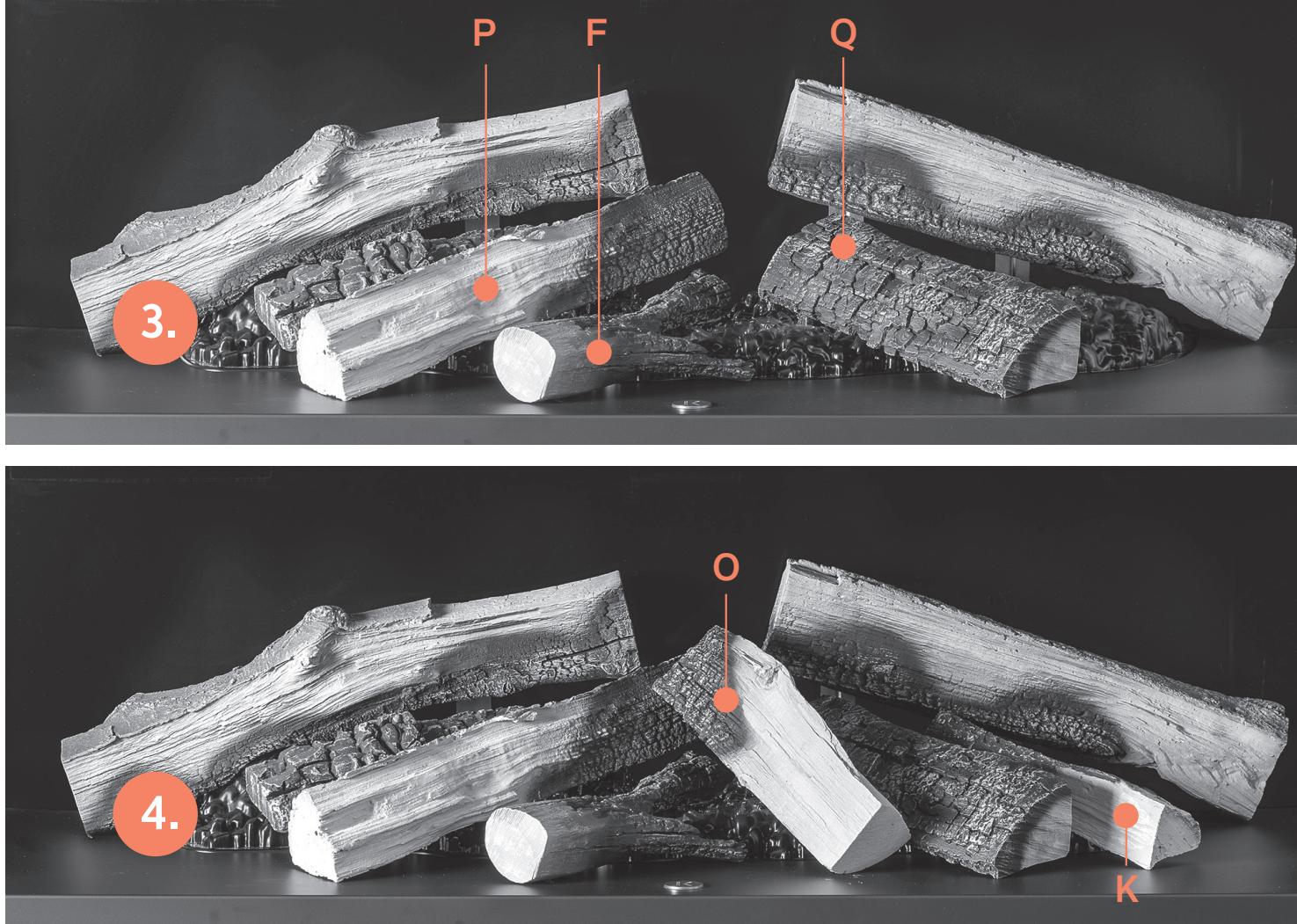
14. 

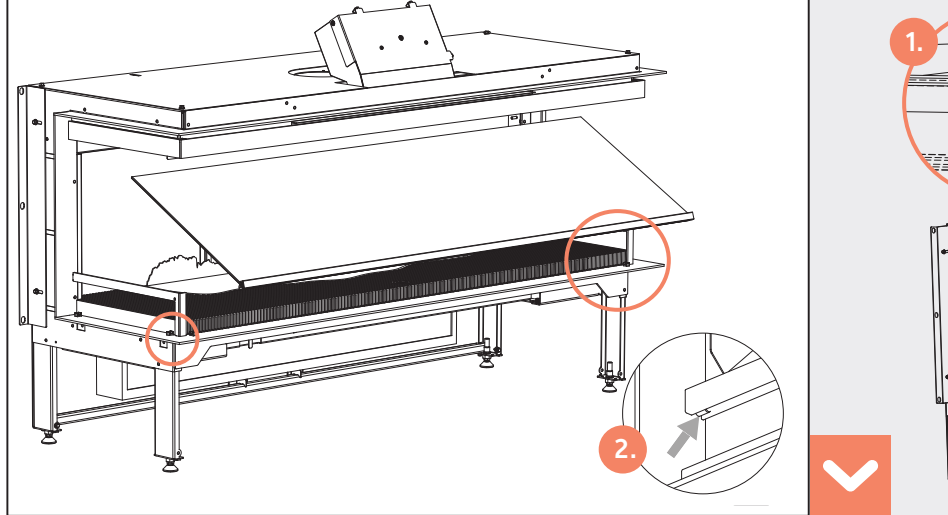
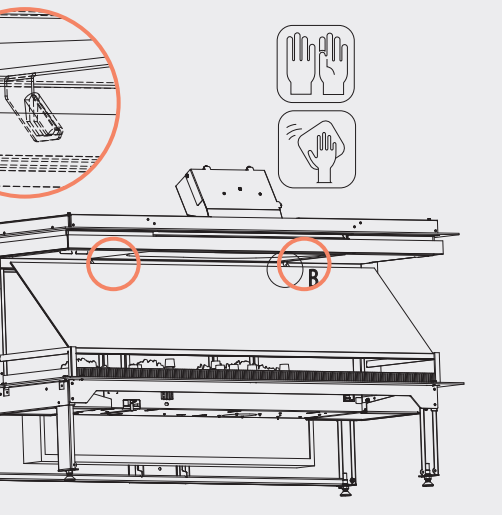
15.  

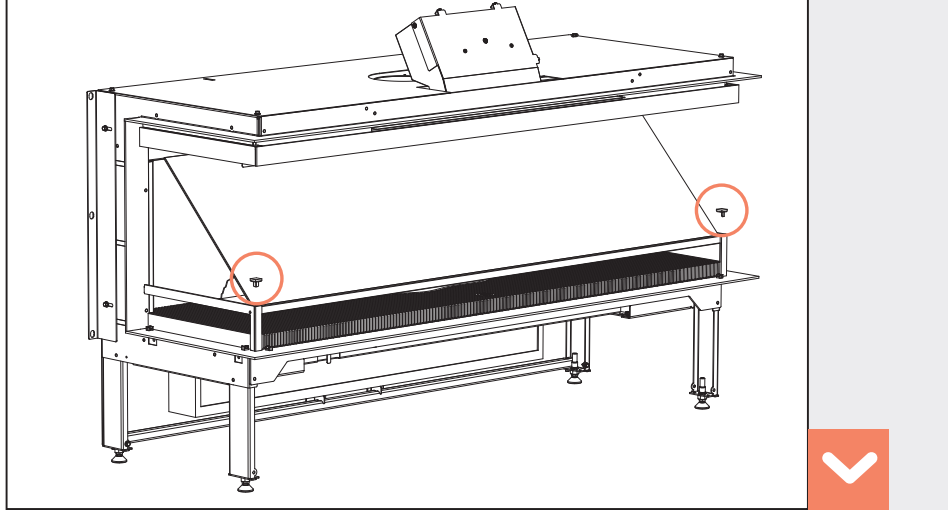
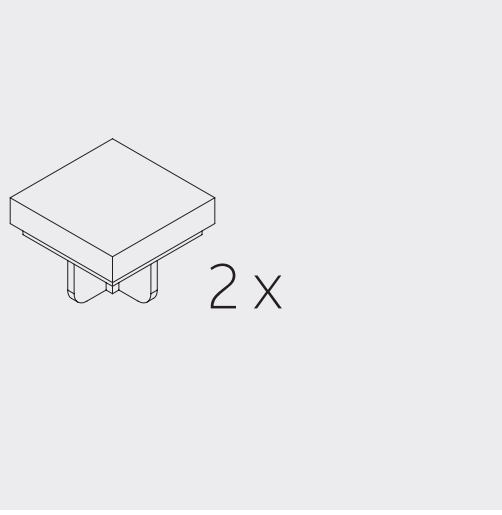
16.  

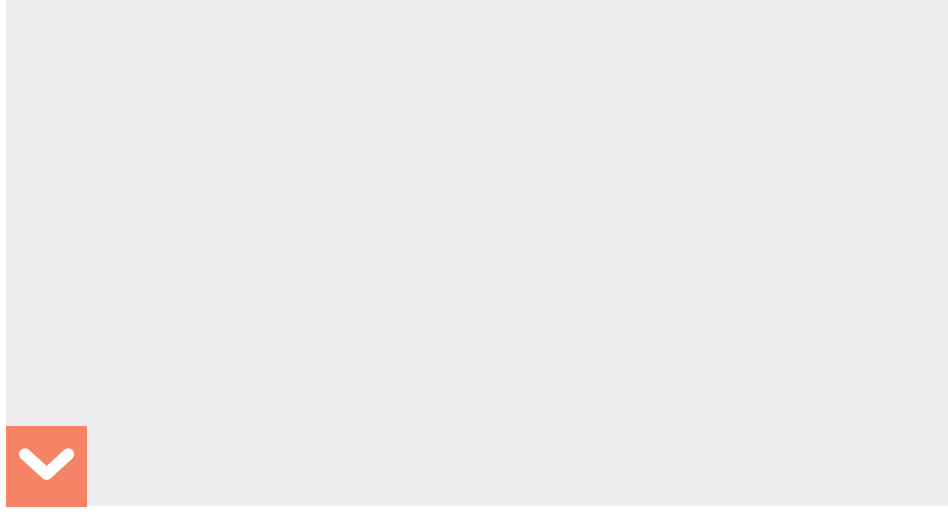
17. 

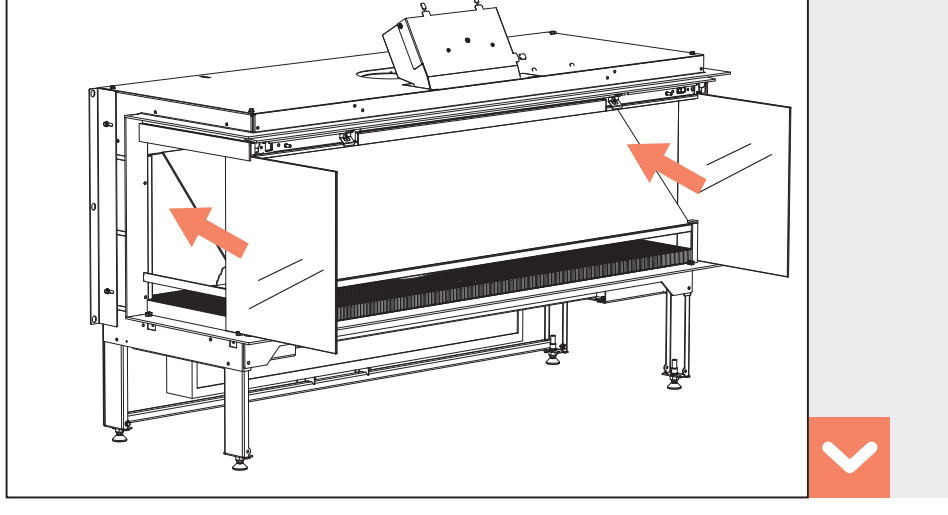
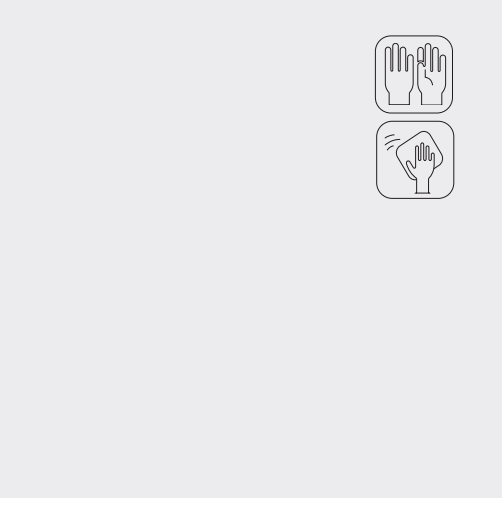
18.  

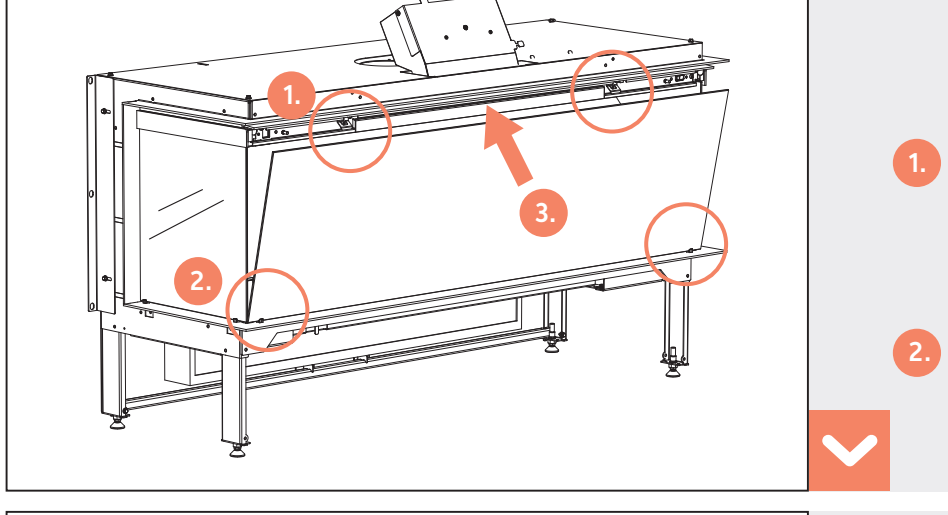
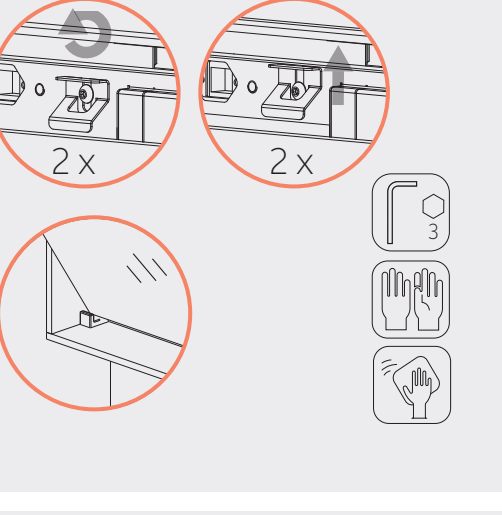
19.  

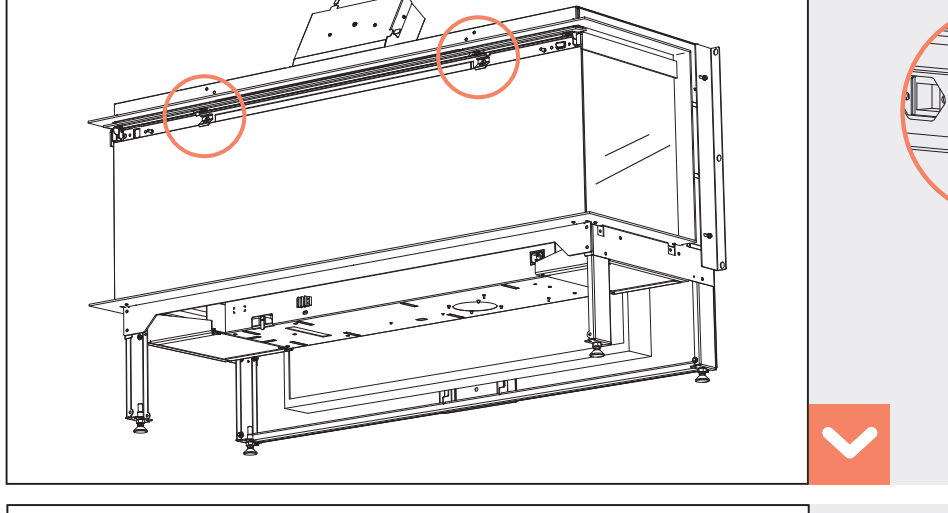
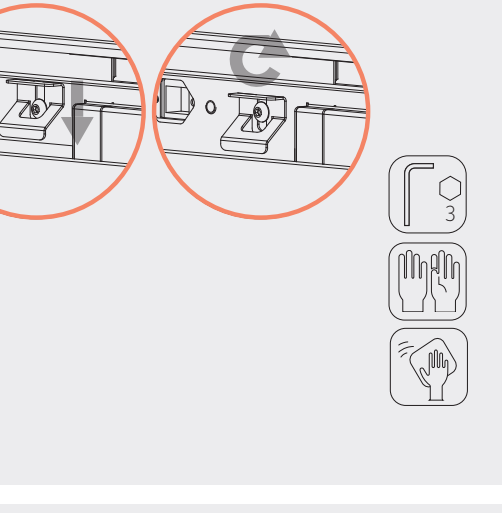

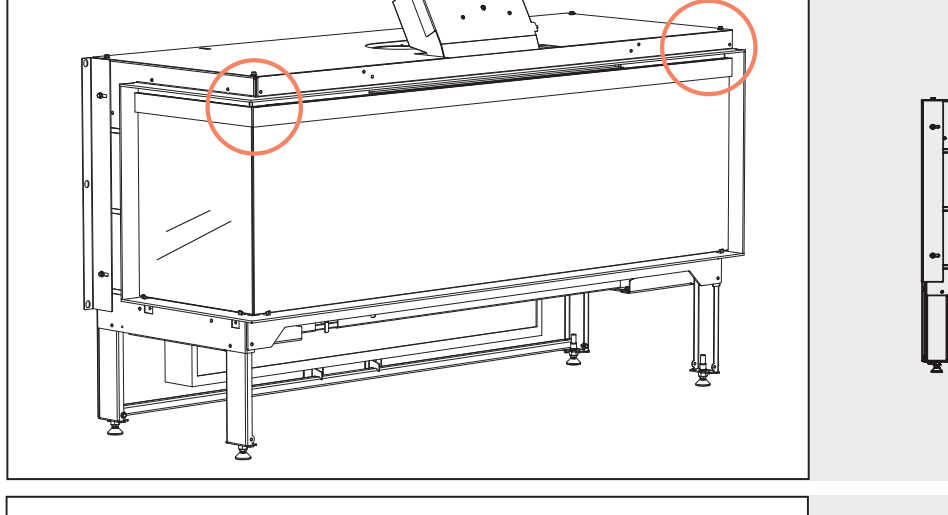
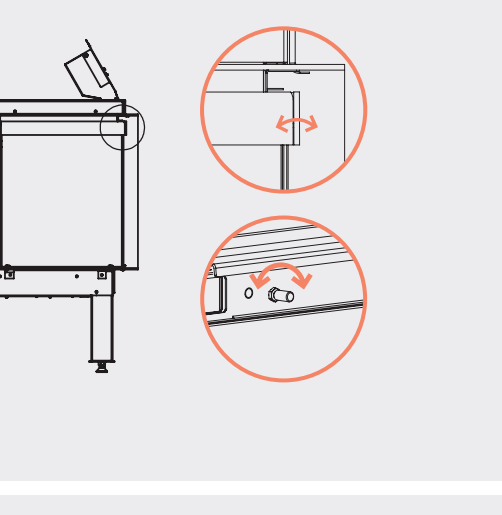
20.  

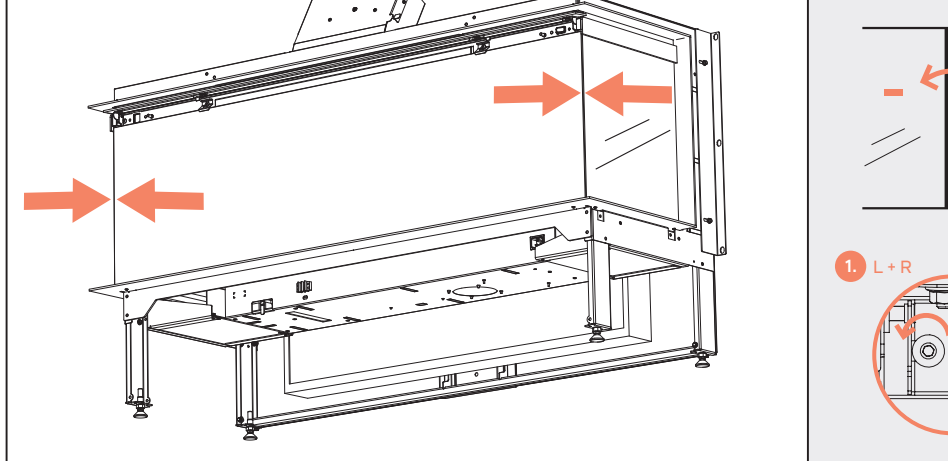
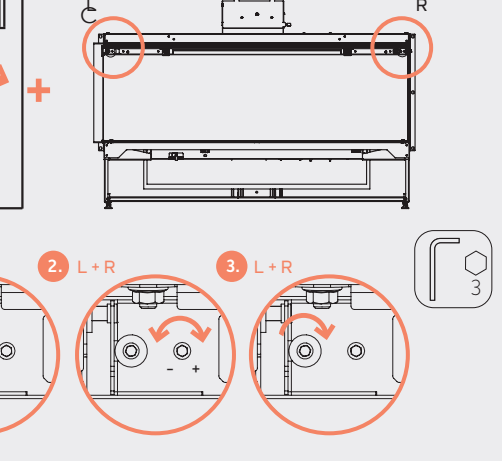

21.  

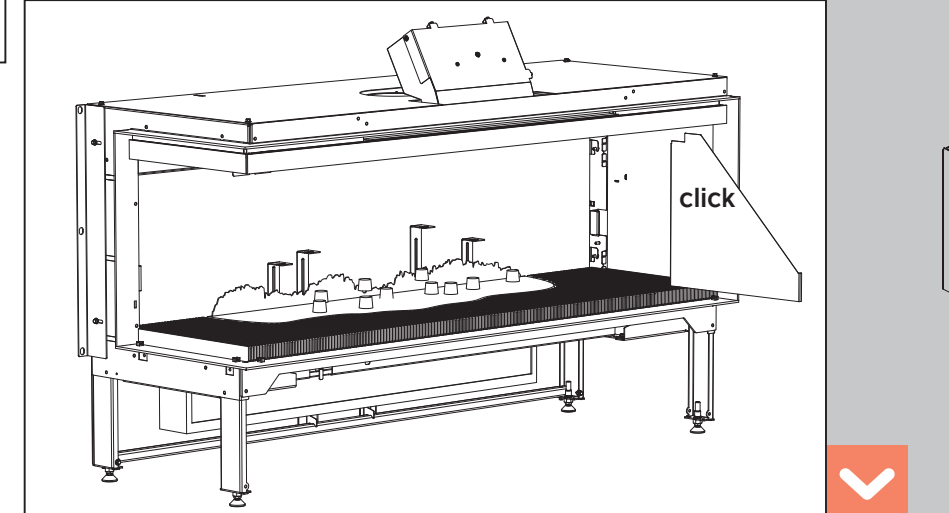
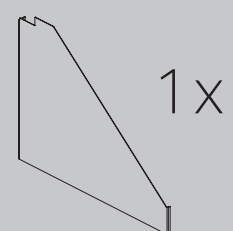
22.  

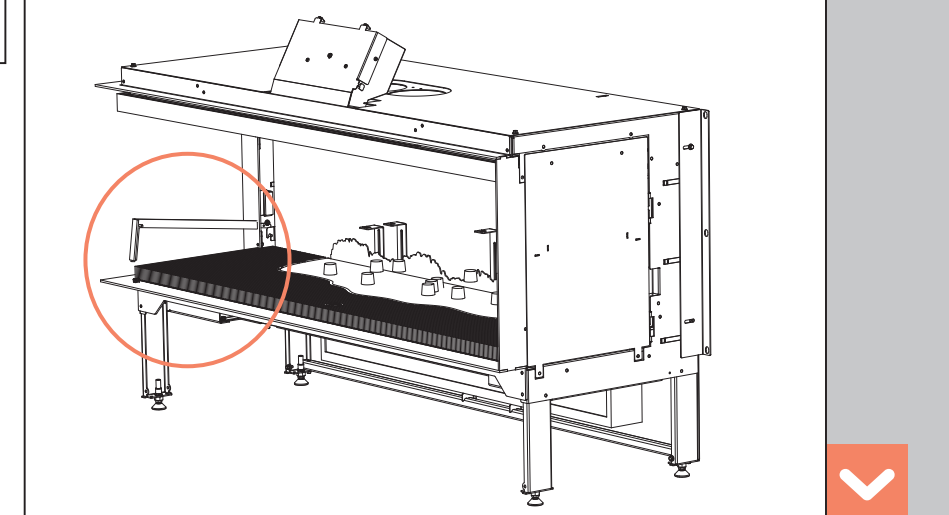
# Kalfire E-one 130CL Kalfire E-one 130CR

11.  

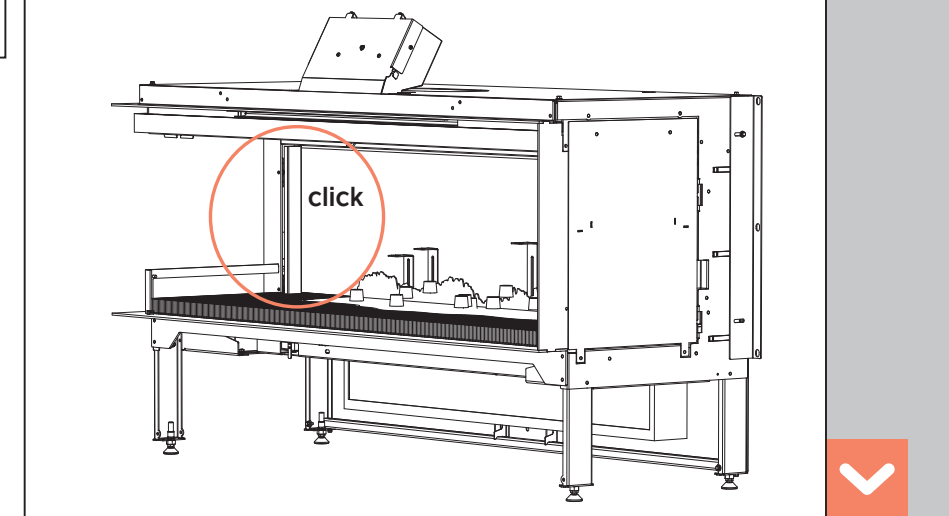
12.  

13.  

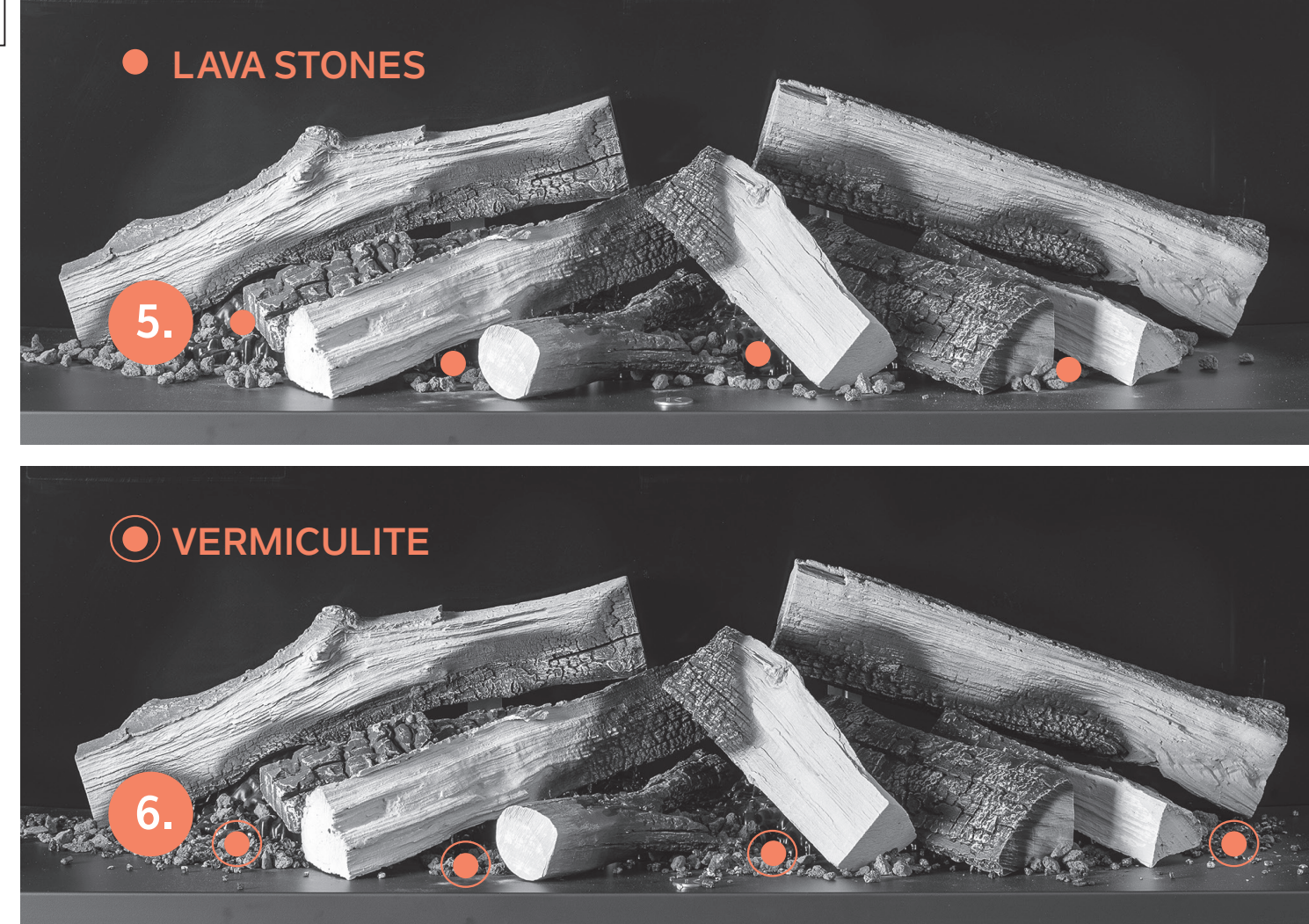
14. 

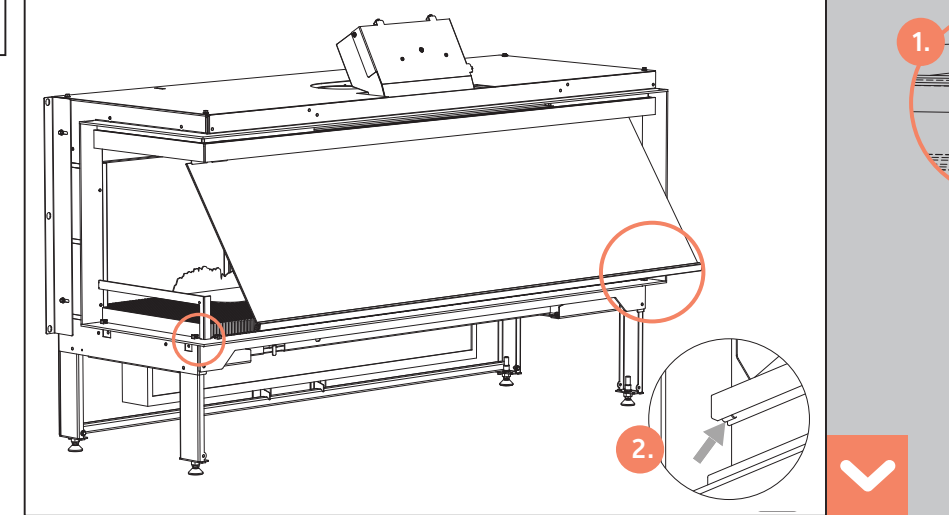
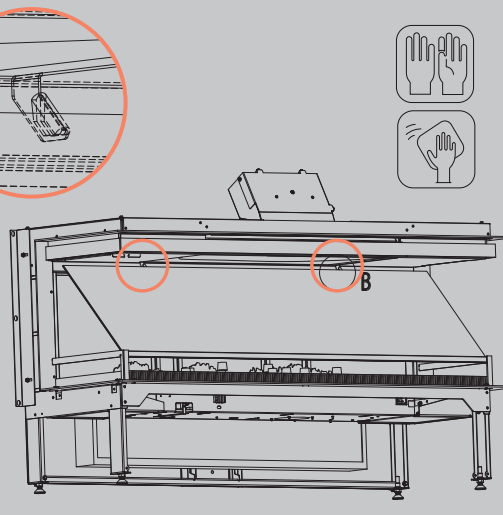
15.  

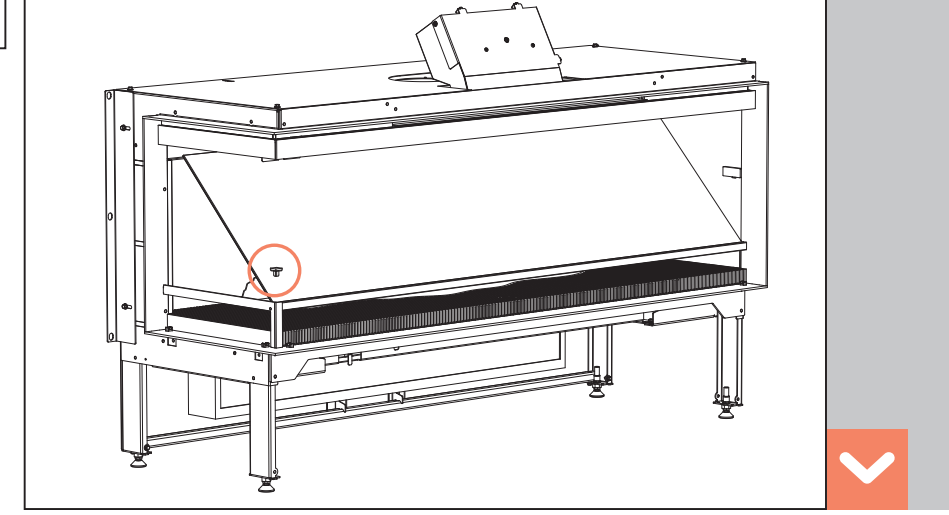
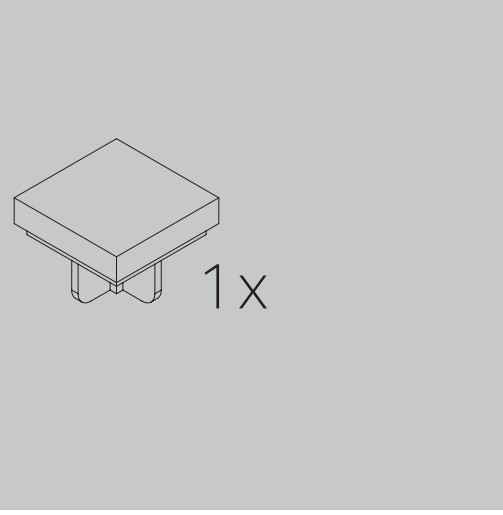
16.  

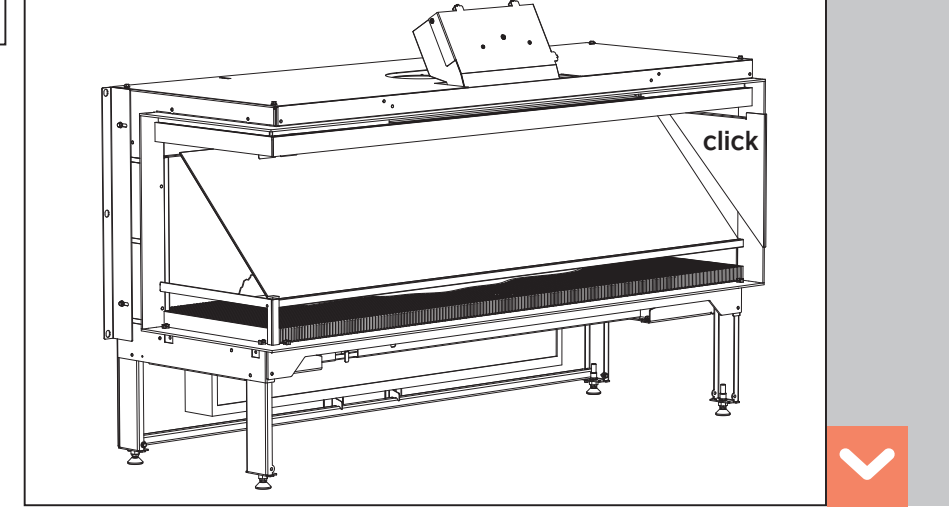
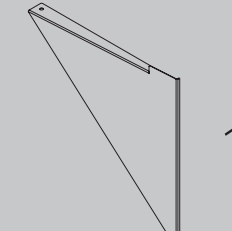
17.  

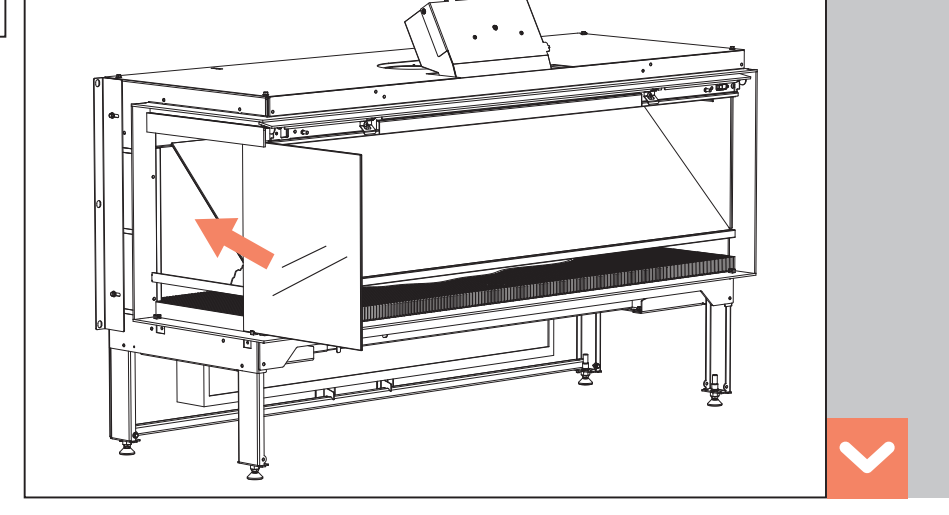
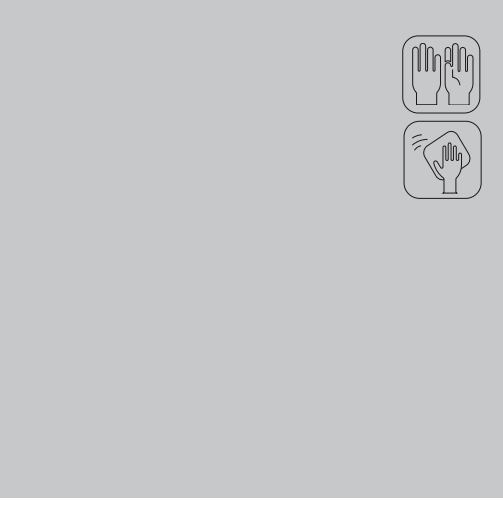
18.  

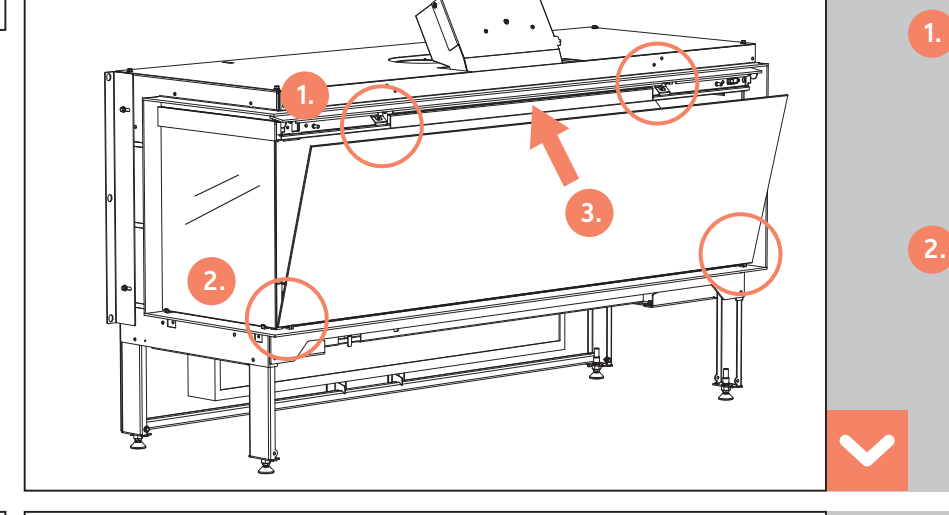
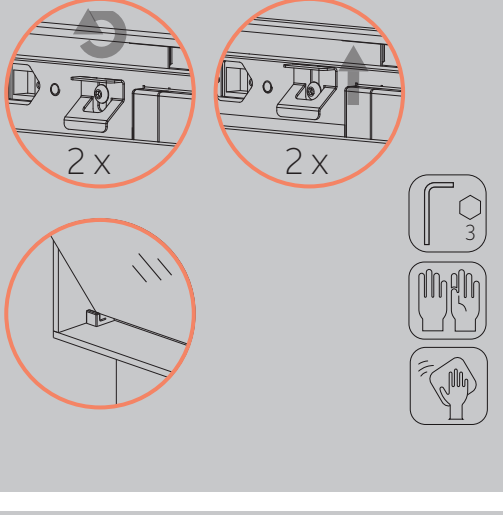
19.  

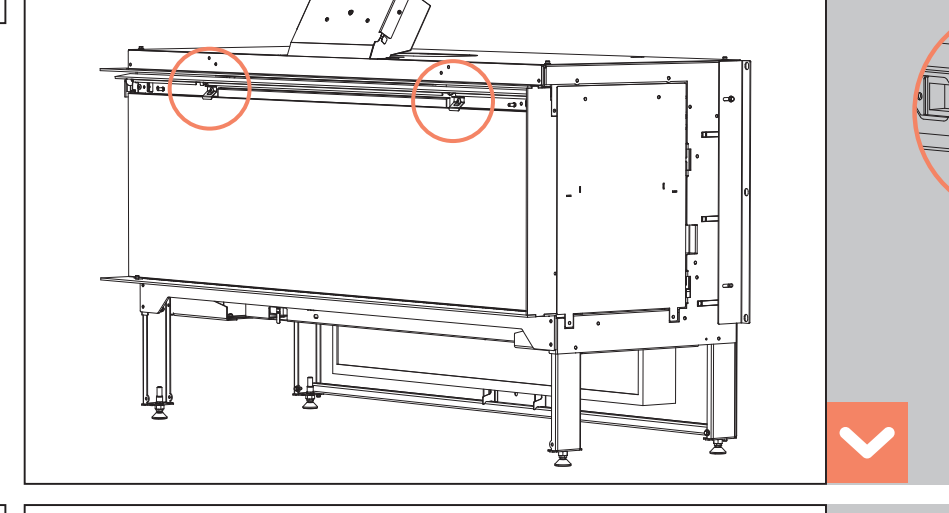
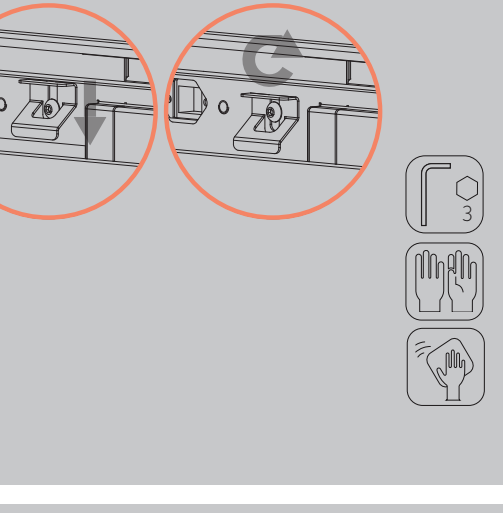
20.  

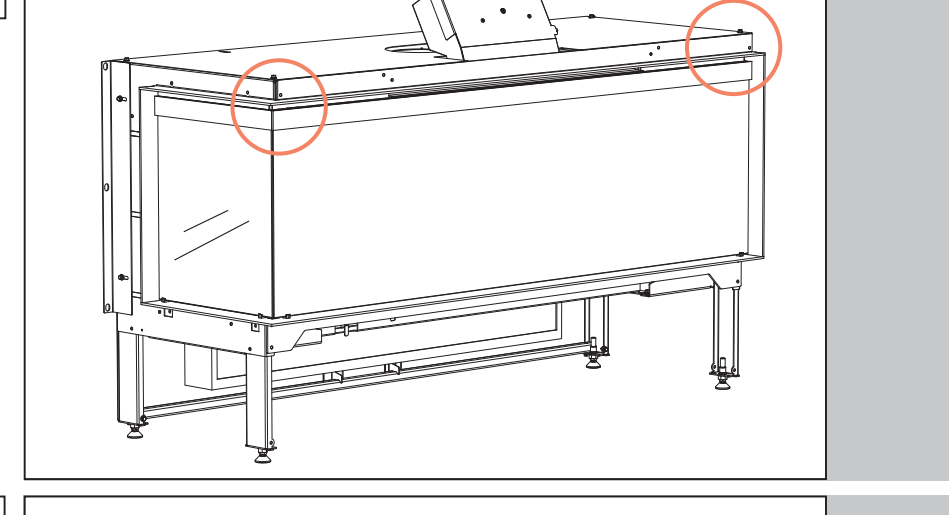
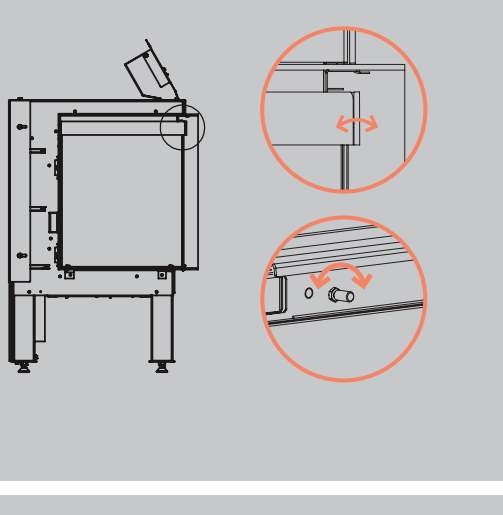
21.  

22. 