

# 805320A1 TRIM SENDER AND TRIM LIMIT SWITCH KIT

For Alpha and Bravo/Blackhawk Models

## NOTICE to INSTALLER

After Completing Installation, These Instructions Should Be Placed With The Product For The Owner's Future Use.

## Removal

### ⚠ WARNING

Always disconnect battery cables from battery before working around electrical system components to prevent injury to yourself or damage to electrical system.

1. Disconnect both battery cables from battery.
2. Remove stern drive unit.
3. Remove trim limit switch and trim position sender.

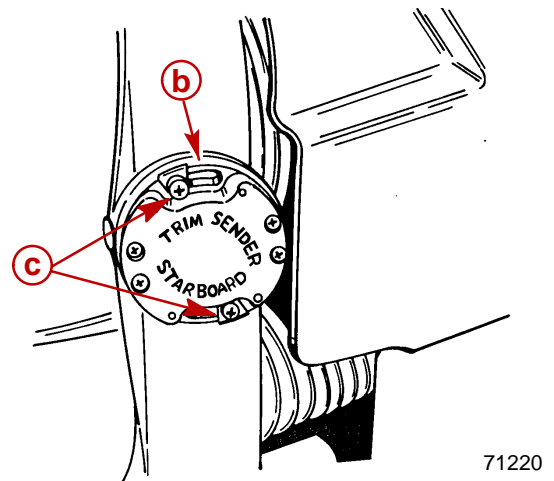
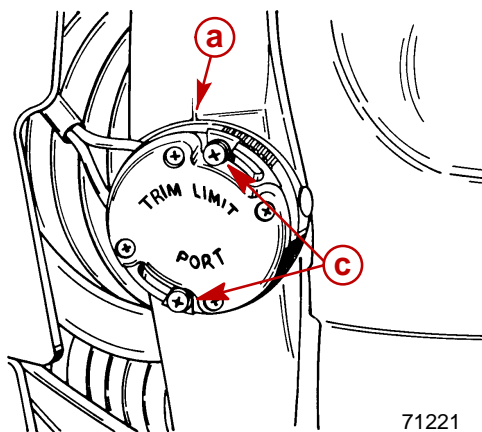

- a - Trim Limit Switch
- b - Trim Position Sender
- c - Screws, Washers and Retainers

4. **Earlier Alpha One Models** - Loosen front hose clamp on U-joint bellows. Remove bellows from flange.

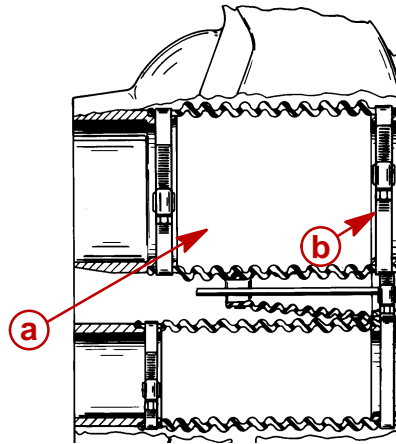

23158

- a - U-Joint Bellows
- b - Clamp

5. **Bravo/Blackhawk and Later Alpha One Models** - Remove U-joint bellows sleeve.

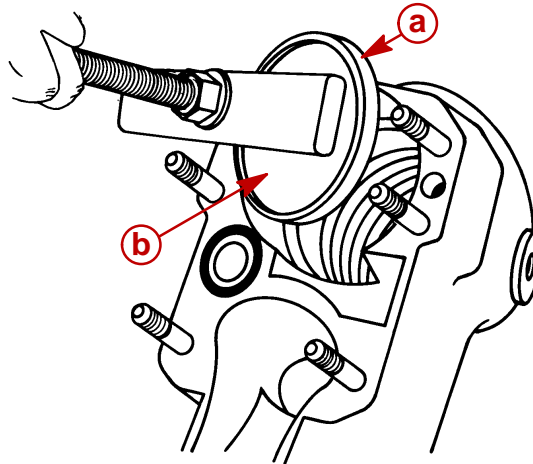

70179

- a - Sleeve
- b - Removal Tool (91-818169)

6. Remove both hinge pins.

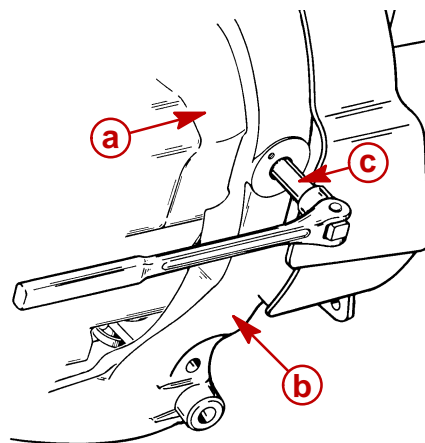

22113

- a - Bell Housing
- b - Gimbal Ring
- c - Hinge Pin Tool (91-78310)

- Pull back on bell housing and rotate it 90 degrees to gain access to the trim wire retainer bolt.

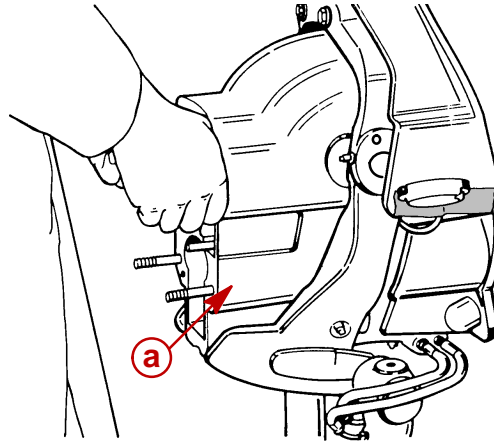

23363

**a** - Bell Housing

- Remove trim wire retainer.

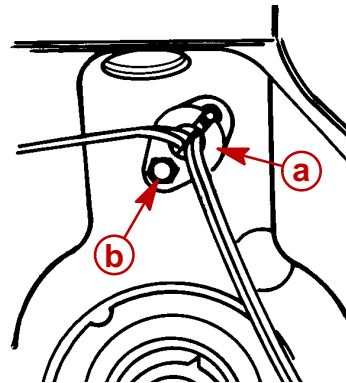

70197

**a** - Clamp  
**b** - Bolt

- Disconnect trim limit switch wires at the power trim pump. Also, disconnect trim sender wires at the engine harness.

## Installation

- Route new trim limit switch wires through hole. Bring together the two grommet halves and ensure they are seated tightly in the hole and that the flat edges that mate together are vertically aligned. Maintain light tension on the wires from inside the boat, to hold the grommets in the hole.

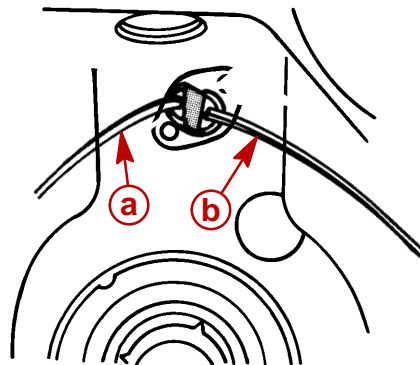

70198

**a** - Trim Limit Switch Wires  
**b** - Trim Position Sender Wires

2. Reinstall retainer and torque to 90-100 lb. in. (10.2 - 11.3 N-m).

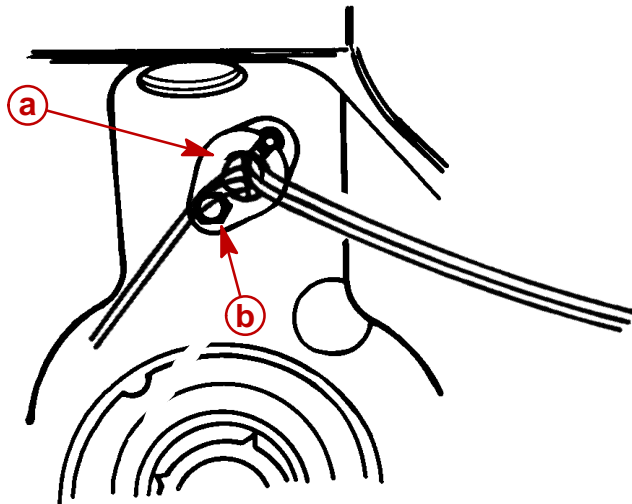

70197

- a - Clamp
- b - Bolt

3. **Earlier Alpha One Models** - Prepare U-joint bellows for installation as follows:
  - a. Clean gimbal housing mounting flange with sandpaper and wipe clean with lacquer thinner.

**⚠ WARNING**

**Be sure to read and follow package label directions when using bellows adhesive.**

- b. Apply bellows adhesive to mounting surface on inside of bellows.
  - c. Position grounding clip and hose clamp over bellows end.
4. Install bell housing between gimbal ring. Push on bell housing and guide U-joint bellows onto gimbal housing mounting flange.

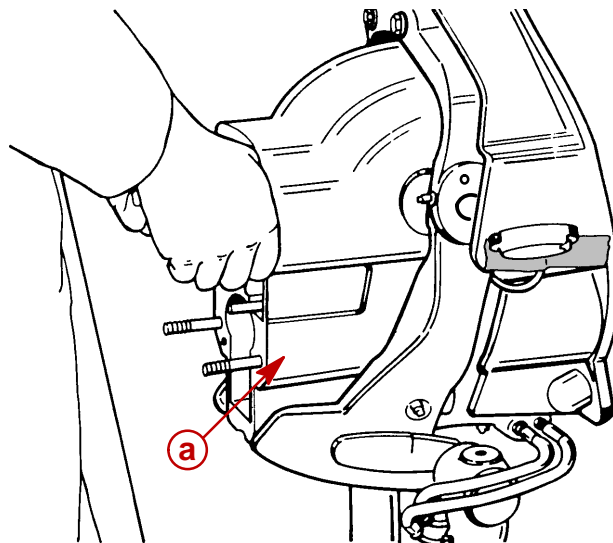

23363

- a - Bell Housing

5. Position U-joint bellows hose clamp as shown and tighten securely.

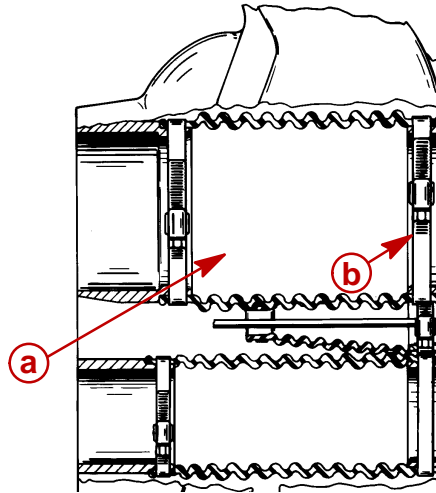

23158

- a** - U-Joint Bellows  
**b** - Clamp

6. Connect U-joint bellows to bell housing as follows:

- a. **Alpha Models** - Position U-joint bellows on bell housing. Ensure that the bell housing flange rests in the groove at the end of bellows.

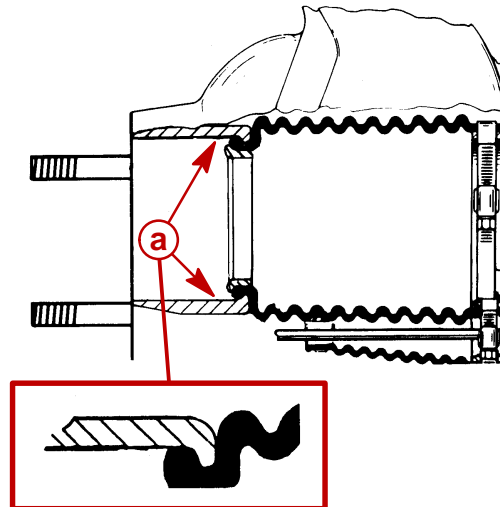

75268

- a** - Bell Housing Flange

- b. **Bravo/Blackhawk Models** - Position U-joint bellows on bell housing. Ensure that the bell housing flange rests in the second groove from the end of bellows.

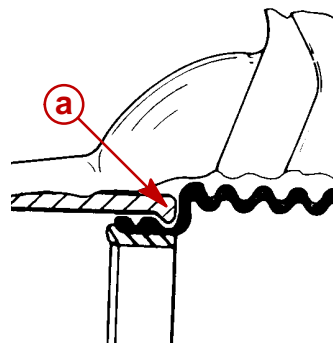

- a** - Bell Housing Flange

22116

- c. Lubricate sleeve O.D. with water or engine cleaner and install sleeve with tool and suitable driving rod.

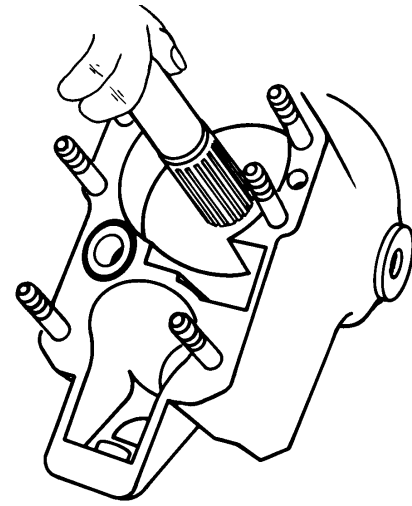
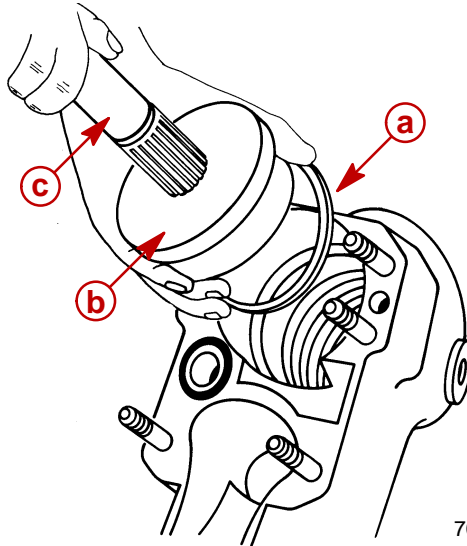

- a** - Sleeve
- b** - Installation Tool (91-818162)
- c** - Suitable Driving Rod

- 7. Apply Loctite 277 or 8831 to bell housing threads and install hinge pins. Torque Hinge Pins to:

**Alpha Models:** 95 lb. ft. (129 N·m)

**Bravo/Blackhawk Models:** 150 lb. ft. (203 N·m)

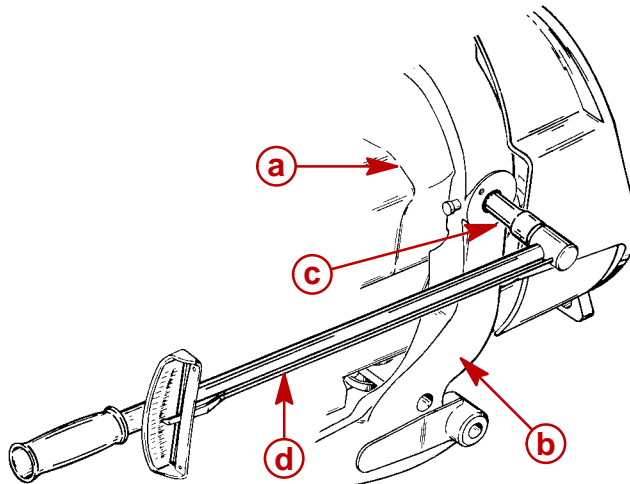

- a** - Bell Housing
- b** - Gimbal Ring
- c** - Hinge Pin Tool (91-78310)
- d** - Torque Wrench (lb. ft.)

- 8. Reinstall trim position sender as follows:

- a. Place stern drive unit in the full down/in position.

- b. Turn center rotor of trim position sender to align index mark with index mark on sender body.

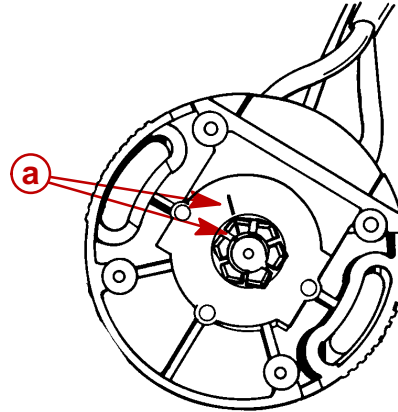

71218

**a** - Index Marks

- c. Install trim position sender and secure with attaching hardware.

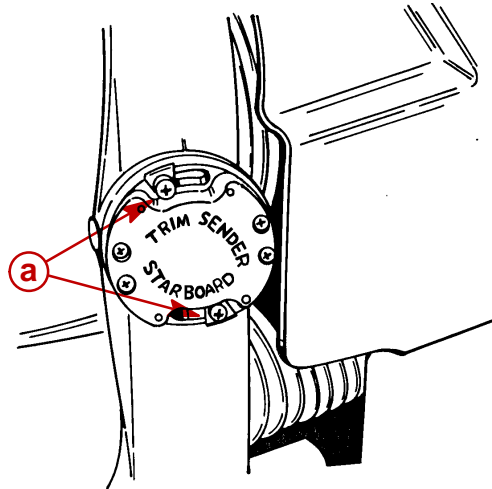

71220

**a** - Screws, Washers and Retainers

9. Reconnect trim position sender wires to engine harness.

**NOTE:** Trim position sender kit contains two jumper wires that can be used if your model requires ring terminals to connect to the engine harness.

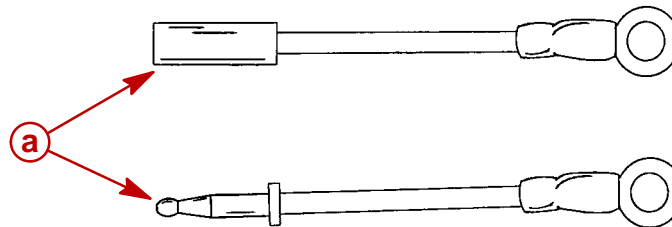

25269

**a** - Jumper Wires

10. Reinstall battery cables.

11. Turn ignition key to the "RUN" position. DO NOT START ENGINE. Rotate sender until needle is at bottom of arc on gauge.

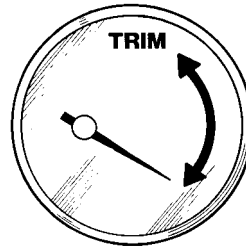

22175

12. Tighten trim position sender retaining screws and recheck gauge reading.
13. Reconnect trim limit switch wires to trim pump harness. Secure wires in retainer with sta-strap.

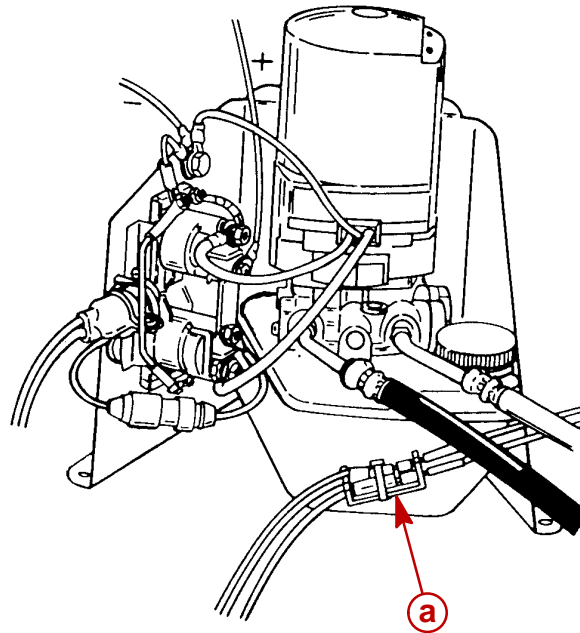

22031

**a** - Trim Limit Switch Wires

14. Reinstall trim limit switch as follows:
  - a. Place drive unit in full "DOWN/IN" position.
  - b. Align index marks on switch.

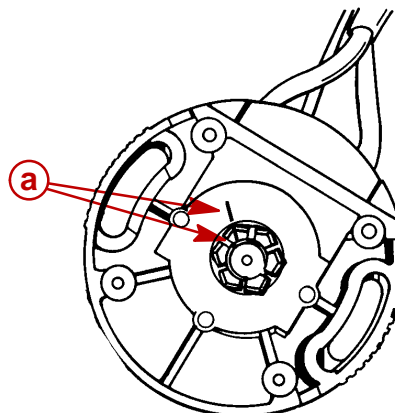

71218

**a** - Index Marks



- c. Install trim limit switch and secure with attaching hardware.

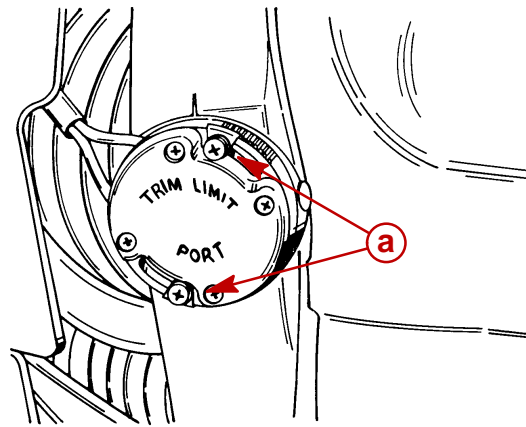

71221

- a** - Screws, Washers and Retainers

15. Secure the trim limit switch harness to the water hose with the plastic clip on later Alpha and Bravo/Blackhawk models.

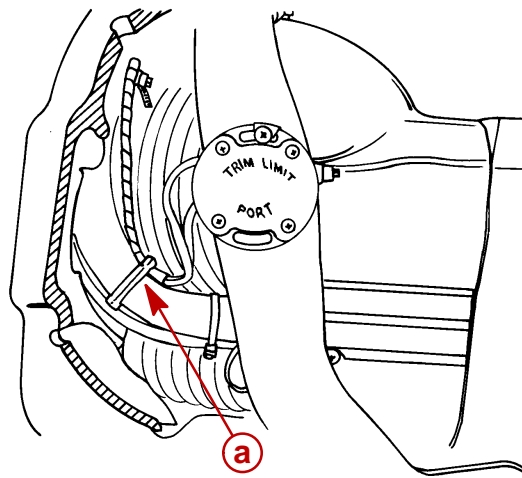

71184

- a** - Plastic Clip

16. Adjust trim limit switch as follows:

- a. Loosen screws and turn trim limit switch clockwise to end of slots.

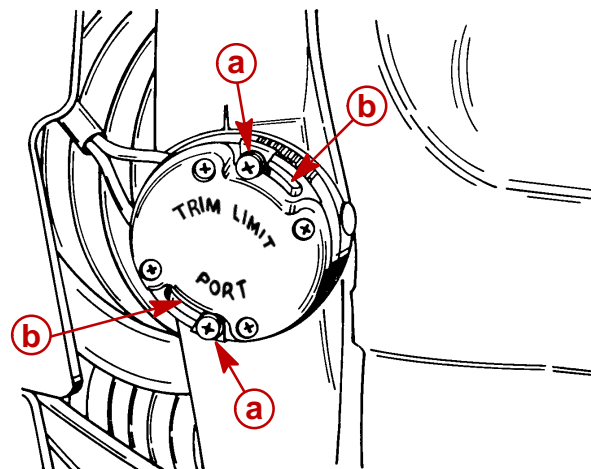

22091

- a** - Screws  
**b** - Slots

- b. Ensure drive unit is in the full “DOWN/IN” position.
- c. Trim drive unit “UP/OUT”. Do not use trailer switch.
- d. Slowly turn trim limit switch counterclockwise until trim cylinders extend to dimension shown (refer to appropriate illustration).

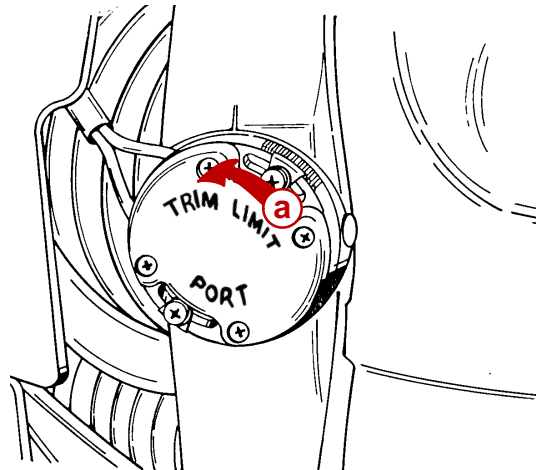

22091

**a** - Rotate Counterclockwise to Adjust

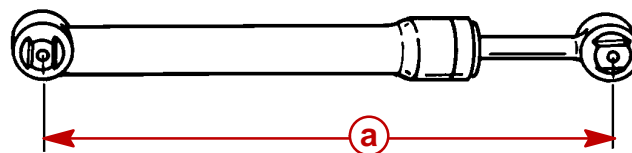

50464

**Earlier R/MR/Alpha One Models**

**a** - 21-3/4 in. (554 mm) Max.

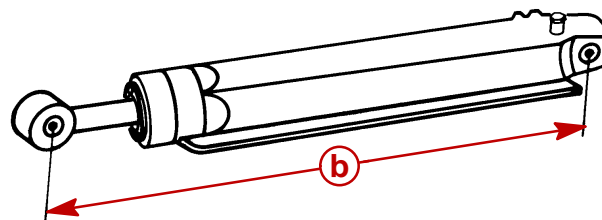

70136

**Alpha One Generation II Models**

**b** - 20-3/4 in. (520 mm) Max.

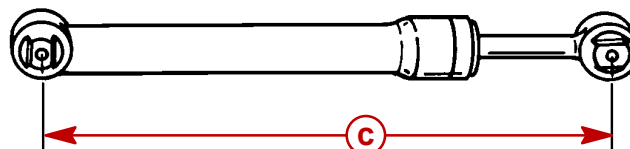

50464

**Bravo/Blackhawk Models**

**c** - 21-3/4 in. (554 mm) Max.

- e. Retighten screws when adjustment is correct.