

&l' Ø) '8l F7<; 5B; G@C7<
 A* 'l' * < '8l F7<; 5B; G@C7<
 Ø + L '% 'H-9; ž 5l ; ; 96C<FH
 ✓ Ø + ž 'L - \$šž CVYb
 ✓ Ø * ž 'L - \$šžl bHyb

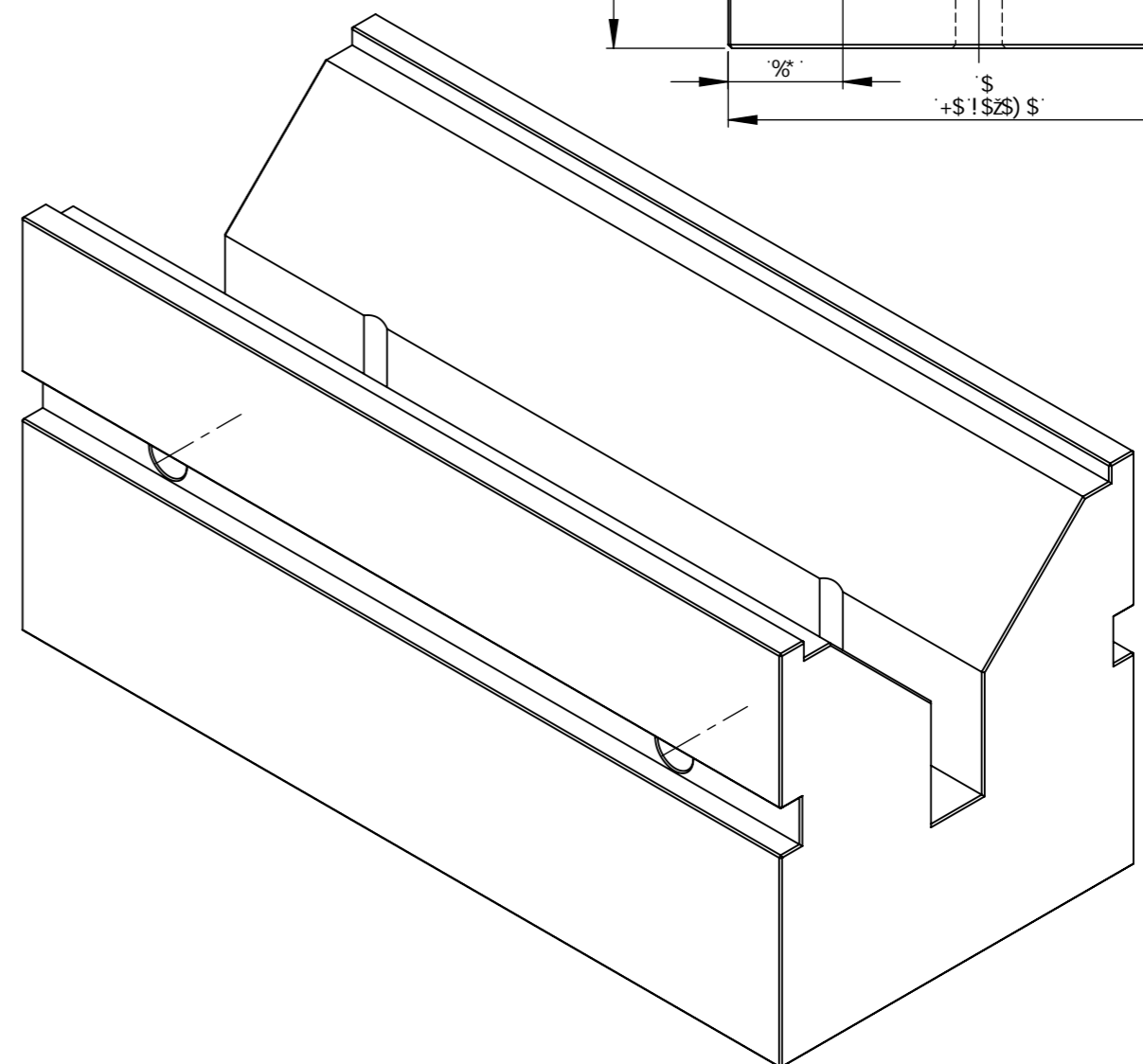
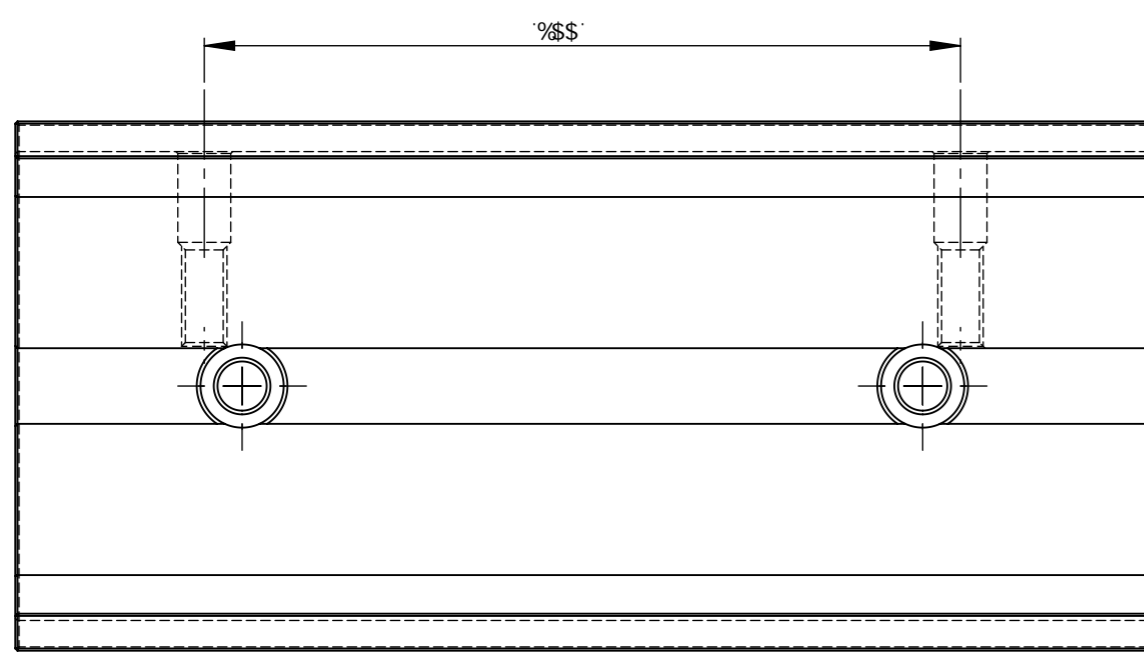
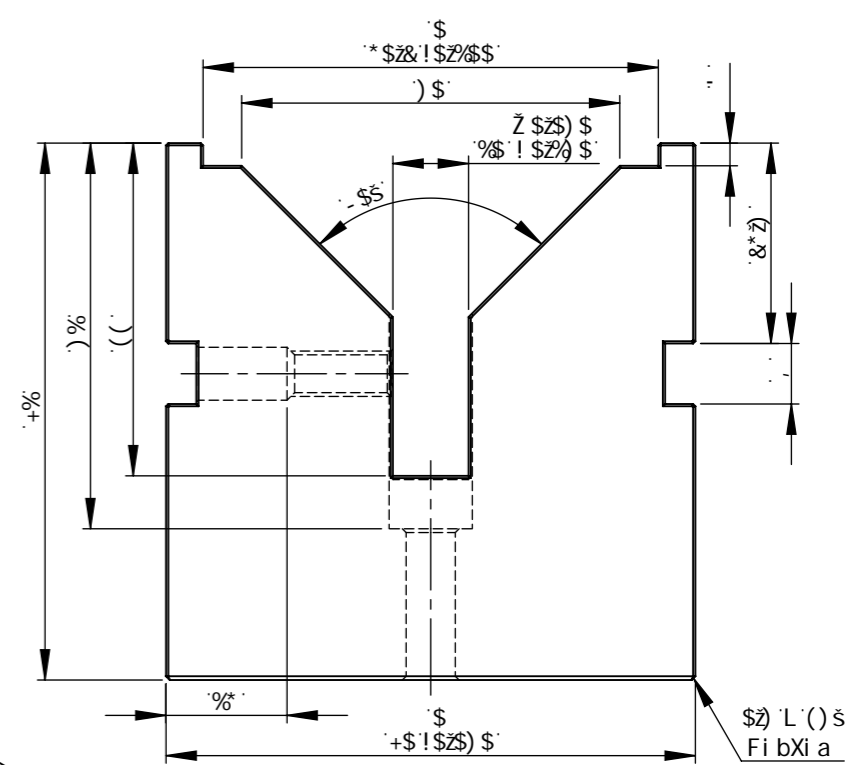

A UHYf]U!žK Yf_gfcZVYnY]Wbi b[9fgh' h		
DCA gWk Ufn	6YURVY]Hh	\$) "\$) "&\$%+	
CVYfZ} WYbUb[UY' bUW' 8-B' ' % (%	Gh W']ghY.		
CVYfZ} WYbgnā VcY.	6'UrtbUa Y.	6'Urt%] cb %	
AU' 'YFU Vh GāhY' Vg HU √ ⁿ	A UEgUV.	% %	5'

KITOTEC GMBH	YSA U]. ']bžc:4 kitotec.biz	Gc']XK cf_g
	-bHYfbYh 'k k k "kitotec.shop	
8.PGI S7UX7Ua PA SGYfj]WPS&S8K ; Pdf]ga US%ž \$SDCA!gWk Ufn		
6YbYbbi b[.	Df]ga US%ž \$SDCA!gWk Ufn	?i bXY.
	Dca 'Df]ga U%ž \$' Ub['gWk Ufn 7Hl *\$\$\$!B	9bgHUbXYb 'Ui g
		9fgY]rh' 5'' [Ya Y]b'
		Hc'YfUbn 8-B '=GC '&+*, . : Y]b