

DIMLUX

**EXPERT SERIES
& MKII**

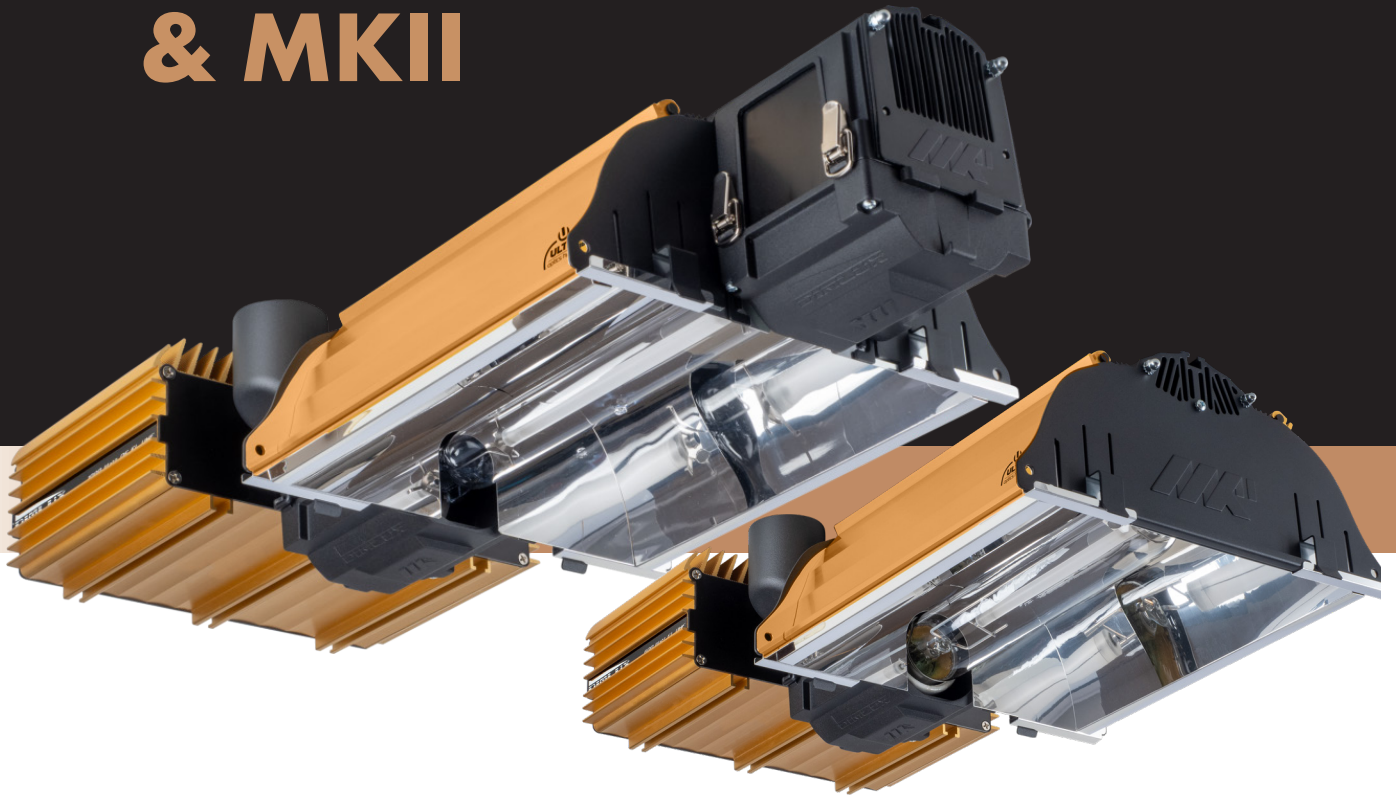

**DIMLUX
XTREME SERIES
LED**



**DIMLUX
PRO SERIES**

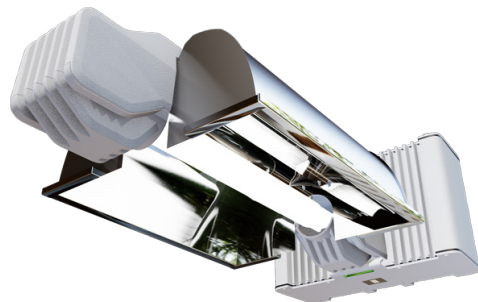

DIMLUX MAXICONTROLLER

THIS REVOLUTIONARY CONTROLLER CAN CONTROL
UP TO 160 DIMLUX FIXTURES AND IS EXPANDABLE
WITH VARIOUS SENSORS.



The Maxi Controller is a modular control system that allows you to manage the Dimlux lighting system. The Maxi Controller controls and monitors the CO₂, vapor pressure deficit (VPD) and the plant temperature depending on the sensors chosen and connected.

The Maxi Controller has the capacity to control up to 160 Dimlux fixtures. By means of a built-in timer, the Maxi Controller can switch the lighting system on or off automatically. Furthermore, the light intensity can be continuously adjusted to the desired value.

Using Dimlux the Dimlux Fixtures combined with the Dimlux Maxi Controller has several great advantages:

- Sunrise and sunset simulation
- Measurement of ambient temperature by sensor
- Measurement of relative air humidity by RH sensor
- Plant temperature measurement using a plant temperature
- Indication of evaporation pressure (VPD) when using above sensors
- CO₂ control by CO₂ sensor
- settings for minimum and maximum values of all sensors
- Control of extra fans, heaters, humidifiers or de-humidifiers (with the Smart Box)



OPTICLIMATE CO2 SENSOR

The OptiClimate CO2 sensor can be connected to the DimLux Controller and also controls the CO2 generator or CO2 pressure reducing valve. The sensors use NDIR Dual Beam technology that provides unprecedented calibration precision and stability. Other CO2 sensors are single beam and need to be calibrated regularly. Dual Beam sensors are two sensors in one where the measurement sensor is periodically adjusted by the second sensor. Because the second sensor is active for only 5 minutes per month, it does not age or drift.



TEMPERATURE SENSOR

The temperature sensor allows the Maxi Controller to dim the lights based on a grow environment's ambient temperature. If the set value is exceeded, the lights will dim to keep the temperature under control. If the temperature rises despite dimming, half of the dimmed lights will be switched off in a checkerboard pattern. If the temperature still continues to rise all lights will be switched off for at least 20 minutes.



HUMIDITY (RH) SENSOR

The RH sensor displays the ambient humidity on the Maxi Controller. If the RH sensor is connected, a humidifier can also be switched on with the Maxi Controller. If the VPD is to be displayed, the plant temperature camera and the ambient temperature sensor will also be required.



PLANT TEMPERATURE CAMERA

Plant temperature is more important than ambient temperature. When the camera is connected, climate can be controlled based on the plant temperature. If plant temperature gets too high, the Maxi Controller will dim the lights to keep the stomata open. In case of water shortage (e.g. due to a faulty pump) the lights are also dimmed or turned off to prevent crop damage.



SMART BOX

The Smartbox box has 3 outputs so that a heater, humidifier, dehumidifier and fan can be connected to the DimLux Maxi Controller. All outputs are 15A. The fan control is electronic and quiet in use (no hum). The fan controller has a temperature and RH control that are individually adjustable. The temperature controller works through SmartLogic, this is an algorithm that ensures that the current temperature is actually equal to the set temperature.

DIMLUX^{MKII}

EXPERT SERIES MKII



The MKII upgrade is a more efficient, functional and smarter light fixture. Because the electronics produce less heat, the ballast housing is more compact, the ballast is even more efficient, lighter, and smarter.

The MKII upgrade is a more efficient, functional and smarter light fixture. Because the electronics produce less heat, the ballast housing is 30% shorter.

For example, the Dimlux Expert 1000W MKII has the same length as the Dimlux Expert 600W.



8 DIM OPTIONS WITH 2 SPECIAL "BOOSTS"

Status and alarms will be displayed on this display. The DimLux Expert Series MKII ballast achieves the highest possible light output due to the overdrive technology (boost). This makes it possible to get a higher percentage light output.

Single push button for setting the power output:

Dimlux Expert 600/750W in steps of 300, 360, 420, 480, 540, 600, 680 and 750W.

Dimlux Expert 1000W in steps of 500, 600, 700, 800, 900, 1000, 1100, 1200W.

Dimlux Expert 1000/1250W CA in steps of 500, 600, 700, 800, 900, 1000, 1100, 1250W.

EASY CONNECTIVITY BY USING SMARTPORTS

The Dimlux Expert MKII is equipped with an extra interconnect port (Smartport) that can be used universally.

DIMLUX SENSORS

Another ballast can be connected to the Dimlux Expert MKII, but also, for example, a plant temperature camera or humidity sensor.

MORE EFFICIENT, MORE FUNCTIONAL, MORE COMPACT, LIGHTER & SMARTER!



The design of the reflector is optically perfect so that no hammered or textured pattern is needed to spread hotspots. Hammered or textured reflective reflectors are made to improve uniformity, but create undesirable multiple reflections inside the reflector and cause reflections from the reflector to the lamp causing a decrease in efficiency. The techniques used in our reflector combined with the use of Miro Silver mirror will provide unparalleled results.

EASY REMOVABLE ULTRA OPTICS REFLECTOR

Standard equipped with the Ultra Optics Hybrid 98 reflector. This reflector has the highest reflector efficiency in the market with 98% total efficiency, achieved through Miro 98 (99.99% silver) and the SBCS (Single Bounce Clear Sight) principle.

Easy to replace with the Ultra Optics Wide 98 reflector or Ultra Optics Deep 98 reflector. Both reflectors have a 98% efficiency just like the Ultra Optics Hybrid 98.

The main goal in designing the Ultra Optics Reflector was to achieve the highest efficiency (light output) possible. It's designed according to the SBCS (Single Bounce Clear Sight) principle which means that each light ray reflects only a single time in the reflector before exiting (Single Bounce). After reflection, the beam is not hindered by the lamp or other parts (Clear Sight).



DIMLUX^{MKII}

EXPERT SERIES 600/750W MKII

FITTED WITH OUR NEW

DXO
Dimlux Xtreme Output

ULTRA
optics hybrid 98



FEATURES

- Unparalleled and highly efficient ballast driver: 97% efficiency, 30% less losses, lighter, and 30% more compact than the old Dimlux Expert Series 1000W.
- Standard equipped with the Ultra Optics Hybrid 98 reflector. This reflector has the highest reflector efficiency in the market with 98% total efficiency.
- Single push button for setting the power output

Dimlux Expert 1000/1250W CA in steps of 500, 600, 700, 800, 900, 1000, 1100, 1250W.

Dimlux Expert 1000W in steps of 500, 600, 700, 800, 900, 1000, 1100, 1200W.

Dimlux Expert 600/750W in steps of 300, 360, 420, 480, 540, 600, 680 and 750W.

- 4-Character status display with scrolling text. Status and error codes are fully displayed on this display.
- Closed ballast design, for better protection of the electronics.
- Controllable with current Maxi Controller and the upcoming Smart Protocol platform.

SPECIFICATIONS

DIMLUX EXPERT SERIES 600/750W MKII EL UHF DXO

Dimlux Xtreme Output HPS 400V 600/750W EL Bulb

Light Output PAR (PPF 400-700nm)	1506 μ mol/s @750W
Light Output PAR Total (PPF 350-800nm)	1657μmol/s @750W
System Photon Efficacy PAR (PPE 400-700nm)	1,94 μ mol/J @700-750W
System Photon Efficacy PAR Total (PPE 350-800nm)	2,13μmol/J @700-750W
Voltage	230V \pm 10V
Power consumption @600W	616W 2.7A at 230V
Power consumption @750W	770W, 3.4A at 230V
Illumination surface @600W	min. 0.78m ² (8.39ft ²), max. 2m ² (21.52ft ²)
Illumination surface @750W	min. 0.95m ² (10.22ft ²), max 2.4m ² (25.83ft ²)
Dim levels	Soft-Off, 300, 360, 420, 480, 540, 600, 680, 750W
Input Frequency	50/60Hz
Power Factor	0.99
Ultra high frequency (UHF)	Yes
Controller	Maxi Controller
Dimensions	550x275x130mm (21.6x10.8x5.1")
Weight	5.1kg (11.24lbs)

EXPERT SERIES 1000W MKII



SPECIFICATIONS DIMLUX EXPERT SERIES 1000W MKII DE EL UHF DXO

Dimlux Xtreme Output HPS 400V 1000/1250W DE EL Bulb

Light Output PAR (PPF 400-700nm)	2558 μ mol/s @1200W
Light Output PAR Total (PPF 350-800nm)	2813μmol/s @1200W
System Photon Efficacy PAR (PPE 400-700nm)	2,07 μ mol/J @1150-1200W
System Photon Efficacy PAR Total (PPE 350-800nm)	2,27μmol/J @1150-1200W
Voltage	230V \pm 10V
Power consumption @1000W	1035W 4.5A at 230V
Power consumption @1200W	1242W, 5.4A at 230V
Illumination surface @1000W	min 1.4m ² (15.06ft ²), max 3.3m ² (35.52ft ²)
Illumination surface @1200W	min 1.65m ² (17.76ft ²), max. 4m ² (43.05ft ²)
Dim levels	Soft-Off, 500, 600, 700, 800, 900, 1000, 1100, 1200W
Input Frequency	50/60Hz
Power Factor	0.99
Ultra high frequency (UHF)	Yes
Controller	Maxi Controller
Dimensions	625x275x130mm (24.6x10.8x5.1")
Weight	6,3kg (13.88lbs)

EXPERT SERIES 1000/1250W MKII CALI SPEC



SPECIFICATIONS DIMLUX EXPERT SERIES 1000/1250W MKII EL UHF DXO CALIFORNIA SPEC

Dimlux Xtreme Output California Spec HPS 400V 1000/1250W DE EL

Light Output PAR (PPF 400-700nm)	2724 μ mol/s @1250W
Light Output PAR Total (PPF 350-800nm)	3008μmol/s @1250W
System Photon Efficacy PAR (PPE 400-700nm)	2,12 μ mol/J @1100-1250W
System Photon Efficacy PAR Total (PPE 350-800nm)	2,34μmol/J @1100-1250W
Voltage	230V \pm 10V
Power consumption @1000W	1035W 4.5A at 230V
Power consumption @1250W	1250W, 5.6A at 230V
Illumination surface @1000W	min 1,4m ² (15,06ft ²), max 3,3m ² (35,52ft ²)
Illumination surface @1250W	min 1,65m ² (17,76ft ²), max. 4m ² (43,05ft ²)
Dim levels	Soft-Off, 600, 700, 800, 900, 1000, 1100, 1250W
Input Frequency	50/60Hz
Power Factor	0.99
Ultra high frequency (UHF)	Yes
Controller	Maxi Controller
Dimensions	625x275x130mm (24.6x10.8x5.1")
Weight	6,3kg (13.88lbs)

GOING WHERE NO BULB HAS EVER GONE BEFORE!

MADE TO BOOST

DXO

Dimlux Xtreme Output

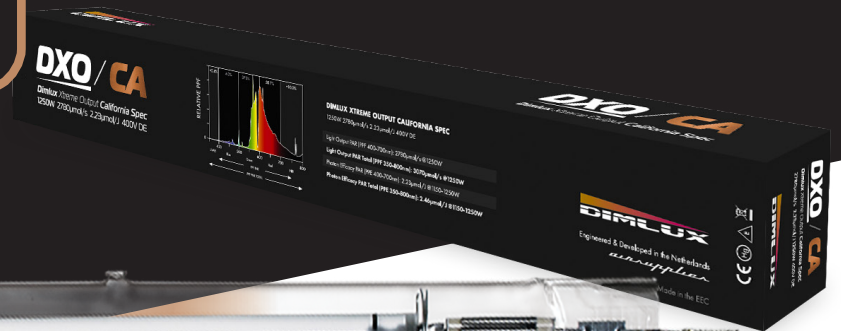

>95% PAR MAINTENANCE AFTER

10.000

Burning hours



THE ONLY BULB IN THE WORLD TO MEET THE HORTICULTURAL LIGHTING MINIMUM EFFICACY 2022 (2023) CALIFORNIA ENERGY CODE*

*To meet the new requirement the new DXO [Dimlux Xtreme Output] CaliSpec bulb needs to be used in combination with the Dimlux Expert 1000/1250W MKII

DIMLUX

© The Climate Factory 2023



DIMLUX EXPERT SERIES

FULL SPECTRUM

ALPHA OPTICS 98 REFLECTOR

This Alpha Optics 98 reflector was designed according to the Single Bounce Clear Sight (SBCS) principle and is equipped with Miro Silver mirrors.

This achieves the highest possible level of efficiency (98%) of any commercially available horticultural reflector. The reflector is fitted with adjustable side reflectors for better overlapping and minimizing wall losses.

DIMLUX EXPERT SERIES FIXTURES AND XTREME BALLASTS

- The highest output (light due to the overdrive boost) and 400V technology
- The broadest dimming range of all digital ballasts
- Soft-Start, Soft-Dim, Soft-Off function
- Can be dimmed manually in 8 levels including the "off" position.
- Can be variably dimmed via the Maxi Controller
- Extensive diagnostic LEDs
- EOL function (indication to replace lamps)

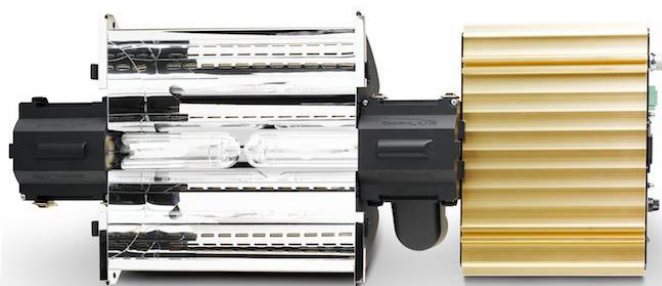
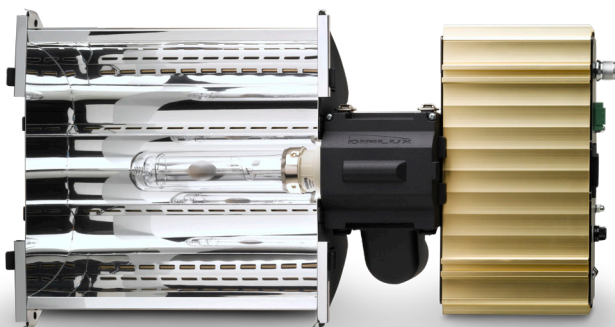

EXPERT SERIES 315W FULL SPECTRUM

Complete fixture with 315W Xtreme ballast, 315W Full Spectrum Dimlux bulb and Alpha Optics 98 Reflector

EXPERT SERIES 630W DUAL FULL SPECTRUM

Complete fixture with 630W Xtreme ballast, 2x315W Full Spectrum Dimlux bulb and Alpha Optics 98 Reflector

315W FULL SPECTRUM

Dim levels:	Soft-Off, 165W, 205W, 245W, 280W, 315W, 345W, 380W
Power consumption at 315W	331W 1,4A at 230V
Power consumption at boost 380W =	399W 1,7A at 230V
System PPF at 380W =	706umol
Illumination surface:	at 315W = mín. 0,42m ² / máx. 1m ² at 380W = mín. 0,5m ² / máx. 1,2 m ²
Connection	ø50mm (2") connection for active extraction
Dimensions:	530x275x130mm
Weight:	4,9kg

630W FULL SPECTRUM

Dim levels:	Soft-Off, 330W, 410W, 490W, 560W, 630W, 690W, 760W
Power consumption at 630W	662W, 2,7A at 230V
Power consumption at boost 760W =	799W, 3,5A at 230V
System PPF at 760W =	1411 umol
Illumination surface:	at 630W= min 0.84m ² (9.04ft ²), max 2m ² at 760W= min 1m ² (10.76ft ²), max. 2.4m ²
Connection	ø50mm (2") connection for active extraction
Dimensions:	675x275x130mm
Weight:	6,3 kg

DIMLUX PRO SERIES



The reflector with
maximum horticultural
efficiency

+96%

System
PPF @ 1150W
2339 μ mol/s

The Dimlux Pro has a passively cooled Ultra Optics reflector in order to get the optimum lamp temperature and highest light output. By using Miro 95 (99,99 aluminium) instead of Miro Silver for the reflector, we prevent deterioration in high humidity when scratched. The Ultra Optics reflector is available in 3 different styles of reflectors, Hybrid (default), Deep and Wide and can be changed quickly and easily, even at high heights.

The ballast is ready for the new digital controller platform, and is upgradable. The Pro series has a closed ballast instead of an open ballast. This protects the ballast from moisture. The Geo Membrane equalizes the pressure inside and outside the ballast, while still preventing condensation on the electronics.

The vertically mounted ballast will decrease the amount of daylight which is blocked by the fixture. We have done daylight simulations in CAD and this design had the least light interception during a full daylight cycle.

The output of the Dimlux Pro Series can be controlled up to 115%, both by using the dim button and by remote control. With the manual power settings 500, 600, 700, 800, 900, 1000, 1075 and 1150W you have a wide range of settings available.

Status and alarms are displayed on a four-character display making your Dimlux Pro even more easy to use (except for the analogue version).

CLOSED & VERTICAL BALLAST

The Pro series has a closed ballast instead of an open ballast. This protects the ballast from moisture. The ballast is mounted vertically to decrease the amount of daylight which is blocked by the fixture. We have done daylight simulations in CAD and this design had the least light interception during a full daylight cycle.

EASY REMOVABLE & PASSIVELY COOLED ULTRA OPTICS REFLECTOR

Because the easier it gets the better and quicker it is especially when the reflector will be changed at high heights for replacement or cleaning. Available with 3 different styles of reflectors, Hybrid (default), Deep and Wide. The reflector is passively cooled In order to get the optimum lamp temperature and highest light output.

DIMLUX PRO

SPECIFICATIONS



Dimlux Pro Series 1000W	230V	400V
AC	2-734	2-733
Ultra High Frequency (UHF)	Yes	Yes
Controller	Maxi Controller / By WIFI	Maxi Controller / By WIFI
Measurements (L *W*H)	538 x 248 x 115 mm	538 x 248 x 115 mm
Weight	4,1 kg	4,1 kg
Boost	15%	15%
Power Inlet	230V Power plug 2m	Ep 3 PINS 400V F
Reflector	Single Bounce Clear Sight	Single Bounce Clear Sight
Light Source	HPS 1000W HPS 2K 2100µmol/s	HPS 1000W HPS 2K 2100µmol/s
Certifications	CE	CE
System PPF@ 1000W	2016µmol/s	2016µmol/s
System PPE@ 1000W	1,955µmol/J	1,955µmol/J
System PPF@ 1150W	2339µmol/s	2339µmol/s
System PPE@ 1150W	1,97µmol/J	1,97µmol/J
Power Factor	<0,95	<0,95
Voltage	230V	400V
Input power @ 100%	1035W	1032W
Input current @ 100%	4,55A	2,6A
Input power @ boost	5,2A	3,0A
Input frequency	50/60 Hz	50/60 Hz



DIMLUX XTREME SERIES LED

INTRODUCING THE MOST POWERFUL AND SMART LED GROWLIGHT ON THE MARKET! THE DIMLUX XTREME SERIES LED.

12 Years ago, Dimlux introduced the first ever ground breaking remote controlled HPS ballast in combination with the Maxi Controller; The Dimlux Xtreme Series. Today, Dimlux introduces the smartest, most efficient and most powerful grow light on the market, the **Dimlux Xtreme Series LED!**

With this innovative LED fixture, Dimlux sets a benchmark for horticultural lighting.

With patented technology, advances in LED technology, and optimal thermal design, the **Dimlux Xtreme Series LED** will be the preferred option offering significant return on investment to cultivators. Our adjustable PhytoVegSpec® grow spectrum combines full control over light quality (spectral flexibility) and quantity (intensity and DLI) ensuring a uniform spread and even light distribution with extreme penetration into the canopy.

The **Dimlux Xtreme Series LED** produces ultra-high levels of PPFD, evenly spread over a 1.2x1.2m grow area (500W) or a 1.5x1.5 m grow area (750W and 1000W), with a full grow spectrum, producing consistently high quality & high yield indoor crops.

The **Dimlux Xtreme Series LED** can be dimmed without losing efficiency. The spectrum and output power can be programmed depending on the time of day and the growing stage of the crop.

Auxiliary RGB LEDs with over 65k colors can be used as supplemental light and can be used as green work light in the dark phase. The work light can automatically be switched on by the internal radar proximity sensor.

Dimlux Xtreme Series LED – NIR

NIR means Near InfraRed. NIR is red light that becomes visible with a thermo graphic camera. It is therefore not directly visible to the naked eye, but is usefull for the crop.

The theory that this part of the color-spectrum would not contribute to photosynthesis is outdated. New studies have shown that when the red spectrum and NIR are combined, the sum is equal to or even greater than the individual parts. So the colours Red and Near-InfraRed must be combined to work properly.

In this combination, NIR also provides extra stretching and gives a fuller crop. DIMLUX LED with morphological properties ensures that the crop grows better in a broader spectrum.



DIMLUX

XTREME SERIES 500W LED



Light Source	LED
Spectrum	Adjustable PhytoVegSpec® Indoor
Light Output (PPF)	1571 $\mu\text{mol/s}$
System Efficacy	2.91 $\mu\text{mol/J}$ @ 230V AC
AC Input Power	540W @ 230V AC
AC Input Voltage	120-277V AC, 50/60Hz
Beam Angle	90° × 120°
Optics	Patented Deep Penetration Ultra High Transmittance Lens
Auxiliary Light	Patented Light Pipe Multi Color 65k
Proximity sensor	Doppler Radar
Thermal Management	Passive
Max. Ambient Temperature	40°C / 105°F
Control	By Maxi Controller or Internal Controller
Smartports (3x)	Interlink, Plant Temperature Sensor, Light Sensor
Display For Spectrum and GUI	1.54" 65k Color IPS
Total Harmonic Distortion (THD)	< 10%
Lifetime L90	> 50,000h
Certifications	CE, UL 8800, UL 1598 Wet Location, DLC
Warranty	5 Year Standard

TOP VIEW

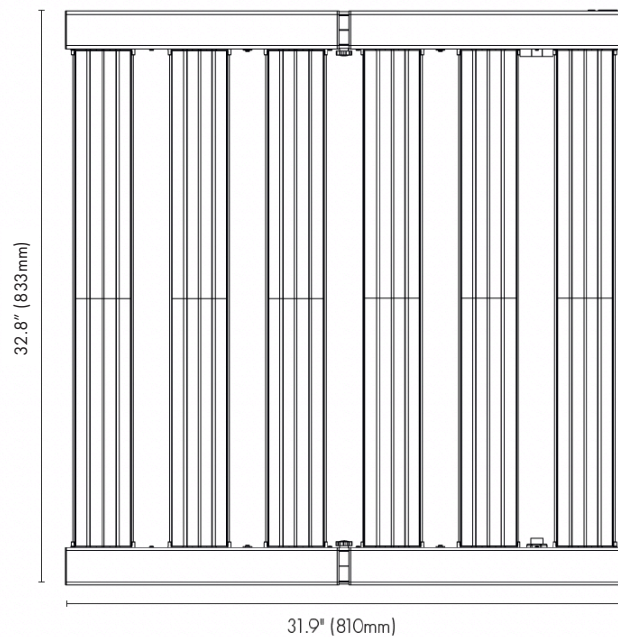

SIDE VIEW

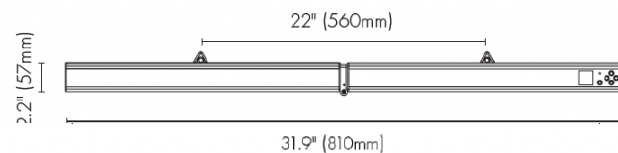

SPECTRA Adjustable PhytoVegSpec® Indoor

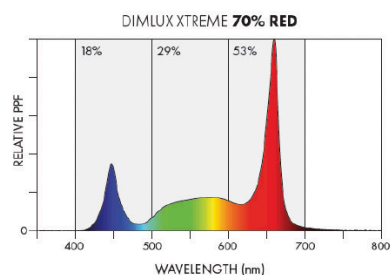
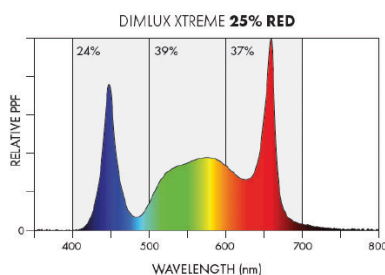
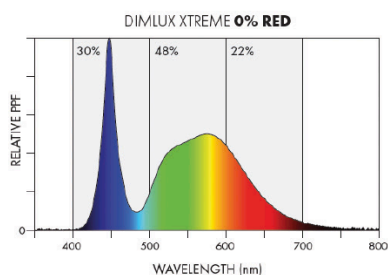

DIMLUX

XTREME SERIES 750W LED



Light Source	LED
Spectrum	Adjustable PhytoVegSpec® Indoor
Light Output (PPF)	2357 $\mu\text{mol/s}$
System Efficacy	2.95 $\mu\text{mol/J}$ @ 230V AC
AC Input Power	799W @ 230V AC
AC Input Voltage	120-277V AC, 50/60Hz
Beam Angle	90° × 120°
Optics	Patented Deep Penetration Ultra High Transmittance Lens
Auxiliary Light	Patented Light Pipe Multi Color 65k
Proximity sensor	Doppler Radar
Thermal Management	Passive
Max. Ambient Temperature	40°C / 105°F
Control	By Maxi Controller or Internal Controller
Smartports (3x)	Interlink, Plant Temperature Sensor, Light Sensor
Display For Spectrum and GUI	1.54" 65k Color IPS
Total Harmonic Distortion (THD)	< 10%
Lifetime L90	> 50,000h
Certifications	CE, UL 8800, UL 1598 Wet Location, DLC
Warranty	5 Year Standard

TOP VIEW

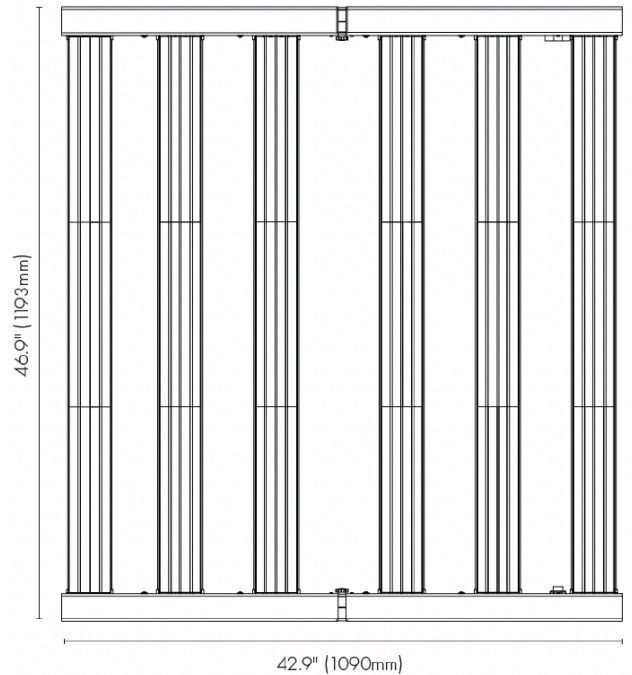

SIDE VIEW

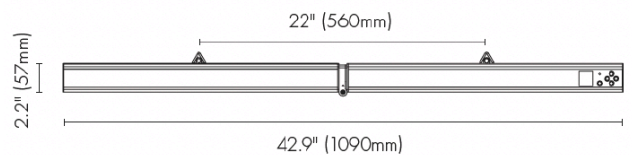

SPECTRA Adjustable PhytoVegSpec® Indoor

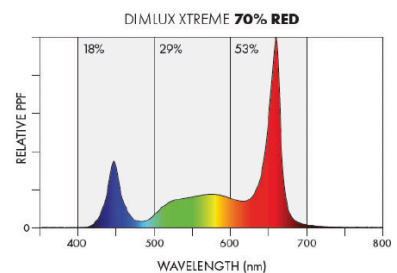
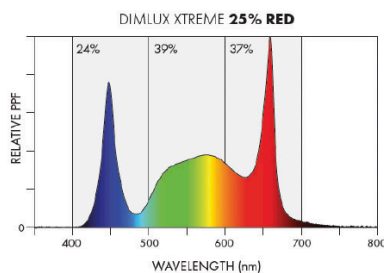
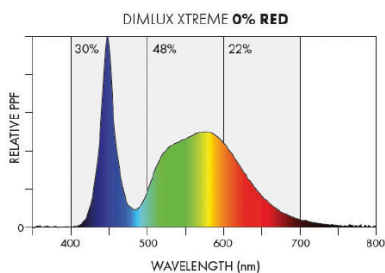

DIMLUX

XTREME SERIES 1000W LED



Light Source	LED
Spectrum	Adjustable PhytoVegSpec® Indoor
Light Output (PPF)	3142 $\mu\text{mol/s}$
System Efficacy	2.95 $\mu\text{mol/J}$ @ 230V AC
AC Input Power	1065W @ 230V AC
AC Input Voltage	120-277V AC, 50/60Hz
Beam Angle	90° × 120°
Optics	Patented Deep Penetration Ultra High Transmittance Lens
Auxiliary Light	Patented Light Pipe Multi Color 65k
Proximity sensor	Doppler Radar
Thermal Management	Passive
Max. Ambient Temperature	40°C / 105°F
Control	By Maxi Controller or Internal Controller
Smartports (3x)	Interlink, Plant Temperature Sensor, Light Sensor
Display For Spectrum and GUI	1.54" 65k color IPS
Total Harmonic Distortion (THD)	< 10%
Lifetime L90:	> 50,000hrs
Certifications	CE, UL 8800, UL 1598 Wet Location, DLC
Warranty	5 Year Standard

TOP VIEW

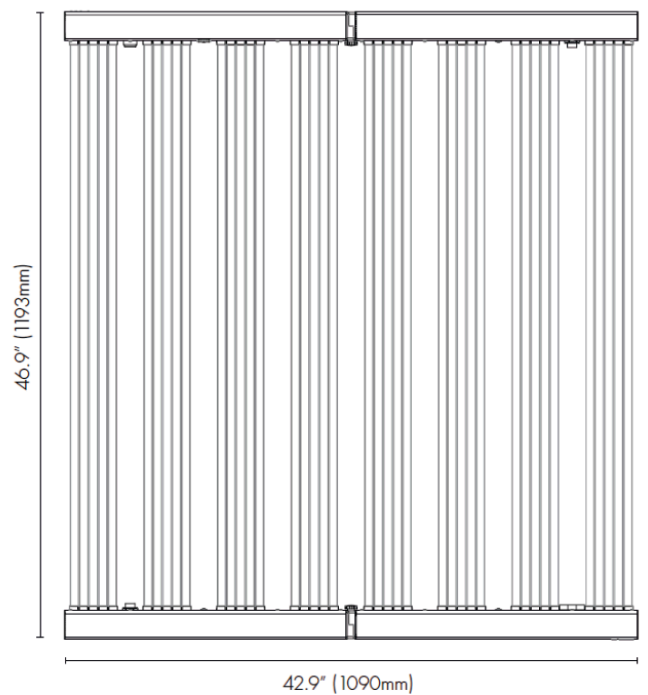

SIDE VIEW

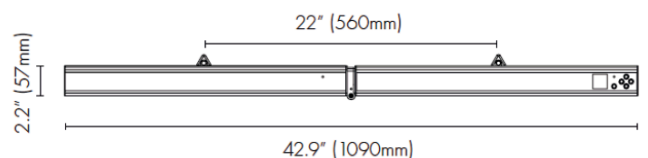

SPECTRA Adjustable PhytoVegSpec® Indoor

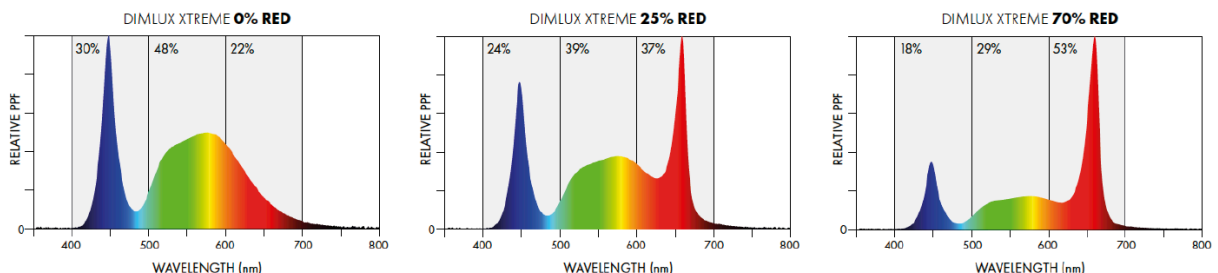



The official distributor of **Dimlux** and **Opticlimat** products for **Europe**

for details and branches visit our website

www.theclimatefactory.com

