



# REVOMAX II

BY OPTICLIMATE



## INSTALLATION & USER GUIDE

www.theclimatefactory.com



**PLEASE READ THE FOLLOWING INFORMATION CAREFULLY BEFORE USING THE UNIT:**

- High Temperature Safeguard on **page 7**
- Delete alarm history on **page 12**
- Dehumidify without cooling pro4 on **page 12**

# INSTALLATION

## Installation

### Installation spacing

To guarantee proper air suction, leave at least 15cm of space between the wall and the backside of the unit, where the carbon & dust filters and air inlet are located. At least 15cm of space should also be left between the topside of the unit and the ceiling. Larger spaces are preferred. The unit must stand free from the wall to avoid contact noises.

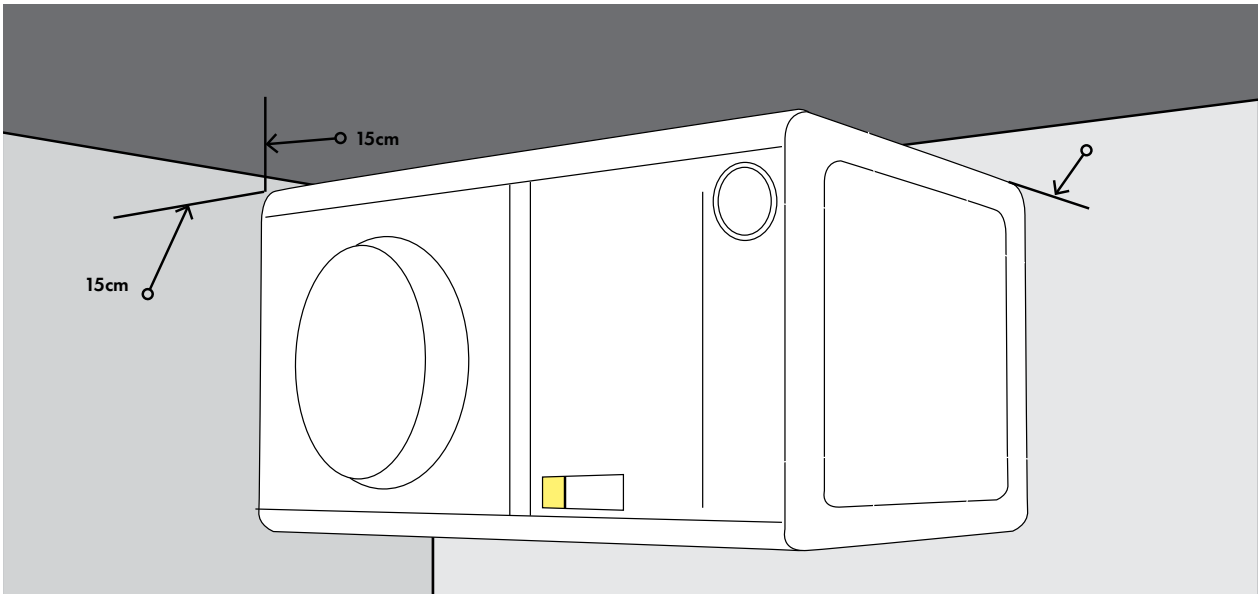

### Installation

The unit can be hung from a ceiling or placed on a stand or frame.

#### Ceiling

To hang the unit from a ceiling, remove both side panels and pinch a hole through the insulation at the position of the 4 holes in the bottom of the unit. Use an M8 or M10 metal threaded rod with a nut, washer and rubber damper to prevent unwanted noise or vibration.

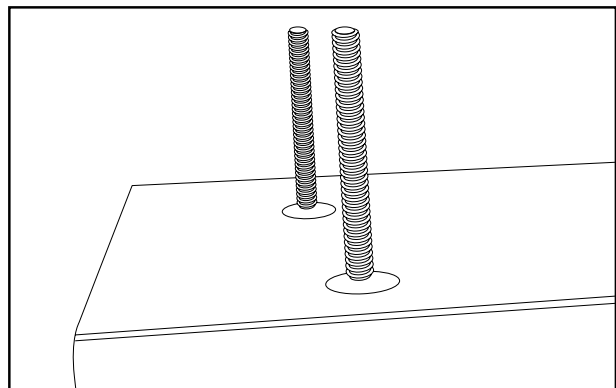
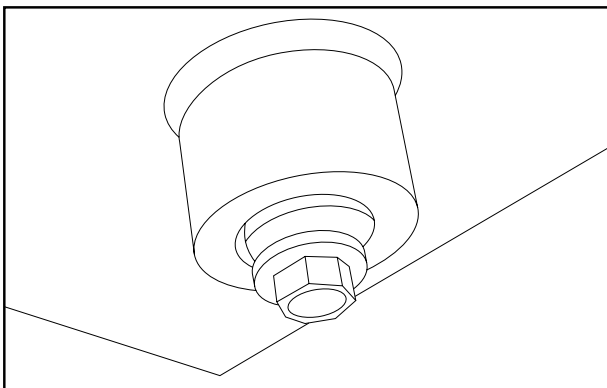

## INSTALLATION

### Stand or frame

Make or buy a stand or frame to hold the weight of the Opticlimate. (see nameplate )

You can use the rubber damper or a vibration damper (not included)

Pinch a hole through the insulation at the position of the 4 holes in the bottom of the unit. Use an M8 bolt and washer to mount the rubber or damper.

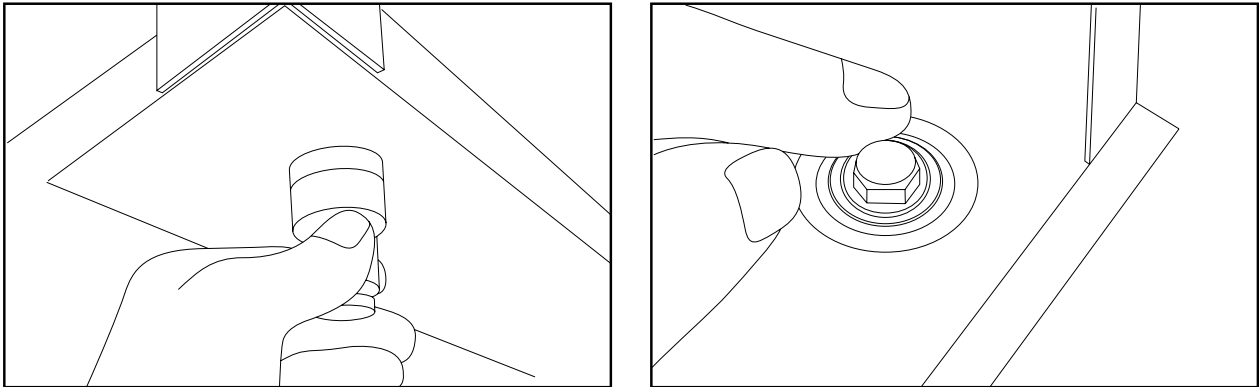

Make sure the side of the condensation outlet is 1 cm lower than the opposite side.

### Routing the Cables

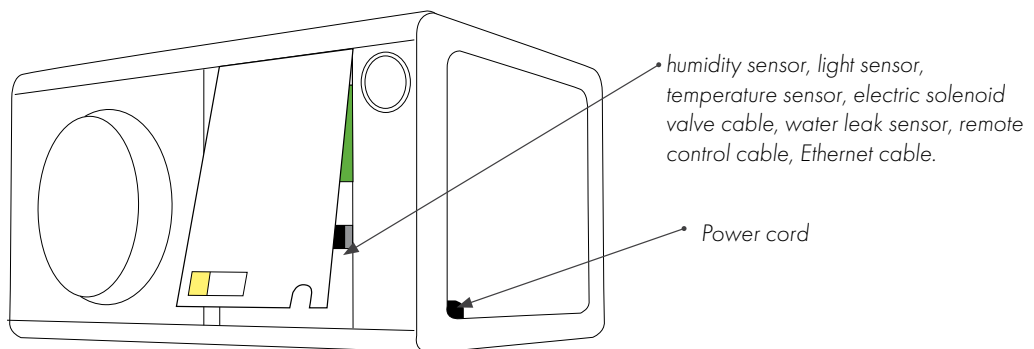

First, the panel at the left side near the manometer should be removed to make the various electrical connections.  
A magnetic valve, water leakage sensor, automatic moisture meter, remote control and room

temperature sensor are supplied with the unit. Their cables can be led to the outside through the opening at the bottom of the panel.  
The power cable for the power supply can be led through the black feed-through rubber at the side of the unit.

## ELECTRICAL CONNECTION

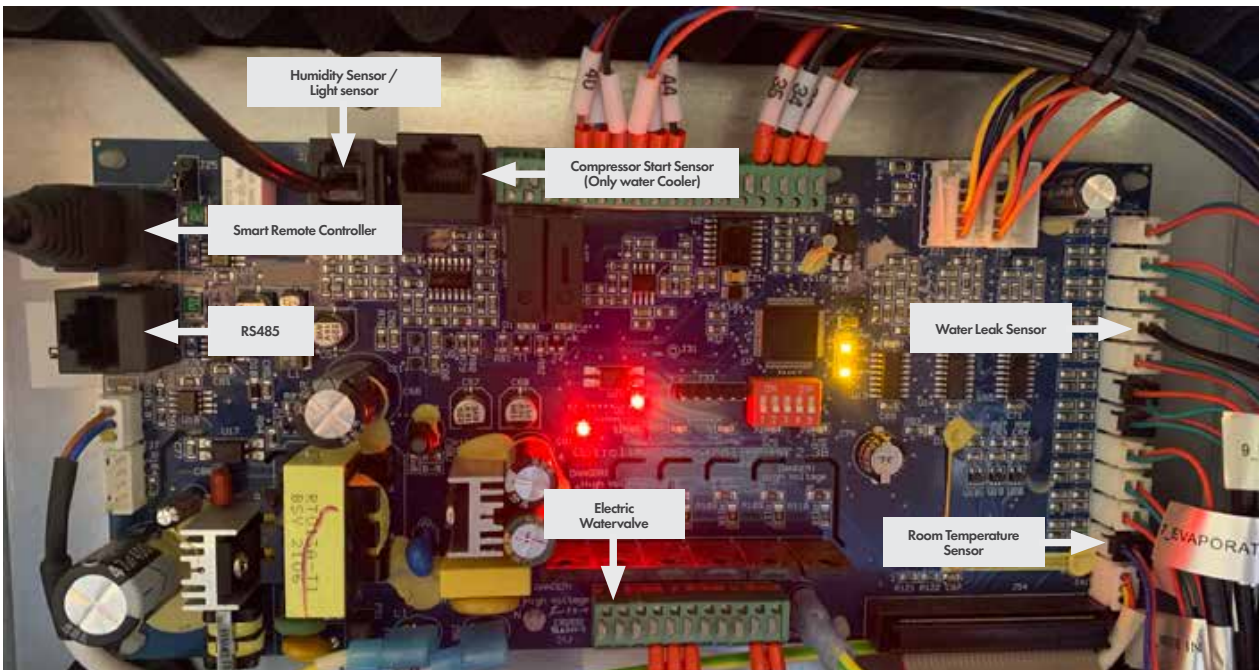

### Automatic Humidity Sensor with light cell

The Automatic Humidity Sensor with light cell supplied with the unit can be found in the connection set supplied with Revomax. The cable should be led through the opening in the front panel and connected to the circuit board (see picture) The sensor should be hung in the room and may not be covered. The light cell determines if it's night or day.

### Room temperature sensor

The connection set also contains a room temperature sensor, which needs to be connected to the printed circuit-board. This sensor should be led to the outside through the opening in the panel and should be hung at the level of the upper side of the vegetation. The sensor should be protected against heat radiation and must be put in the shade. A protective cover over the sensor is sufficient.

### The Smart Remote Controller

The smart remote controller can be found in a separate black box, the cable to connect the smart remote controller can be found in the connection set. The cable must be led through the opening in the panel and the UTP connector must be connected to the circuit board (see picture) The USB side of the cable can be plugged in one of the USB ports on the smart remote controller.

### Power supply specifications

4 different OptiClimate models are available. For your safety and the safety of the OptiClimate, the following specifications should be observed when connecting the power supply: use the circuit breakers (MCB) and cable thickness specified.

The cables for the supply voltage should be led through the grommet at the side of the unit and connected to the green screw terminal on the circuitboard as described in the illustration. The grounding can be connected to the PE at the bottom right of the metal back plate.

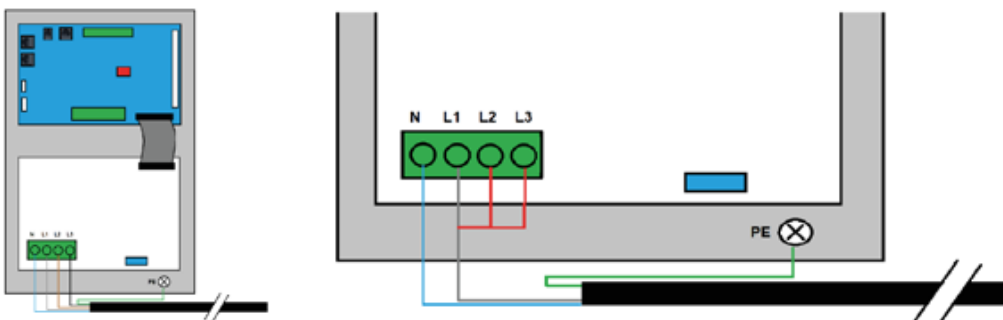

## WATER CONNECTIONS

### Water-in and water-out connections of the cooling water.

The unit can be used by connecting the water in and out connections to a cold water supply and a drain or can be used using the Opticlimat water cooler to cool the water in a closed loop. (connections and discription of a water cooler setup need to be obtained in the water cooler manual. Only the setup using a cold water supply and a drain are discribed in this manual.

Using a water cooler or other closed loop systems skip to page \*

The unit has a water inlet and outlet. The inlet needs to be connected to a cold water supply (max 25°C) with a solenoid valve installed at the beginning of the piping going to the Opticlimat water-in connection. In case of a waterleak the valve will close. Mounting the valve at the end of the piping (near the Opticlimat) is pointless. (always check the flow direction arrow on the valve!). Make sure that the black magnetic coil of the solenoid valve is positioned upwards (preferred) or to the side. If it is positioned downwards, condensate from the cold valve might enter the coil. Make sure that the solenoid valve is installed at a fixed point that is always easily accessible to the user.

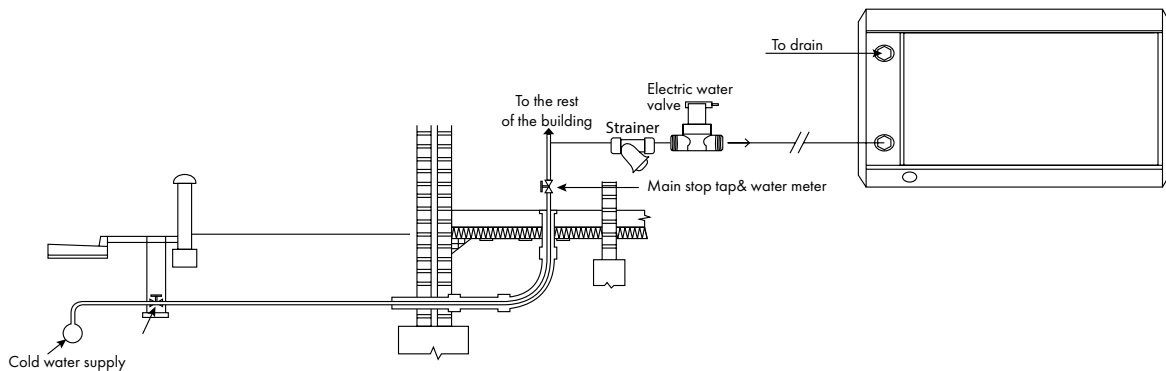

A strainer should be placed in the water inlet. This strainer prevents blockage in the heat exchanger inside the unit. It is recommended to insulate the cold water supply line in order to prevent condensation build-up. The upper water connection is the water-outlet. The water-outlet can be connected directly to the drain (sewer). Alternatively, the warm water can be used for heating purposes. The water is aprox 35°C- 40°C.

The water flow (water usage) is automatic regulated by an electronic flow regulator inside the unit.

When you use an alternative cold water supply such as a well or water from a river, lake or pond, make sure the water is filtered and clean the heat exchanger on a regular basis. Contact tech support for more information regarding cleaning the heat exchanger.

## CONDENSATION WATER

### Discharge of the condensation water

The unit will dehumidify the air during cooling and in dehumidify mode. The moisture extracted from the air is collected in the condensation pan. The condensation pan has an  $\frac{3}{4}$  drain pipe where the condensate will run off. The condensate can be used as irrigation water. The cooling block has been modified to prevent metals or oxides from entering the condensate water.

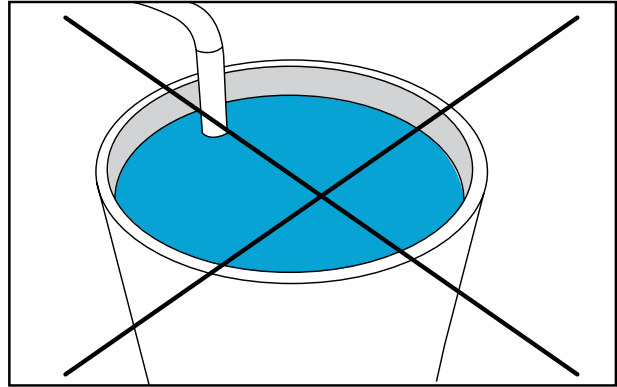
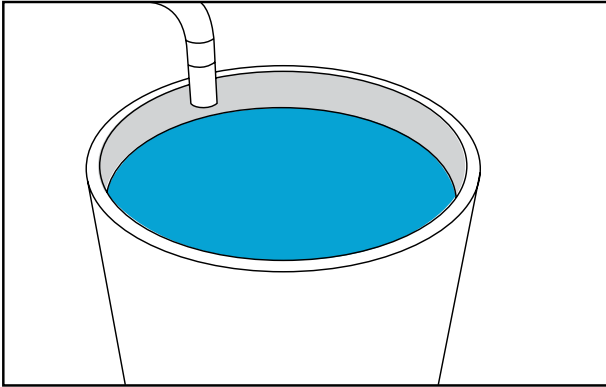

The location of the drain pan is on the negative pressure side of the unit, meaning that air can enter into the unit through the condensation drain. It's highly recommended to use a "P-trap" on the condensation outlet to prevent air entering the unit and to prevent condensate run-off problems. Not using a p trap also results in loss of capacity and bypassing non processed air.

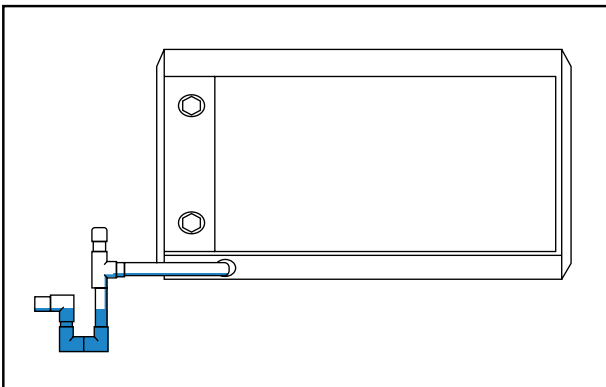

Condensation drain connection

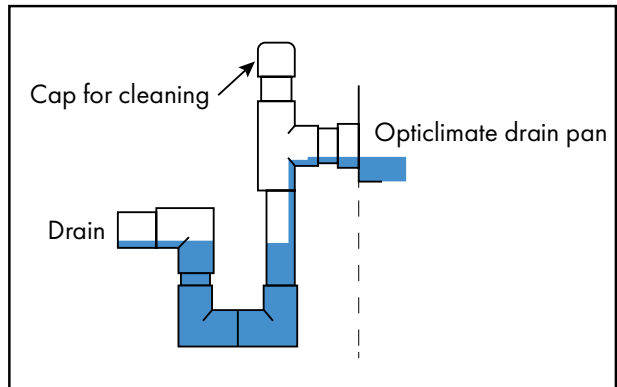

Correct drain installation

If the unit is installed at the same level or lower than the drain or sewer, a condensation lift pump can collect the water. This small lift pump pumps the water through a hose of 9mm to a height of 4 metres into the drain or collecting tank. Stronger pumps are also available.

## SMART REMOTE CONTROLLER

### Connecting the Smart Remote Controller



#### Power

Connect the power supply and USB connector from the remote cable to the Smart Remote controller.



↑  
USB to connect remote

↑  
HDMI to connect monitor (view only)

↑  
Ethernet

↑  
Power supply from adapter

#### Connections

At the back of the Smart Remote Controller you find the USB, HDMI, Ethernet and power supply connections.

## CONNECTING THE SMART REMOTE CONTROLLER

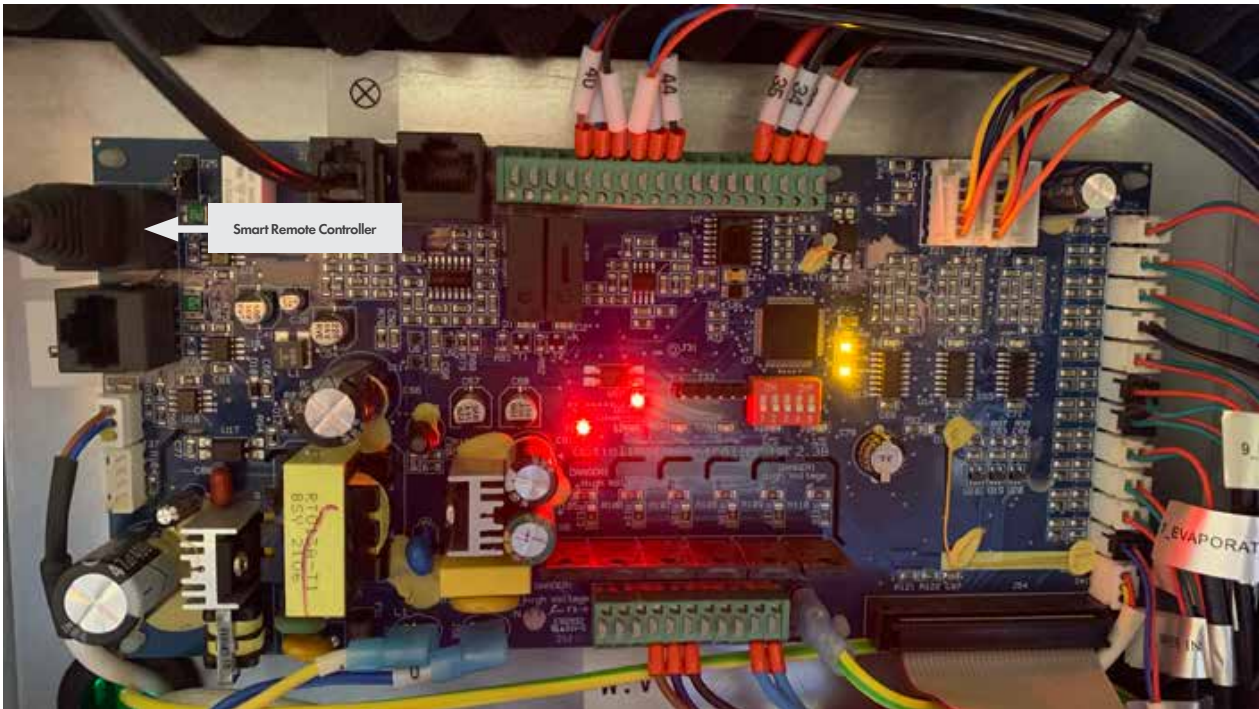

Connect the RJ45 side of the remote control cable to the RJ45 plug at the left upper corner of the circuit board (see image)

### Powering up the unit

- Power on the Smart Remote Controller
- Power on the Opticlimate by switching on the power supply.
- Open the water supply.

After powering up the Opticlimate, the unit will first initialize, this can take a few minutes.

All valves and sensor are tested prior to startup. The remote controller cannot be operated during initializing of the Opticlimate.

After powering up the Smart remote controller, the remote will first initialize, this can take a few minutes. You will see several screens pop-up and close again, this is normal.

 The unit is now installed and ready to use



## OPERATING BY USING THE SMART REMOTE CONTROLLER

After both Smart controller and Opticlima are initialised, the Smart Remote controller will display the Home screen \* 1

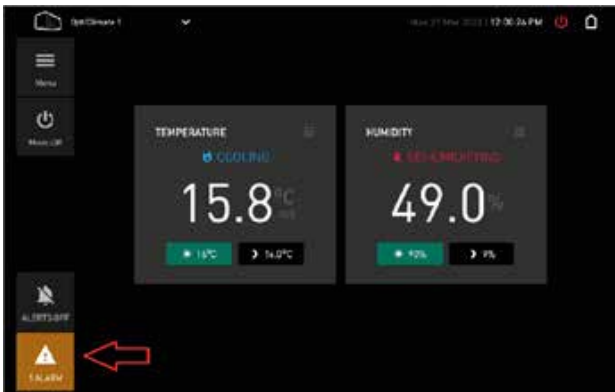

### Alarm

The ALARM icon will display an alarm (power failure) this is normal after startup and will show each time you power up the unit or in the case of a power failure. during initializing of the Opticlima. After powering up the Smart remote controller, the remote will first initialize, this can take a few minutes. You will see several screens pop-up and close again, this is normal.

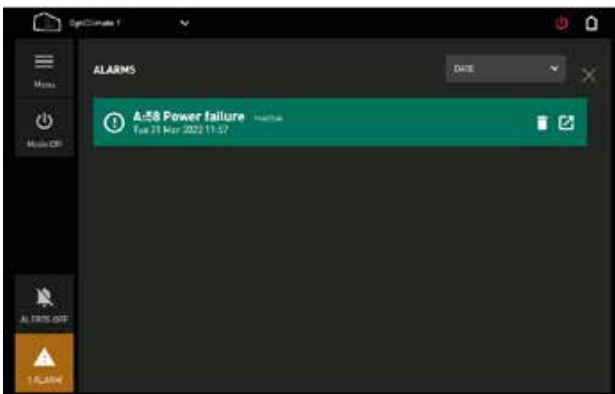

### Reading and deleting the alarm

You can obtain more information regarding this alarm by pushing on the "enlarge button".

You can erase the alarm by pushing on the alarm icon and then press the bin.

In the right upper corner you find the home icon you can toggle between home 1 (basic) and home 2 (advanced)

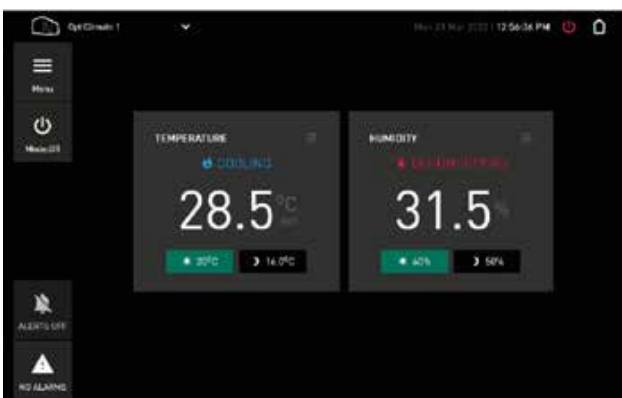

### Homescreen 1

You can obtain more information regarding this alarm by pushing on the "enlarge button".



### Homescreen 2

You can obtain more information regarding this alarm by pushing on the "enlarge button".

## OPERATING BY USING THE SMART REMOTE CONTROLLER

### Setting the basic parameters

Go to home 1 or home 2 by pressing the home icon.

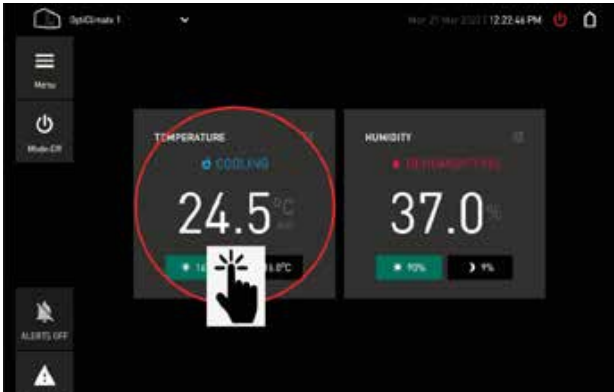

Touch the Temperature area to enlarge the window for temperature day/night settings.



#### Setting day temperature setpoint.

Touch the sun icon to set daymode temperature and use + and - to change the daymode temperature.



#### Setting night temperature setpoint.

Touch the moon icon to set nightmode temperature and use + and - to change the nightmode temperature.

Touch the X to return to home.

## OPERATING BY USING THE SMART REMOTE CONTROLLER

### Setting day and night dehumidify setpoint

Go to home 1 or home 2 by pressing the home icon.

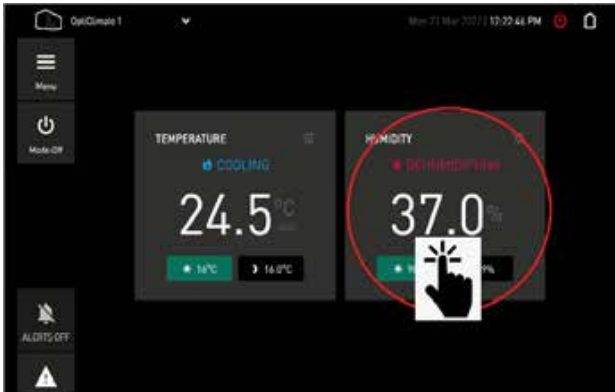

#### Setting day and night temperature setpoint.

Touch the dehumidify area to enlarge the window for dehumidify day/night settings.

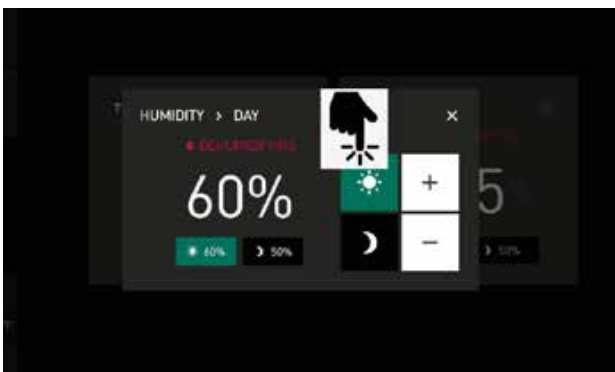

#### Setting day temperature setpoint.

Touch the sun icon to set daymode humidity and use + and - to change the daymode humidity setpoint.

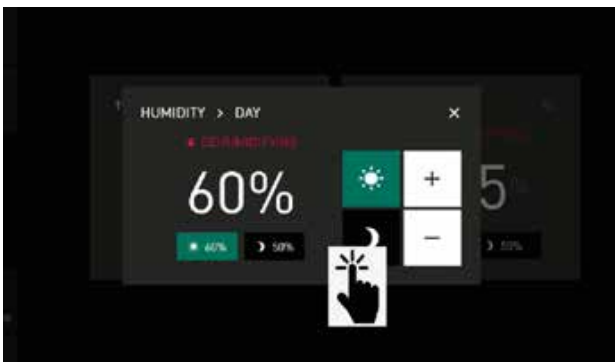

#### Setting night temperature setpoint.

Touch the moon icon to set nightmode humidity and use + and - to change the nightmode humidity setpoint.

Touch the X to return to home.

## OPERATING BY USING THE SMART REMOTE CONTROLLER

### On/off switch



#### Setting day and night temperature setpoint.

In the right upper corner you find the on/off button. Touching the button will switch the unit on and the icon turns green.

Touching the button again will turn the unit off and the icon will turn red.

#### Sequence of operation when the unit is turned on.

- The on/off button turns green
- The fan inside the unit turns on.
- The light sensor will determine if the room is in day or nightmode.

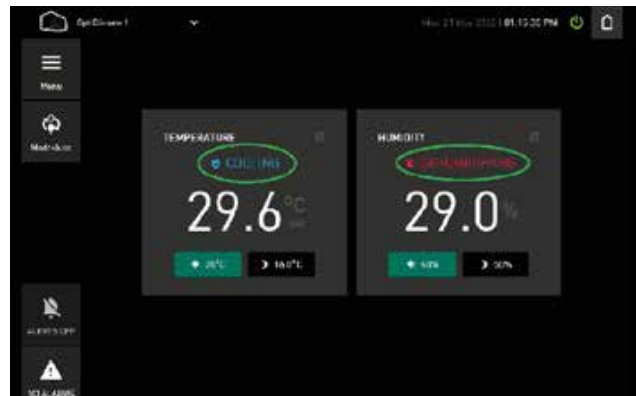
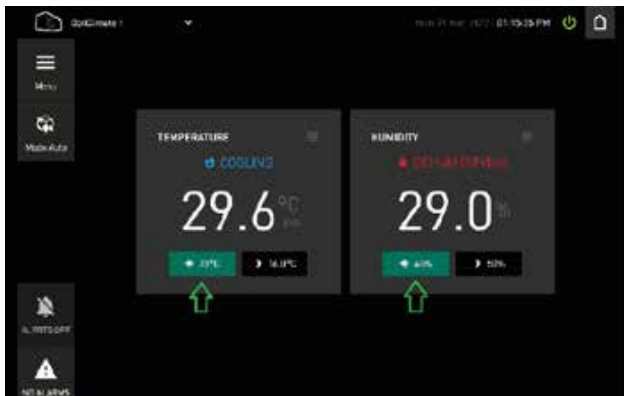

In daymode the windows with the sun turn green (night is black) and there will be an indication if the unit is cooling or not cooling and if there is a demand to dehumidify when not cooling. (Note: The unit always dehumidifies when cooling)

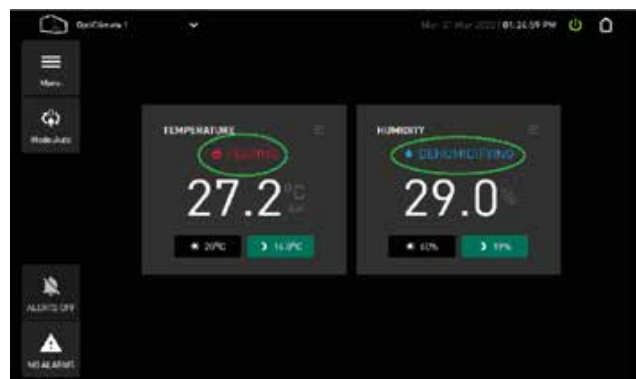

In nightmode the windows with the moon turn green (day is black) and there will be an indication if the unit is cooling or heating and if there is a demand to dehumidify when not cooling. (Note: The unit always dehumidifies when cooling)

## OPERATING BY USING THE SMART REMOTE CONTROLLER / ANYDESK

By touching the home button you can go to the advanced screen and you can see more parameters displayed and also a simple datalog window. The settings for temperature and humidity is the same as in the basic screen.

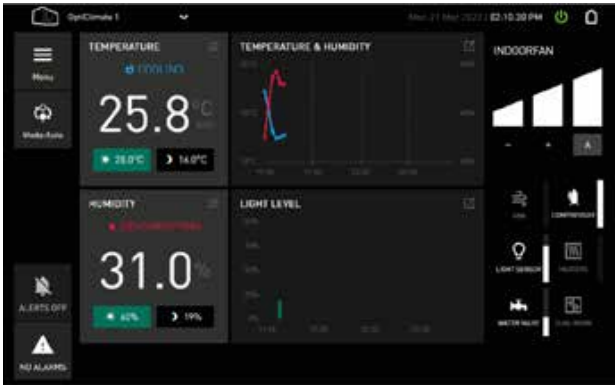

### Home - Advanced Screen

By touching the home button you can go to the advanced screen and you can see more parameters displayed and also a simple datalog window. The settings for temperature and humidity is the same as in the basic screen.

## Remote control via AnyDesk

The Revomax can be remotely controlled using any device connected to the internet. The remote controller uses the Anydesk application by default and you can access the unit using MIFI (modem using a sim card), Hotspot on a mobile cellphone, WIFI and LAN.

In a LAN setup, connect the LAN cable between the Smart Remote Controller and your modem or router. Connect the Smart Remote Controller to the network.



Go to Menu > Settings > User preferences > Remote Access

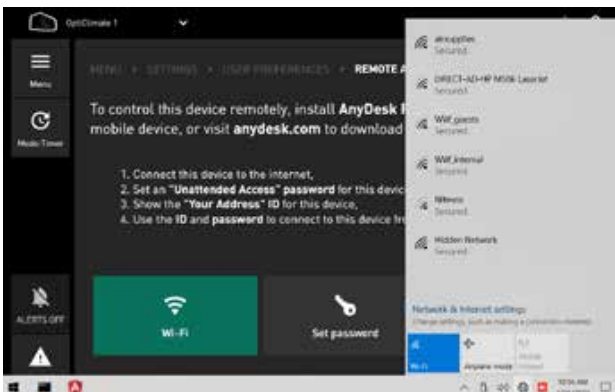

Tap "Wi-Fi" to open Network & Internet settings and connect to your internet access-point. You can skip this step if you use wired internet.

In a wireless setup (MIFI, Hotspot or MIFI) use the manual of the wireless device you are using and connect through Anydesk.

# REMOTE CONTROL VIA ANYDESK



Tap "Set password"



Click "Unlock Security Settings ..."



Tap the password field to open the on-screen keyboard. Unfortunately this obscures the password field, but that does not matter. Enter the password, which is either Maxi Controller for the smart remote controller with the golden startup logo or Revomax for the smart remote controller with the silver startup logo (the first letter must be uppercase). Press Enter **↵**, or close the keyboard and tap "Yes".

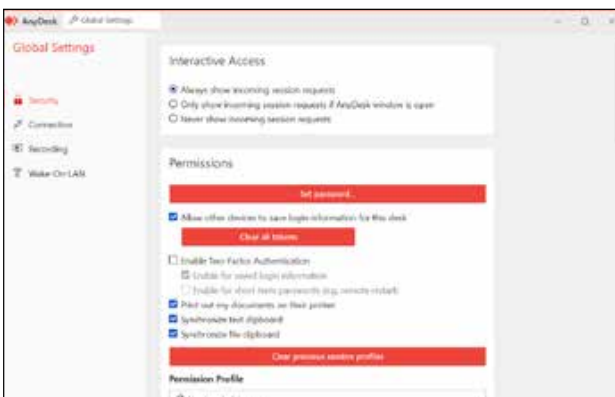

Tap "Set Password..."

# REMOTE CONTROL VIA ANYDESK

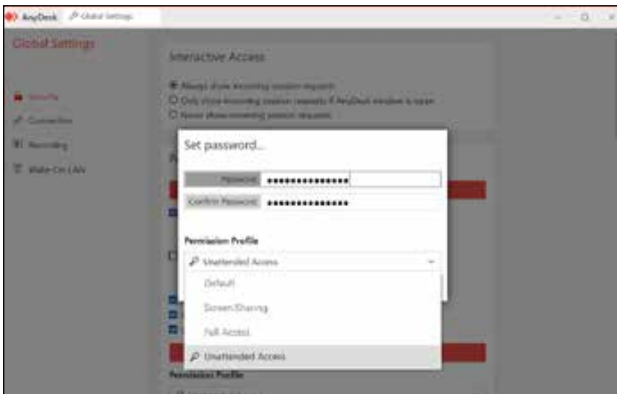

Enter the password you want to use to remotely access this controller in both fields and close the keyboard. Then tap on the "Permission Profile" box and change it to "Unattended Access" (This is important!)

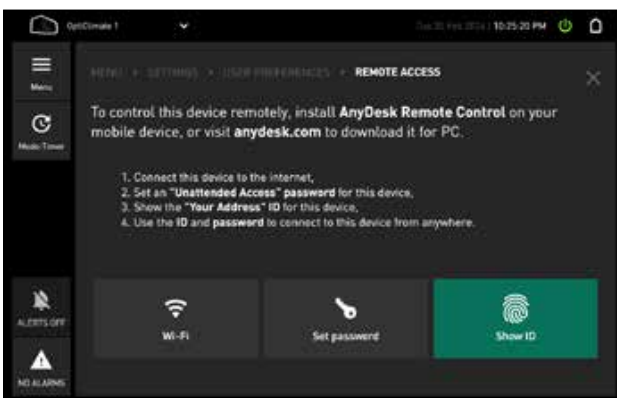

Close both the settings panels by tapping the cross in the top right, then tap "Show ID"



Enter this number into the AnyDesk client (installed in the previous section) and press connect. You can now close the AnyDesk panels on the controller.

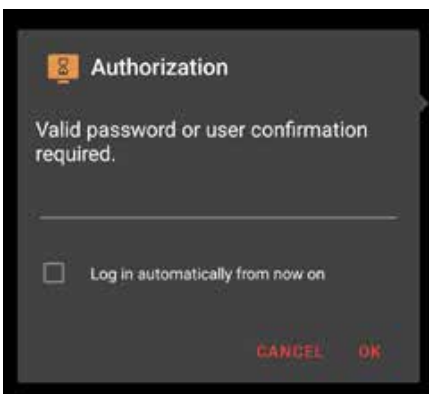

Use your AnyDesk client to test remote access to your controller now. It may take a minute before the connection succeeds.

If you get "Client Offline" you have mistyped the number or either your controller or AnyDesk client has lost internet connection. Do not attempt the option "Power On" as this has no effect.

## REMOTE CONTROL VIA ANYDESK



When connection succeeds, the controller shows the incoming connection. There's no need to press Accept on the controller; entering the password on the AnyDesk client will do the same. Your client will remember the 9-digit ID from now on.

### Additional accessories (sold separately)

#### Electric solenoid valve

The plug of the solenoid valve should be connected using the black cable supplied with the unit, as shown in the illustration below.



The other end of the cable is connected to the circuit board (see picture). The third connection of the solenoid valve can be used as earthing.

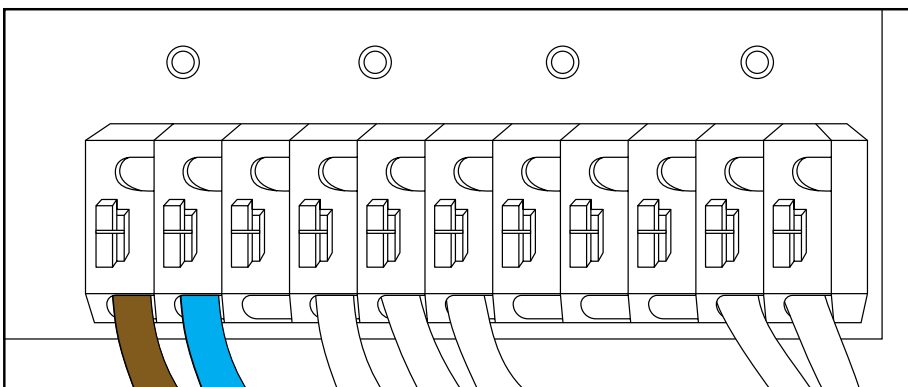



## ADDITIONAL ACCESSORIES

### Water leakage sensor

The connection set contains a loose, 5m long white wire: the water leakage sensor. This sensor is connected to the terminal on the printed circuit-board. The sensor cable should be led to the outside through the opening in the panel and should be placed on the ground at the lowest point. The end of the sensor cable can be split into several cores using a connector, so that more than one point is secured against leakage.

If the sensor has a black cap, this should be cut back and stripped 5mm and the cores should be stripped. Connect the other side to the little white plug on the printed circuit-board as shown in the illustration. In case of water leakage, the water supply will be stopped immediately by means of the electrical valve in the water pipe.

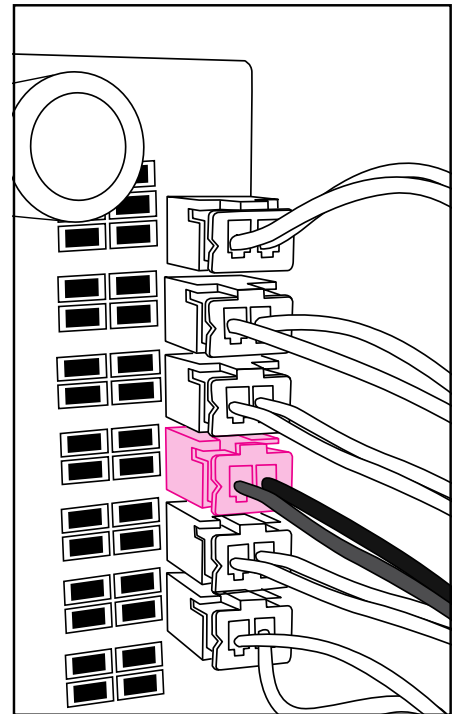



TheClimateFactory

[www.theclimatefactory.com](http://www.theclimatefactory.com)

# ZEVO MAX II

BY OPTICLIMATE

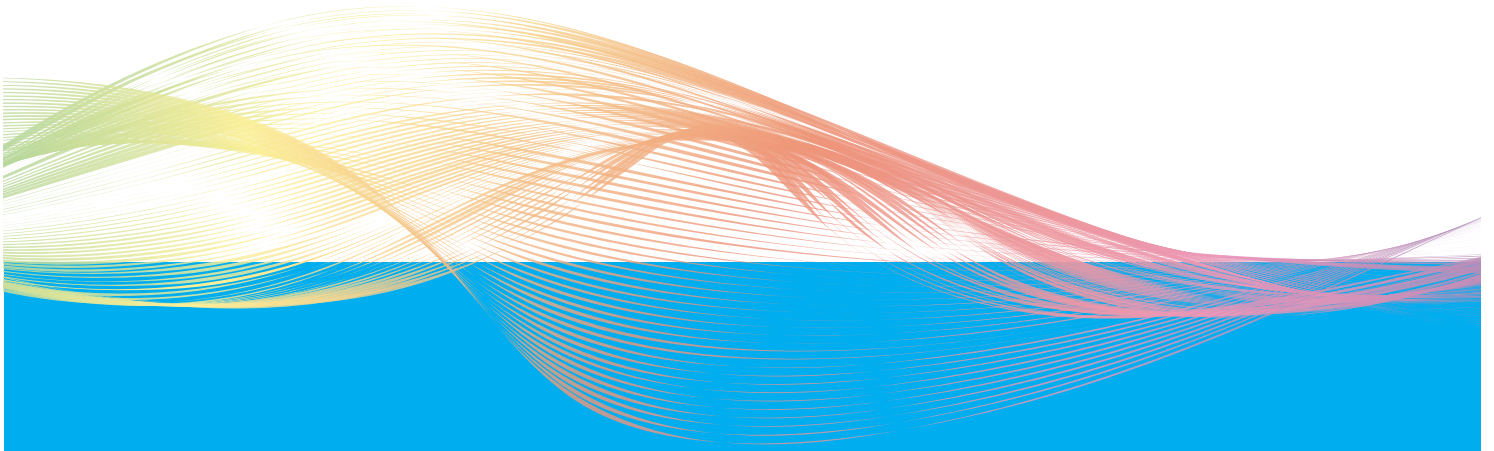

**INSTALLATION  
& USER GUIDE**

[www.theclimatefactory.com](http://www.theclimatefactory.com)

[info@theclimatefactory.com](mailto:info@theclimatefactory.com)