

OUTDOOR UNITS

MULTI VARIABLE SERIES

MODEL			MV-E14BI2	MV-E18BI2	MV-E21BI2	MV-E24BI2	
Qty of connectable indoor units			1-2	1-2	2-3	2-3	
Capacity cooling / heating 1)	Nominal (min-max)	kW	4,1 (2,1-4,4) / 4,4 (2,5-5,4)	5,3 (2,1-5,8) / 5,7 (2,6-6,0)	6,1 (2,2-7,3) / 6,5 (3,6-8,5)	7,1 (2,3-8,5) / 8,6 (3,7-8,8)	
Power supply		Hz / V	1~ / 50 / 220-240	1~ / 50 / 220-240	1~ / 50 / 220-240	1~ / 50 / 220-240	
Power input cooling / heating 1)		W	1100 / 970	1480 / 1250	1480 / 1430	1880 / 2230	
Maximal power input 2)		W	2250	2500	2900	3400	
Power current cooling / heating		A	4,9 / 4,4	6,6 / 5,6	6,6 / 6,3	8,4 / 9,9	
Maximal power current 2)		A	10,0	11,0	12,9	14,6	
Energy class cooling 3)			-	-	-	-	
Air flow of OD	H	m ³ / h	2300	2300	3800	3800	
Sound pressure level of OD at 1m 4)	H	dB(A)	52	54	58	58	
Sound power of OD 4)	H	dB(A)	62	64	68	68	
Refrigerant type / charge		Type / kg / t eq. CO ₂	R32 / 0,75 / 0,51	R32 / 0,90 / 0,60	R32 / 1,60 / 1,08	R32 / 1,70 / 1,14	
Additional refrigerant		g / m	20	20	20	20	
Pipe diameter - liquid side 5)		qty x mm	2 x 6,0	2 x 6,0	3 x 6,0	3 x 6,0	
Pipe diameter - gas side 5)		qty x mm	2 x 9,5	2 x 9,5	3 x 9,5	3 x 9,5	
Max pipe length without additional refrigerant 6)		m	10	10	30	30	
Maximal pipe length to 1 indoor unit 9)		m	20	20	20	20	
Maximal total pipe length 7)		m	40	40	60	60	
Max. elevation / Drop height		m	15	15	15	15	
Dimension of OD	w x h x d	mm	822 x 550 x 352	822 x 550 x 352	964 x 660 x 402	964 x 660 x 402	
Package dimension of OD	w x h x d	mm	872 x 620 x 398	872 x 620 x 398	1032 x 737 x 456	1032 x 737 x 456	
Weight of OD	netto / brutto	kg	30,0 / 32,5	32,0 / 34,5	47,5 / 52,0	47,5 / 52,0	
Operating temperature range (cooling) 8)	Cooling	°C	-15-43	-15-43	-15-43	-15-43	
Operating temperature range (heating) 8)	Heating	°C	-22-24	-22-24	-22-24	-22-24	
ADDITIONAL TECHNICAL INFORMATION							
Screw holes distance of OD	w x d	mm	512 x 332	512 x 332	570 x 371	570 x 371	
Communication cable		mm ²	4-wire cable *				
Recommended power cable		mm ²	3 x 1,5	3 x 1,5	3 x 2,5	3 x 2,5	
Recommended air switch		A	13	13	16	16	
EQUIPMENT							
Throttling method			EXV	EXV	EXV	EXV	
Bottom chassis heater			Heating belt	Heating belt	Heating belt	Heating belt	
Crankcase heater			✓	✓	✓	✓	
Bottom plugs for OD			✓	✓	✓	✓	
Drain pipe connector			✓	✓	✓	✓	
Pipe reduction			✓	✓	✓	✓	

The specification of products is subject to change based on further development of the units by the producer and can be changed without prior notice. Refer to rating label.

R32 (single component refrigerant HFC), GWP of refrigerant used: 675.

Contains fluorinated greenhouse gases covered by the Kyoto Protocol.

Explanatory notes on the very last page of the catalogue.

May not be used separately, must be combined with indoor units from Multi Variable (MV) series.

* Cross-section of each wire must correspond to the IEC 60364

APPEARANCE AND DIMENSIONS OF INDOOR UNIT

MV-E14BI2, MV-E18BI2

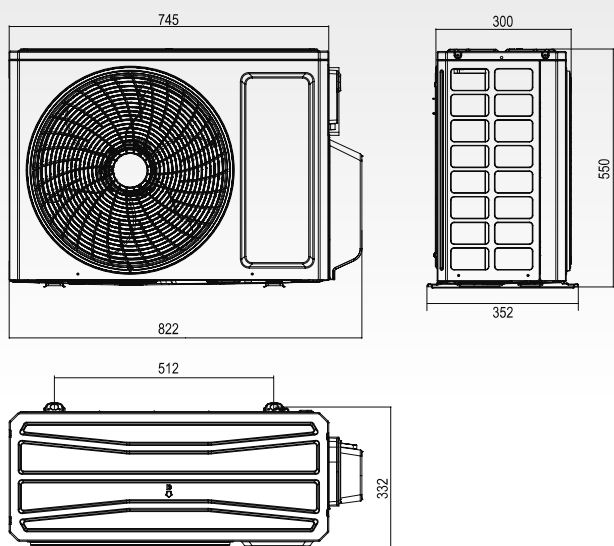

MV-E21BI2, MV-E24BI2

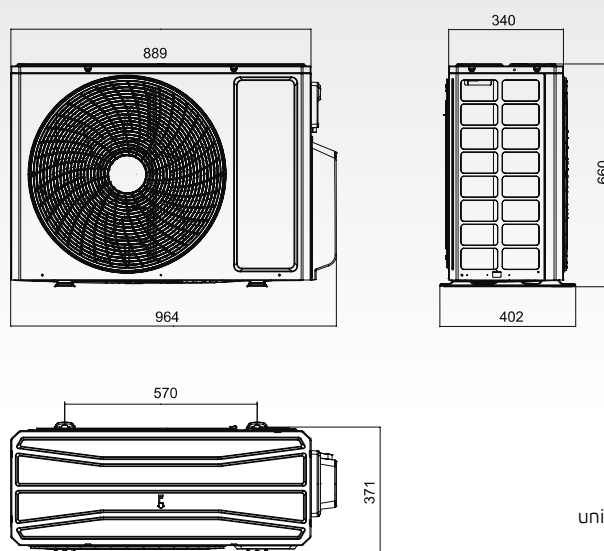

units: mm