

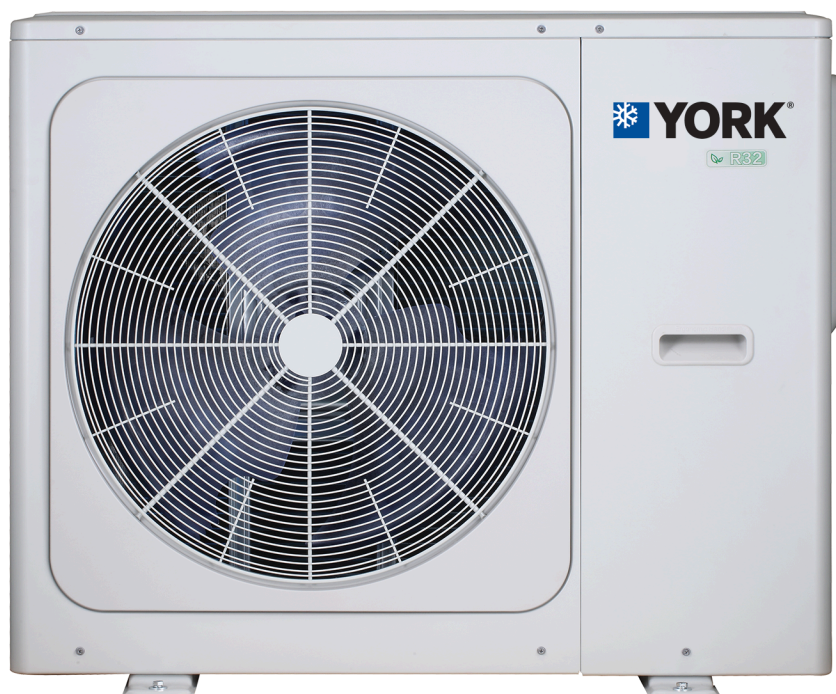

YKF Air Source Heat Pump System

Monoblock Single and Triphase, 5 kW to 16 kW



Installation, Commissioning, Operation, and Maintenance Form: 201.55-ICOM1.EN.CE (922)

Issue date: 2022-09-01

Supersedes: 201.55-ICOM1.EN.CE (622)



CONTENTS

1	SAFETY PRECAUTIONS	02
2	GENERAL INTRODUCTION	05
3	ACCESSORIES	06
	• 3.1 Accessories supplied with the unit	06
	• 3.2 Accessories available from supplier	06
4	BEFORE INSTALLATION	07
5	IMPORTANT INFORMATION FOR THE REFRIGERANT	07
6	INSTALLATION SITE	08
	• 6.1 Selecting a location in cold climates	09
	• 6.2 Selecting a location in direct sunlight	09
7	INSTALLATION PRECAUTIONS	10
	• 7.1 Dimensions	10
	• 7.2 Installation requirements	10
	• 7.3 Drain hole position	11
	• 7.4 Servicing space requirements	11
8	TYPICAL APPLICATIONS	13
	• 8.1 Application 1	13
	• 8.2 Application 2	15
	• 8.3 Cascade system	18
	• 8.4 Buffer tank volume requirement	20
9	OVERVIEW OF THE UNIT	20
	• 9.1 Main components	20
	• 9.2 Control board	21
	• 9.3 Water piping	26
	• 9.4 Filling water	29
	• 9.5 Water piping insulation	30
	• 9.6 Field wiring	30
10	START-UP AND CONFIGURATION	43
	• 10.1 Initial start-up at low outdoor ambient temperature	43
	• 10.2 Pre-operation checks	43
	• 10.3 Failure diagnosis at first installation	43
	• 10.4 Installation Manual	43
	• 10.5 Field settings	45

11 MENU STRUCTURE: OVERVIEW	46
• 11.1 Setting parameters	48
12 FINAL CHECKS AND TEST RUN	52
• 12.1 Final checks	52
• 12.2 Test run operation(manually)	52
13 MAINTENANCE AND SERVICE	53
14 TROUBLESHOOTING	54
• 14.1 General guidelines	54
• 14.2 General symptoms	55
• 14.3 Error codes	57
15 TECHNICAL SPECIFICATIONS	59
• 15.1 General	59
• 15.2 Electrical specifications	59
16 INFORMATION SERVICING	60

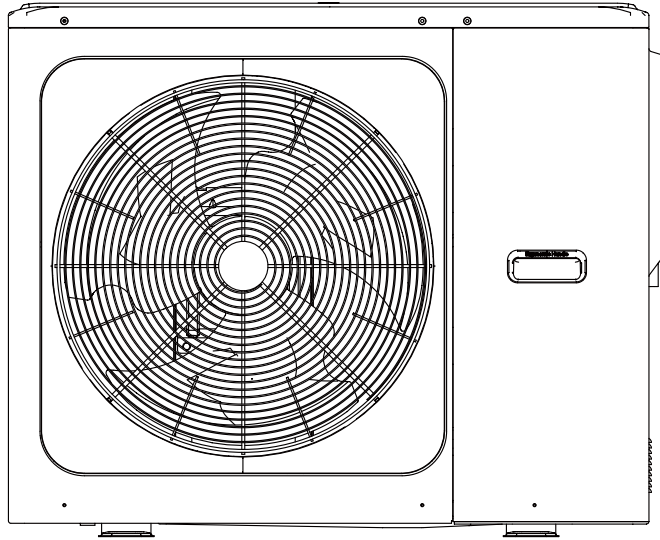

Please remove the hollow plate after installation.

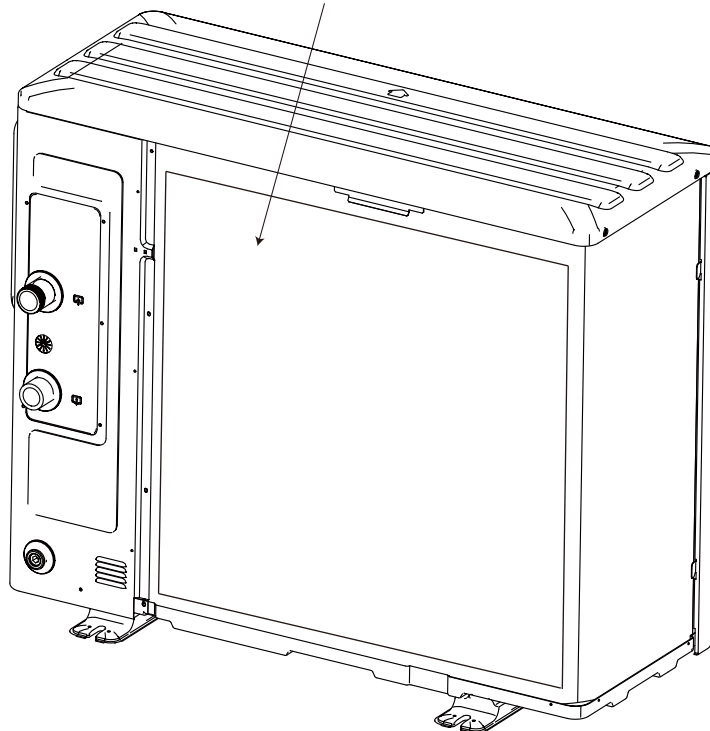

NOTE

- Pictures in this manual are for reference only, please refer to the actual product.
- The backup heater can be customized outside the unit based on user needs. The options are: 3kW (1-phase), 4.5kW (1-phase), 4.5kW (3-phase), 6kW (3-phase) and 9kW (3-phase). Please refer to the INSTALLATION & OWNER'S MANUAL of the backup heater for details.
- The backup heater (optional) and heat pump are independently powered.

1 SAFETY PRECAUTIONS

The precautions listed here are divided into the following types. They are important, so be sure to follow them carefully.

Meanings of DANGER, WARNING, CAUTION and NOTE symbols.

INFORMATION

- Read these instructions carefully before installation. Keep this manual in a convenient location for future reference.
- Incorrect installation of equipment or accessories may result in electric shock, short-circuit, leakage, fire or other damage to the equipment. Be sure to only use accessories made by the supplier, which are specifically designed for the equipment and make sure to get installation done by a professional.
- All the activities described in this manual must be carried out by a licensed technician. Be sure to wear adequate personal protection equipment such as gloves and safety glasses while installing the unit or carrying out maintenance activities.
- Contact your dealer for any further assistance.



Caution: Risk of fire/
flammable materials

WARNING

Servicing shall only be performed as recommended by the equipment manufacturer. Maintenance and repair requiring the assistance of other skilled personnel shall be carried out under the supervision of the person competent in the use of flammable refrigerants.

DANGER

Indicates an imminently hazardous situation which if not avoided, will result in death or serious injury.

WARNING

Indicates a potentially hazardous situation which if not avoided, could result in death or serious injury.





CAUTION

Indicates a potentially hazardous situation which if not avoided, may result in minor or moderate injury. It is also used to alert against unsafe practices.

NOTE

Indicates situations that could only result in accidental equipment or property damage.

Explanation of symbols displayed on the unit

	WARNING	This symbol shows that this appliance used a flammable refrigerant. If the refrigerant is leaked and exposed to an external ignition source, there is a risk of fire.
	CAUTION	This symbol shows that the operation manual should be read carefully.
	CAUTION	This symbol shows that a service personnel should be handling this equipment with reference to the installation manual.
	CAUTION	This symbol shows that information is available such as the operating manual or installation manual.

DANGER

- Before touching electric terminal parts, turn off power switch.
- When service panels are removed, live parts can be easily touched by accident.
- Never leave the unit unattended during installation or servicing when the service panel is removed.
- Do not touch water pipes during and immediately after operation as the pipes may be hot and could burn your hands. To avoid injury, give the piping time to return to normal temperature or be sure to wear protective gloves.
- Do not touch any switch with wet fingers. Touching a switch with wet fingers can cause an electric shock.
- Before touching electrical parts, turn off all applicable power to the unit.

WARNING

- Tear apart and throw away plastic packaging bags so that children will not play with them. Children playing with plastic bags face danger of death by suffocation.
- Safely dispose of packing materials such as nails and other metal or wood parts that could cause injuries.
- Ask your dealer or qualified personnel to perform installation work in accordance with this manual. Do not install the unit yourself. Improper installation could result in water leakage, electric shocks or fire.
- Be sure to use only specified accessories and parts for installation work. Failure to use specified parts may result in water leakage, electric shocks, fire, or the unit falling from its mount.
- Install the unit on a foundation that can withstand its weight. Insufficient physical strength may cause the equipment to fall and potentially cause injuries.
- Perform specified installation work with full consideration of strong wind, hurricanes, or earthquakes. Improper installation work may result in accidents due to equipment falling.
- Make certain that all electrical work is carried out by qualified personnel according to the local laws and regulations and this manual using a separate circuit. Insufficient capacity of the power supply circuit or improper electrical construction may lead to electric shocks or fire.
- Be sure to install a ground fault circuit interrupter according to local laws and regulations. Failure to install a ground fault circuit interrupter may cause electric shocks and fire.
- Make sure all wiring is secure. Use the specified wires and ensure that terminal connections or wires are protected from water and other adverse external forces. Incomplete connection or affixing may cause a fire.
- When wiring the power supply, form the wires so that the front panel can be securely fastened. If the front panel is not in place the terminals could overheat, or there could be electric shocks or a fire.
- After completing the installation work, check to make sure that there is no refrigerant leakage.
- Never directly touch any leaking refrigerant as it could cause severe frostbite. Do not touch the refrigerant pipes during and immediately after operation as the refrigerant pipes may be hot or cold, depending on the condition of the refrigerant flowing through the refrigerant piping, compressor and other refrigerant cycle parts. Burns or frostbite are possible if you touch the refrigerant pipes. To avoid injury, give the pipes time to return to normal temperature or, if you must touch them, be sure to wear protective gloves.
- Do not touch the internal parts (pump, backup heater, etc.) during and immediately after operation. Touching the internal parts can cause burns. To avoid injury, give the internal parts time to return to normal temperature or, if you must touch them, be sure to wear protective gloves.

CAUTION

- Ground the unit.
- Grounding resistance should be according to local laws and regulations.
- Do not connect the ground wire to gas or water pipes, lightning conductors or telephone ground wires.
- Incomplete grounding may cause electric shocks.
 - Gas pipes: Fire or an explosion might occur if the gas leaks.
 - Water pipes: Hard vinyl tubes are not effective grounds.
 - Lightning conductors or telephone ground wires: Electrical threshold may rise abnormally if struck by a lightning bolt.
- Install the power wire at least 3 feet (1 meter) away from televisions or radios to prevent interference or noise. (Depending on the radio waves, a distance of 3 feet (1 meter) may not be sufficient to eliminate the noise.)
- Do not wash the unit. This may cause electric shocks or fire. The appliance must be installed in accordance with national wiring regulations. If the supply cord is damaged, it must be replaced by the manufacturer, its service agent or similarly qualified persons in order to avoid a hazard.

- Do not install the unit in the following places:
 - Where there is mist of mineral oil, oil spray or vapors. Plastic parts may deteriorate, and cause them to come loose or water to leak.
 - Where corrosive gases (such as sulphurous acid gas) are produced. Where corrosion of copper pipes or soldered parts may cause refrigerant to leak.
 - Where there is machinery which emits electromagnetic waves. Electromagnetic waves can disturb the control system and cause equipment malfunction.
 - Where flammable gases may leak, where carbon fiber or ignitable dust is suspended in the air or where volatile flammables such as paint thinner or gasoline are handled. These types of gases might cause a fire.
 - Where the air contains high levels of salt such as near the ocean.
 - Where voltage fluctuates a lot, such as in factories.
 - In vehicles or vessels.
 - Where acidic or alkaline vapors are present.
- This appliance can be used by children 8 years old and above and persons with reduced physical, sensory or mental capabilities or lack of experience and knowledge if they are supervised or given instruction on using the unit in a safe manner and understand the hazards involved. Children should not play with the unit. Cleaning and user maintenance should not be done by children without supervision.
- Children should be supervised to ensure that they do not play with the appliance.
- If the supply cord is damaged, it must be replaced by the manufacturer or its service agent or a similarly qualified person.
- DISPOSAL: Do not dispose of this product as unsorted municipal waste. Special waste treatment is necessary for this product. Do not dispose of electrical appliances as municipal waste, use separate collection facilities. Contact your local government for information regarding the collection systems available. If electrical appliances are disposed of in landfills or dumps, hazardous substance can leak into the groundwater and get into the food chain, damaging your health and well-being.
- The wiring must be performed by professional technicians in accordance with national wiring regulation and the supplied circuit diagram. An all-pole disconnection device which has at least 3mm separation distance in all poles and a residual current device (RCD) with the rating not exceeding 30mA shall be incorporated in the fixed wiring according to the national rule.
- Confirm the safety of the installation area (walls, floors, etc.) without hidden dangers such as water, electricity, and gas. Before wiring/pipes.
- Before installation , check whether the user's power supply meets the electrical installation requirements of the unit (including reliable grounding, leakage, and wire diameter electrical load, etc.). If the electrical installation requirements of the product are not met, the installation of the product is prohibited until the issue is rectified.
- When installing multiple air conditioners in a centralized manner, please confirm the load balance of the three-phase power supply, and multiple units are prevented from being assembled into the same phase of the three-phase power supply.
- During product installation, fix the product firmly in place. Take reinforcement measures, when necessary.

💡 NOTE

- About Fluorinated Gasses
 - This air-conditioning unit contains fluorinated gasses. For specific information on the type of gas and the amount, please refer to the relevant label on the unit itself. Compliance with national gas regulations shall be observed.
 - Installation, service, maintenance and repair of this unit must be performed by a certified technician.
 - Product uninstallation and recycling must be performed by a certified technician.
 - If the system has a leak-detection system installed, it must be checked for leaks at least every 12 months. When the unit is checked for leaks, proper record-keeping of all checks is strongly recommended.

2 GENERAL INTRODUCTION

- These units are used for both heating and cooling applications and domestic hot water tanks. They can be combined with fan coil units, floor heating applications, low temperature high efficiency radiators, domestic hot water tanks and solar kits, which are all field supplied.
- A wired controller is supplied with the unit .
- The backup heater (optional) can increase the heating capacity at low outdoor temperature. It also serves as a backup service in case of malfunction of the heat pump and to avoid freezing of outdoor water pipes.

NOTE

- Maximum length of communication wirings between the unit and the controller is 50m.
- Power cords and communication wiring must be laid out separately, they can not be placed in the same conduit. Otherwise, it may lead to electromagnetic interference. Power cords and communication wirings should not come in contact with the refrigerant pipe to prevent the high temperature pipe from damaging wirings.
- Communication wirings must use shielded lines. Including indoor unit to outdoor unit PQE line ,indoor unit to controller HA and HB line.

The relationship between capacity (Load) and ambient temperature

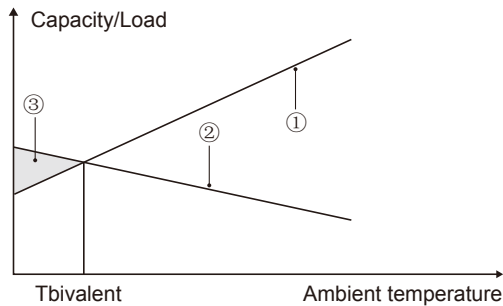

- ① Heat pump capacity.
- ② Required heating capacity (site dependent).
- ③ Additional heating capacity provided by backup heater.

Domestic hot water tank (field supply)

A domestic hot water tank (with or without booster heater) can be connected to the unit.

The requirement of the tank is different for different units and material of heat exchanger.

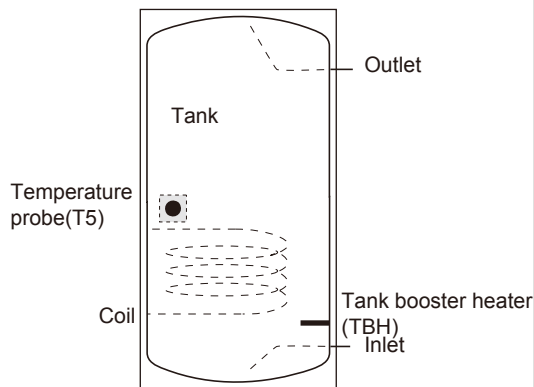

The booster heater should be installed below the temperature probe (T5).

The heat exchanger (coil) should be installed below the temperature probe.

The pipe length between the outdoor unit and tank should be less than 5 meters.

Model		5kW	7~9kW	12~16kW
Volume of tank/L	Recommended	100~250	150~300	200~500
Heat exchange area/m ² (Stainless steel coil)	Minimum	1.4	1.4	1.6
Heat exchange area/m ² (Enamel coil)	Minimum	2.0	2.0	2.5

Room thermostat (field supplied)

Room thermostat can be connected to the unit (room thermostat should be kept away from heating source when selecting the installation place).

Solar kit for domestic hot water tank (field supplied)

An optional solar kit can be connected to the unit.

Operation range

Outlet water (Heating mode)	+15 ~ +65 °C	
Outlet water (Cooling mode)	+5 ~ +25 °C	
Domestic hot water	+15~ +60 °C	
Ambient temperature	-25 ~ +43 °C	
Water pressure	0.1~0.3MPa	
Water flow	5kW	0.40~1.25m ³ /h
	7kW	0.40~1.65m ³ /h
	9kW	0.40~2.10m ³ /h
	12kW	0.70~2.50m ³ /h
	14kW	0.70~2.75m ³ /h
	16kW	0.70~3.00m ³ /h

In cooling mode, the water flowing temperature (TW_out) range in different outdoor temperatures (T4) is listed below:

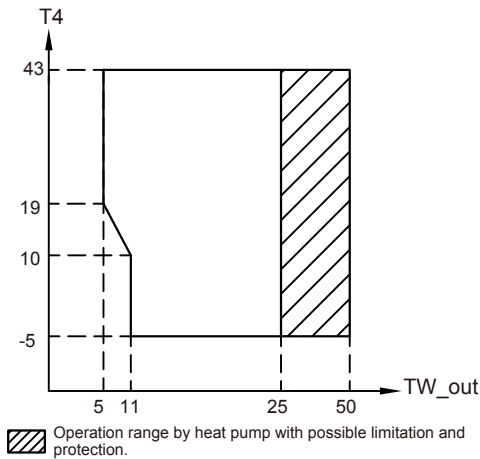

In heating mode, the water flowing temperature (T1) range in different outdoor temperatures (T4) are listed below:

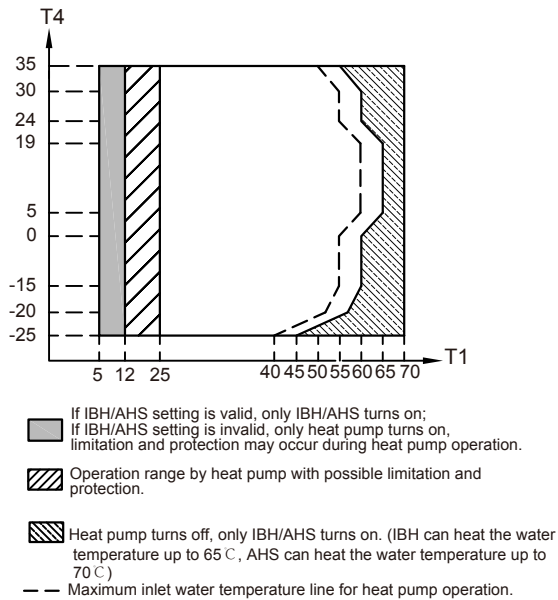



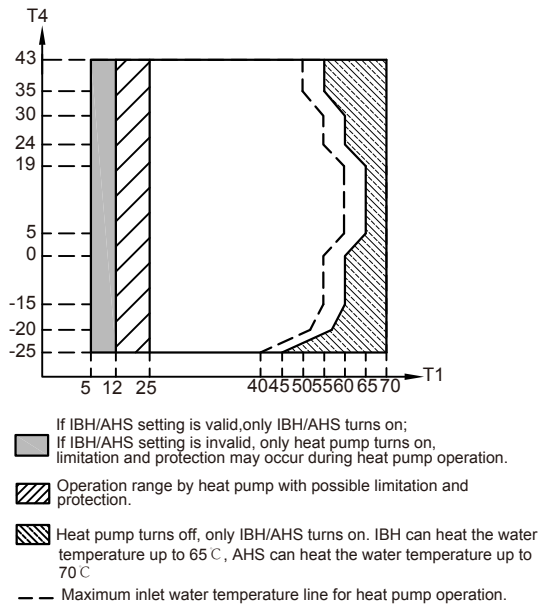





In DHW mode, the water flowing temperature(T1) range in different outdoor temperatures (T4) is listed below:







3 ACCESSORIES

3.1 Accessories supplied with the unit

Installation Fittings		
Name	Shape	Quantity
Installation and owner's manual (this book)		1
Technical data manual		1
Y-shape filter		1
Wired controller		1
Thermistor(10m) for Tbt (or Tw2 or Tsolar or T5)		1
Drain hose		1
Energy label		1
Network matching wires		1
Protect Angle		1

3.2 Accessories available from supplier

Thermistor for buffer tank temp.(Tbt)	
Connection wiring of Tbt sensor	
Thermistor for Zone 2 flow temp.(Tw2)	
Thermistor for solar temp.(Tsolar)	
Thermistor for hot water tank temp.(T5)	

Thermistor for Tbt,Tw2,Tsolar and T5 can be shared. If necessary, you can purchase other thermistors and connection wiring from the supplier.

4 BEFORE INSTALLATION

- **Before installation**

Be sure to confirm the model name and the serial number of the unit.

- **Transport**

Due to relatively large dimensions and heavy weight, the unit should only be hoisted by lifting tools with slings, please refer to the following picture.

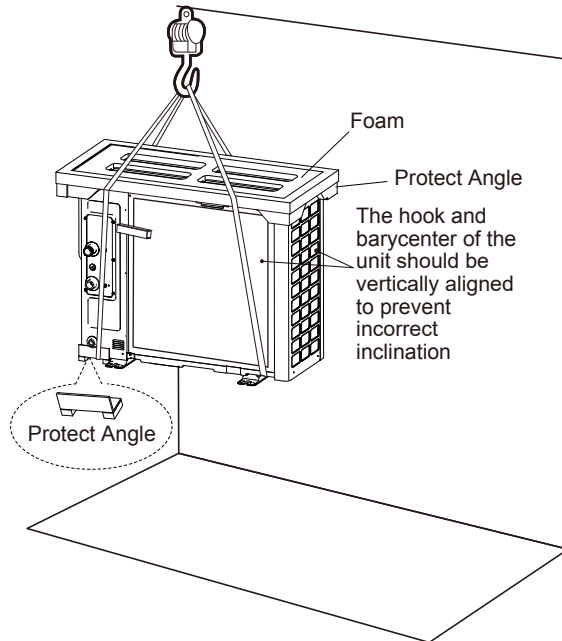

⚠ CAUTION

- To avoid injury, do not touch the air inlet or aluminum fins of the unit.
- Do not use the grips in the fan grills to avoid damage.
- The unit is top heavy! Prevent the unit from falling due to improper inclination during handling.

(unit:mm)

Model	A	B	C
1 phase 5/7/9kW	350	355	285
1 phase 12/14/16kW	540	390	255
3 phase 12/14/16kW	500	400	275

The position of barycenter for different units can be seen in the picture below.

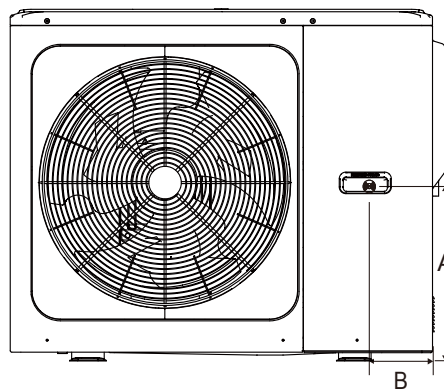
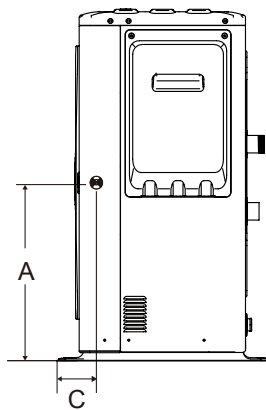

5 IMPORTANT INFORMATION FOR THE REFRIGERANT

This product has the fluorinated gas, which is forbidden to release to air.

Refrigerant type: R32; Volume of GWP: 675.

GWP=Global Warming Potential

Model	Factory charged refrigerant volume in the unit	
	Refrigerant/kg	Tonnes CO ₂ equivalent
5kW	1.25	0.85
7kW	1.25	0.85
9kW	1.25	0.85
12kW	1.80	1.22
14kW	1.80	1.22
16kW	1.80	1.22

CAUTION

- Frequency of Refrigerant Leakage Checks
 - For units that contain fluorinated greenhouse gases in quantities of 5 tonnes of CO₂ equivalent or more, but of less than 50 tonnes of CO₂ equivalent, at least every 12 months, or where a leakage detection system is installed, at least every 24 months.
 - For units that contain fluorinated greenhouse gases in quantities of 50 tonnes of CO₂ equivalent or more, but of less than 500 tonnes of CO₂ equivalent, at least every six months, or where a leakage detection system is installed, at least every 12 months.
 - For units that contain fluorinated greenhouse gases in quantities of 500 tonnes of CO₂ equivalent or more, at least every three months, or where a leakage detection system is installed, at least every six months.
- This air-conditioning unit is a hermetically sealed equipment that contains fluorinated greenhouse gases.
- Only certificated personnel are allowed to do installation, operation and maintenance.

6 INSTALLATION SITE

WARNING

- There is flammable refrigerant in the unit and it should be installed in a well-ventilated site. If the unit is installed inside, an additional refrigerant detection device and ventilation equipment must be added in accordance with the standard EN378. Be sure to adopt adequate measures to prevent the unit from being used as a shelter by small animals.
 - Small animals making contact with electrical parts can cause malfunction, smoke or fire. Please instruct the customer to keep the area around the unit clean.
-
- Select an installation site where the following conditions are satisfied and one that meets with your customer's approval.
 - Places that are well-ventilated.
 - Places where the unit does not disturb neighbors.
 - Safe places which can bear the unit's weight and vibration and where the unit can be installed at an even level.
 - Places where there is no possibility of flammable gas or product leak.
 - The equipment is not intended for use in a potentially explosive atmosphere.
 - Places where servicing space can be well ensured.
 - Places where the units' piping and wiring lengths come within the allowable ranges.
 - Places where water leaking from the unit cannot cause damage to the location (e.g. in case of a blocked drain pipe).
 - Places where rain can be avoided as much as possible.
 - Do not install the unit in places often used as a work space. In case of construction work (e.g. grinding etc.) where a lot of dust is created, the unit must be covered.
 - Do not place any object or equipment on top of the unit (top plate).
 - Do not climb, sit or stand on top of the unit.
 - Be sure that sufficient precautions are taken in case of refrigerant leakage according to relevant local laws and regulations.
 - Don't install the unit near the sea or where there is corrosion gas.
 - When installing the unit in a place exposed to strong wind, pay special attention to the following.
 - Strong winds of 5 m/sec or more blowing against the unit's air outlet causes a short circuit (suction of discharge air), and this may have the following consequences:
 - Deterioration of the operational capacity.
 - Frequent frost acceleration in heating operation.
 - Disruption of operation due to rise of high pressure.
 - When a strong wind blows continuously on the front of the unit, the fan can start rotating very fast until it breaks.

In normal conditions, refer to the figures below for installation of the unit:

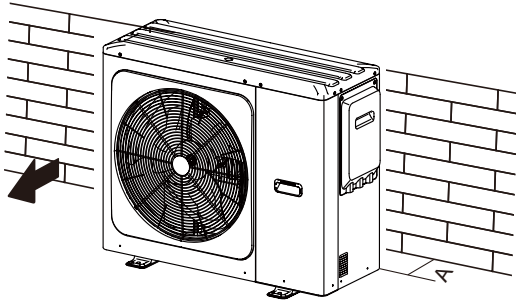

Unit	A(mm)
5~16kW	≥300

In case of strong wind and the wind direction can be foreseen, refer to the figures below for installation of the unit (any one is OK):

Turn the air outlet side toward the building's wall, fence or screen.

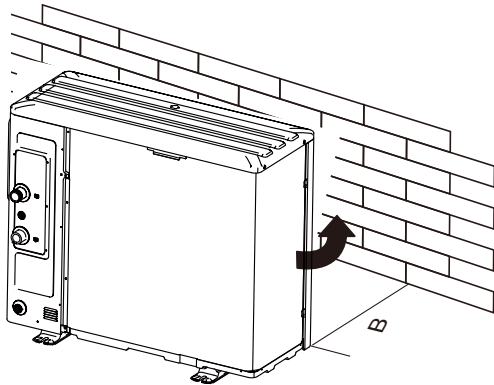

Unit	B(mm)
5~9kW	≥1000
12~16kW	≥1500

Make sure there is enough space to install the unit.

Set the outlet side at a right angle to the direction of the wind.

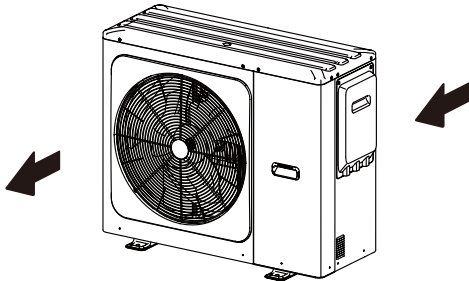

- Prepare a water drainage channel around the foundation, to drain waste water from around the unit.
- If water does not easily drain from the unit, mount the unit on a foundation of concrete blocks, etc. (The height of the foundation should be about 100 mm (3.93 in)).
- If you install the unit on a frame, please install a waterproof plate (about 100 mm) on the underside of the unit to prevent water from coming in from the low side.
- When installing the unit in a place frequently exposed to snow, pay special attention to elevate the foundation as high as possible.

- If you install the unit on a building frame, please install a waterproof tray (field supply) (about 100mm, on the underside of the unit) in order to avoid drain water dripping. (See the picture in the right).



6.1 Selecting a location in cold climates

Refer to "Handling" in section "4 BEFORE INSTALLATION"

NOTE

When operating the unit in cold climates, be sure to follow the instructions described below.

- To prevent exposure to wind, install the unit with its suction side facing the wall.
- Never install the unit at a site where the suction side may be exposed directly to wind.
- To prevent exposure to wind, install a baffle plate on the air discharge side of the unit.
- In heavy snowfall areas, it is very important to select an installation site where the snow will not affect the unit. If lateral snowfall is possible, make sure that the heat exchanger coil is not affected by the snow (if necessary construct a lateral canopy).

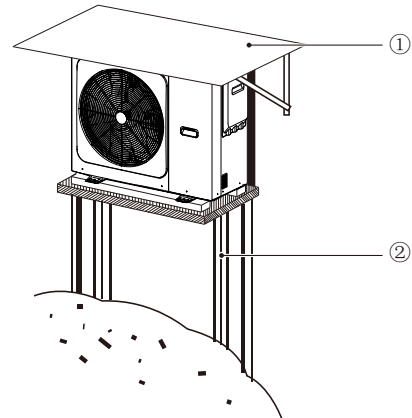

① Construct a large canopy.

② Construct a pedestal.

Install the unit high enough off the ground to prevent it from being buried in snow. (The height of the pedestal must be larger than the largest thickness of the snow in the local history plus 10cm or more)

6.2 Selecting a location in direct sunlight

As the outdoor temperature is measured via the unit's ambient temperature sensor, make sure to install the unit in the shade or under a canopy to avoid direct sunlight, so that it is not influenced by the sun's heat. If this is not possible, protect the unit accordingly.

7 INSTALLATION PRECAUTIONS

7.1 Dimensions

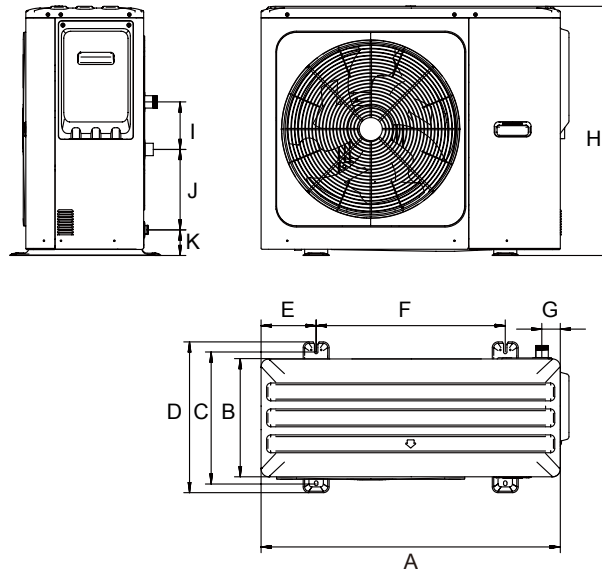

(unit:mm)

Model	A	B	C	D	E	F	G	H	I	J	K
5-16kW	1040	410	458	523	191	656	64	865	165	279	89

7.2 Installation requirements

- Check the strength and level of the installation ground so that the unit will not cause any vibrations or noise during its operation.
- In accordance with the foundation drawing in the figure, fix the unit securely by means of foundation bolts. Prepare four sets each of $\Phi 10$ Expansion bolts, nuts and washers which are readily available in the market.
- Screw in the foundation bolts until their length is 20 mm from the foundation surface.

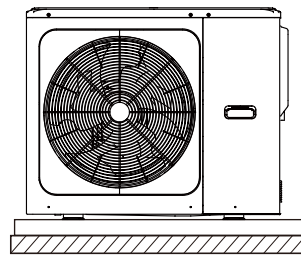
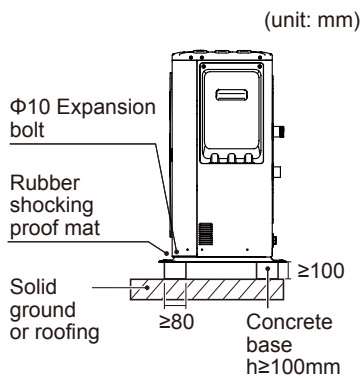

7.3 Drain hole position

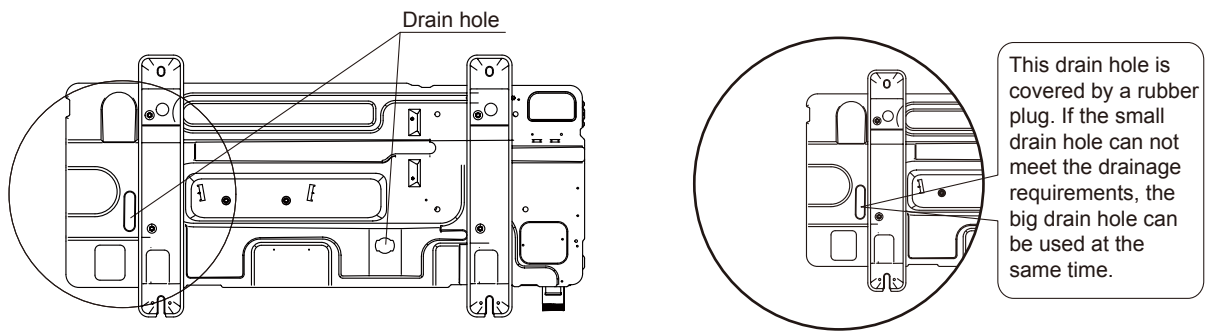

NOTE

It's necessary to install an electrical heating belt if water can't drain out in cold weather even after the big drain hole has been opened.

7.4 Servicing space requirements

7.4.1 In case of stacked installation

1) In case obstacles exist in front of the air outlet side.

2) In case obstacles exist in front of the air inlet side.

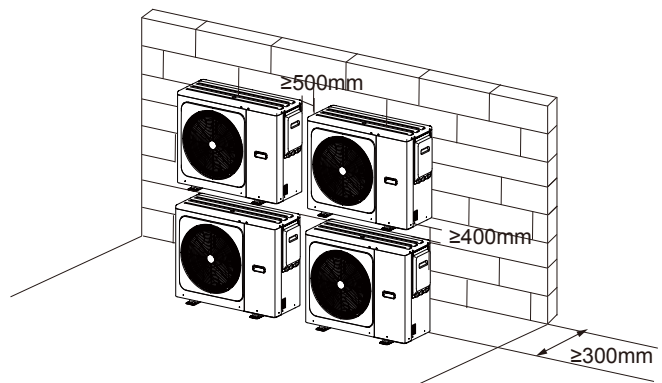
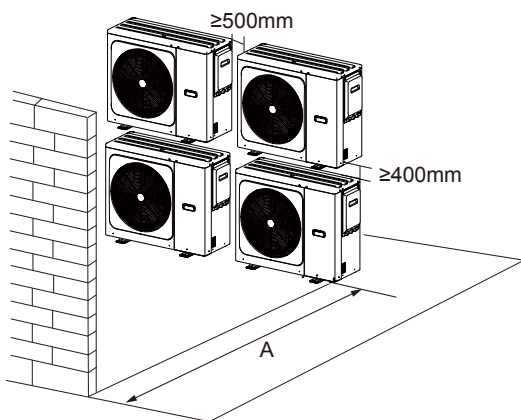

Unit	A(mm)
5~9kW	≥1000
12~16kW	≥1500

7.4.2 In case of multiple-row installation (for roof top use, etc.)

In case of installing multiple units in lateral connection per row.

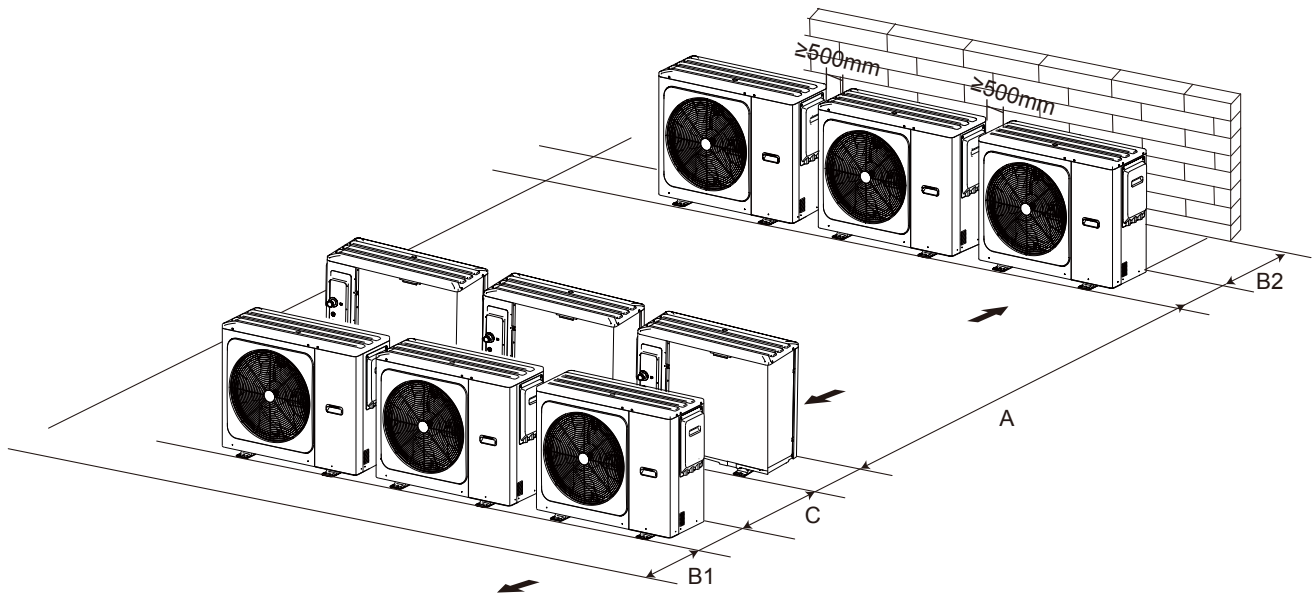

Unit	A(mm)	B1(mm)	B2(mm)	C(mm)
5~9kW	≥ 2500	≥ 1000	≥ 300	≥ 600
12~16kW	≥ 3000	≥ 1500		

8 TYPICAL APPLICATIONS

The application examples given below are for illustration only.

8.1 Application 1

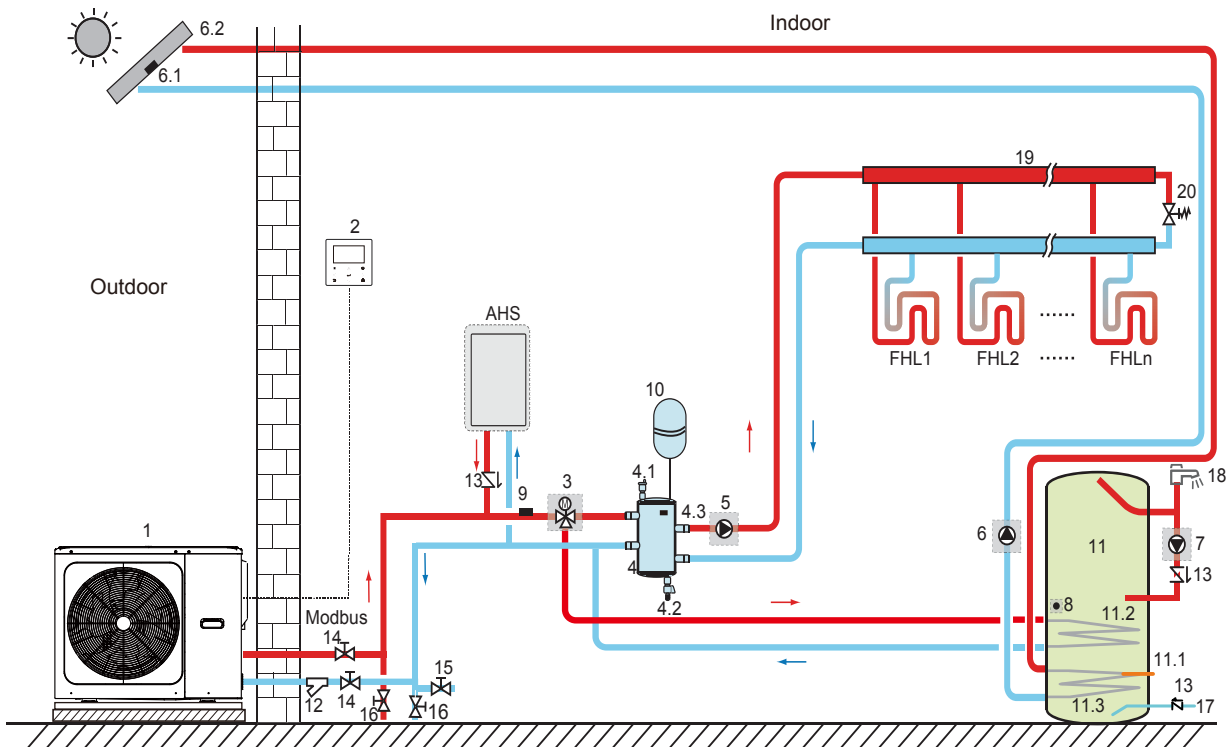

Code	Assembly unit	Code	Assembly unit
1	Main unit	11	Domestic hot water tank (Field supply)
2	User interface	11.1	TBH: Domestic hot water tank booster heater (Field supply)
3	SV1:3-way valve (Field supply)	11.2	Coil 1, heat exchanger for heat pump
4	Buffer tank (Field supply)	11.3	Coil 2, heat exchanger for Solar energy
4.1	Automatic air purge valve	12	Filter (Accessory)
4.2	Drainage valve	13	Check valve (Field supply)
4.3	Tbt: Buffer tank upper temperature sensor (Optional)	14	Shut-off valve (Field supply)
5	P_o: Outside circulation pump(Field supply)	15	Filling valve (Field supply)
6	P_s: Solar pump (Field supply)	16	Drainage valve (Field supply)
6.1	Tsolar: Solar temperature sensor (Optional)	17	Tap water inlet pipe (Field supply)
6.2	Solar panel (Field supply)	18	Hot water tap (Field supply)
7	P_d: DHW pipe pump (Field supply)	19	Collector/distributor (Field supply)
8	T5: Domestic water tank temperature sensor (Accessory)	20	Bypass valve (Field supply)
9	T1:Total water flow temperature sensor (Optional)	FHL 1...n	Floor heating loop (Field supply)
10	Expansion vessel (Field supply)	AHS	Auxiliary heat source (Field supply)

- **Space heating**

The ON/OFF signal and operation mode and temperature setting are set on the user interface. P_o keeps running as long as the unit is ON for space heating, SV1 stays OFF.

- **Domestic water heating**

The ON/OFF signal and target tank water temperature (T5S) are set on the user interface. P_o stops running as long as the unit is ON for domestic water heating, SV1 stays ON.

- **AHS (auxiliary heat source) control**

The AHS function is set on the user interface. (AHS function can be set valid or invalid in "OTHER HEATING SOURCE" or "FOR SERVICEMAN".)

1) When the AHS is set to be valid only for heating mode, AHS can be turned on in the following ways:

a. Turn on the AHS via BACKHEATER function on the user interface;

b. AHS will be turned on automatically if initial water temperature is too low or target water temperature is too high at low ambient temperature.

P_o keeps running as long as the AHS is ON, SV1 stays OFF.

2) When the AHS is set to be valid for heating mode and DHW mode. In heating mode, AHS control is the same as part 1); In DHW mode, AHS will be turned on automatically when the initial domestic water temperature T5 is too low or the target domestic water temperature is too high at low ambient temperature. P_o stops running, SV1 stays ON.

3) When the AHS is set valid, M1M2 can be set to be valid on the user interface. In heating mode, AHS will be turned on if M1M2 dry contact closes. This function is invalid in DHW mode.

- **TBH (tank booster heater) control**

The TBH function is set on the user interface. (TBH function can be set valid or invalid in "OTHER HEATING SOURCE" or "FOR SERVICEMAN".)

1) When the TBH is set to be valid, TBH can be turned on via TANKHEATER function on the user interface; In DHW mode, TBH will be turned on automatically when the initial domestic water temperature T5 is too low or the target domestic water temperature is too high at low ambient temperature.

2) When the TBH is set to be valid, M1M2 can be set to be valid on the user interface. TBH will be turned on if M1M2 dry contact closes.

Solar energy control

- Hydraulic module recognizes solar energy signal by judging Tsolar or receiving SL1SL2 signal from user interface. The recognition method can be set via SOLAR INPUT on the user interface.

1) When Tsolar is set to be valid, Solar energy turns ON when Tsolar is high enough, P_s starts running; Solar energy turns OFF when Tsolar is low, P_s stops running.

2) When SL1SL2 control is set to be valid, Solar energy turns ON after receiving Solar kit signal from user interface, P_s starts running; Without solar kit signal, Solar energy turns OFF, P_s stops running.

CAUTION

The highest outlet water temperature may reach 70°C. Use caution to avoid burns.

NOTE

Make sure to install the (SV1) 3-way valve correctly. For more details, please refer to 9.6.6 "Connection for other components."

At extremely low ambient temperature, the domestic hot water is exclusively heated by TBH, which assures that the heat pump can be used for space heating with full capacity.

Details on domestic hot water tank configuration for low outdoor temperatures (T4DHWMIN) can be found in "DHW MODE SETTING" of "FOR SERVICEMAN".

8.2 Application 2

ROOM THERMOSTAT control for space heating or cooling need to be set on the user interface. It can be set in three ways: MODE SET/ONE ZONE/DOUBLE ZONE. The unit can be connected to a low voltage room thermostat.

8.2.1 One zone control

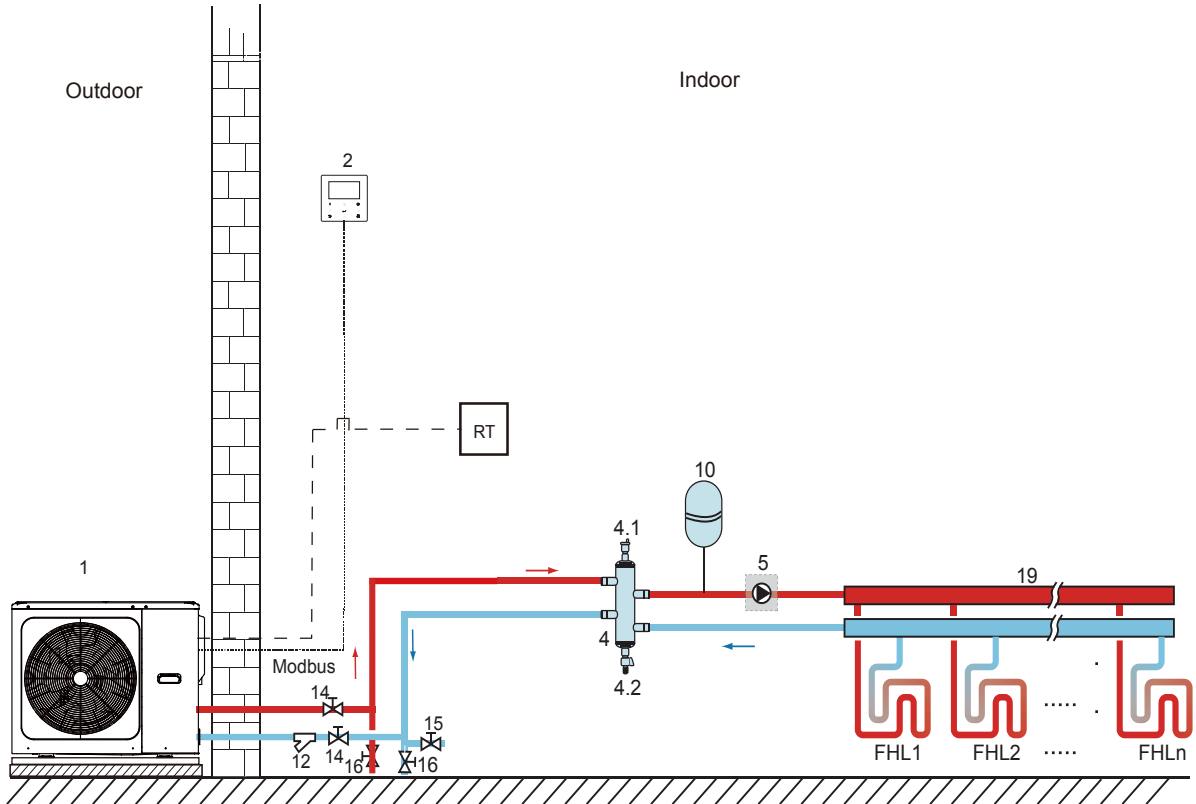

Code	Assembly unit	Code	Assembly unit
1	Main unit	12	Filter (Accessory)
2	User interface	14	Shut-off valve (Field supply)
4	Buffer tank (Field supply)	15	Filling valve (Field supply)
4.1	Automatic air purge valve	16	Drainage valve (Field supply)
4.2	Drainage valve	19	Collector/distributor (Field supply)
5	P_o: Outside circulation pump (Field supply)	RT	Low voltage room thermostat (Field supply)
10	Expansion vessel (Field supply)	FHL 1...n	Floor heating loop (Field supply)

- **Space heating**
One zone control: the unit ON/OFF is controlled by the room thermostat, operation mode and outlet water temperature are set on the user interface. System is ON when "H,L" of the thermostat keep closing for 15s. When "H,L" keep opening for 15s, system turns OFF.
- **The circulation pump operation**
When the system is ON, which means "H,L" of the thermostat close, P_o starts running; When the system is OFF, which means "H,L" open, P_o stops running.

8.2.2 Mode set control

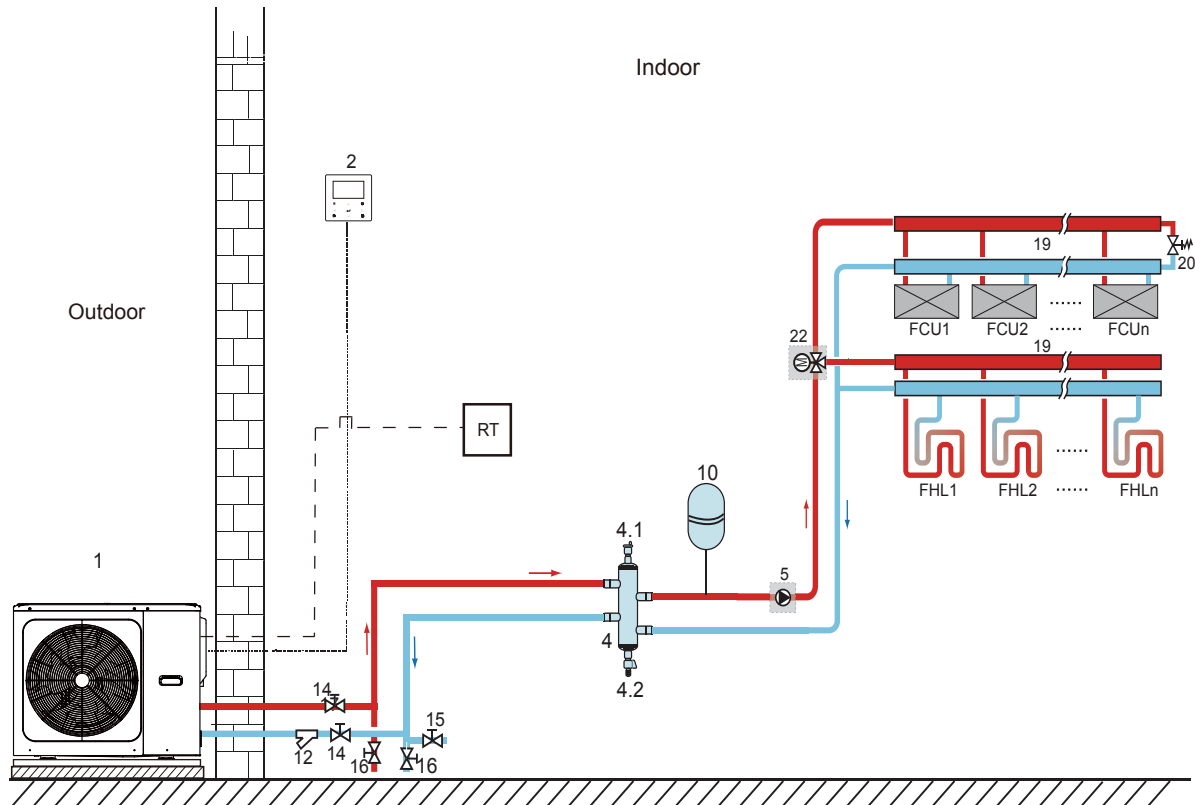

Code	Assembly unit	Code	Assembly unit
1	Main unit	15	Filling valve (Field supply)
2	User interface	16	Drainage valve (Field supply)
4	Buffer tank (Field supply)	19	Collector/distributor
4.1	Automatic air purge valve	20	Bypass valve (Field supply)
4.2	Drainage valve	22	SV2: 3-way valve (Field supply)
5	P_o: Outside circulation pump (Field supply)	RT	Low voltage room thermostat
10	Expansion vessel (Field supply)	FHL1...n	Floor heating loop (Field supply)
12	Filter (Accessory)	FCU1...n	Fan coil unit (Field supply)
14	Shut-off valve (Field supply)		

- Space heating

Operation mode and ON/OFF of the unit are set via the room thermostat, water temperature is set on the user interface.

- 1) When "CL" of the thermostat keep closing for 15s, the system will run according to the priority mode set on the user interface.
- 2) When "CL" of the thermostat keep opening for 15s and "HL" close, the system will run according to the non-priority mode set on the user interface.
- 3) When "HL" of the thermostat keep opening for 15s and "CL" open, the system will turn off.
- 4) When "CL" of the thermostat keep opening for 15s and "HL" open, the system will turn off.

- The circulation pump and valve operation

- 1) When the system is in cooling mode, SV2 keeps OFF, P_o starts running.
- 2) When the system is in heating mode, SV2 keeps ON, P_o starts running.

8.2.3 Double zone control

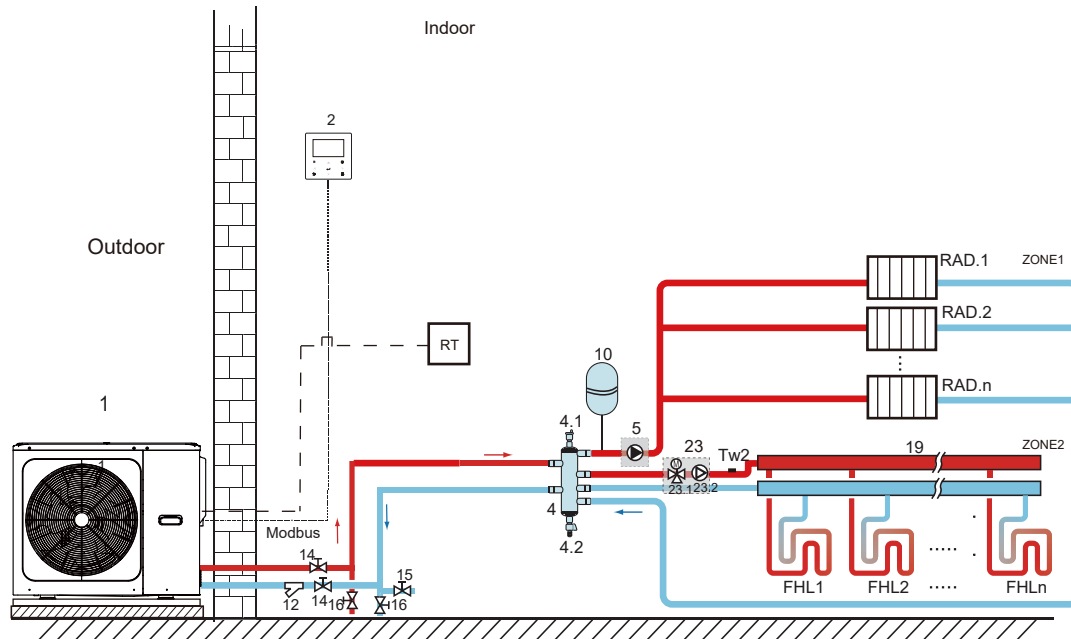

Code	Assembly unit	Code	Assembly unit
1	Main unit	16	Drainage valve (Field supply)
2	User interface	19	Collector/distributor (Field supply)
4	Buffer tank (Field supply)	23	Mixing station (Field supply)
4.1	Automatic air purge valve	23.1	SV3: Mixing valve (Field supply)
4.2	Drainage valve	23.2	P_c: zone 2 circulation pump (Field supply)
5	P_o: zone 1 circulation pump (Field supply)	RT	Low voltage room thermostat (Field supply)
10	Expansion vessel (Field supply)	Tw2	Zone 2 water flow temperature sensor (Optional)
12	Filter (Accessory)	FHL1...n	Floor heating loop (Field supply)
14	Shut-off valve (Field supply)	RAD.1...n	Radiator (Field supply)
15	Filling valve (Field supply)		

• Space heating

Zone1 can operate in cooling mode or heating mode, while zone2 can only operate in heating mode; Operation mode and water temperature are set on the user interface, the unit ON/OFF is controlled by the room thermostat. While installing the system, only "H L" terminals need to be connected for the thermostat in zone1, only "C L" terminals need to be connected for the thermostat in zone2.

- 1) When "HL" keeps closing for 15s, zone1 turns ON. When "HL" keeps opening for 15s, zone1 turns OFF.
- 2) When "CL" keeps closing for 15s, zone2 turns ON. When "CL" keeps opening for 15s, zone2 turns OFF.

• The circulation pump and valve operation

When zone 1 is ON, P_o starts running; When zone 1 is OFF, P_o stops running;

When zone 2 is ON, SV3 switches between ON and OFF according to the set TW2, P_c keeps ON; When zone 2 is OFF, SV3 is OFF, P_c stops running.

The floor heating loops require a lower water temperature in heating mode compared to radiators or fan coil unit. To achieve these two set points, a mixing station is used to adapt the water temperature according to requirements of the floor heating loops. The radiators are directly connected to the unit water circuit and the floor heating loops are after the mixing station. The mixing station is controlled by the unit.

⚠ CAUTION

- 1) Make sure to install the 3-way valve SV2/SV3 correctly. Please refer to 9.6.6 "Connection for other components".
- 2) Make sure the wirings of the room thermostat is correct. Please refer to 9.6.6 "Connection for other components".

NOTE

Drainage valve must be installed at the lowest position of the piping system.

8.3 Cascade system

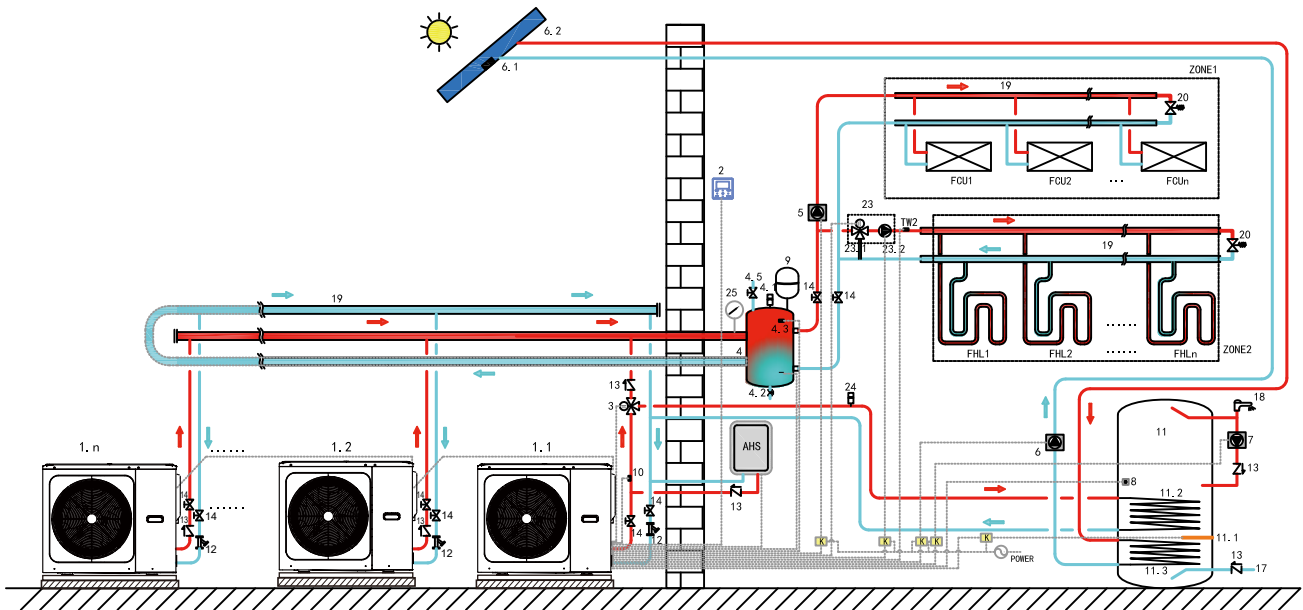

Code	Assembly unit	Code	Assembly unit	Code	Assembly unit
1.1	Master unit	5	P_O:Outside circulation pump (Field supply)	11.1	TBH: Domestic hot water tank booster heater
1.2...n	Subordinate unit	6	P_S: Solar pump (Field supply)	11.2	Coin 1,heat exchanger for heat pump
2	User interface	6.1	Tsolar:Solar temperature sensor (Optional)	11.3	Coin 2,heat exchanger for solar energy
3	SV1:3-way valve (Field supply)	6.2	Solar panel (Field supply)	12	Filter (Accessory)
4	Buffer tank (Field supply)	7	P_D:DHW pipe pump (Field supply)	13	Check valve (Field supply)
4.1	Automatic air purge valve	8	T5:Domestic water tank temperature sensor (Accessory)	14	Shut-off valve (Field supply)
4.2	Drainage valve	9	Expansion vessel (Field supply)	17	Tap water inlet pipe (Field supply)
4.3	Tbt: Buffer tank upper temperature sensor (optional)	10	T1:Total water flow temperature sensor (Optional)	18	Hot water tap (Field supply)
4.5	Filling valve	11	Domestic hot water tank (Field supply)	19	Collector/distributor (Field supply)

20	Bypass valve (Field supply)	25	Water manometer (Field supply)	ZONE1	The space operates in cooling or heating mode
23	Mixing station (Field supply)	TW2	Zone2 water flow temperature sensor (Optional)	ZONE2	The space only operates in heating mode
23.1	SV3:Mixing valve (Field supply)	FCU1...n	Fan coil unit(Field supply)	AHS	Auxiliary heating source(Field supply)
23.2	P_C:Zone2 circulation pump (Field supply)	FHL1...n	Floor heating loop (Field supply)		
24	Automatic air purge valve (Field supply)	K	Contactora (Field supply)		

- **Domestic water heating**

Only master unit (1.1) can operate in DHW mode. T5S is set on the user interface (2). In DHW mode, SV1(3) stays ON. When master units operate in DHW mode, subordinate units can operate in space cooling or heating mode.

- **Subordinate heating**

All subordinate units can operate in space heating mode. The operation mode and setting temperature are set on the user interface (2). Due to changes of the outdoor temperature and the required load indoors, multiple outdoor units may operate at different times.

In cooling mode, SV3(23.1)and P_C (23.2)keep OFF, P_O (5) keeps ON;

In heating mode, when both ZONE 1 and ZONE 2 work, P_C (23.2)and P_O (5) keep ON, SV3 (23.1) switches between ON and OFF according to the set TW2;

In heating mode, when only ZONE 1 works, P_O (5) keep ON, SV3 (23.1) and P_C (23.2) keep OFF.

In heating mode, when only ZONE 2 works, P_O (5) keep OFF, P_C (23.2) keeps ON, SV3 (23.1) switches between ON and OFF according to the set TW2;

- **AHS(Auxiliary heat source) Control**

The AHS function is set on the user interface. (AHS function can be set valid or invalid in "OTHER HEATING SOURCE" of "FOR SERVICEMAN".) ;AHS is only controlled by the master unit. When the master unit operates in DHW mode , AHS can only be used for producing domestic hot water; when the master unit operates in heating mode, AHS can be used for heating mode.

1)When AHS is set valid only in heating mode, it will be turned on in following conditions:

a.Turn on BACKUPHEATER function on user interface;

b.Master unit operates in heating mode. When inlet water temperature is too low, or while ambient temperature is too low, the target leaving water temperature is too high, AHS will be turned on automatically.

2)When AHS is set valid in heating mode and DHW mode, it will be turned on in following conditions:

When master unit operates in heating mode, conditions of turning on AHS is same as 1); When master unit operates in DHW mode, if T5 is too low or when ambient temperature is too low, target T5 temperature is too high, AHS will be turned on automatically.

3)When AHS is valid, and the operation of AHS is controlled by M1M2. When M1M2 closes, AHS is turned on. When master unit operates in DHW mode, AHS can't be turned on by closing M1M2.

- **TBH (Tank booster heater) Control**

The TBH function is set on the user interface. (TBH function can be set valid or invalid in "OTHER HEATING SOURCE" of "FOR SERVICEMAN".) TBH is only controlled by the master unit. Please refer to 8.1 Application 1 for TBH control.

- **Solar energy Control**

Solar energy is only controlled by the master unit. Please refer to 8.1 Application 1 for solar energy control.

NOTE

1. A maximum of 6 units can be cascaded in one system. One unit is the master unit, the others are subordinate units. The master unit and the subordinate units are distinguished by whether they are connected to the wired controller while powering on. The unit with the wired controller is the master unit, units without the wired controller are subordinate units. Only the master unit can operate in DHW mode. During installation, check the cascade system diagram and determine the master unit. Before powering on, remove all wired controllers from subordinate units.

2. SV2, SV3, P_O, T1, TW2, Tbt, AHS interface are only connected to corresponding terminals on the main board of the master unit.

3. The system has an auto-addressing function. After initial powering on, the master unit will assign addresses for the subordinate units. Subordinate units will keep the addresses. After powering on again, subordinate units will still use the previous addresses. The addresses of subordinate units do not need to be set again.

4. If a Hd malfunction occurs, please refer to 14.3 "Error codes."

5. It is suggested to use the reversed return water system to avoid hydraulic imbalance between each unit in a cascade system.

⚠ CAUTION

1. In a cascade system, a Tbt sensor must be connected to the maaster unit and Tbt set to valid on the user interface, otherwise all subordinate units will not work.
- 2.If outside circulation pump need to be connected in series in system when the head of internal water pump is not enough, outside circulation pump is suggested to be installed after the balance tank.
- 3.Please ensure that the maximum interval of power-on time of all units doesn't exceed 2min, otherwise the time for querying and allocating addresses will be missed, which may cause the slaves to fail to communicate normally and report Hd error.
- 4.Maximum 6 units can be cascaded in one system.
- 5.The outlet pipe of each unit must be installed with a check valve.

8.4 Buffer tank volume requirement

NO.	Model	Buffer tank(L)
1	5~9 kW	≥ 25
2	12~16 kW	≥ 40
3	Cascade system	≥ 40*n
n:The outdoor unit numbers		

9 OVERVIEW OF THE UNIT

9.1 Main components

9.1.1 Hydraulic module

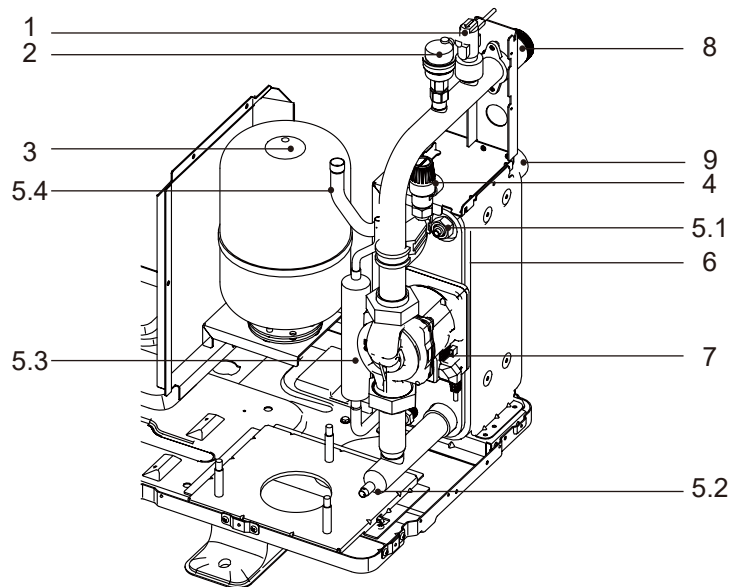

Code	Assembly unit	Explanation
1	Flow switch	Detects water flow rate to protect compressor and water pump in the event of insufficient water flow.
2	Automatic air purge valve	Remaining air in the water circuit will be automatically removed from the water circuit.
3	Expansion vessel	Balances water system pressure.
4	Pressure relief valve	Prevents excessive water pressure by opening at 3 bar and discharging water from the water circuit.
5	Temperature sensor	Four temperature sensors determine the water and refrigerant temperature at various points in the water circuit . 5.1 -TW-out; 5.2 -Tw-in; 5.3 -T2; 5.4 -T2B
6	Plate heat exchanger	Transfer heat from the refrigerant to the water.
7	Pump	Circulates water in the water circuit.
8	Water inlet	/
9	Water outlet	/

9.2 Control board

9.2.1 Hydraulic module board

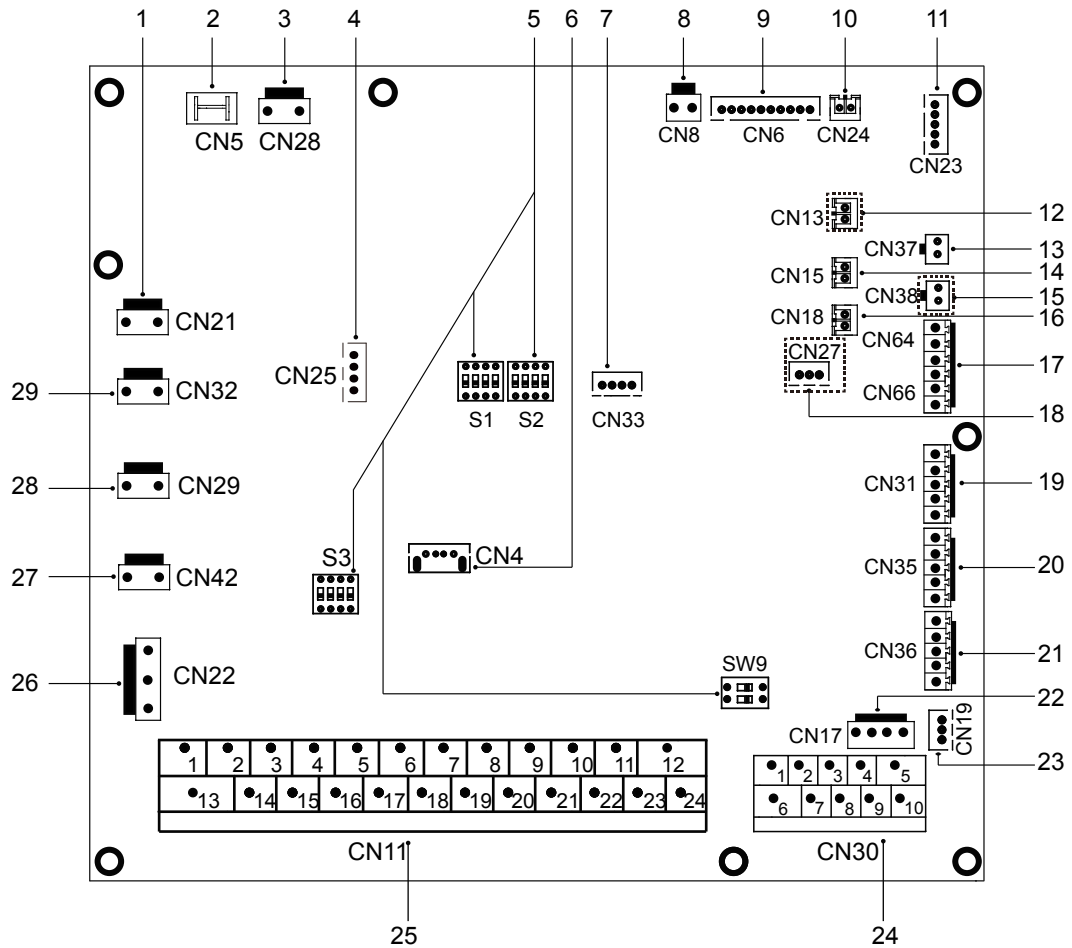

Order	Port	Code	Assembly unit	Order	Port	Code	Assembly unit	
1	CN21	POWER	Port for power supply	18	CN27	HA/HB	Port for communication with the HOME BUS wired controller (Reserved)	
2	CN5	GND	Port for ground	19	CN31	10V GND	Output port for 0-10V	
3	CN28	PUMP	Port for variable speed pump power input			HT	Control port for room thermostat (heating mode)	
4	CN25	DEBUG	Port for IC programming			COM	Power port for room thermostat	
5	S1,S2,S3,SW9	/	Dip switch			CL	Control port for room thermostat (cooling mode)	
6	CN4	USB	Port for USB programming	20	CN35	SG	Port for smart grid (grid signal)	
7	CN33	/	Port for breathing light			EVU	Port for smart grid (photovoltaic signal)	
8	CN8	FS	Port for flow switch	21	CN36	M1 M2	Port for remote switch	
				22	CN17	T1 T2	Port for thermostat transfer board	
				23	CN19	P Q	Port for variable speed pump communication	
						3 4	Communicate port between indoor unit and outdoor unit	
9	CN6	T2	Port for refrigerant liquid side temperature (heating mode)	24	CN30	6 7	Communicate port between hydraulic module board and main control board	
		T2B	Port for temperature sensors of refrigerant gas side temperature (cooling mode)			9 10	Port for Internal machine Cascade	
		TW_in	Port for temperature sensors of inlet water temperature of plate heat exchanger			1 2	Port for additional heat source	
		TW_out	Port for temperature sensors of outlet water temperature of plate heat exchanger			3 4 17	Port for SV1(3-way valve)	
		T1	Port for temperature sensors of final outlet water temperature			5 6 18	Port for SV2(3-way valve)	
10	CN24	Tbt	Port for temperature sensor of balance tank			7 8 19	Port for SV3(3-way valve)	
11	CN23	RH	Port for humidity sensor	25	CN11	9 20	Port for zone 2 pump	
12	CN13	T5	Port for domestic hot water tank temp. sensor (Reserved)			10 21	Port for outside circulation pump	
13	CN37	Pw	Port for temperature sensor of water pressure			11 22	Port for solar energy pump	
14	CN15	Tw2	Port for outlet water for zone 2 temp. sensor			12 23	Port for DHW pipe pump	
15	CN38	T52	Port for temperature sensor of balance tank 2 (Reserved)			13 16	Control port for tank booster heater	
16	CN18	Tsolar	Port for solar panel temp sensor			14 16	Control port for internal backup heater 1	
17	CN66	K1 K2	Input port (Reserved)			15 17	Control port for internal backup heater 2	
		S1 S2	Input port for solar energy	26		CN22	24 23	Output port for alarm/Defrost run
							IBH1	Control port for internal backup heater 1
							IBH2	Control port for internal backup heater 2
						TBH	Control port for tank booster heater	
				27		CN42	HEAT6	Port for anti-freeze electric heating tape(internal)
				28	CN29	HEAT5	Port for anti-freeze electric heating tape(internal)	
				29	CN32	AC OUT	Port for backup heater	

9.2.2 Main control board

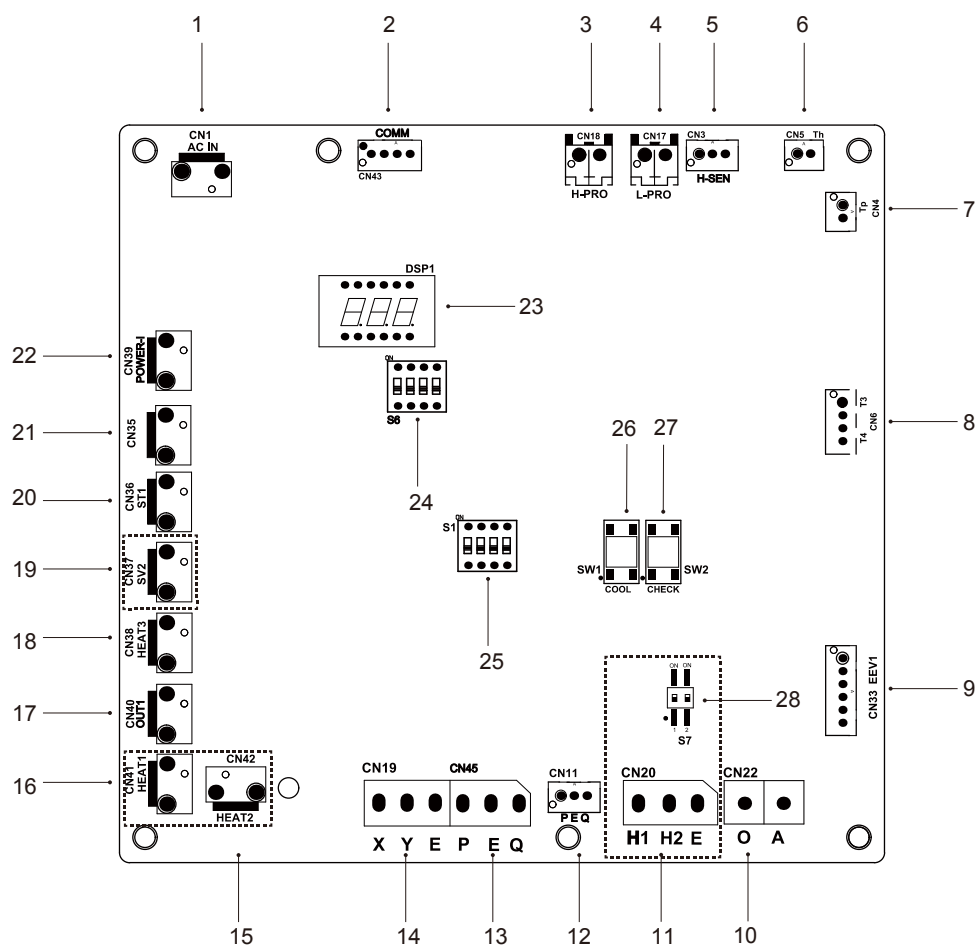

Code	Assembly unit	Code	Assembly unit
1	Power input port from Main control board (CN1)	15	Reserved(CN42)
2	Port for communication with Inverter module (CN43)	16	Reserved(CN41)
3	Port for high pressure switch (CN18)	17	OUT1 (CN40)
4	Port for low pressure switch (CN17)	18	Port for crankcase heating tape(CN38)
5	Port for high pressure sensor(CN3)	19	SV2 (CN37) (Reserved)
6	Port for TH temp.sensor(CN5)	20	Port for 4-way valve(CN36)
7	Port for TP temp.sensor(CN4)	21	Port for the heating tape of drainage outlet(CN35)
8	Port for T3,T4 temp.sensor(CN6)	22	Power output port to hydraulic module board (CN39)
9	Port for electrical expansion valve1(CN33)	23	Digital display(DSP1)
10	Port for communication with ammeter(CN22)	24	Dip switch S6
11	Port for communication with outdoor unit (CN20) (Reserved)	25	Dip switch S1
12	Port for communication with hydro-box control board (CN11)	26	Port for Forced cooling(SW1)
13	Same as ITEM 12(CN45 PQE)	27	Port for point check(SW2)
14	Port for communication with indoor monitor (CN19 XYE)	28	Dip switch S7(Reserved)

9.2.3 1-phase for 5-16kW units

1) 5/7/9kW, Inverter module

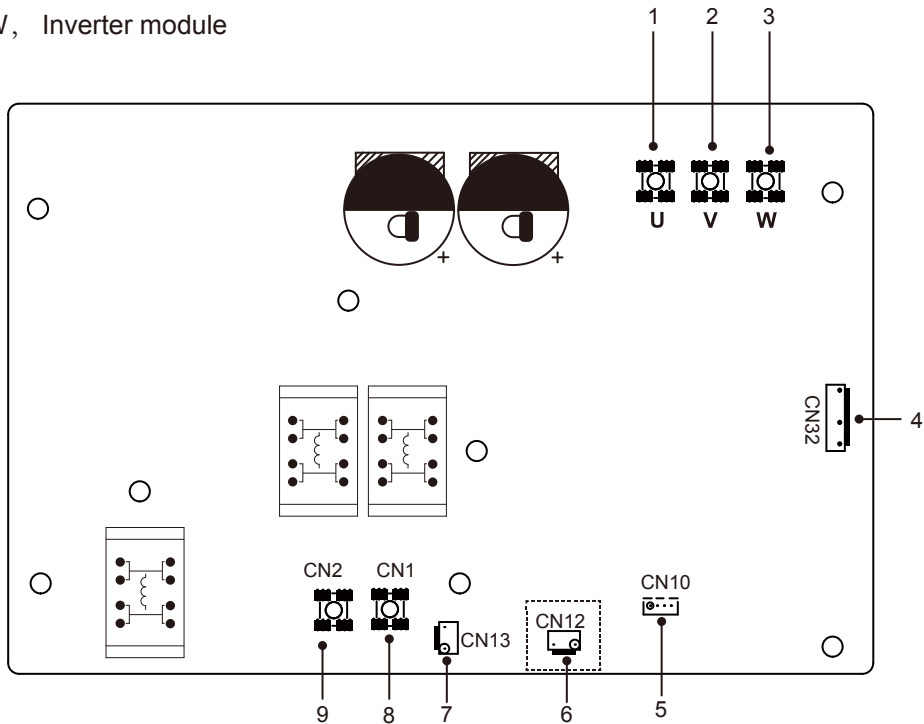

Code	Assembly unit	Code	Assembly unit
1	Compressor connection port U	6	Port for high pressure switch (CN12) (Reserved)
2	Compressor connection port V	7	Port for power supply (CN13)
3	Compressor connection port W	8	Input port L for rectifier bridge (CN501)
4	Port for fan (CN32)	9	Input port N for rectifier bridge (CN502)
5	Port for communication with main control board (CN10)		

2) 12/14/16kW, Inverter module

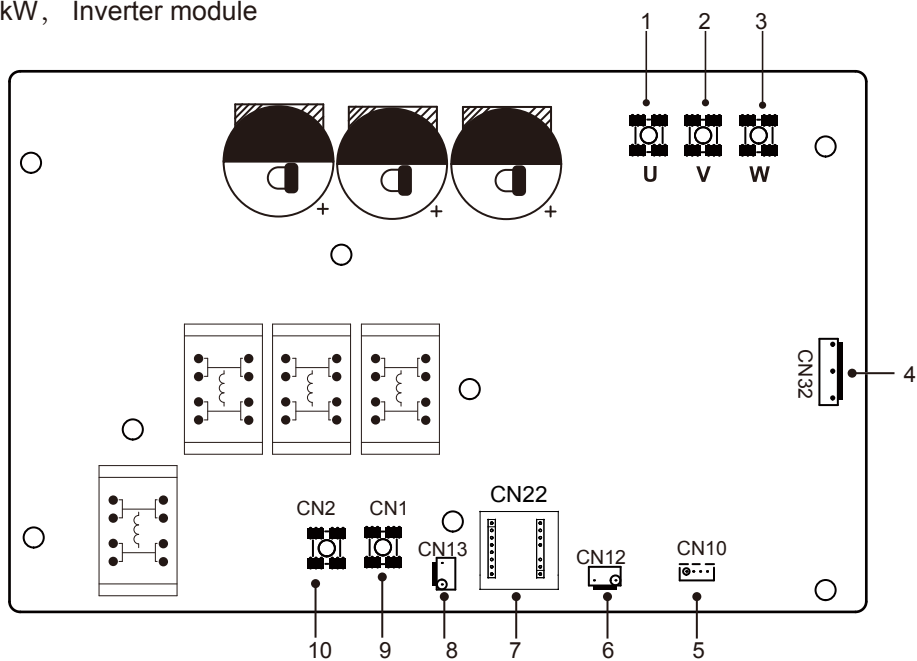

Code	Assembly unit	Code	Assembly unit
1	Compressor connection port U	6	Port for high pressure switch (CN12)
2	Compressor connection port V	7	PED board (CN22)
3	Compressor connection port W	8	Port for power supply (CN13)
4	Port for fan (CN32)	9	Input port L for rectifier bridge (CN501)
5	Port for communication with main control board (CN10)	10	Input port N for rectifier bridge (CN502)

9.2.4 3-phase for 12/14/16 kW units

1) Inverter module

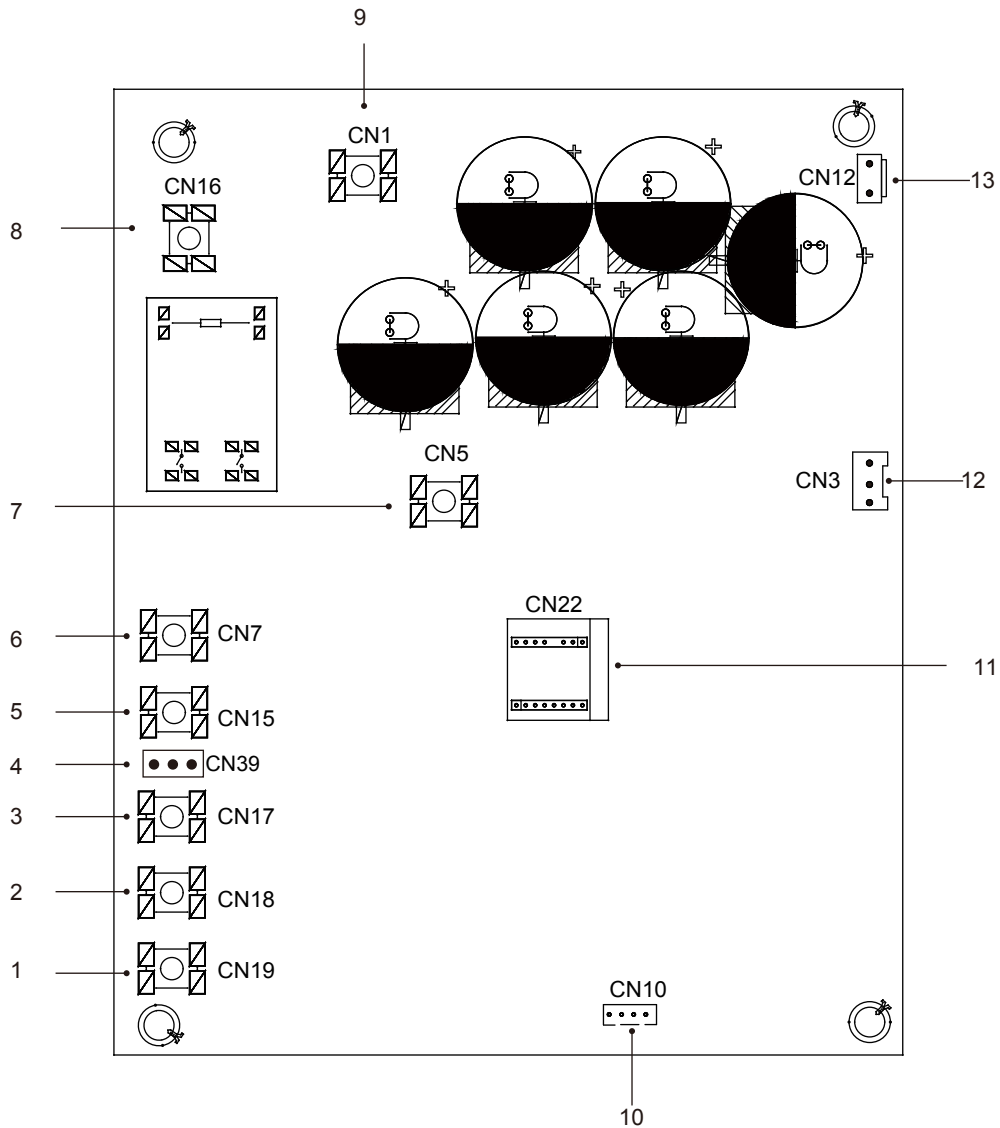

Code	Assembly unit	Code	Assembly unit
1	Compressor connection port W(CN19)	8	Power Input port L1(CN16)
2	Compressor connection port V(CN18)	9	Input port P_in for IPM module(CN1)
3	Compressor connection port U(CN17)	10	Port for communication with main control board (CN43)
4	Port for voltage detection (CN39)	11	PED board(CN22)
5	Power Input port L3(CN15)	12	Port for communication with DC FAN (CN3)
6	Power Input port L2(CN7)	13	Port for high pressure switch (CN12)
7	Input port P_out for IPM module(CN5)		

2) Filter board

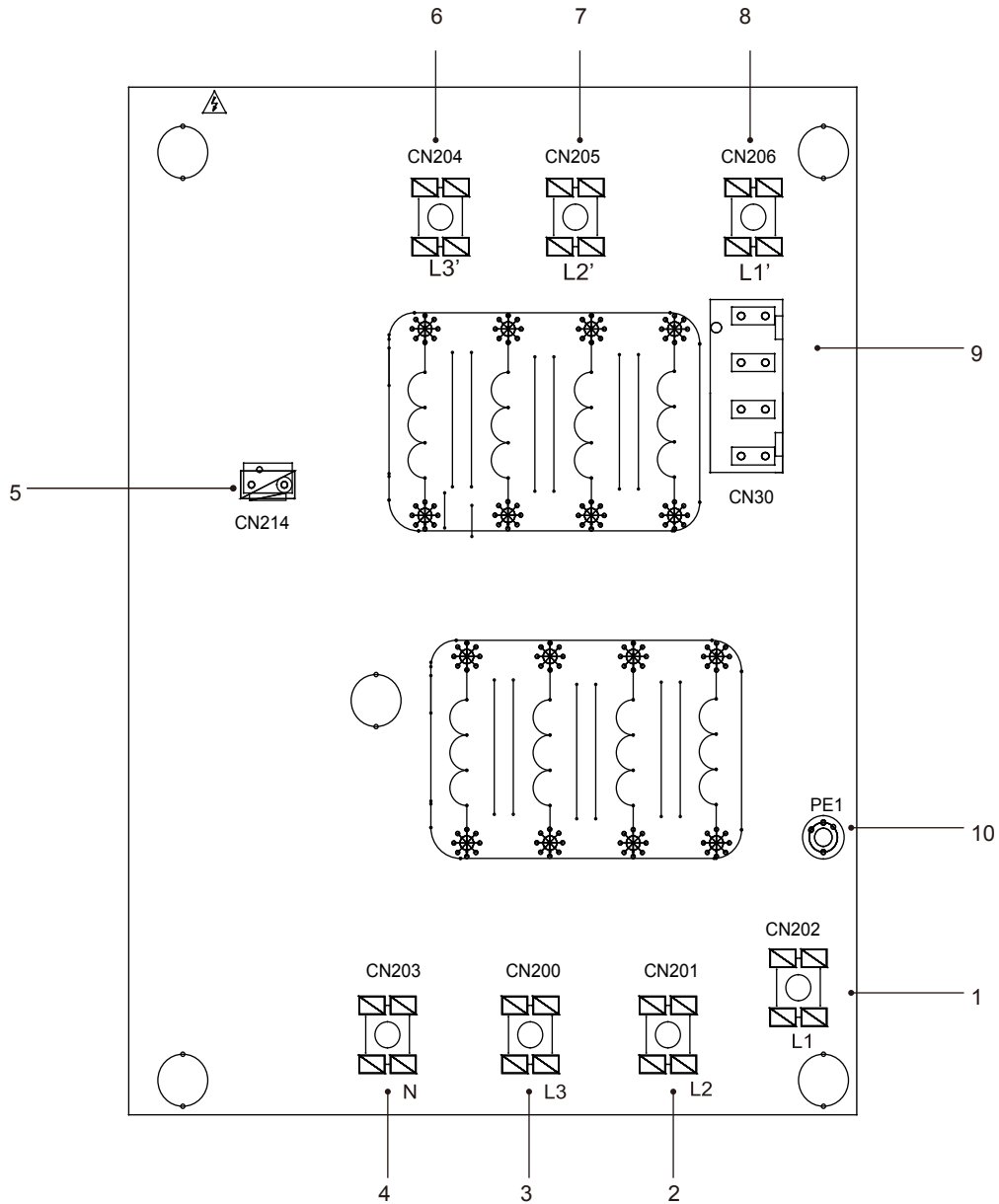

PCB C 3-phase 12/14/16kW

Code	Assembly unit	Code	Assembly unit
1	Power supply L1(CN202)	6	Power filtering output L3'(CN204)
2	Power supply L2(CN201)	7	Power filtering L2'(CN205)
3	Power supply L3(CN200)	8	Power filtering L1'(CN206)
4	Power supply N(CN203)	9	Port for voltage detection(CN30)
5	Power supply port for main control board(CN214)	10	Port for ground wire(PE1)

9.3 Water piping

All piping lengths and distances have been taken into consideration.

Requirements

The maximum allowed thermistor cable length is 20m. This is the maximum allowable distance between the domestic hot water tank and the unit (only for installations with a domestic hot water tank). The thermistor cable supplied with the domestic hot water tank is 10m in length. In order to optimize efficiency we recommend installing the 3-way valve and the domestic hot water tank as close as possible to the unit.

NOTE

If the installation is equipped with a domestic hot water tank (field supply), please refer to the domestic hot water tank Installation And Owner's Manual. If there is no glycol (anti-freeze) in the system or there is a power supply failure or pump failure, drain the system (as shown in the figure below).

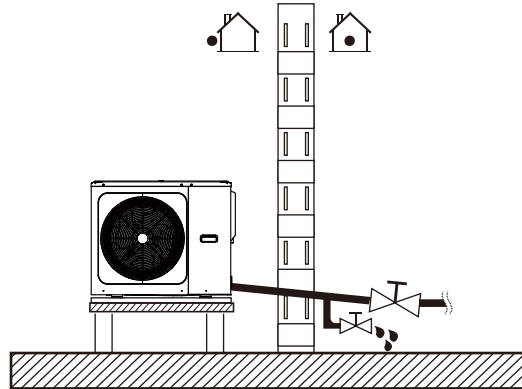

NOTE

If water is not removed from the system in freezing weather when unit is not used, the frozen water may damage the water circle parts.

9.3.1 Check the water circuit

The unit is equipped with a water inlet and water outlet for connection to a water circuit. This circuit must be provided by a licensed technician and must comply with local laws and regulations.

The unit is only to be used in a closed water system. Application in an open water circuit can lead to excessive corrosion of the water piping.

Example:

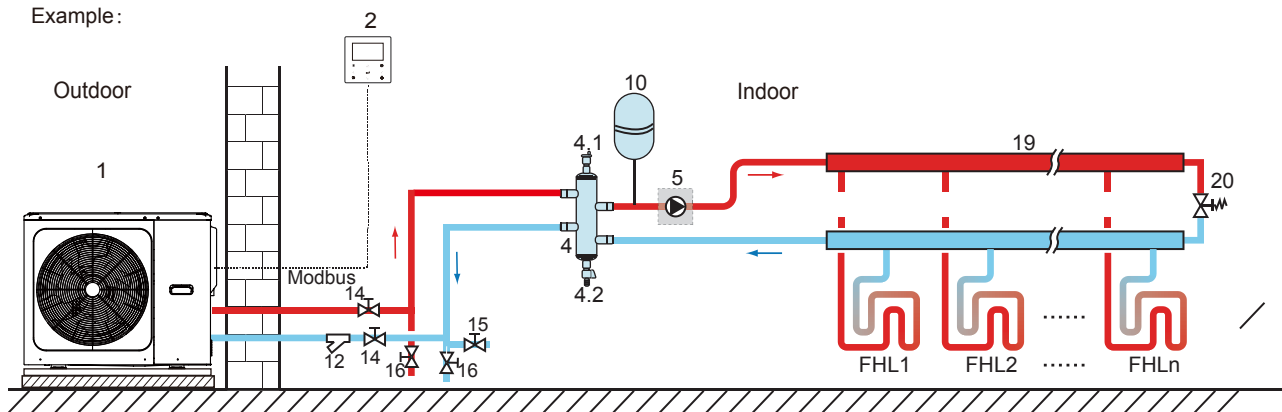

Code	Assembly unit	Code	Assembly unit
1	Main unit	12	Filter (Accessory)
2	User interface(accessory)	14	Shut-off valve (Field supply)
4	Buffer tank (Field supply)	15	Filling valve (Field supply)
4.1	Automatic air purge valve	16	Drainage valve (Field supply)
4.2	Drainage valve	19	Collector/distributor (Field supply)
5	P_o: Outside circulation pump(Field supply)	20	Bypass valve (field supply)
10	Expansion vessel(field supply)	FHL	Floor heating loop (Field supply)
		1...n	

Before continuing installation of the unit, check the following:

- The maximum water pressure ≤ 3 bar.
- The maximum water temperature $\leq 70^{\circ}\text{C}$ according to safety device setting.
- Always use materials that are compatible with the water used in the system and with the materials used in the unit.
- Ensure that components installed in the field piping can withstand the water pressure and temperature.
- Drain taps must be provided at all low points of the system to permit complete drainage of the circuit during maintenance.
- Air vents must be provided at all high points of the system. The vents should be located at points that are easily accessible for service. An automatic air purge valve is provided inside the unit. Check that this air purge valve is not tightened so that automatic release of air in the water circuit is possible.

9.3.2 Water volume and sizing expansion vessels

The units are equipped with an expansion vessel of 5L that has a default pre-pressure of 1.5 bar. To assure proper operation of the unit, the pre-pressure of the expansion vessel might need to be adjusted.

1) Check that the total water volume in the installation, excluding the internal water volume of the unit, is at least 40L.

NOTE

- In most applications this minimum water volume will be satisfactory.
- In critical processes or in rooms with a high heat load extra water might be required.
- When circulation in each space heating loop is controlled by remotely controlled valves, it is important that this minimum water volume is kept even if all the valves are closed.

2) Expansion vessel volume must fit the total water system volume.

3) To size the expansion for the heating and cooling circuit.

The expansion vessel volume can follow the figure below:

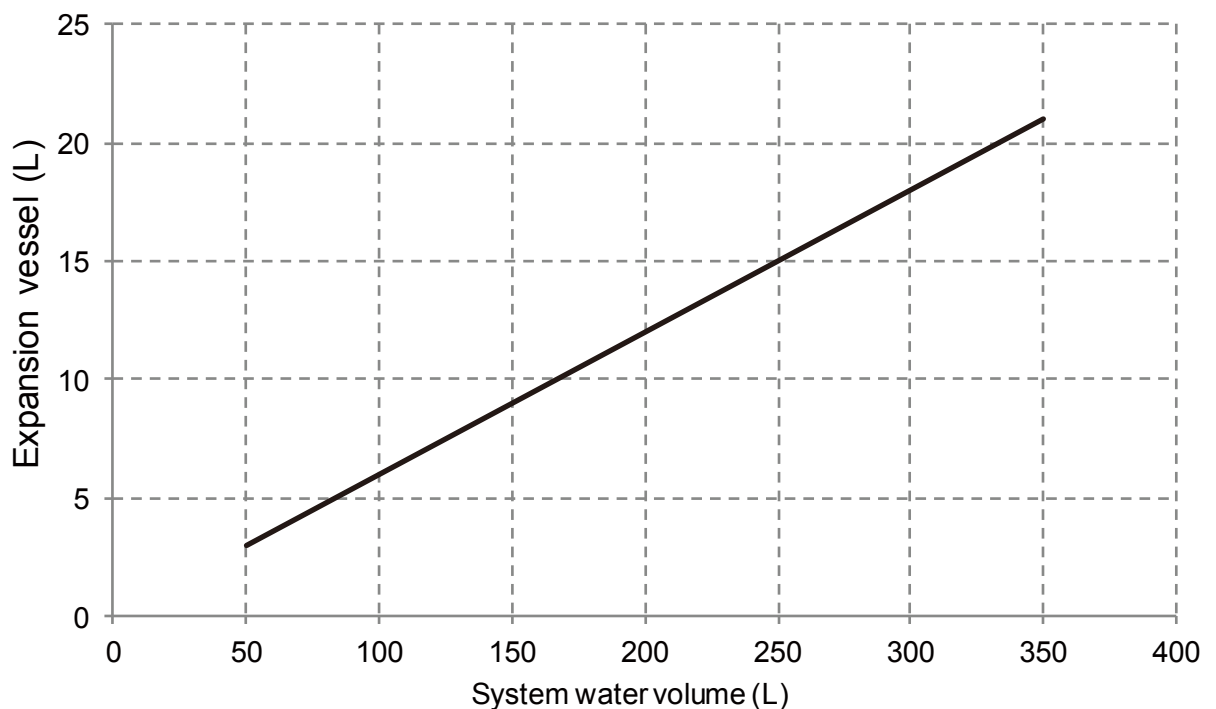

9.3.3 Water circuit connection

Water connections must be made correctly in accordance with labels on the outdoor unit, with respect to the water inlet and water outlet.

⚠ CAUTION

Be careful not to deform the unit's piping by using excessive force when connecting the piping. Deforming the piping can cause the unit to malfunction.

If air, moisture or dust gets in the water circuit, problems may occur. Therefore, always take into account the following when connecting the water circuit:

- Use clean pipes only.
- Hold the pipe end downwards when removing burrs.
- Cover the pipe end when inserting it through a wall to prevent dust and dirt entering.
- Use a good thread sealant for sealing the connections. The sealing must be able to withstand the pressures and temperatures of the system.
- When using non-copper metallic piping, be sure to insulate two kind of materials from each other to prevent galvanic corrosion.
- Copper is a soft material. Use appropriate tools for connecting the water circuit. Inappropriate tools will cause damage to the pipes.

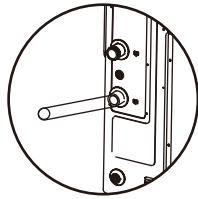

💡 NOTE

The unit is only to be used in a closed water system. Application in an open water circuit can lead to excessive corrosion of the water piping:

- Never use Zn-coated parts in the water circuit. Excessive corrosion of these parts may occur as copper piping is used in the unit's internal water circuit.
- When using a 3-way valve in the water circuit. Preferably choose a ball type 3-way valve to guarantee full separation between the domestic hot water and floor heating water circuit.
- When using a 3-way valve or a 2-way valve in the water circuit. The recommended maximum changeover time of the valve should be less than 60 seconds.

9.3.4 Water circuit anti-freeze protection

All internal hydronic parts are insulated to reduce heat loss. Insulation must also be added to the field piping.

In event of a power failure, the above features would not protect the unit from freezing.

The software contains special functions using the heat pump and backup heater (if optional and available) to protect the entire system against freezing. When the temperature of the water flow in the system drops to a certain value, the unit will heat the water, either using the heat pump, the electric heating tap, or the backup heater. The anti-freeze function will turn off only when the temperature increases to a certain value.

Water may enter into the flow switch and cannot be drained out and may freeze when the temperature is low enough. The flow switch should be removed and dried, then installed in the unit.

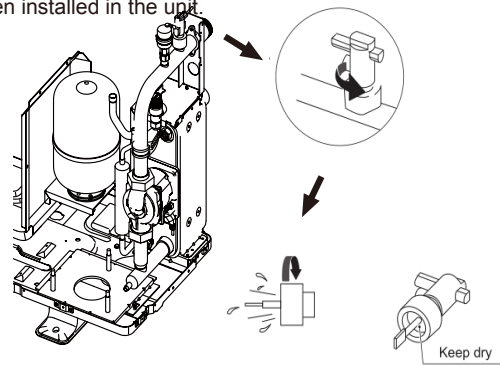

💡 NOTE

- Rotate the flow switch counterclockwise to remove it.
- Dry the flow switch completely.

⚠ CAUTION

When the unit has been out of service for an extended period of time, make sure it is continuously powered. If you want to cut off the power, the water in the system needs to be drained to avoid freezing damage to the unit and the piping system. Unit power needs to be cut off after water in the system is drained.

⚠ WARNING

Ethylene Glycol and Propylene Glycol are toxic.

9.4 Filling water

- Connect the water supply to the filling valve and open the valve.
- Make sure the automatic air purge valve is open.
- Fill until the water pressure is approximately 2.0 bar. Remove air in the circuit as much as possible using the air purge valves. Air in the water circuit could lead to malfunction of the backup electric heater.

Do not fasten the black plastic cover on the vent valve at the top side of the unit when the system is running. Open air purge valve, turn anticlockwise at least 2 full turns to release air from the system.

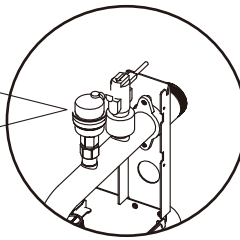

💡 NOTE

During filling, it might not be possible to remove all air from the system. Remaining air will be removed through the automatic air purge valves during the first operating hours of the system. Topping up the water afterwards might be required.

- The water pressure will vary depending on the water temperature (higher pressure at higher water temperature). However, at all times water pressure should remain above 0.3 bar to avoid air entering the circuit.
- The unit might drain-off too much water through the pressure relief valve.
- Water quality should be complied with EN 98/83 EC Directives.
- Detailed water quality condition can be found in EN 98/83 EC Directives.

9.5 Water piping insulation

The complete water circuit including all piping and water piping must be insulated to prevent condensation during cooling operation and reduction of the heating and cooling capacity as well as prevention of freezing of the outside water piping during winter. The insulation material should at least of B1 fire resistance rating and in compliance with all applicable legislation. The thickness of the sealing materials must be at least 13 mm with thermal conductivity 0.039 W/mK in order to prevent freezing on the outside water piping.

If the outdoor ambient temperature is higher than 30°C and the humidity is higher than RH 80%, then the thickness of the sealing materials should be at least 20 mm in order to avoid condensation on the surface of the seal.

9.6 Field wiring

WARNING

A main switch or other means of disconnection, having a contact separation in all poles, must be incorporated in the fixed wiring in accordance with relevant local laws and regulations. Switch off the power supply before making any connections. Use only copper wires. Never squeeze bundled cables and make sure they do not come in contact with the piping and sharp edges. Make sure no external pressure is applied to the terminal connections. All field wiring and components must be installed by a licensed electrician and must comply with relevant local laws and regulations.

The field wiring must be carried out in accordance with the wiring diagram supplied with the unit and the instructions given below.

Be sure to use a dedicated power supply. Never use a power supply shared by another appliance.

Be sure to establish a ground. Do not ground the unit to a utility pipe, surge protector, or telephone ground. Incomplete grounding may cause electrical shock.

Be sure to install a ground fault circuit interrupter (30 mA). Failure to do so may cause electrical shock.

Be sure to install the required fuses or circuit breakers.

9.6.1 Precautions on electrical wiring work

- Fix cables so that cables do not make contact with the pipes (especially on the high pressure side).
- Secure the electrical wiring with cable ties as shown in the following figure so that it does not come in contact with the piping, particularly on the high-pressure side.
- Make sure no external pressure is applied to the terminal connectors.
- When installing the ground fault circuit interrupter make sure that it is compatible with the inverter (resistant to high frequency electrical noise) to avoid unnecessary opening of the ground fault circuit interrupter.

NOTE

The ground fault circuit interrupter must be a high-speed type breaker of 30 mA (<0.1 s).

- This unit is equipped with an inverter. Installing a phase advancing capacitor not only will reduce the power factor improvement effect, but also may cause abnormal heating of the capacitor due to high-frequency waves. Never install a phase advancing capacitor as it could lead to an accident.

9.6.2 Wiring overview

The illustration below gives an overview of the required field wiring between several parts of the installation.

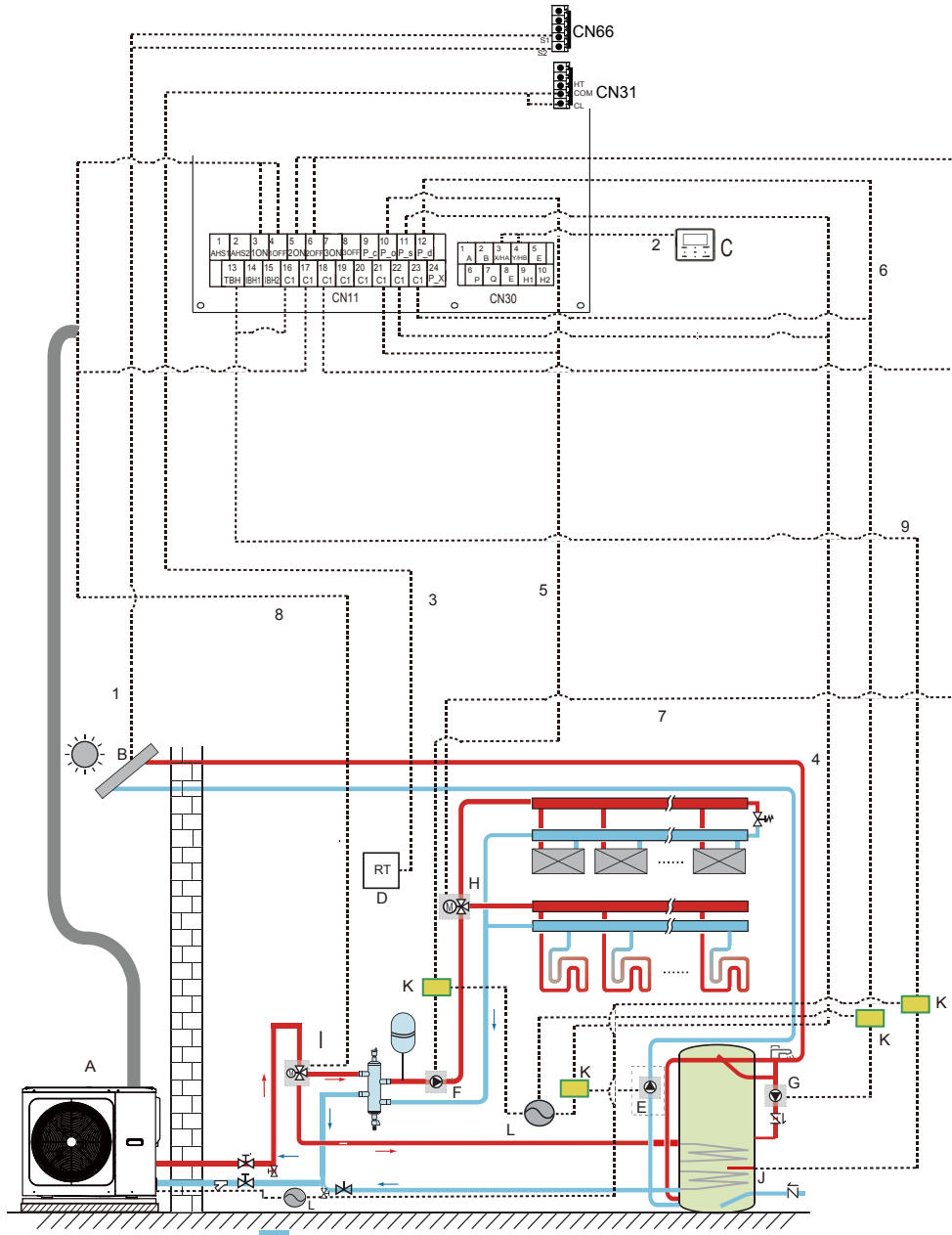

Code	Assembly unit	Code	Assembly unit
A	Main unit	G	P_d:DHW pump(field supply)
B	Solar energy kit(field supply)	H	SV2:3-way valve(field supply)
C	User interface	I	SV1:3-way valve for domestic hot water tank(field supply)
D	Low voltage room thermostat(field supply)	J	Booster heater
E	P_s:Solar pump(field supply)	K	Contactor
F	P_o:Outside circulation pump(field supply)	L	Power supply

Item	Description	AC/DC	Required number of conductors	Maximum running current
1	Solar energy kit signal cable	AC	2	200mA
2	User interface cable	AC	5	200mA
3	Room thermostat cable	AC	2	200mA(a)
4	Solar pump control cable	AC	2	200mA(a)
5	Outside circulation pump control cable	AC	2	200mA(a)
6	DHW pump control cable	AC	2	200mA(a)
7	SV2: 3-way valve control cable	AC	3	200mA(a)
8	SV1: 3-way valve control cable	AC	3	200mA(a)
9	Booster heater control cable	AC	2	200mA(a)

(a) Minimum cable section AWG18 (0.75 mm²).

(b)The thermistor cable are delivered with the unit: if the current of the load is large, an AC contactor is needed.

NOTE

Please use H07RN-F for the power wire, all cables connect to high voltage except for thermistor cable and cable for user interface.

- Equipment must be grounded.
- All high-voltage external load, if it is metal or a grounded port, must be grounded.
- All external load current is needed less than 0.2A, if the single load current is greater than 0.2A, the load must be controlled through AC contactor.
- AHS1" "AHS2" wiring terminal ports only provide the switch signal.
- Expansion valve E-Heating tape, Plate heat exchanger E-Heating tape and Flow switch E-Heating tape share a control port.

Field wiring guidelines

- Most field wiring on the unit is to be done on the terminal block inside the switch box. To gain access to the terminal block, remove the switch box service panel (door 2).

WARNING

Switch off all power including the unit power supply and backup heater and domestic hot water tank power supply (if applicable) before removing the switch box service panel.

- Fix all cables using cable ties.
- A dedicated power circuit is required for the backup heater.
- Installations equipped with a domestic hot water tank (field supply) require a dedicated power circuit for the booster heater. Please refer to the domestic hot water tank Installation & Owner's Manual. Secure the wiring in the order shown below.
- Lay out the electrical wiring so that the front cover does not rise up when doing wiring work and attach the front cover securely.
- Follow the electric wiring diagram for electrical wiring works (the electric wiring diagrams are located on the rear side of door 2).
- Install the wires and fix the cover firmly so that the cover may be fit in properly.

9.6.3 Precautions on wiring of power supply

- Use a round crimp-style terminal for connection to the power supply terminal board. In case it cannot be used due to unavoidable reasons, be sure to observe the following instructions.
- Do not connect different gauge wires to the same power supply terminal. (Loose connections may cause overheating.)
- When connecting wires of the same gauge, connect them according to the figure below.

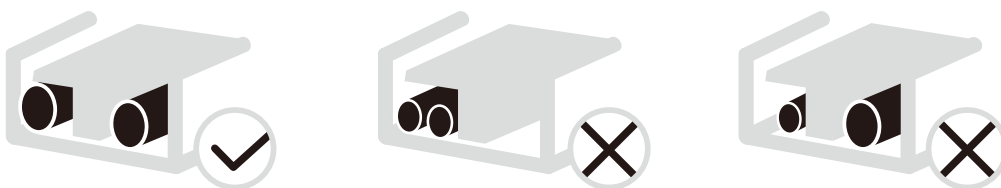

- Use the correct screwdriver to tighten the terminal screws. Small screwdrivers can damage the screw head and prevent appropriate tightening.
- Over-tightening the terminal screws can damage the screws.
- Attach a ground fault circuit interrupter and fuse to the power supply line.
- In wiring, make certain that prescribed wires are used, carry out complete connections, and fix the wires so that outside force cannot affect the terminals.

9.6.4 Safety device requirement

1. Select the wire diameters (minimum value) individually for each unit based on the table 9-1 and table 9-2, where the rated current in table 9-1 means MCA in table 9-2. In case the MCA exceeds 63A, the wire diameters should be selected according to the national wiring regulation.
2. Maximum allowable voltage range variation between phases is 2%.
3. Select a circuit breaker that has a contact separation in all poles not less than 3 mm providing full disconnection, where MFA is used to select the current circuit breakers and residual current operation breakers.

Table 9-1

Rated current of appliance: (A)	Nominal cross-sectional area (mm ²)	
	Flexible cords	Cable for fixed wiring
≤3	0.5 and 0.75	1 and 2.5
>3 and ≤6	0.75 and 1	1 and 2.5
>6 and ≤10	1 and 1.5	1 and 2.5
>10 and ≤16	1.5 and 2.5	1.5 and 4
>16 and ≤25	2.5 and 4	2.5 and 6
>25 and ≤32	4 and 6	4 and 10
>32 and ≤50	6 and 10	6 and 16
>50 and ≤63	10 and 16	10 and 25

Table 9-2 1-phase 5-16kW standard and 3-phase 12-16kW standard

System	Outdoor Unit				Power Current			Compressor		ORM	
	Voltage (V)	Hz	Min. (V)	Max. (V)	MCA (A)	TOCA (A)	MFA (A)	MSC (A)	RLA (A)	KW	FLA (A)
5kW	220-240	50	198	264	13	18	25	-	10.50	0.17	1.50
7kW	220-240	50	198	264	14.5	18	25	-	10.50	0.17	1.50
9kW	220-240	50	198	264	16	18	25	-	10.50	0.17	1.50
12kW 1-PH	220-240	50	198	264	25	30	40	-	17.00	0.17	1.50
14kW 1-PH	220-240	50	198	264	26.5	30	40	-	17.00	0.17	1.50
16kW 1-PH	220-240	50	198	264	28	30	40	-	17.00	0.17	1.50
12kW 3-PH	380-415	50	342	456	9.5	14	16	-	16.00	0.17	0.70
14kW 3-PH	380-415	50	342	456	10.5	14	16	-	16.00	0.17	0.70
16kW 3-PH	380-415	50	342	456	11.5	14	16	-	16.00	0.17	0.70

NOTE

MCA : Minimum. Circuit Amps. (A)

TOCA : Total Over-current Amps. (A)

MFA : Max. Fuse Amps. (A)

MSC : Max. Starting Amps. (A)

RLA : In nominal cooling or heating test conditions, the input Amps of compressor where MAX. Hz can operate Rated Load Amps. (A)

KW : Rated Motor Output

FLA : Full Load Amps. (A)

9.6.5 Remove the switch box cover

1-phase 5-16kW standard and 3-phase 12-16kW standard

Unit	5kW	7kW	9kW	12kW	14kW	16kW	12kW 3-PH	14kW 3-PH	16kW 3-PH
Maximum overcurrent protector(MOP) (A)	18	18	18	30	30	30	14	14	14
Wiring size(mm ²)	4.0	4.0	4.0	6.0	6.0	6.0	2.5	2.5	2.5

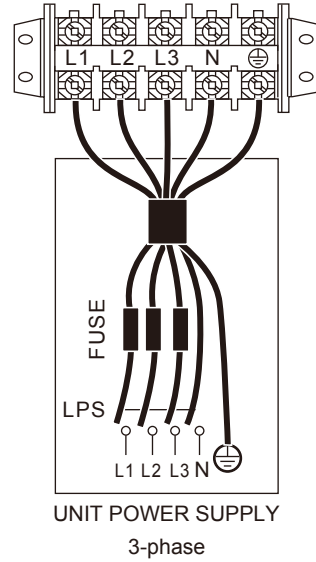
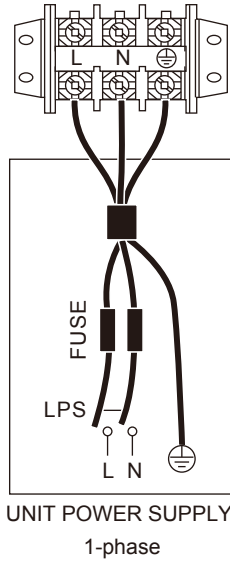

NOTE

The ground fault circuit interrupter must be 1 high-speed type of 30mA (<0.1s). Please use 3-core shielded wire.

Stated values are maximum values (see electrical data for exact values).

Leakage protection switch must be installed to the power supply of the unit.

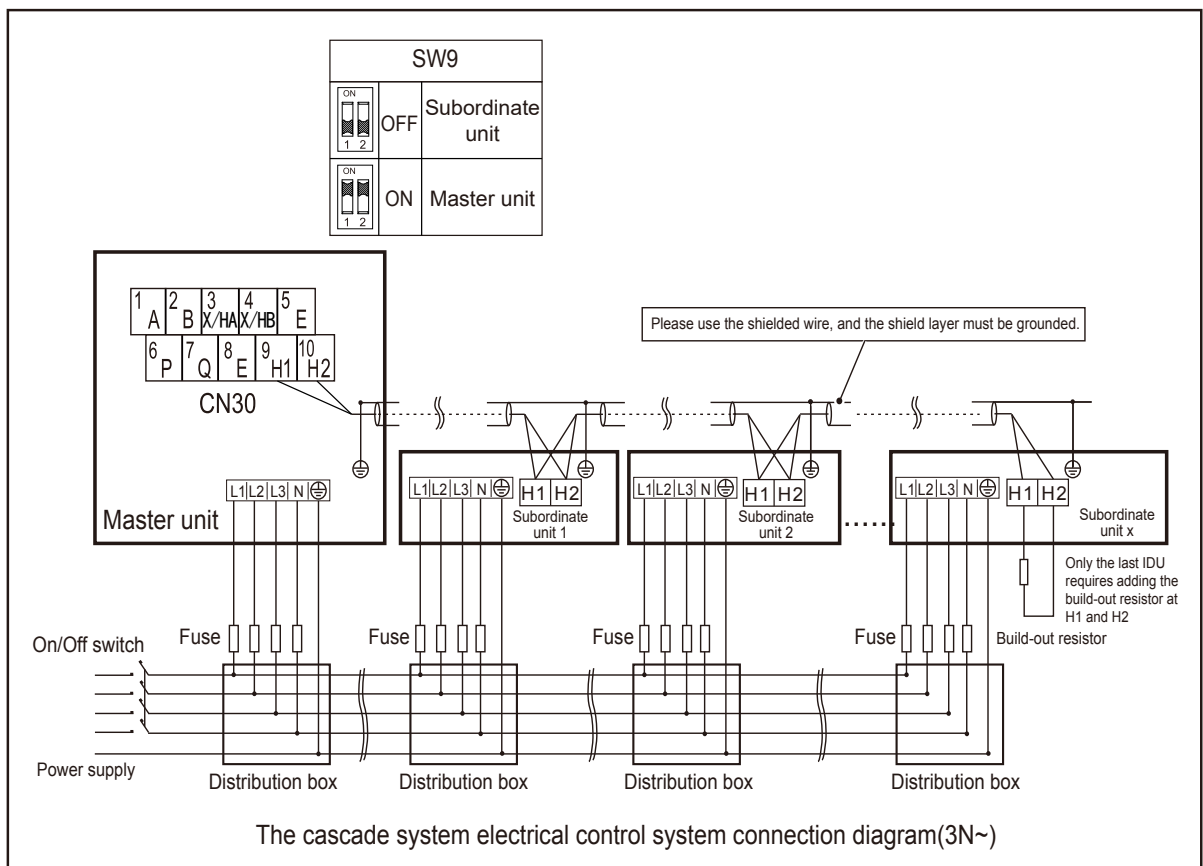
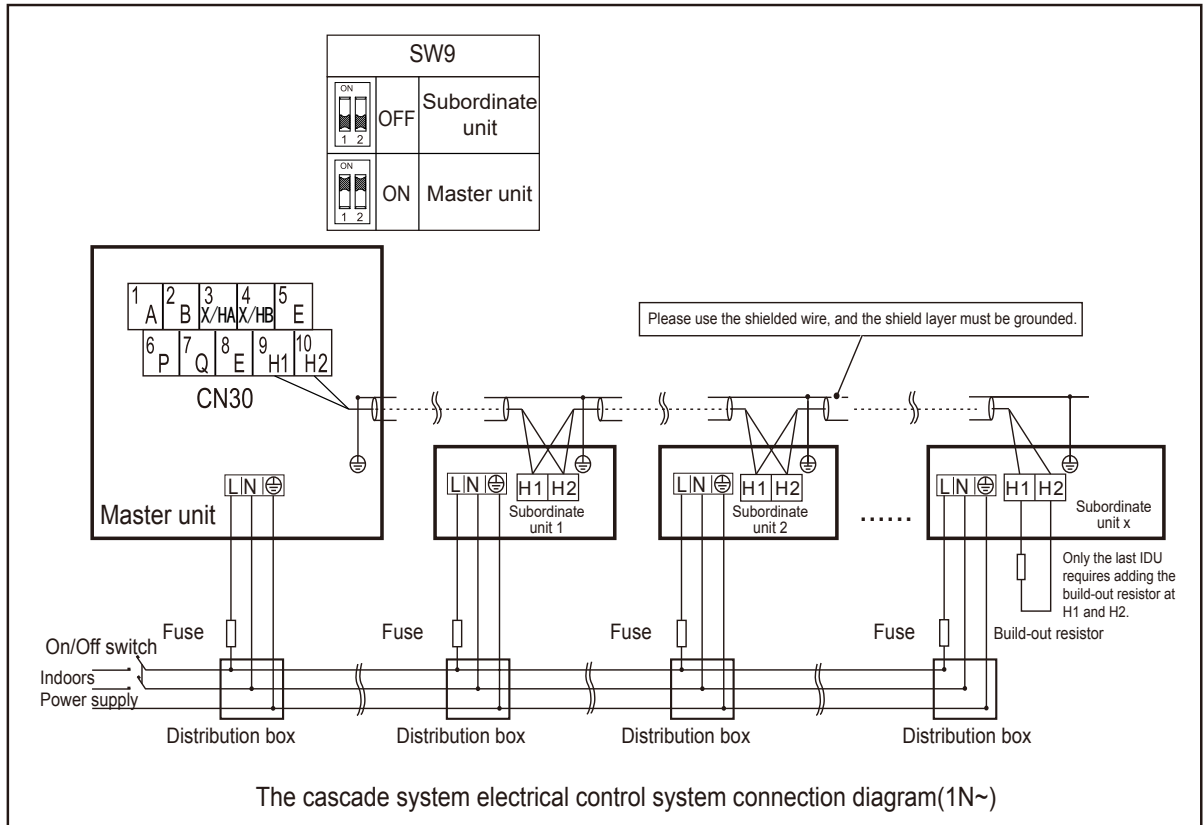

⚠ CAUTION

1. The cascade function of the system only supports 6 machines at most.
2. In order to ensure the success of automatic addressing, all machines must be connected to the same power supply and powered on uniformly.
3. Only the Master unit can connect the controller, and you must put the SW9 to "on" of the master unit, the subordinate unit cannot connect to the controller.
4. Please use shielded wire, and the shield layer must be grounded.

When connecting to the power supply terminal, use the circular wiring terminal with the insulation casing (see Figure 9.1). Use a power cord that conforms to the specifications and connect the power cord firmly. To prevent the cord from being pulled out by external force, make sure it is fixed securely.

If circular wiring terminal with the insulation casing cannot be used, please make sure that:

- Do not connect two power cords with different diameters to the same power supply terminal (this may cause overheating of wires due to loose wiring.) (See Figure 9.2).

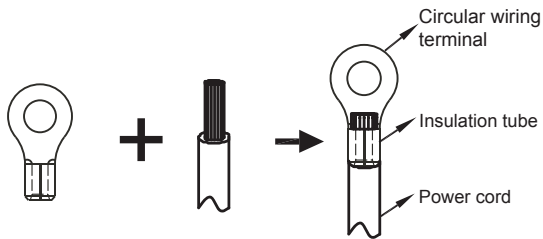

Figure 9.1

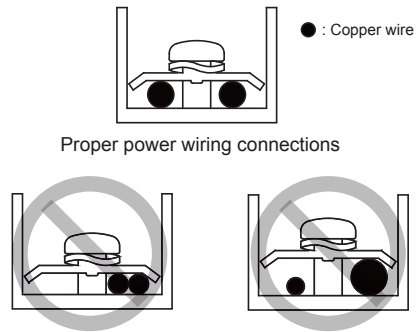

Figure 9.2

Power Cord Connection of cascade system

- Use a dedicated power supply for the indoor unit that is different from the power supply for the outdoor unit.
- Use the same power supply, circuit breaker and leakage protective device for the indoor units connected to the same outdoor unit.

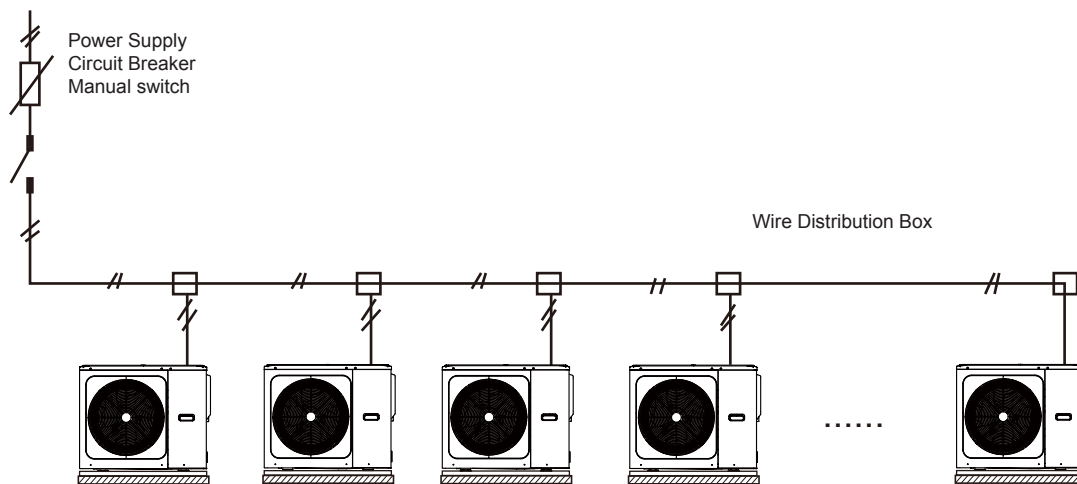

Figure 9.3

9.6.6 Connection for other components

Units 5-16kW

See 9.2.1 for detailed port description.

Ports provide the control signal to the load. There are two kinds of control signal port:

Type 1: Dry connector without voltage.

Type 2: Port provide the signal with 220V voltage. If the current of load is $<0.2A$, load can connect to the port directly. If the current of load is $\geq 0.2A$, the AC contactor is required to connect to the load.

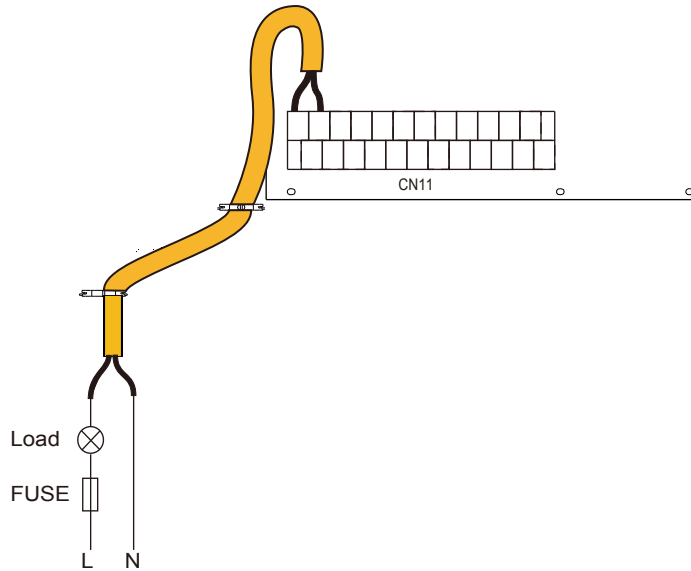

Type 1

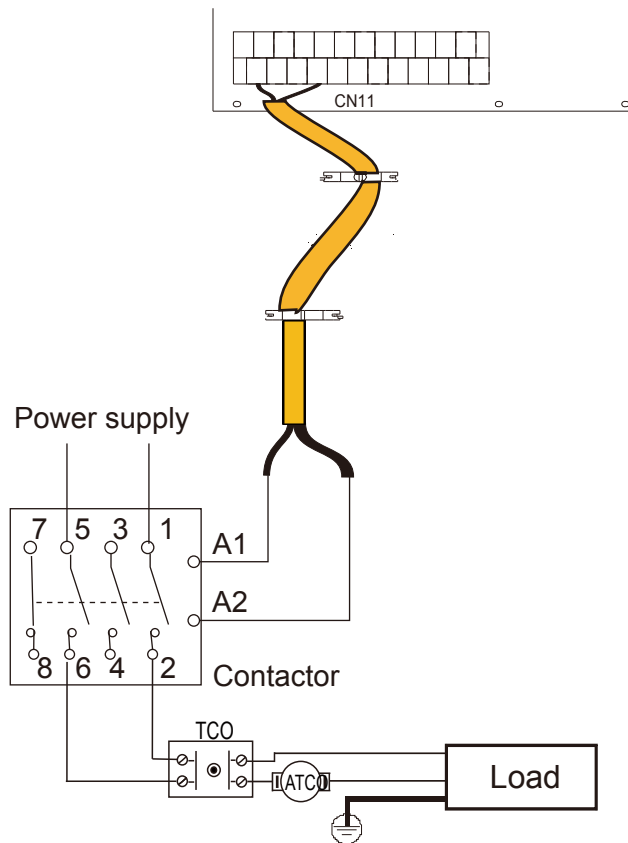

Type 2

Control signal port of hydraulic module: The CN11 contains terminals for 3-way valve, pump, booster heater, etc. The parts wiring is illustrated below:

1) For additional heat source control(AHS):

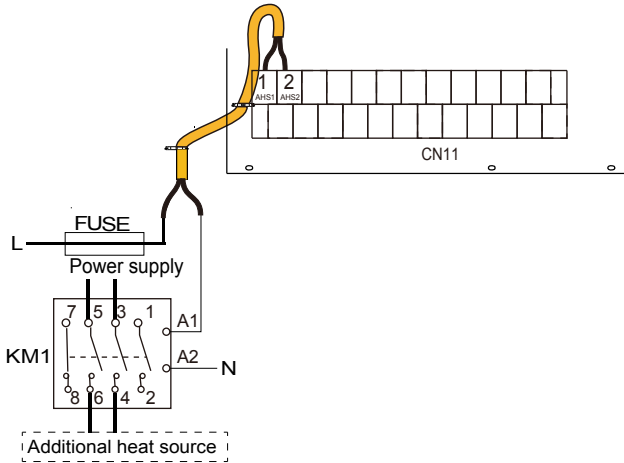

Voltage	220-240VAC
Maximum running current(A)	0.2
Wiring size(mm ²)	0.75
Control port signal type	Type 2

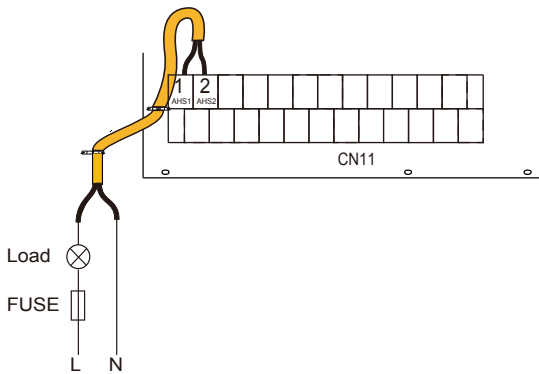

Voltage	220-240VAC
Maximum running current(A)	0.2
Wiring size(mm ²)	0.75
Control port signal type	Type 1

⚠ WARNING

This part only applies to Basic. For Customized, because there is an interval backup heater in the unit, the hydraulic module should not be connected to any additional heat source.

2) For 3-way valve SV1, SV2 and SV3:

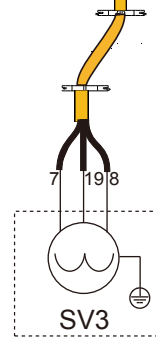
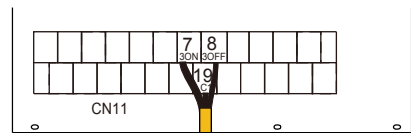
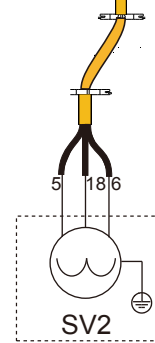
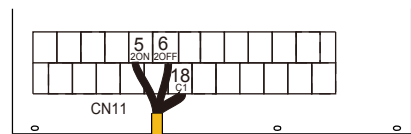
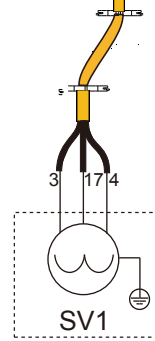
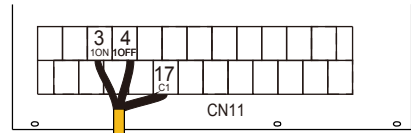

Voltage	220-240VAC
Maximum running current(A)	0.2
Wiring size(mm ²)	0.75
Control port signal type	Type 2

a) Procedure

- Connect the cable to the appropriate terminals as shown in the picture.
- Fix the cable securely.

3) For outside pump :

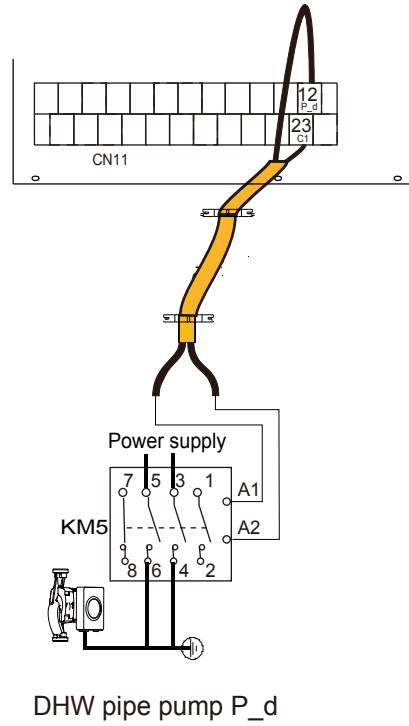
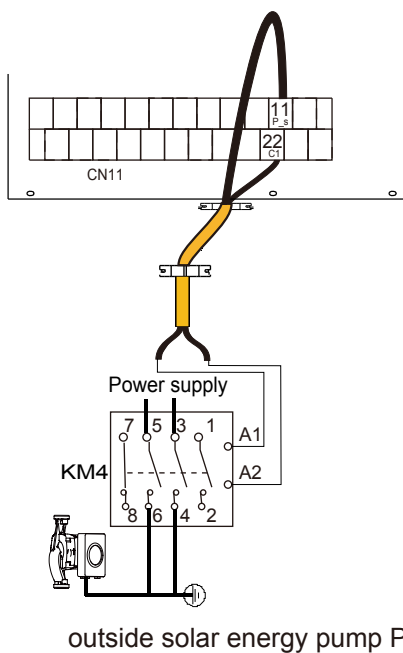
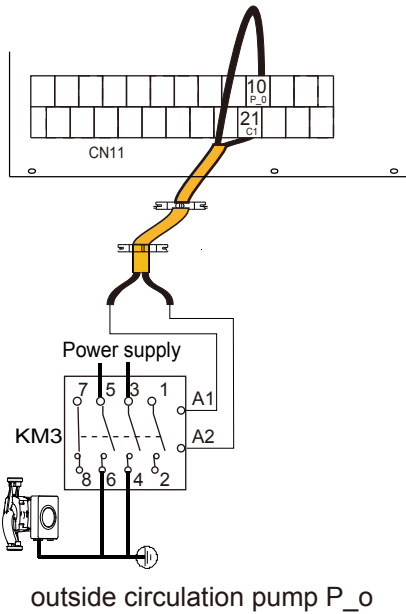
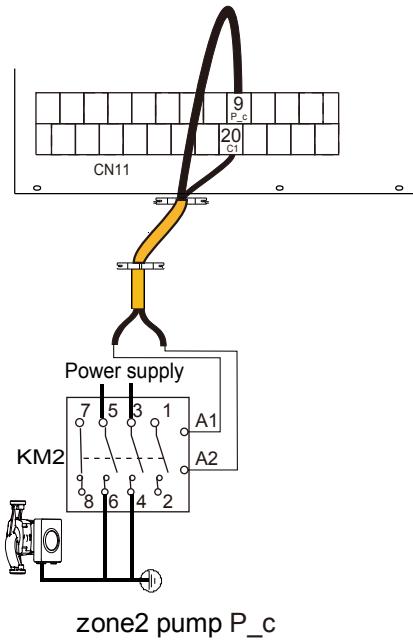

Voltage	220-240VAC
Maximum running current(A)	0.2
Wiring size(mm ²)	0.75
Control port signal type	Type 2

a) Procedure

- Connect the cable to the appropriate terminals as shown in the picture.
- Fix the cable securely.

4) For alarm or Defrost run(P_x):

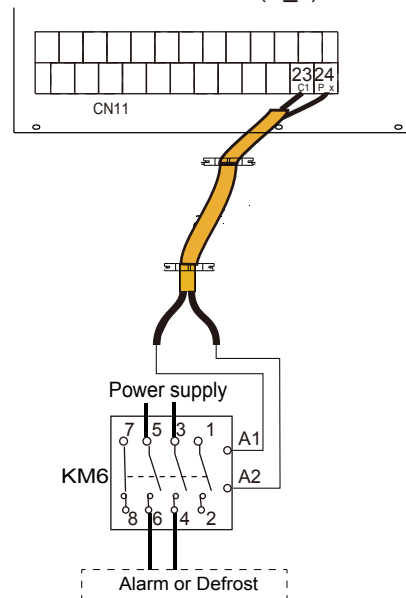

Voltage	220-240VAC
Maximum running current(A)	0.2
Wiring size(mm ²)	0.75
Control port signal type	Type 2

a) Procedure

- Connect the cable to the appropriate terminals as shown in the picture.
- Fix the cable securely.

5) For tank booster heater(TBH):

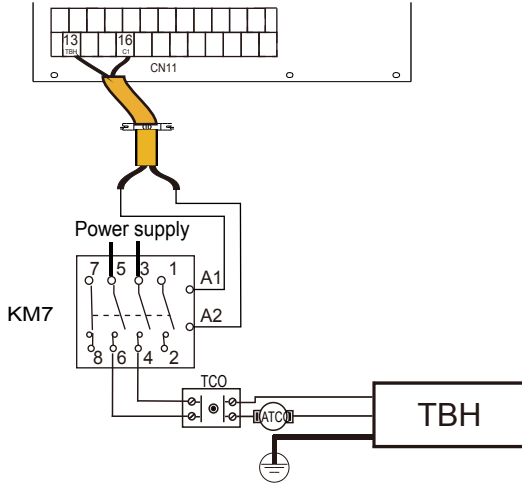

6) For internal backup heater (IBH)

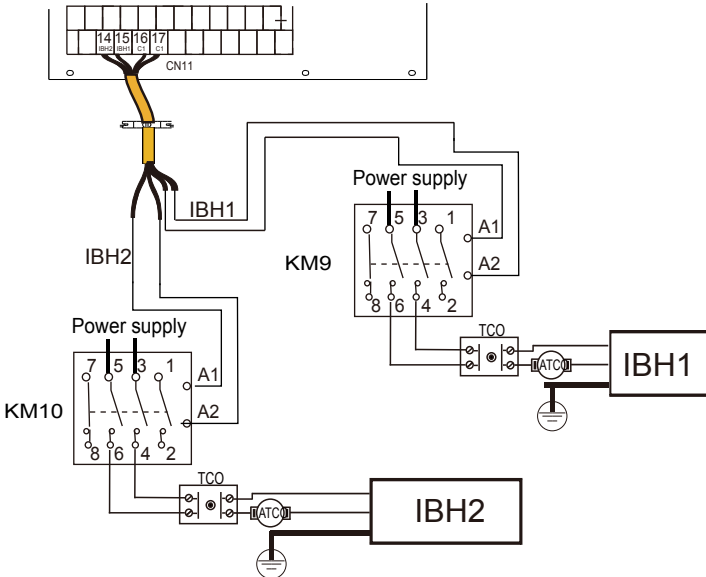
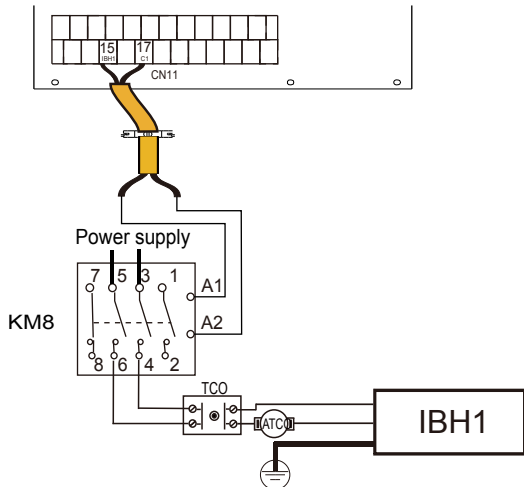

Voltage	220-240VAC
Maximum running current(A)	0.2
Wiring size(mm ²)	0.75
Control port signal type	Type 2

NOTE

- The unit only sends an ON/OFF signal to the heater.
- IBH2 cannot be wired independently.

7) For room thermostat:

Room thermostat (Low voltage) : "POWER IN" provide the voltage to the RT.

NOTE

The room thermostat must be low voltage.

Room thermostat (Low voltage):

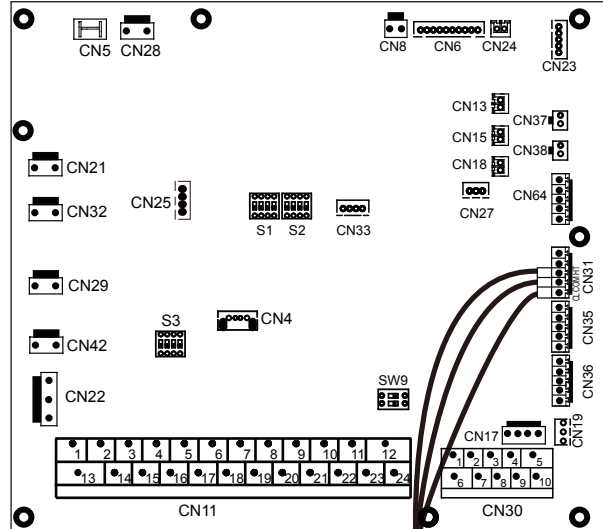

Method A
(Mode set control)

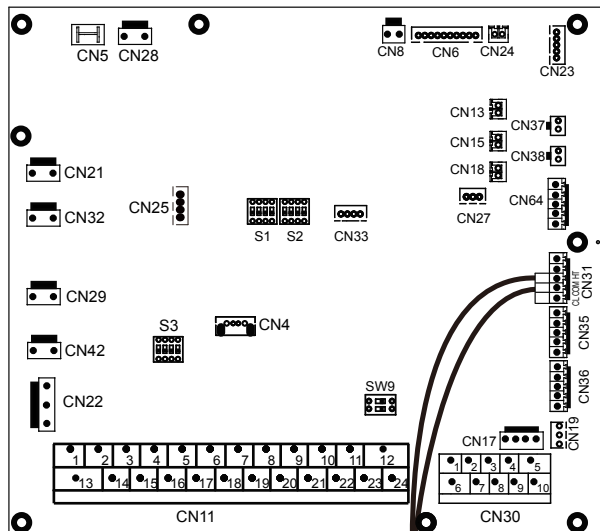
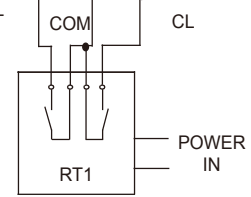

Method B
(One zone control)

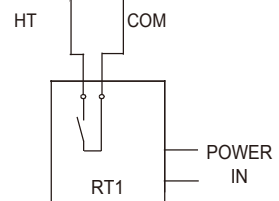

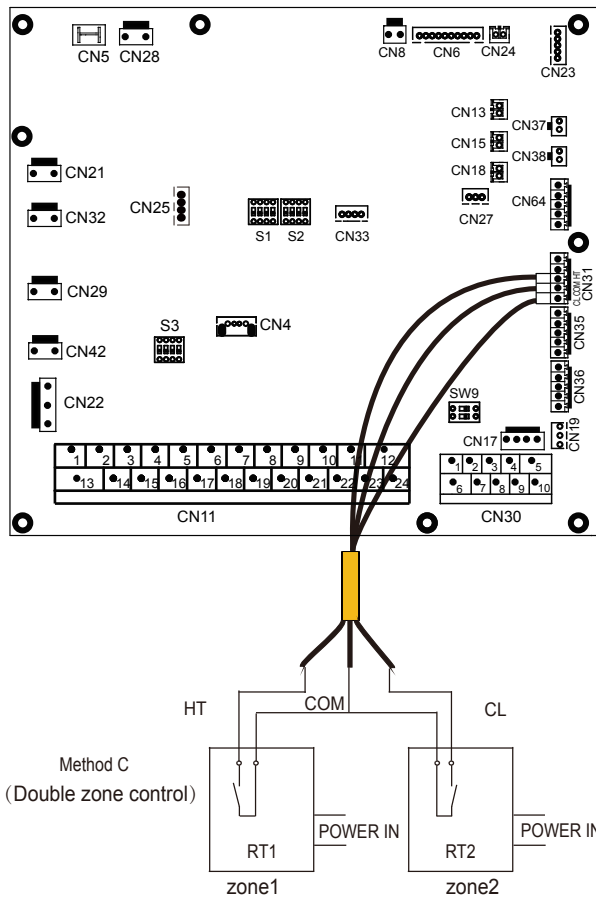

There are three methods for connecting the thermostat cable (as described in the picture above) and it depends on the application.

• **Method A (Mode set control)**

RT can control heating and cooling individually, like the controller for 4-pipe FCU. When the hydraulic module is connected with the external temperature controller, user interface FOR SERVICEMAN set ROOM THERMOSTAT to MODE SET:

A.1 When unit detect voltage is 12VDC between CL and COM, the unit operates in the cooling mode.

A.2 When unit detect voltage is 12VDC between HT and COM, the unit operates in the heating mode.

A.3 When unit detect voltage is 0VDC for both side(CL-COM, HT-COM) the unit stop working for space heating or cooling.

A.4 When unit detect voltage is 12VDC for both side(CL-COM, HT-COM) the unit working in cooling mode.

• **Method B (One zone control)**

RT provide the switch signal to the unit. User interface FOR SERVICEMAN set ROOM THERMOSTAT to ONE ZONE:

B.1 When the detected unit voltage is 12VDC between HT and COM, units turns on.

B.2 When the detected unit voltage is 0VDC between HT and COM, units turns off.

• **Method C (Double zone control)**

Hydraulic Module is connected with two room thermostat, while user interface FOR SERVICEMAN set ROOM THERMOSTAT to DOUBLE ZONE:

C.1 When unit detect voltage is 12VDC between HT and COM, zone1 turn on. When unit detect voltage is 0VDC between HT and COM, zone1 turns off.

C.2 When unit detect voltage is 12VDC between CL and COM, zone2 turn on according to climate temp curve. When unit detect voltage is 0V between CL and COM, zone2 turn off.

C.3 When HT-COM and CL-COM are detected as 0VDC, unit turns off.

C.4 when HT-COM and CL-COM are detected as 12VDC, both zone1 and zone2 turn on.

NOTE

- The wiring of the thermostat should correspond to the settings of the user interface.
- Power supply of machine and room thermostat must be connected to the same Neutral Line .
- When ROOM THERMOSTAT is not set to NON, the indoor temperature sensor Ta can't be set to valid.
- Zone 2 can only operate in heating mode, When cooling mode is set on user interface and zone1 is OFF, "CL" in zone2 closes, system still keeps 'OFF'. While installing, the wiring of thermostats for zone1 and zone2 must be correct.

a) Procedure

- Connect the cable to the appropriate terminals as shown in the picture.
- Fix the cable with cable ties to the cable tie mountings to prevent excess stress.

8) For solar energy input signal (low voltage):

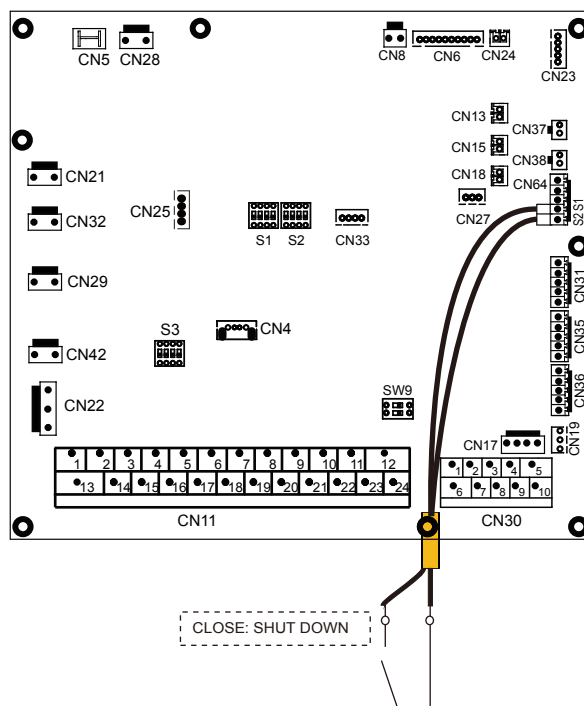

9) For remote shut down:

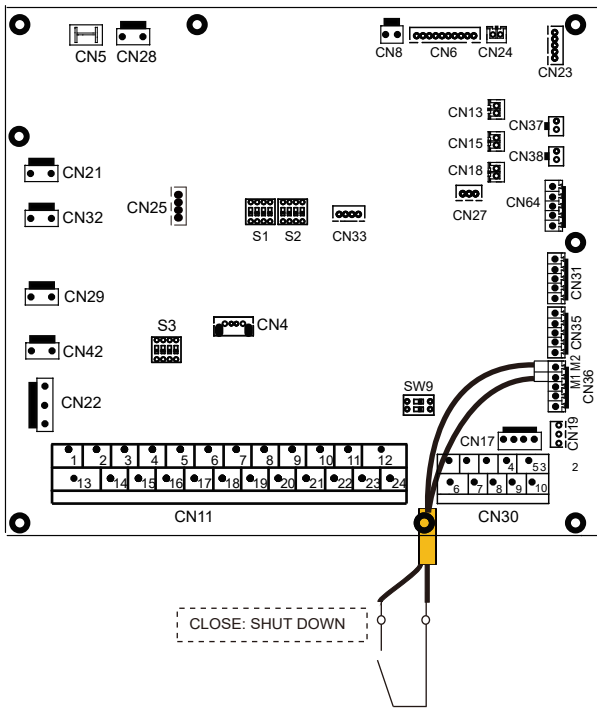

10) For smart grid:

The unit has smart grid function, there are two ports on PCB to connect SG signal and EVU signal as following:

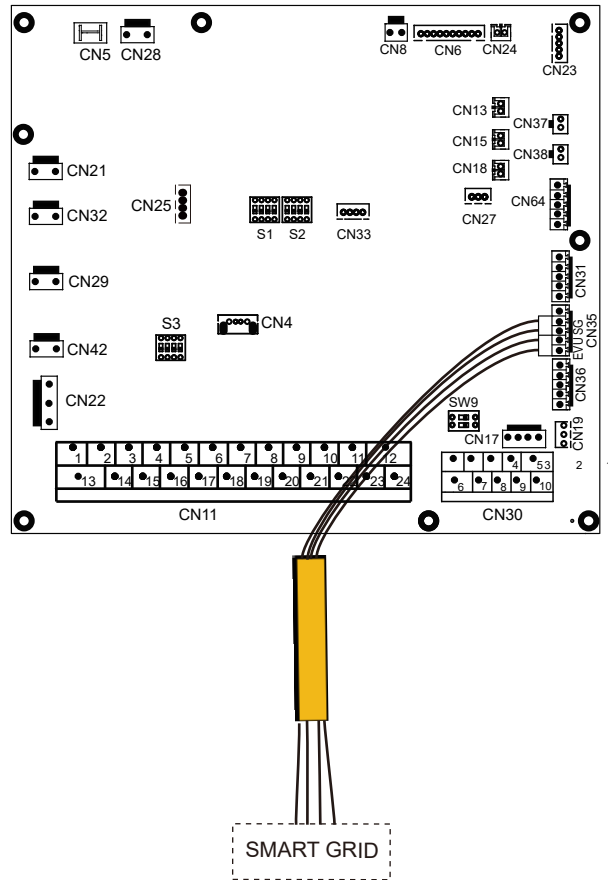

1) SG=ON, EVU=ON.

If DHW mode is set available:

- The heat pump will first operate in DHW mode.
- TBH is set to available, If $T5 < 69\text{ }^{\circ}\text{C}$, TBH will be turned on forcibly (The heat pump and TBH can operate at the same time.); if $T5 \geq 70\text{ }^{\circ}\text{C}$, TBH will turn off. (DHW=Domestic Hot Water, T5S is the set water tank temperature.)
- TBH is set to unavailable and IBH is set available for DHW mode, as long as $T5 < 59\text{ }^{\circ}\text{C}$, IBH will be turned on forcibly (The heat pump and TBH can operate at the same time.); if $T5 \geq 60\text{ }^{\circ}\text{C}$, IBH will turn off.

2) SG=OFF, EVU=ON.

If DHW mode is set available and DHW mode is set ON:

- The heat pump first will operate in DHW mode.
- If TBH is set to available and DHW mode is set to ON, If $T5 < T5S - 2$, the TBH will be turned on (The heat pump and IBH can operate at the same time.); if $T5 \geq T5S + 3$, the TBH will be turned off.
- If TBH is set to unavailable and IBH is set to available for DHW mode, If $T5 < T5S - dT5_ON$, IBH will be turned on. The heat pump and IBH can operate at the same time.); if $T5 \geq \text{Min}(T5S + 3, 60)$, the IBH will turn off.

3) SG=OFF, EVU=OFF.

The unit will operate normally.

4) SG=ON, EVU=OFF.

Heat pump, IBH, TBH will turn off immediately.

10 START-UP AND CONFIGURATION

The unit should be configured by the installer to match the installation environment (outdoor climate, installed options, etc.) and user expertise.

CAUTION

It is important that all information in this chapter is read sequentially by the installer and that the system is configured as applicable.

10.1 Initial start-up at low outdoor ambient temperature

During initial start-up and when water temperature is low, it is important that the water is heated gradually. Failure to do so may result in concrete floors cracking due to rapid temperature change. Please contact the responsible cast concrete building contractor for further details.

To do so, the preheating function for floor can be used. (Refer to "SPECIAL FUNCTION" in "FOR SERVICEMAN")

10.2 Pre-operation checks

Checks before initial start-up.

DANGER

Switch off the power supply before making any connections.

After the installation of the unit, check the following before switching on the circuit breaker:

- **Field wiring:** Make sure that the field wiring between the local supply panel and unit and valves (when applicable), unit and room thermostat (when applicable), unit and domestic hot water tank, and unit and backup heater kit have been connected according to the instructions described in the chapter 9.6 "Field wiring", according to the wiring diagrams and to local laws and regulations.
- **Fuses, circuit breakers, or protection devices.** Check that the fuses or the locally installed protection devices are of the size and type specified in 15 "TECHNICAL SPECIFICATIONS". Make sure that no fuses or protection devices have been bypassed.
- **Backup heater circuit breaker:** Do not forget to turn on the backup heater circuit breaker in the switchbox (it depends on the backup heater type). Refer to the wiring diagram.
- **Booster heater circuit breaker:** Do not forget to turn on the booster heater circuit breaker (applies only to units with optional domestic hot water tank installed).
- **Ground wiring:** Make sure that the ground wires have been connected properly and that the ground terminals are tightened.
- **Internal wiring:** Visually check the switch box for loose connections or damaged electrical components.
- **Mounting:** Check that the unit is properly mounted, to avoid abnormal noises and vibrations when starting up the unit.
- **Damaged equipment:** Check the inside of the unit for damaged components or squeezed pipes.
- **Refrigerant leak:** Check the inside of the unit for refrigerant leakage. If there is a refrigerant leak, call your local dealer.
- **Power supply voltage:** Check the power supply voltage on the local supply panel. The voltage must correspond to the voltage on the identification label of the unit.
- **Air purge valve:** Make sure the air purge valve is open (at least 2 turns).
- **Shut-off valves:** Make sure that the shut-off valves are fully open.

10.3 Failure diagnosis at first installation

- If nothing is displayed on the user interface, it is necessary to check for any of the following abnormalities before diagnosing possible error codes.
 - Disconnection or wiring error (between power supply and unit and between unit and user interface).
 - The fuse on the PCB may be broken.
- If the user interface shows "E8" or "E0" as an error code, there is a possibility that there is air in the system, or the water level in the system is less than the required minimum.
- If the error code E2 is displayed on the user interface, check the wiring between the user interface and unit.
More error code and failure causes can be found in 14.3 "Error codes".

10.4 Installation Manual

10.4.1 Safety precaution

- Read the safety precautions carefully before installing the unit.
- Stated below are important safety issues that must be obeyed.
- Confirm that there are no abnormal phenomena during the test operation after installation. Once confirmed, give the manual to the user.
- Meaning of marks:

WARNING

Means improper handling may lead to personal death or severe injury.

CAUTION

Means improper handling may lead to personal injury or property loss.

WARNING

Please entrust the distributor or professionals to install the unit.

Installation by other persons may lead to imperfect installation, electric shock or fire.

Strictly follow this manual.

Improper installation may lead to electric shock or fire.

Reinstallation must be performed by professionals.

Improper installation may lead to electric shock or fire.

Do not disassemble your air conditioner at will.

A random disassembly may cause abnormal operation or heating, which may result in fire.

CAUTION

The wired controller should be installed indoors and not be exposed to direct sunlight.

Do not install the unit in a place vulnerable to leakage of flammable gases.

Once flammable gases are leaked and left around the wired controller, fire may occur.

The wiring should adapt to the wired controller current. Otherwise, electric leakage or heating may occur and result in fire.

The specified cables must be used for the wiring. No external force may be applied to the terminal.

Otherwise, the wire may be cut and become hot, which may result in a fire.

CAUTION

Do not place the wired remote controller near lamps, to avoid disturbing the remote signal of the controller.

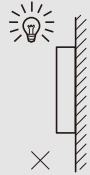

10.4.2 Other Precautions

10.4.2.1. Installation location

Do not install the unit in a place with large amounts of oil, steam, sulfide gas. Otherwise, the product may deform and fail.

10.4.2.2 Preparation before installation

1) Check whether the following assemblies are complete.

No.	Name	Qty.	Remarks
1	Wired Controller	1	
2	Cross round head wood mounting screw	3	For Mounting on the Wall
3	Cross round head mounting screw	2	For Mounting on the Electrical Switch Box
4	Installation and Owner's Manual	1	
5	Plastic bolt	2	This accessory is used when install the centralized control inside the electric cabinet
6	Plastic expansion pipe	3	For mounting on the Wall

10.4.2.3 Note for installation of wired controller:

- 1) This installation manual contains information about the procedure to install the Wired Remote Controller. Please refer to Indoor Unit Installation Manual for connection between Wired Remote Controller and Indoor Unit.
- 2) Circuit of Wired Remote Controller is low voltage circuit. Never connect it with a standard 220V/380V circuit or put it into a same Wiring Tube with the circuit.
- 3) The shielded cable must be connected stable to the ground, or transmission may fail.
- 4) Do not attempt to extend the shielded cable by cutting, if it is necessary, use Terminal Connection Block to connect.
- 5) After finishing connection, do not use Megger to have the insulation check for the signal wire.
- 6) Cut off the power supply when installing the wired controller.

10.4.3 Installation procedure and matching setting of wired controller

10.4.3.1 Structure size figure

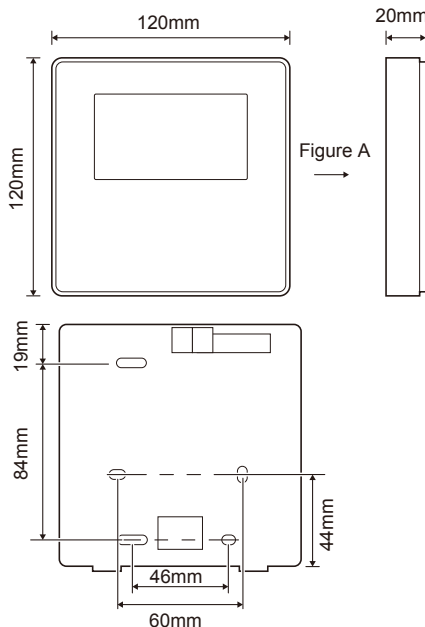

10.4.3.2 Wiring

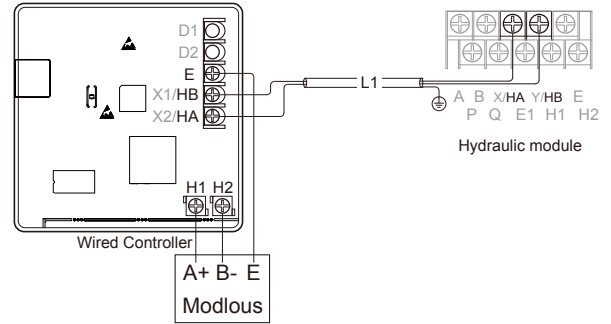

Input Voltage (HA/HB)	18V DC
Wiring size	0.75mm ²
Wiring type	2-core shielded twisted pair cable
Wiring length	L1<50m

The rotating coded switch S3(0-F) on the main control board of hydraulic module is used for set the modbus address.

By default the units have this coded switch positioned=0, but this corresponds to the modbus address 16, while the others positions corresponds the number, e.g. pos=2 is address 2, pos=5 is address 5.

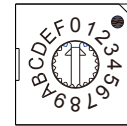

10.4.3.3 Back cover installation

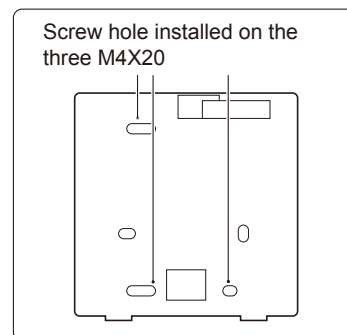
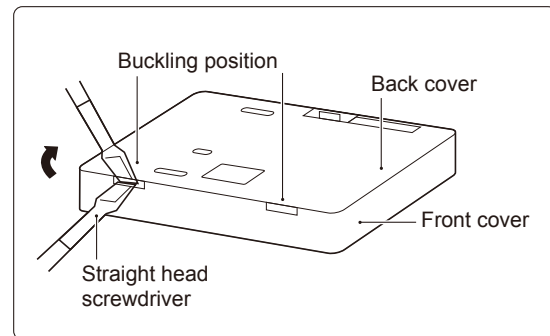

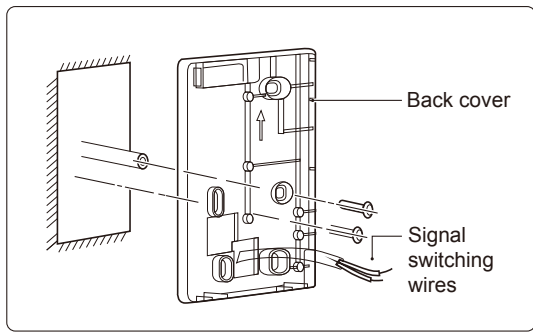
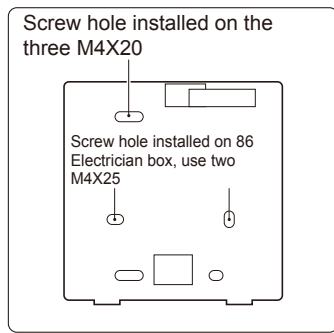

- 1) Use straight head screwdriver to insert in the buckling position in the bottom of wired controller, and spin the screwdriver to take down the back cover. (Pay attention to spinning direction, otherwise will damage the back cover!)
- 2) Use three M4X20 screws to directly install the back cover on the wall.
- 3) Use two M4X25 screws to install the back cover on the 86 electrician box, and use one M4X20 screws for fixing on the wall.
- 4) Adjust the length of two plastic screw bars in the accessory to be standard length from the electrical box screw bar to the wall. Make sure while installing the screw bar to the wall, making it as flat as the wall.
- 5) Use cross head screws to fix the wired controller bottom cover in the wall through the screw bar. Make sure the wired controller bottom cover is on the same level after installation, and then install the wired controller back to the bottom cover.
- 6) Over fastening the screw will lead to deformation of back cover.

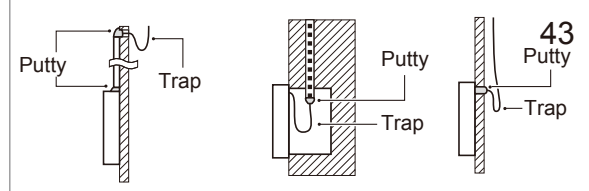
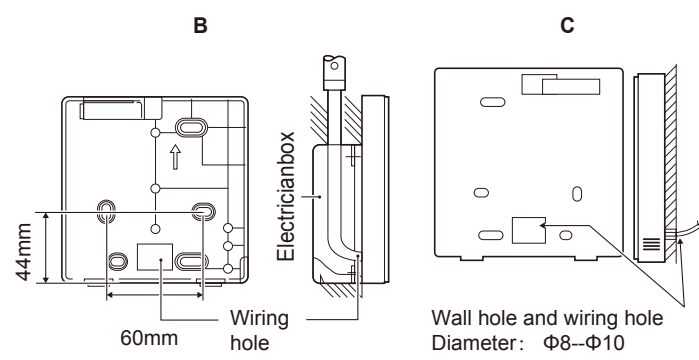
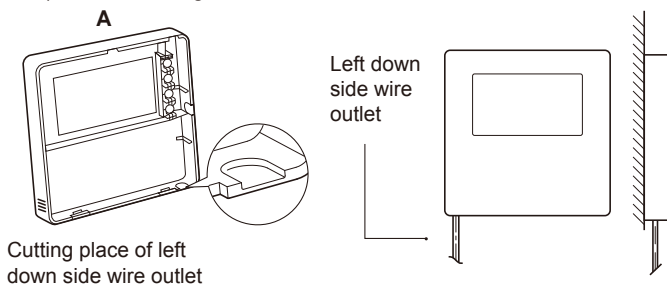

Avoid the water enter into the wired remote controller, use trap and putty to seal the connectors of wires during wiring installation.

10.4.4 Front cover installation

After adjusting the front cover and then buckle the front cover; avoid clamping the communication switching wire during installation.

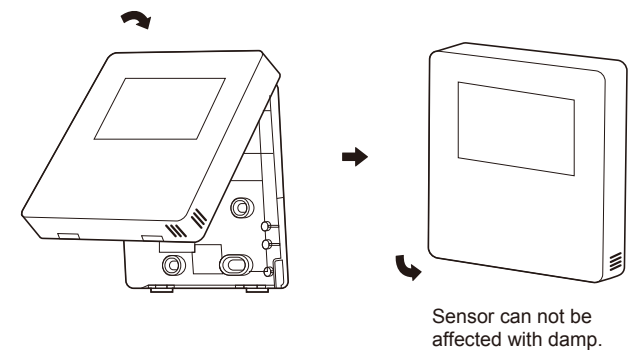

Correct install the back cover and firmly buckle the front cover and back cover, otherwise will make the front cover drop off.

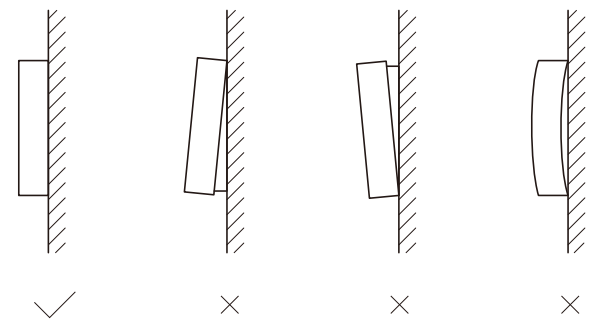

10.5 Field settings

The unit should be configured to match the installation environment (outdoor climate, installed options, etc.) and user demand. A number of field settings are available. These settings are accessible and programmable through "FOR SERVICEMAN" in user interface.

Powering on the unit

When the unit is powered on, "1%~99%" is displayed on the user interface. During this process the user interface cannot be operated.

Procedure

To change one or more field settings, please refer to "FOR SERVICEMAN" for details

NOTE

Temperature values displayed on the wired controller (user interface) are in °C.

11 MENU STRUCTURE : OVERVIEW

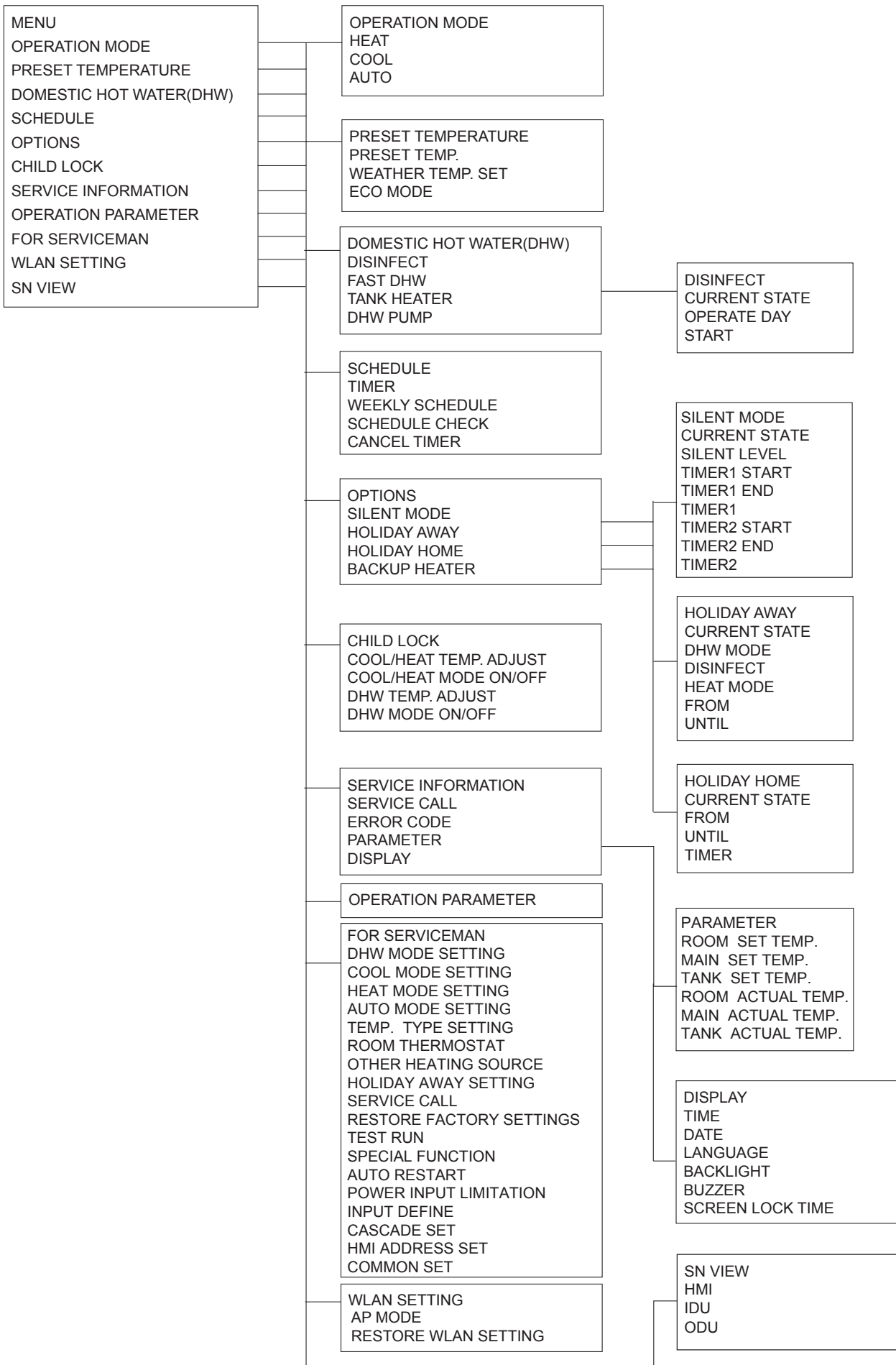

FOR SERVICEMAN
 1 DHW MODE SETTING
 2 COOL MODE SETTING
 3 HEAT MODE SETTING
 4 AUTO MODE SETTING
 5 TEMP. TYPE SETTING
 6 ROOM THERMOSTAT
 7 OTHER HEATING SOURCE
 8 HOLIDAY AWAY SETTING
 9 SERVICE CALL
 10 RESTORE FACTORY SETTINGS
 11 TEST RUN
 12 SPECIAL FUNCTION
 13 AUTO RESTART
 14 POWER INPUT LIMITATION
 15 INPUT DEFINE
 16 CASCADE SET
 17 HMI ADDRESS SET
 18 COMMON SET

1 DHW MODE SETTING
 1.1 DHW MODE
 1.2 DISINFECT
 1.3 DHW PRIORITY
 1.4 PUMP_D
 1.5 DHW PRIORITY TIME SET
 1.6 dT5_ON
 1.7 dT1S5
 1.8 T4DHWMAX
 1.9 T4DHWMIN
 1.10 t_INTERVAL_DHW
 1.11 T5S_DISINFECT
 1.12 t_DI_HIGHTEMP
 1.13 t_DI_MAX
 1.14 t_DHWHP_RESTRICT
 1.15 t_DHWHP_MAX
 1.16 PUMP_D TIMER
 1.17 PUMP_D RUNNING TIME
 1.18 PUMP_D DISINFECT
 1.19 ACS FUNCTION

2 COOL MODE SETTING
 2.1 COOL MODE
 2.2 t_T4_FRESH_C
 2.3 T4CMAX
 2.4 T4CMIN
 2.5 dT1SC
 2.6 dTSC
 2.7 t_INTERVAL_C
 2.8 T1SetC1
 2.9 T1SetC2
 2.10 T4C1
 2.11 T4C2
 2.12 ZONE1 C-EMISSION
 2.13 ZONE2 C-EMISSION

3 HEAT MODE SETTING
 3.1 HEAT MODE
 3.2 t_T4_FRESH_H
 3.3 T4HMAX
 3.4 T4HMIN
 3.5 dT1SH
 3.6 dTSH
 3.7 t_INTERVAL_H
 3.8 T1SetH1
 3.9 T1SetH2
 3.10 T4H1
 3.11 T4H2
 3.12 ZONE1 H-EMISSION
 3.13 ZONE2 H-EMISSION
 3.14 FORCE DEFROST

4 AUTO MODE SETTING
 4.1 T4AUTOCMIN
 4.2 T4AUTOHMAX

5 TEMP. TYPE SETTING
 5.1 WATER FLOW TEMP.
 5.2 ROOM TEMP.
 5.3 DOUBLE ZONE

6 ROOM THERMOSTAT
 6.1 ROOM THERMOSTAT
 6.2 MODE SET PRIORITY

7 OTHER HEATING SOURCE
 7.1 IBH FUNCTION
 7.2 IBH LOCATE
 7.3 dT1_IBH_ON
 7.4 t_IBH_DELAY
 7.5 T4_IBH_ON
 7.6 P_IBH1
 7.7 P_IBH2
 7.8 AHS FUNCTION
 7.9 AHS_PUMPI CONTROL
 7.10 dT1_AHS_ON
 7.11 t_AHS_DELAY
 7.12 T4_AHS_ON
 7.13 EnSWITCHPDC
 7.14 GAS_COST
 7.15 ELE_COST
 7.16 MAX_SETHEATER
 7.17 MIN_SETHEATER
 7.18 MAX_SIGHEATER
 7.19 MIN_SIGHEATER
 7.20 TBH FUNCTION
 7.21 dT5_TBH_OFF
 7.22 t_TBH_DELAY
 7.23 T4_TBH_ON
 7.24 P_TBH
 7.25 SOLAR FUNCTION
 7.26 SOLAR CONTROL
 7.27 DELTASOL

8 HOLIDAY AWAY SETTING
 8.1 T1S_H.A._H
 8.2 T5S_H.A._DHW

9 SERVICE CALL
 PHONE NO.
 MOBILE NO.

10 RESTORE FACTORY SETTINGS

11 TEST RUN

12 SPECIAL FUNCTION

13 AUTO RESTART
 13.1 COOL/HEAT MODE
 13.2 DHW MODE

14 POWER INPUT LIMITATION
 14.1 POWER INPUT LIMITATION

15 INPUT DEFINE
 15.1 M1M2
 15.2 SMART GRID
 15.3 T1T2
 15.4 Tbt
 15.5 P_X PORT

16 CASCADE SET
 16.1 PER_START
 16.2 TIME_ADJUST
 16.3 ADDRESS RESET

17 HMI ADDRESS SET
 17.1 HMI SET
 17.2 HMI ADDRESS FOR BMS
 17.3 STOP BIT

18 COMMON SET
 18.1 t_DELAY PUMP
 18.2 t1_ANTILOCK PUMP
 18.3 t2_ANTILOCK PUMP RUN
 18.4 t1_ANTILOCK SV
 18.5 t2_ANTILOCK SV RUN
 18.6 Ta_adj.
 18.7 F-PIPE LENGTH
 18.8 PUMP_I SILENT OUTPUT

11.1 Setting parameters

The parameters related to this chapter are shown in the table below.

Order number	Code	State	Default	Unit
1.1	DHW MODE	Enable or disable the DHW mode:0=NON,1=YES	1	/
1.2	DISINFECT	Enable or disable the disinfect mode:0=NON,1=YES	1	/
1.3	DHW PRIORITY	Enable or disable the DHW priority mode:0=NON,1=YES	1	/
1.4	PUMP_D	Enable or disable the DHW pump mode:0=NON,1=YES	0	/
1.5	DHW PRIORITY TIME SET	Enable or disable the DHW priority time set:0=NON,1=YES	0	/
1.6	dT5_ON	The temperature difference for starting the heat pump	10	°C
1.7	dT1S5	The difference value between Twout and T5 in DHW mode	10	°C
1.8	T4DHWMAX	The maximum ambient temperature that the heat pump can operate at for domestic water heating	43	°C
1.9	T4DHWMIN	The minimum ambient temperature that the heat pump can operate for domestic water heating	-10	°C
1.10	t_INTERVAL_DHW	The start time interval of the compressor in DHW mode.	5	MIN
1.11	T5S_DISINFECT	The target temperature of water in the domestic hot water tank in the DISINFECT function.	65	°C
1.12	t_DI_HIGHTEMP	The time that the highest temperature of water in the domestic hot water tank in the DISINFECT function will last.	15	°C
1.13	t_DI_MAX	The maximum time that disinfection will last.	210	MIN
1.14	t_DHWHP_RESTRICT	The operation time for the space heating/cooling operation.	30	°C
1.15	t_DHWHP_MAX	The maximum running time of heat pump in DHW PRIORITY mode.	90	MIN
1.16	PUMP_D TIMER	Enable or disable the DHW pump run as timed and keeps running for PUMP RUNNING TIME:0=NON,1=YES	1	/
1.17	PUMP_D RUNNING TIME	The certain time that the DHW pump will keep running.	5	MIN
1.18	PUMP_D DISINFECT	Enable or disable the DHW pump operates when the unit is in disinfect mode and T5≥T5S_DI-2:0=NON,1=YES	1	/
1.19	ACS FUNCTION	Enable or disable the second water tank control T5_2: 0=NON,1=YES	0	/
2.1	COOL MODE	Enable or disable the cooling mode:0=NON,1=YES	1	/
2.2	t_T4_FRESH_C	The refresh time of climate related curves for cooling mode	0.5	hours
2.3	T4CMAX	The highest ambient operation temperature for cooling mode	52	°C
2.4	T4CMIN	The lowest ambient operating temperature for cooling mode	10	°C
2.5	dT1SC	The temperature difference between T1 and T1S(the set water temperature) for starting the heat pump	5	°C
2.6	dTSC	The temperature difference between actual room temperature Ta and the set room temperature Tas for starting the heat pump.	2	°C
2.7	t_INTERVAL_C	The start time interval of the compressor in cooling mode	5	min
2.8	T1SetC1	The setting temperature 1 of climate related curves for cooling mode.	10	°C
2.9	T1SetC2	The setting temperature 2 of climate related curves for cooling mode.	16	°C
2.10	T4C1	The ambient temperature 1 of climate related curves for cooling mode.	35	°C
2.11	T4C2	The ambient temperature 2 of climate related curves for cooling mode.	25	°C
2.12	ZONE1 C-EMISSION	The terminal type of zone 1 for cooling mode: 0=FCU(fan coil unit), 1=RAD.(radiator), 2=FHL(floor heating loop)	0	/
2.13	ZONE2 C-EMISSION	The terminal type of zone 2 for cooling mode: 0=FCU(fan coil unit), 1=RAD.(radiator), 2=FHL(floor heating loop)	0	/
3.1	HEAT MODE	Enable or disable the heating mode	1	/
3.2	t_T4_FRESH_H	The refresh time of climate related curves for heating mode	0.5	hours

Order number	Code	State	Default	Unit
3.3	T4HMAX	The maximum ambient operating temperature for heating mode	25	°C
3.4	T4HMIN	The minimum ambient operating temperature for heating mode	-15	°C
3.5	dT1SH	The temperature difference between T1 and T1S(the set water temperature) for starting the heat pump	5	°C
3.6	dTSH	The temperature difference between actual room temperature Ta and the set room temperature Tas for starting the heat pump	2	°C
3.7	t_INTERVAL_H	The start time interval of the compressor in heating mode	5	min
3.8	T1SetH1	The setting temperature 1 of climate related curves for heating mode	35	°C
3.9	T1SetH2	The setting temperature 2 of climate related curves for heating mode	28	°C
3.10	T4H1	The ambient temperature 1 of climate related curves for heating mode	-5	°C
3.11	T4H2	The ambient temperature 2 of climate related curves for heating mode	7	°C
3.12	ZONE1 H-EMISSION	The terminal type of zone 1 for heating mode: 0=FCU(fan coil unit), 1=RAD.(radiator), 2=FHL(floor heating loop)	1	/
3.13	ZONE2 H-EMISSION	The terminal type of zone 2 for heating mode: 0=FCU(fan coil unit), 1=RAD.(radiator), 2=FHL(floor heating loop)	2	/
3.14	FORCE DEFROST	Enable or disable the FORCE DEFROST function: 0=NON,1=YES	0	/
4.1	T4AUTOCLMIN	The minimum operating ambient temperature for cooling in auto mode	25	°C
4.2	T4AUTOHMAX	The maximum operating ambient temperature for heating in auto mode	17	°C
5.1	WATER FLOW TEMP.	Enable or disable the WATER FLOW TEMP.:0=NON,1=YES	1	/
5.2	ROOM TEMP.	Enable or disable the ROOM TEMP.:0=NON,1=YES	0	/
5.3	DOUBLE ZONE	Enable or disable the ROOM THERMOSTAT DOUBLE ZONE:0=NON,1=YES	0	/
6.1	ROOM THERMOSTAT	Room thermostat type: 0=NON,1=MODESET,2=ONE ZONE 3=DOUBLE ZONE	0	/
6.2	MODE SET PRIORITY	Select the priority mode in ROOM THERMOSTAT: 0=HEAT,1=COOL	0	/
7.1	IBH FUNCTION	Select the mode that IBH (BACKUP HEATER) can run: 0=HEAT+DHW,1=HEAT	0 (DHW=valid) 1 (DHW=invalid)	/
7.2	IBH LOCATE	The installation location of IBH (PIPE LOOP=0)	0	/
7.3	dT1_IBH_ON	The temperature difference between T1S and T1 for starting the backup heater.	5	°C
7.4	t_IBH_DELAY	The time that the compressor has run before starting the first step backup heater.	30	min
7.5	T4_IBH_ON	The ambient temperature for starting the backup heater.	-5	°C
7.6	P_IBH1	Power input of IBH1	0	kW
7.7	P_IBH2	Power input of IBH2	0	kW
7.8	AHS FUNCTION	Enable or disable the AHS (AUXILIARY HEATING SOURCE) function: 0=NON,1=HEAT,2=HEAT+DHW	0	/
7.9	AHS_PUMPI CONTROL	Select the pump operating status when only AHS runs: 0=RUN,1=NOT RUN	0	/
7.10	dT1_AHS_ON	The temperature difference between T1S and T1B for starting the auxiliary heating source	5	°C
7.11	t_AHS_DELAY	The time that the compressor has run before starting the additional heating source	30	min
7.12	T4_AHS_ON	The ambient temperature for starting the additional heating source	-5	°C
7.13	EnSWITCHPDC	Enable or disable the function that heat pump and auxiliary heating source switch automatically based on running cost: 0=NON,1=YES	0	/

Order number	Code	State	Default	Unit
7.14	GAS_COST	Price of gas	0.85	€/m ³
7.15	ELE_COST	Price of electricity	0.20	€/kWh
7.16	MAX_SETHEATER	Maximum setting temperature of additional heating source	80	°C
7.17	MIN_SETHEATER	Minimum setting temperature of additional heating source	30	°C
7.18	MAX_SIGHEATER	The voltage corresponding to the maximum setting temperature of additional heating source	10	V
7.19	MIN_SIGHEATER	The voltage corresponding to the minimum setting temperature of additional heating source	3	V
7.20	TBH FUNCTION	Enable or disable the TBH (TANK BOOSTER HEATER) function: 0=NON,1=YES	1	/
7.21	dT5_TBH_OFF	The temperature difference between T5 and T5S(The set water tank temperature) that turns the booster heater off.	5	°C
7.22	t_TBH_DELAY	The time that the compressor has run before starting the booster heater	30	min
7.23	T4_TBH_ON	The ambient temperature for starting the tank booster heater	5	°C
7.24	P_TBH	Power input of TBH	2	kW
7.25	SOLAR FUNCTION	Enable or disable the SOLAR function: 0=NON,1=ONLY SOLAR, 2=SOLAR+HP (HEAT PUMP)	0	/
7.26	SOLAR CONTROL	The solar pump (pump_s) control method : 0=Tsolar, 1=SL1SL2	0	/
7.27	DELTASOL	The deviation temperature that SOLAR turns on	10	°C
8.1	T1S_HA_H	The target outlet water temperature for space heating in holiday away mode	25	°C
8.2	T5S_HA_DHW	The target tank temperature for domestic hot water heating in holiday away mode	25	°C
12	PREHEATING FOR FLOOR-T1S	The setting temperature of outlet water during first preheating for floor	25	°C
	FLOOR DRYING UP	The function of drying up the floor	/	/
	t_FIRSTFH	Running time for first preheating of the floor	72	HOUR
	t_DRYUP	Temp-up days for floor drying up	8	DAY
	t_HIGHPEAK	Days for floor drying up	5	DAY
	t_DRYD	Temp-down days for floor drying up	5	DAY
	t_DRYPEAK	Outlet temperature of floor drying up	45	°C
	START TIME	The start time of floor drying up	Hour: the present time(not on the hour +1, on the hour +2) Minute:00	h/min
START DATE	The start date of floor drying up	The present date	d/m/y	
13.1	AUTO RESTART COOL/HEAT MODE	Enable or disable the auto restart cooling/heating mode. 0=NON,1=YES	1	/
13.2	AUTO RESTART DHW MODE	Enable or disable the auto restart DHW mode. 0=NON,1=YES	1	/
14.1	POWER INPUT LIMITATION	The type of power input limitation	0	/

Order number	Code	State	Default	Unit
15.1	M1M2	Define the function of the M1M2 switch: 0= REMOTE ON/OFF,1= TBH ON/OFF,2= AHS ON/OFF	0	/
15.2	SMART GRID	Enable or disable the SMART GRID: 0=NON,1=YES	0	/
15.3	T1T2	Control options of Port T1T2: 0=NON,1=RT/Ta_PCB	0	/
15.4	Tbt	Enable or disable the Tbt: 0=NON,1=YES	0	/
15.5	P_X PORT	Select the function of P_X PORT:0=DEFORST,1=ALARM	0	/
16.1	PER_START	Start-up percentage of multiple units	10	%
16.2	TIME_ADJUST	Adjustment time of loading and unloading units	5	min
16.3	ADDRESS RESET	Reset the address code of the unit	FF	/
17.1	HMI SET	Choose the HMI: 0=MASTER	0	/
17.2	HMI ADDRESS FOR BMS	Set the HMI address code for BMS	1	/
17.3	STOP BIT	Upper computer stop bit:1=STOP BIT1,2=STOP BIT2	1	/
18.1	t_DELAY PUMP	The time that the compressor has run before starting the pump.	2	min
18.2	t1_ANTILOCK PUMP	The pump anti-lock interval time	24	h
18.3	t2_ANTILOCK PUMP RUN	The pump anti-lock running time.	60	s
18.4	t1_ANTILOCK SV	The valve anti-lock interval time.	24	h
18.5	t2_ANTILOCK SV RUN	The valve anti-lock running time.	30	s
18.6	Ta_adj.	The corrected value of Ta inside wired controller.	-2	°C
18.7	F-PIPE LENGTH	Select the total length of the liquid pipe(F-PIPE LENGTH): 0=F-PIPE LENGTH<10m,1=F-PIPE LENGTH>=10m	0	/
18.8	PUMP_I SILENT OUTPUT	The pump_I max output limitation.	100	%

For further information and for the Modbus mapping table, see the service manual *201.55-M1.EN.CE*.

12 FINAL CHECKS AND TEST RUN

The installer must verify that the unit is operating correctly after installation.

12.1 Final checks

Before switching on the unit, read following recommendations:

- When the installation and parameter setting are completed, cover all the sheet metal of the unit well.
- The unit should be maintained by professionals.

12.2 Test run operation(manually)

TEST RUN is used to check correct operation of the valves, air purge, circulation pump operation, cooling, heating and domestic water heating.

Go to > FOR SERVICEMAN> 11.TEST RUN.
Press . The password is 234. The following page will be displayed:

11 TEST RUN	
ACTIVE THE SETTINGS AND ACTIVE THE "TEST RUN"?	
NO	YES
CONFIRM	

If YES is selected, the following pages will be displayed:

11 TEST RUN	
11.1 POINT CHECK	
11.2 AIR PURGE	
11.3 CIRCULATED PUMP RUNNING	
11.4 COOL MODE RUNNING	
11.5 HEAT MODE RUNNING	
ENTER	

11 TEST RUN	
11.6 DHW MODE RUNNING	
ENTER	

If POINT CHECK is selected, the following pages will be displayed:

11 TEST RUN		1/3
SV2	OFF	
SV3	OFF	
PUMPI	OFF	
PUMPO	OFF	
PUMPC	OFF	
ON/OFF		

11 TEST RUN		2/3
IBH	OFF	
AHS	OFF	
SV1	OFF	
PUMPD	OFF	
PUMPS	OFF	
ON/OFF		

11 TEST RUN		3/3
TBH	OFF	
ON/OFF		

Press to scroll to the components you want to check and press .

CAUTION

Before using POINT CHECK, make sure that the water system and the tank are filled with water, and air is expelled, otherwise the pump or backup heater (optional) may be broken.

If you select AIR PURGE, the following page will be displayed :

11 TEST RUN(POINT CHECK)	
AIR PURGE PUMPI OUTPUT	70%
AIR PURGE RUNNING TIME	20min
ENTER	EXIT
CONFIRM	

PUMPI will run according to the output and running time that has been set.

When CIRCULATED PUMP RUNNING is selected, the following page will be displayed:

11 TEST RUN	
TEST RUN IS ON. CIRCULATED PUMP IS ON.	
CONFIRM	

When circulation pump running is turned on, all running components will stop. 60 seconds later, the SV1 will be off, the SV2 will be on, 60 seconds later PUMPI will operate. 30s later, if the flow switch checked normal flow, PUMPI will operate for 3min, after the pump stops 60 seconds, the SV1 will close and the SV2 will be off. 60s later both PUMPI and PUMPO will operate, 2 mins later, the flow switch will check the water flow. If the flow switch closes for 15s, PUMPI and PUMPO will operate until the next command is received.

When the COOL MODE RUNNING is selected, the following page will be displayed:

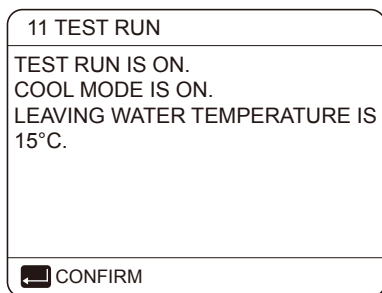

During COOL MODE test running, the default target outlet water temperature is 7°C. The unit will operate until the water temperature drops to a certain value or the next command is received.

When the HEAT MODE RUNNING is selected, the following page will be displayed:

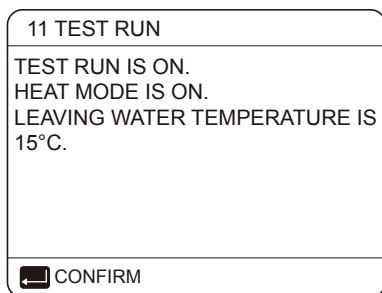

During HEAT MODE test running, the default target outlet water temperature is 35°C. The IBH (backup heater) will turn on after the compressor runs for 10 min. After the IBH runs for 3 minutes, the IBH will turn off, the heat pump will operate until the water temperature increase to a certain value or the next command is received.

When the DHW MODE RUNNING is selected, the following page will be displayed:

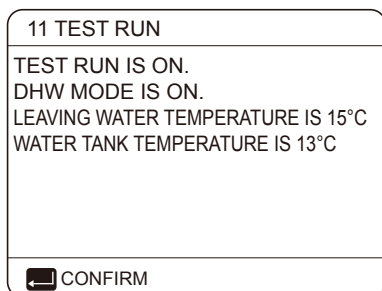

During DHW MODE test running, the default target temperature of the domestic water is 55°C. The TBH (tank boost heater) will turn on after the compressor runs for 10min. The TBH will turn off 3 minutes later, the heat pump will operate until the water temperature increase to a certain value or the next command is received.

During test run, all buttons except \leftarrow are invalid. If you want to turn off the test run, please press \leftarrow . For example, when the unit is in air purge mode, after you press \leftarrow , the following page will be displayed:

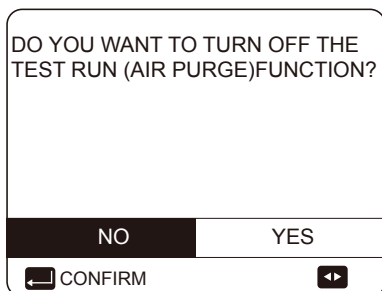

Press \leftarrow \rightarrow to scroll the cursor to YES and press \rightarrow . The test run will turn off.

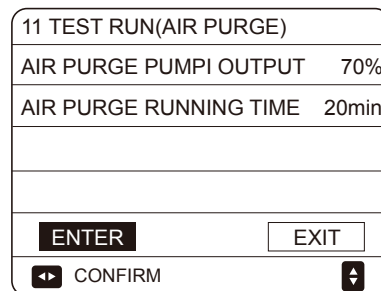

Press ∇ \blacktriangle \leftarrow \rightarrow to adjust the parameters, click "ENTER" to send the setting parameters, the following pages will be displayed:

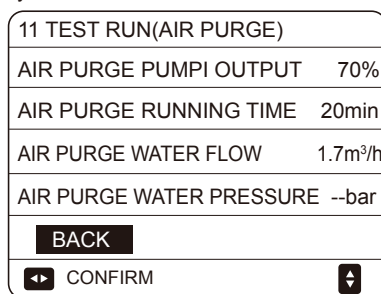

Press "BACK" to return to the AIR PURGE parameter setting screen

13 MAINTENANCE AND SERVICE

In order to ensure optimal availability of the unit, a number of checks and inspections on the unit and the field wiring have to be carried out at regular intervals.

This maintenance needs to be carried out by your local technician.

DANGER

ELECTRIC SHOCK

- Before carrying out any maintenance or repairing activity, you must switch off the power supply on the supply panel.
- Do not touch any live part for 10 minutes after the power supply is turned off.
- The crank heater of the compressor may operate even in standby.
- Please note that some sections of the electric component box are hot.
- Do not touch any conductive parts.
- Do not rinse the unit. It may cause electric shock or fire.

Do not leave the unit unattended when the service panel is removed.

The following checks must be performed at least once a year by a qualified person.

- Water pressure
 - Check the water pressure, if it is below 1 bar, fill water to the system.
- Water filter
 - Clean the water filter.
- Water pressure relief valve
 - Check for correct operation of the pressure relief valve by turning the black knob on the valve counter-clockwise:
If you do not hear a clacking sound, contact your local dealer.
 - In case the water keeps running out of the unit, close both the water inlet and outlet shut-off valves first and then contact your local dealer.
- Pressure relief valve hose
 - Check that the pressure relief valve hose is positioned appropriately to drain the water.
- Backup heater vessel insulation cover
 - Check that the backup heater insulation cover is fastened tightly around the backup heater vessel.
- Domestic hot water tank pressure relief valve (field supply)
 - Applies only to installations with a domestic hot water tank. Check for correct operation of the pressure relief valve on the domestic hot water tank.
- Domestic hot water tank booster heater
 - Applies only to installations with a domestic hot water tank. It is advisable to remove lime buildup on the booster heater to extend its life span, especially in regions with hard water. To do so, drain the domestic hot water tank, remove the booster heater from the domestic hot water tank and immerse in a bucket (or similar) with lime-removing product for 24 hours.
- Unit switch box
 - Carry out a thorough visual inspection of the switch box and look for obvious defects such as loose connections or defective wiring.
 - Check for correct operation of contactors with an ohm meter. All contacts of these contactors must be in the open position.
- Use of glycol (Refer to 9.3.4 "Water circuit anti-freeze protection").
Document the glycol concentration and the pH-value in the system at least once a year.
 - A PH-value below 8.0 indicates that a significant portion of the inhibitor has been depleted and that more inhibitor needs to be added.
 - When the PH-value is below 7.0 then oxidation of the glycol has occurred. The system should be drained and flushed thoroughly before severe damage occurs.
- Make sure that the disposal of the glycol solution is done in accordance with relevant local laws and regulations.

14 TROUBLESHOOTING

This section provides useful information for diagnosing and correcting certain troubles which may occur in the unit.

This troubleshooting and related corrective actions may only be carried out by your local technician.

14.1 General guidelines

Before starting the troubleshooting procedure, carry out a thorough visual inspection of the unit and look for obvious defects such as loose connections or defective wiring.

WARNING

When carrying out an inspection on the switch box of the unit, always make sure that the main switch of the unit is switched off.

When a safety device is activated, stop the unit and find out why the safety device was activated before resetting it. Under no circumstances can safety devices be bridged or changed to a valve other than the factory setting. If the cause of the problem cannot be found, call your local dealer.

If the pressure relief valve is not working correctly and is to be replaced, always reconnect the flexible hose attached to the pressure relief valve to avoid water dripping out of the unit.

NOTE

For problems related to the optional solar kit for domestic water heating, refer to the troubleshooting in the Installation and owner's manual for that kit.

14.2 General symptoms

Symptom 1: The unit is turned on but the unit is not heating or cooling as expected

POSSIBLE CAUSES	CORRECTIVE ACTION
The temperature setting is not correct.	Check the parameters (T4HMAX, T4HMIN in heating mode; T4CMAX, T4CMIN in cooling mode; T4DHWMAX, T4DHWMIN in DHW mode). For the parameter setting range, please refer to 11.1 Setting parameters.
The water flow is too low.	<ul style="list-style-type: none"> • Check that all shut off valves of the water circuit are in the right position. • Check if the water filter is plugged. • Make sure there is no air in the water system. • Check the water pressure. The water pressure must be ≥ 1.5 bar. • Make sure that the expansion vessel is not broken.
The water volume in the installation is too low.	Make sure that the water volume in the installation is above the minimum required value. Please refer to 9.3.2 Water volume and sizing expansion vessels.

Symptom 2: The unit is turned on but the compressor is not starting

POSSIBLE CAUSES	CORRECTIVE ACTION
The unit maybe operate out of its operation range (the water temperature is too low).	<p>In case of low water temperature, the system utilizes the backup heater to reach the minimum water temperature first (12°C).</p> <ul style="list-style-type: none"> • Check that the backup heater power supply is correct. • Check that the backup heater thermal fuse is closed. • Check that the backup heater thermal protector is not activated. • Check that the backup heater contactors are not broken.

Symptom 3: Pump is making noise (cavitation)

POSSIBLE CAUSES	CORRECTIVE ACTION
There is air in the system.	Purge air.
Water pressure at pump inlet is too low.	<ul style="list-style-type: none"> • Check the water pressure. The water pressure must be ≥ 1.5 bar. • Check that the expansion vessel is not broken. • Check that the setting of the pre- pressure of the expansion vessel is correct.

Symptom 4: The water pressure relief valve opens

POSSIBLE CAUSES	CORRECTIVE ACTION
The expansion vessel is broken.	Replace the expansion vessel.
The filling water pressure in the installation is higher than 0.3MPa.	Make sure that the filling water pressure in the installation is 0.10~0.20MPa.

Symptom 5: The water pressure relief valve leaks

POSSIBLE CAUSES	CORRECTIVE ACTION
Dirt is blocking the water pressure relief valve outlet.	<ul style="list-style-type: none"> • Check for correct operation of the pressure relief valve by turning the black knob on the valve counterclockwise: • If you do not hear a clacking sound, contact your local dealer. • In case the water keeps running out of the unit, close both the water inlet and outlet shut-off valves first and then contact your local dealer.

Symptom 6: Space heating capacity shortage at low outdoor temperatures

POSSIBLE CAUSES	CORRECTIVE ACTION
Backup heater operation is not activated.	<ul style="list-style-type: none"> • Check if that the "OTHER HEATING SOURCE/ IBH FUNCTION" is enabled. • Check whether or not the thermal protector of the backup heater has been activated. • Check if booster heater is running. The backup heater and booster heater can't operate simultaneously.
Too much heat pump capacity is used for heating domestic hot water (applies only to installations with a domestic hot water tank).	<p>Check that the "t_DHWHP_MAX" and "t_DHWHP_RESTRICT" are configured appropriately:</p> <ul style="list-style-type: none"> • Make sure that the "DHW PRIORITY" in the user interface is disabled. • Enable the "T4_TBH_ON" in the user interface/FOR SERVICEMAN to activate the booster heater for domestic water heating.

Symptom 7: Heat mode can't change to DHW mode immediately

POSSIBLE CAUSES	CORRECTIVE ACTION
Volume of tank is too low and the location of water temperature probe not high enough	<ul style="list-style-type: none"> • Set "dT1S5" to maximum valve, and set "t_DHWHP_RESTRICT" to minimum valve. • Set dT1SH to 2°C. • Enable TBH, and TBH should be controlled by the outdoor unit. • If AHS is available, turn on first, if requirement for turn heat pump on is fulfilled, the heat pump will turn on. • If both TBH and AHS are not available, try to change the position of T5 probe(refer to 2 "General introduction").

Symptom 8: DHW mode can't change to Heat mode immediately

POSSIBLE CAUSES	CORRECTIVE ACTION
Heat exchanger for space heating not big enough	<ul style="list-style-type: none"> • Set "t_DHWHP_MAX" to minimum valve, the suggested valve is 60min. • If circulating pump out of unit is not controlled by the unit, try to connect it to the unit. • Add 3-way valve at the inlet of fan coil to ensure enough water flow.
Space heating load is small	Normal , no need for heating
Disinfect function is enabled but without TBH	<ul style="list-style-type: none"> • Disable disinfect function • Add TBH or AHS for DHW mode
Manual turn on the FAST WATER function, after the hot water meets the requirements, the heat pump fails to switch to the air-conditioning mode in time when the air conditioner is in demand	Manual turn off the FAST WATER function
When the ambient temperature is low, there is not enough hot water and the AHS does not operate or is operating late	<ul style="list-style-type: none"> • Set "T4DHWMIN", the suggested valve is $\geq -5^{\circ}\text{C}$ • Set "T4_TBH_ON", the suggested valve is $\geq 5^{\circ}\text{C}$
DHW mode priority	If there is AHS or IBH connect to the unit, when the outdoor unit failed, the hydraulic module board must run DHW mode till the water temperature reach the setting temperature before change to heating mode.

Symptom 9: DHW mode heat pump stop work but setpoint not reached, space heating require heat but unit stay in DHW mode

POSSIBLE CAUSES	CORRECTIVE ACTION
Surface of coil in the tank not large enough	The same solution for Symptom 7
TBH or AHS not available	<ul style="list-style-type: none"> • Check whether IBH(AHS or TBH) is set valid in "FOR SERVICEMAN" or whether IBH is set valid by DIP switch on the main control board of hydraulic module. • Check whether IBH(AHS or TBH) is damaged.

14.3 Error codes

A series of error codes and corresponding meaning can be found in the table below.

Reset the unit by turning the unit ON or OFF.

If Resetting the unit is invalid, contact your local dealer.

UPPER UNIT DISPLAY No.	ERROR CODE	MALFUNCTION OR PROTECTION
1	<i>E0</i>	Water flow malfunction(after 3 times E8)
3	<i>E2</i>	Communication malfunction between controller and hydraulic module
4	<i>E3</i>	Total outlet water temp.sensor(T1) malfunction
5	<i>E4</i>	Water tank temp.sensor (T5) malfunction
8	<i>E7</i>	Buffer tank upper temp.sensor(Tbt) malfunction
9	<i>E8</i>	Water flow malfunction
12	<i>E6</i>	Solar temp.sensor(Tsolar) malfunction
14	<i>E4</i>	Inlet water temp.sensor (Tw_in) malfunction
15	<i>EE</i>	Hydraulic module EEprom malfunction
39	<i>H0</i>	Communication malfunction between main control board and hydraulic module board
41	<i>H2</i>	Liquid refrigerant temp.sensor(T2) malfunction
42	<i>H3</i>	Gas refrigerant temp.sensor(T2B) malfunction
44	<i>H5</i>	Room temp.sensor(Ta) malfunction
48	<i>H9</i>	Outlet water for zone 2 temp.sensor (Tw2) malfunction
49	<i>HA</i>	Outlet water temp.sensor (Tw_out) malfunction
50	<i>Hb</i>	Three times PP protection and Tw_out below 7 °C
52	<i>Hd</i>	Communication malfunction between master unit and subordinate unit
25	<i>P5</i>	Tw_out-Tw_in value too big protection
31	<i>Pb</i>	Anti-freeze mode

UPPER UNIT DISPLAY No.	ERROR CODE	MALFUNCTION OR PROTECTION
38	<i>PP</i>	Tw_out-Tw_in abnormal protection
2	<i>E1</i>	Phase loss or neutral wire and live wire are connected reversely
6	<i>E5</i>	Air side heat exchanger temperature sensor (T3)malfunction
7	<i>E6</i>	The ambient temperature sensor (T4)malfunction
10	<i>E9</i>	Suction temperature sensor(Th) malfunction
11	<i>EA</i>	Discharge temperature sensor(Tp) malfunction
40	<i>H1</i>	Communication malfunction between main control board and inverter board
43	<i>H4</i>	Three times L0 protection
45	<i>H6</i>	The DC fan malfunction
46	<i>H7</i>	Voltage protection
47	<i>H8</i>	Pressure sensor malfunction
54	<i>HF</i>	Inverter module board EE prom malfunction
55	<i>HH</i>	10 times H6 in 2 hours
57	<i>HP</i>	Low pressure protection in cooling mode
20	<i>P0</i>	Low pressure switch protection
21	<i>P1</i>	High pressure switch protection
23	<i>P3</i>	Compressor overcurrent protection.
24	<i>P4</i>	Comp discharge temp. too high protection

UPPER UNIT DISPLAY No.	ERROR CODE	MALFUNCTION OR PROTECTION
33	<i>Pd</i>	High temperature protection of air side heat exchanger temperature(T3).
65	<i>L7</i>	High temperature protection of inverter module
116	<i>F1</i>	DC bus low voltage protection
134	<i>LO</i>	Inverter or compressor protection
135	<i>L1</i>	DC bus low voltage protection.
136	<i>L2</i>	DC bus high voltage protection
137	<i>L3</i>	Current sampling error of PFC circuit
138	<i>L4</i>	Rotating stall protection
139	<i>L5</i>	Zero speed protection
141	<i>L7</i>	Phase loss protection of compressor
121	<i>F6</i>	EXV1 fault
106	<i>bA</i>	T4 sensor out of operation range.

 **CAUTION**

In winter, if the unit has E0 and Hb malfunction and the unit is not repaired in time, the water pump and pipeline system may be damaged by freezing, so E0 and Hb malfunction must be repaired in time.

15 TECHNICAL SPECIFICATIONS

15.1 General

Model	1-phase	1-phase	3-phase
	5/7/9 kW	12/14/16 kW	12/14/16 kW
Nominal capacity	Refer to the Technical Data		
Dimensions HxWxD	865×1040×410mm	865×1040×410mm	865×1040×410mm
Packing Dimensions HxWxD	970×1190×560mm	970×1190×560mm	970×1190×560mm
Weight			
Net weight	87kg	106kg	120kg
Gross weight	103kg	122kg	136kg
Connections			
Water inlet/outlet	G1"BSP	G5/4"BSP	G5/4"BSP
Water drain	Hose nipple		
Expansion vessel			
Volume	5L		
Maximum working pressure (MWP)	8 bar		
Pump			
Type	Water cooled	Water cooled	Water cooled
No. of speed	Variable speed	Variable speed	Variable speed
Pressure relief valve water circuit	3 bar		
Operation range - water side			
Heating	+15~+65°C		
Cooling	+5~+25°C		
Domestic hot water by heat pump	+15~+60°C		
Operation range - air side			
Heating	-25~+35°C		
Cooling	-5~+43°C		
Domestic hot water by heat pump	-25~+43°C		

15.2 Electrical specifications

Model		1-phase 5/7/9/12/14/16kW	3-phase 12/14/16kW
Standard unit	Power Supply	220-240V~ 50Hz	380-415V 3N~ 50Hz
	Nominal Running Current	See "9.6.4 Safety device requirement"	

16 INFORMATION SERVICING

1) Checks to the area

Prior to beginning work on systems containing flammable refrigerants, safety checks are necessary to ensure that the risk of ignition is minimized. For repair to the refrigerating system, the following precautions shall be complied with prior to conducting work on the system.

2) Work procedure

Works shall be undertaken under a controlled procedure so as to minimize the risk of a flammable gas or vapor being present while the work is being performed.

3) General work area

All maintenance staff and others working in the local area shall be instructed on the nature of work being carried out. Work in confined spaces shall be avoided. The area around the work space shall be sectioned off. Ensure that the conditions within the area have been made safe by the control of flammable material.

4) Checking for presence of refrigerant

The area shall be checked with an appropriate refrigerant detector prior to and during work, to ensure the technician is aware of potentially flammable atmospheres. Ensure that the leak detection equipment being used is suitable for use with flammable refrigerants, i.e. no sparking, adequately sealed or intrinsically safe.

5) Presence of fire extinguisher

If any hot work is to be conducted on the refrigeration equipment or any associated parts, appropriate fire extinguishing equipment shall be available to hand. Have a dry power or CO₂ fire extinguisher adjacent to the charging area.

6) No ignition sources

No person carrying out work in relation to a refrigeration system which involves exposing any pipe work that contains or has contained flammable refrigerant shall use any sources of ignition in such a manner that it may lead to the risk of fire or explosion. All possible ignition sources, including cigarette smoking, should be kept sufficiently far away from the site of installation, repairing, removing and disposal, during which flammable refrigerant can possibly be released to the surrounding space. Prior to work taking place, the area around the equipment is to be surveyed to make sure that there are no flammable hazards or ignition risks. NO SMOKING signs shall be displayed.

7) Ventilated area

Ensure that the area is in the open or that it is adequately ventilated before breaking into the system or conducting any hot work. A degree of ventilation shall continue during the period that the work is carried out. The ventilation should safely disperse any released refrigerant and preferably expel it externally into the atmosphere.

8) Checks to the refrigeration equipment

Where electrical components are being changed, they shall be fit for the purpose and to the correct specification. At all times the manufacturer's maintenance and service guidelines shall be followed. If in doubt consult the manufacturer's technical department for assistance. The following checks shall be applied to installations using flammable refrigerants.

The charge size is in accordance with the room size within which the refrigerant containing parts are installed.

The ventilation machinery and outlets are operating adequately and are not obstructed.

If an indirect refrigerating circuit is being used, the secondary circuits shall be checked for the presence of refrigerant; marking to the equipment continues to be visible and legible.

Marking and signs that are illegible shall be corrected.

Refrigeration pipe or components are installed in a position where they are unlikely to be exposed to any substance which may corrode refrigerant containing components, unless the components are constructed of materials which are inherently resistant to being corroded or are suitably protected against being so corroded.

9) Checks to electrical devices

Repair and maintenance to electrical components shall include initial safety checks and component inspection procedures. If a fault exists that could compromise safety, no electrical supply shall be connected to the circuit until it is satisfactorily dealt with. If the fault cannot be corrected immediately but it is necessary to continue operation, an adequate temporary solution shall be used. This shall be reported to the owner of the equipment so all parties are advised.

Initial safety checks shall include:

That capacitors are discharged: this shall be done in a safe manner to avoid the possibility of sparking.

That there are no live electrical components or exposed wiring while charging, recovering or purging the system.

That there is continuity of earth bonding.

10) Repairs to sealed components

a) During repairs to sealed components, all electrical supplies shall be disconnected from the equipment being worked upon prior to the removal of any sealed covers, etc. If it is absolutely necessary to have an electrical supply to equipment during servicing, then a permanently operating form of leak detection shall be located at the most critical point to warn of a potentially hazardous situation.

b) Particular attention shall be paid to the following to ensure that by working on electrical components, the casing is not altered in such a way that the level of protection is affected. This shall include damage to cables, excessive number of connections, terminals not made to original specification, damage to seals, incorrect fitting of glands, etc.

Ensure that apparatus is mounted securely.

Ensure that seals or sealing materials have not degraded such that they no longer serve the purpose of preventing the ingress of flammable atmospheres. Replacement parts shall be in accordance with the manufacturer's specifications.

The use of silicon sealant may inhibit the effectiveness of some types of leak detection equipment. Intrinsically safe components do not have to be isolated prior to working on them.

11) Repair to intrinsically safe components

Do not apply any permanent inductive or capacitance loads to the circuit without ensuring that this will not exceed the permissible voltage and current permitted for the equipment in use. Intrinsically safe components are the only types that can be worked on while live in the presence of a flammable atmosphere. The test apparatus shall be at the correct rating. Replace components only with parts specified by the manufacturer. Other parts may result in the ignition of refrigerant in the atmosphere from a leak.

12) Cabling

Check that cabling will not be subject to wear, corrosion, excessive pressure, vibration, sharp edges or any other adverse environmental effects. The check shall also take into account the effects of aging or continual vibration from sources such as compressors or fans.

13) Detection of flammable refrigerants

Under no circumstances shall potential sources of ignition be used in the searching for, or detection of, refrigerant leaks. A halide torch (or any other detector using a naked flame) shall not be used.

14) Leak detection methods

The following leak detection methods are deemed acceptable for systems containing flammable refrigerants. Electronic leak detectors shall be used to detect flammable refrigerants, but the sensitivity may not be adequate, or may need re-calibration. (Detection equipment shall be calibrated in a refrigerant-free area.) Ensure that the detector is not a potential source of ignition and is suitable for the refrigerant. Leak detection equipment shall be set at a percentage of the LFL of the refrigerant and shall be calibrated to the refrigerant employed and the appropriate percentage of gas (25% maximum) is confirmed. Leak detection fluids are suitable for use with most refrigerants but the use of detergents containing chlorine shall be avoided as the chlorine may react with the refrigerant and corrode the copper pipe-work. If a leak is suspected, all naked flames shall be removed or extinguished. If a leakage of refrigerant is found which requires brazing, all of the refrigerant shall be recovered from the system, or isolated (by means of shut off valves) in a part of the system remote from the leak. Oxygen free nitrogen (OFN) shall then be purged through the system both before and during the brazing process.

15) Removal and evacuation

When breaking into the refrigerant circuit to make repairs or for any other purpose conventional procedures shall be used. However, it is important that best practice is followed since flammability is a consideration. The following procedure shall be adhered to:

Remove refrigerant;

Purge the circuit with inert gas;

Evacuate;

Purge again with inert gas;

Open the circuit by cutting or brazing.

The refrigerant charge shall be recovered into the correct recovery cylinders. The system shall be flushed with OFN to render the unit safe. This process may need to be repeated several times.

Compressed air or oxygen shall not be used for this task.

Flushing shall be achieved by breaking the vacuum in the system with OFN and continuing to fill until the working pressure is achieved, then venting to atmosphere, and finally pulling down to a vacuum. This process shall be repeated until no refrigerant is in the system.

When the final OFN charge is used, the system shall be vented down to atmospheric pressure to enable work to take place. This operation is absolutely vital if brazing operations on the pipe-work are to take place.

Ensure that the outlet for the vacuum pump is not close to any ignition sources and there is ventilation available.

16) Charging procedures

In addition to conventional charging procedures, the following requirements shall be followed:

Ensure that contamination of different refrigerants does not occur when using charging equipment. Hoses or lines shall be as short as possible to minimize the amount of refrigerant contained in them.

Cylinders shall be kept upright.

Ensure that the refrigeration system is earthed prior to charging the system with refrigerant.

Label the system when charging is complete (if not already labelled).

Extreme care shall be taken not to overfill the refrigeration system.

Prior to recharging the system it shall be pressure tested with OFN. The system shall be leak tested on completion of charging but prior to commissioning. A follow up leak test shall be carried out prior to leaving the site.

17) Decommissioning

Before carrying out this procedure, it is essential that the technician is completely familiar with the equipment and all its detail. It is recommended good practice that all refrigerants are recovered safely. Prior to the task being carried out, an oil and refrigerant sample shall be taken in case analysis is required prior to re-use of reclaimed refrigerant.

It is essential that electrical power is available before the task is commenced.

- a) Become familiar with the equipment and its operation.
- b) Isolate system electrically
- c) Before attempting the procedure ensure that:

d) Mechanical handling equipment is available, if required, for handling refrigerant cylinders.

All personal protective equipment is available and being used correctly.

The recovery process is supervised at all times by a competent person.

Recovery equipment and cylinders conform to the appropriate standards.

e) Pump down refrigerant system, if possible.

f) If a vacuum is not possible, make a manifold so that refrigerant can be removed from various parts of the system.

g) Make sure that cylinder is situated on the scales before recovery takes place.

h) Start the recovery machine and operate in accordance with manufacturer instructions.

i) Do not overfill cylinders. (No more than 80% volume liquid charge).

j) Do not exceed the maximum working pressure of the cylinder, even temporarily.

k) When the cylinders have been filled correctly and the process completed, make sure that the cylinders and the equipment are removed from site promptly and all isolation valves on the equipment are closed off.

l) Recovered refrigerant shall not be charged into another refrigeration system unless it has been cleaned and checked.

18) Labeling

Equipment shall be labeled stating that it has been de-commissioned and emptied of refrigerant. The label shall be dated and signed. Ensure that there are labels on the equipment stating the equipment contains flammable refrigerant.

19) Recovery

When removing refrigerant from a system, either for service or decommissioning, it is recommended good practice that all refrigerants are removed safely.

When transferring refrigerant into cylinders, ensure that only appropriate refrigerant recovery cylinders are employed.

Ensure that the correct numbers of cylinders for holding the total system charge are available. All cylinders to be used are designated for the recovered refrigerant and labeled for that refrigerant (i.e special cylinders for the recovery of refrigerant).

Cylinders shall be complete with pressure relief valve and associated shut-off valves in good working order.

Empty recovery cylinders are evacuated and, if possible, cooled before recovery occurs.

The recovery equipment shall be in good working order with a set of instructions concerning the equipment that is at hand and shall be suitable for the recovery of flammable refrigerants. In addition, a set of calibrated weighing scales shall be available and in good working order.

Hoses shall be complete with leak-free disconnect couplings and in good condition. Before using the recovery machine, check that it is in satisfactory working order, has been properly maintained and that any associated electrical components are sealed to prevent ignition in the event of a refrigerant release. Consult manufacturer if in doubt.

The recovered refrigerant shall be returned to the refrigerant supplier in the correct recovery cylinder, and the relevant Waste Transfer Note arranged. Do not mix refrigerants in recovery units and especially not in cylinders.

If compressors or compressor oils are to be removed, ensure that they have been evacuated to an acceptable level to make certain that flammable refrigerant does not remain within the lubricant. The evacuation process shall be carried out prior to returning the compressor to the suppliers. Only electric heating to the compressor body shall be employed to accelerate this process. When oil is drained from a system, it shall be carried out safely.

20) Transportation, marking and storage for units

Transport equipment containing flammable refrigerants in compliance with the transport regulations.

Mark equipment using signs in compliance with local regulations.

Dispose of equipment using flammable refrigerants in compliance with national regulations.

Storage of equipment/appliances:

The storage of equipment should be in accordance with the manufacturer's instructions.

Storage of packed (unsold) equipment:

Storage package protection should be constructed such that mechanical damage to the equipment inside the package will not cause a leak of the refrigerant charge.

The maximum number of pieces of equipment permitted to be stored together will be determined by local regulations.

ANNEX A: Refrigerant cycle

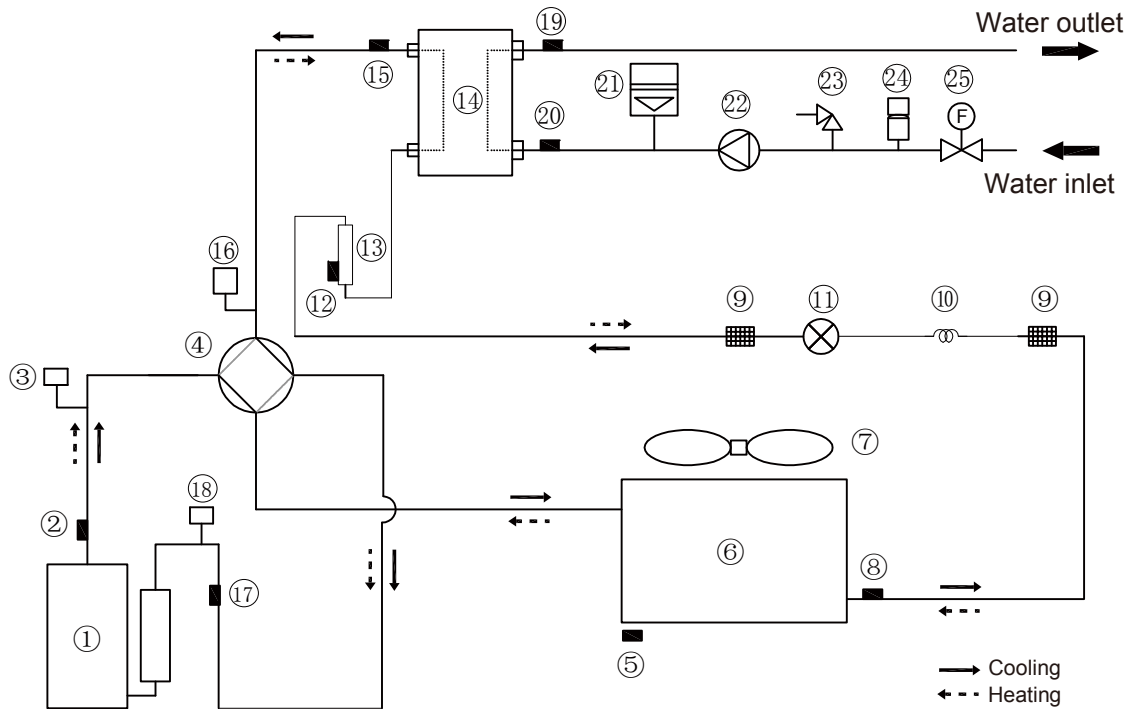

Item	Description	Item	Description
1	Compressor	14	Plate heat exchanger
2	Discharge temperature sensor	15	Gas refrigerant temperature sensor
3	High pressure switch	16	Pressure sensor
4	4-way valve	17	Suction temperature sensor
5	Ambient temperature sensor	18	Low pressure switch
6	Air side heat exchanger	19	Outlet water temperature sensor
7	DC_FAN	20	Inlet water temperature sensor
8	Air side heat exchanger temperature sensor	21	Expansion vessel
9	Strainer	22	Water pump
10	Capillary	23	Pressure relief valve
11	Electronic expansion valve	24	Automatic air purge valve
12	Liquid refrigerant temperature sensor	25	Water flow switch
13	Accumulator cylinder		

ANNEX B: To install the E-heating tape at the drainage outlet (by client)

Connect the heating tape wire at the drainage outlet to the wire joint XT3.

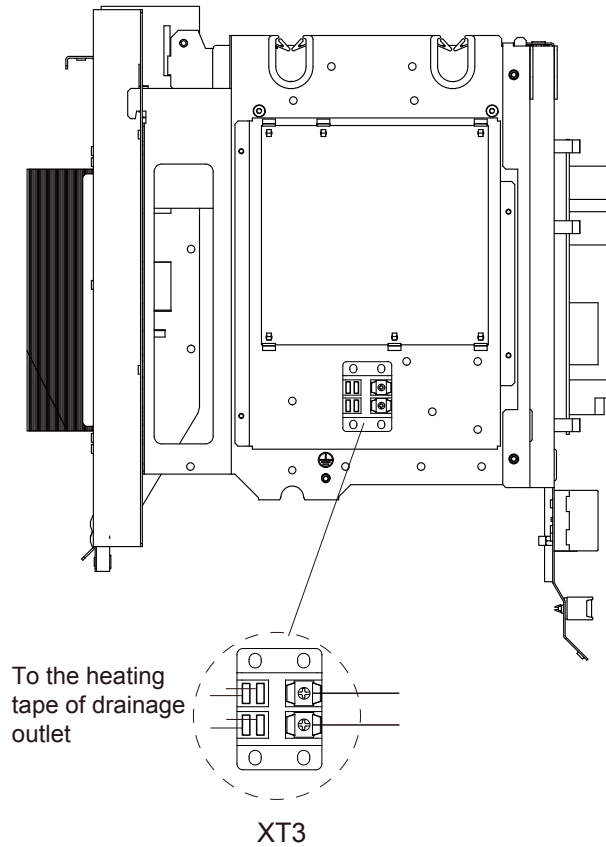

The picture is for reference only, please refer to the actual product.

The power of the E-heating tape shall not exceed 40W/200mA, supply voltage 230VAC.

SAFETY DATA SHEET

according to Regulation (EC) No. 1907/2006

HFC-32, R-32



Version 1, Revision Date 05.07.2022

SECTION 1: Identification of the substance/mixture and of the company/undertaking

1.1. Product identifier

Product name : Refrigerating Machines containing R32
Product Type : R32
Chemical name : Difluoromethane
EC-No. : 200-839-4
CAS-No. : 75-10-5

1.2. Relevant identified uses of the substance or mixture and uses advised against

1.2.1. Relevant identified uses

Main use category : Refrigerant

1.2.2. Uses advised against

Restrictions on use : No information available

1.3. Details of the supplier of the safety data sheet

Supplier : Johnson Controls Industries.
Address : ZI, BP 70309, 14 rue de Bel Air, CARQUEFOU -FRANCE
Zip Code : 44470
Tel : (+33) 240 306 200
E-mail : ehs.france.questions@jci.com

1.4. Emergency telephone number

Transport : +33 (0)9 75 18 14 07 (CHEMTREC)
Anti poison : +33 (0)1 45 42 59 59 (I.N.R.S)

SECTION 2: Hazards identification

2.1. Classification of the substance or mixture

Classification according to Regulation (EC) No. 1272/2008 [CLP]
Flammable gases, Category 1 : H220
Gases under pressure : Liquefied gas : H280
Full text of H statements : see section 16

Adverse physicochemical, human health and environmental effects
Contains gas under pressure; may explode if heated. Extremely flammable gas

2.2. Label elements

Labelling according to Regulation (EC) No. 1272/2008 [CLP]
Hazard pictograms (CLP) :



GHS02

Signal word (CLP) : Danger
Hazard statements (CLP) : H220 - Extremely flammable gas.
H280 - Contains gas under pressure; may explode if heated.
Precautionary statements (CLP) : P210 - Keep away from heat, hot surfaces, sparks, open flames and other ignition sources. No smoking.
P377 - Leaking gas fire: Do not extinguish, unless leak can be stopped safely.
P381 - In case of leakage, eliminate all ignition sources.
P403 - Store in a well-ventilated place.
P410+P403 - Protect from sunlight. Store in a well-ventilated place.

2.3. Other hazards

No additional information available

SAFETY DATA SHEET

according to Regulation (EC) No. 1907/2006

HFC-32, R-32



Version 1, Revision Date 05.07.2022

SECTION 3: Composition/information on ingredients

3.1. Substances

Name : Difluoromethane

Name	Product identifier	%	Classification according to Regulation (EC) No. 1272/2008 [CLP]
Difluoromethane	(CAS-No.) 75-10-5 (EC-No.) 200-839-4	>= 99.5	Flam. Gas 1, H220 Press. Gas (Liq.) H280

Full text of H-statements: see section 16

3.2. Mixtures

Not applicable

SECTION 4: First aid measures

4.1. Description of first aid measures

- First-aid measures general : If you feel unwell, seek medical advice (show directions for use or safety data sheet if possible).
- First-aid measures after inhalation : Remove person to fresh air and keep comfortable for breathing;
Give oxygen or artificial respiration if necessary;
If you feel unwell, seek medical advice
- First-aid measures after skin contact : Wash skin with plenty of water and take off contaminated clothing;
Take off immediately all contaminated clothing. Call a physician immediately.
If skin irritation or rash occurs: Get medical advice/attention;
Wash contaminated clothing before reuse
- First-aid measures after eye contact : Rinse cautiously with water for several minutes while holding the eyelids wide open;
Remove contact lenses, if present and easy to do. Continue rinsing
If eye irritation persists: Get medical advice/attention
- First-aid measures after ingestion : Wash out mouth with water. Remove victim to fresh air and keep at rest in a position comfortable for breathing.
Do not induce vomiting unless directed to do so by medical personnel.
Get medical attention if symptoms occur.

4.2. Most important symptoms and effects, both acute and delayed

None known

4.3. Indication of any immediate medical attention and special treatment needed

Treat symptomatically.

SECTION 5: Firefighting measures

5.1. Extinguishing media

- Suitable extinguishing media : Use extinguishing measures that are appropriate to local circumstances and the surrounding environment.
- Unsuitable extinguishing media : No information available.

5.2. Special hazards arising from the substance or mixture

- Fire hazard : Extremely flammable gas.
- Hazardous decomposition products in case of fire : Thermal decomposition can lead to release of irritating or toxic gases/vapors: carbon oxides.

5.3. Advice for firefighters

- Precautionary measures fire : Eliminate every possible source of ignition. Keep container tightly closed and away from heat, sparks and flame.
- Firefighting instructions : Eliminate all ignition sources if safe to do so. Leaking gas fire: Do not extinguish, unless leak can be stopped safely. Ensure adequate ventilation, especially in confined areas. Evacuate personnel to a safe area. Avoid contact with skin, eyes and inhalation of vapors. Move containers from fire area if it can be done without personal risk. Cool tanks/drums with water spray/remove them into safety. Stay upwind.
- Protection during firefighting : Wear self-contained breathing apparatus and chemical-protective clothing. Prevent fire extinguishing water from contaminating surface water or the ground water system.

SECTION 6: Accidental release measures

6.1. Personal precautions, protective equipment and emergency procedures

6.1.1. For non-emergency personnel

Emergency procedures : No action shall be taken involving any personal risk or without suitable training. Evacuate surrounding areas. Keep unnecessary and unprotected personnel from entering. Do not touch or walk through spilled material. Put on appropriate personal protective equipment.

6.1.2. For emergency responders

Protective equipment : Do not attempt to take action without suitable protective equipment. For further information refer to section 8: "Exposure controls/personal protection".

Emergency procedures : Refer to SECTION 8 for personal protective equipment. Prevention of skin and eye contact. Ensure adequate ventilation. Remove all sources of ignition.

6.2. Environmental precautions

Prevent further leakage or spillage if safe to do so

Prevent entry into waterways, sewers, basements or confined areas

Local authorities should be advised if significant spillages cannot be contained

See Section 12 for additional Ecological Information

6.3. Methods and material for containment and cleaning up

Methods for cleaning up : Notify authorities if product enters sewers or public waters. Mechanically recover the product

Other information : Dispose of materials or solid residues at an authorized site.

6.4. Reference to other sections

See SECTION 7 for information on safe handling.

See SECTION 8 for information on personal protection equipment.

See SECTION 13 for information on disposal.

SECTION 7: Handling and storage

7.1. Precautions for safe handling

Precautions for safe handling : Handle in accordance with good industrial hygiene and safety practice. Ensure adequate ventilation, especially in confined areas. Avoid contact with skin, eyes or clothing. Take precautionary measures against static discharges. Wash thoroughly after handling. Use personal protection recommended in Section 8

Hygiene measures : Wash contaminated clothing before reuse. Contaminated work clothing should not be allowed out of the workplace. Do not eat, drink or smoke when using this product. Always wash hands after handling the product.

7.2. Conditions for safe storage, including any incompatibilities

Storage conditions : Keep container tightly closed in a dry and well-ventilated place. Keep locked up and out of reach of children. Keep away from food, drink and animal feeding stuffs. Protect from sunlight. Keep cool.

7.3. Specific end use (s)

No additional information available

SECTION 8: Exposure controls/personal protection

8.1. Control parameters

Difluoromethane (75-10-5)

Czech Republic - Occupational Exposure Limits

Expoziční limity (PEL) (mg/m³) 2000 mg/m³

8.2. Exposure controls

Appropriate engineering controls:

Ensure good ventilation of the work station. Remove all sources of ignition. Emergency eye wash fountains and safety showers should be available in the immediate vicinity of any potential exposure.

Hand protection:

Protective gloves

SAFETY DATA SHEET

according to Regulation (EC) No. 1907/2006

HFC-32, R-32



Version 1, Revision Date 05.07.2022

Eye protection: ear safety glasses with side shields (or goggles)

Skin and body protection:

Wear protective gloves/clothing to prevent contact.

Respiratory protection:

In case of insufficient ventilation, wear suitable respiratory equipment

Environmental exposure controls:

Do not allow into any sewer, on the ground or into any body of water

SECTION 9: Physical and chemical properties

9.1. Information on basic physical and chemical properties

Physical state	: Gas
Colour	: Colourless.
Odour	: Odourless
Odour threshold	: No data available
pH	: No data available
Relative evaporation rate (butylacetate=1)	: No data available
Melting point	: ≈ -136 °C
Freezing point	: ≈ -136 °C
Boiling point	: -51.7 °C
Flash point	: No data available
Auto-ignition temperature	: No data available
Decomposition temperature	: No data available
Flammability (solid, gas)	: No data available
Vapour pressure	: 1701 kPa
Relative vapour density at 20 °C	: 0.0021
Relative density	: No data available
Density	: 0.0021 g/cm ³
Solubility	: Water: 1680 mg/l
Log Pow	: No data available
Viscosity, kinematic	: No data available
Viscosity, dynamic	: No data available
Explosive properties	: No data available
Oxidising properties	: No data available
Explosive limits	: No data available

9.2. Other information

No additional information available

SECTION 10: Stability and reactivity

10.1. Reactivity

The product is non-reactive under normal conditions of use, storage and transport.

10.2. Chemical stability

Stable under normal conditions.

10.3. Possibility of hazardous reactions

No dangerous reactions known under normal conditions of use.

10.4. Conditions to avoid

Keep away from heat, hot surfaces, sparks, open flames and other ignition sources.

10.5. Incompatible materials

No information available

10.6. Hazardous decomposition products

Thermal decomposition can lead to release of irritating and toxic gases and vapors

SAFETY DATA SHEET

according to Regulation (EC) No. 1907/2006

HFC-32, R-32



Version 1, Revision Date 05.07.2022

SECTION 11: Toxicological information

11.1. Information on toxicological effects

Acute toxicity (oral)	: Not classified
Acute toxicity (dermal)	: Not classified
Acute toxicity (inhalation)	: Not classified
Skin corrosion/irritation	: Not classified
Serious eye damage/irritation	: Not classified
Respiratory or skin sensitisation	: Not classified
Germ cell mutagenicity	: Not classified
Carcinogenicity	: Not classified
Reproductive toxicity	: Not classified
STOT-single exposure	: Not classified
STOT-repeated exposure	: Not classified
Aspiration hazard	: Not classified

SECTION 12: Ecological information

12.1. Toxicity

Ecology - general	: The product is not considered harmful to aquatic organisms nor to cause long-term adverse effects in the environment.
Acute aquatic toxicity	: Not classified
Chronic aquatic toxicity	: Not classified

12.2. Persistence and degradability

No additional information available

12.3. Bioaccumulative potential

Propane (74-98-6)

Log Pow 2.3

12.4. Mobility in soil

No additional information available

12.5. Results of PBT and vPvB assessment

PBT/vPvB assessment information is not available as chemical safety assessment not conducted.

12.6. Other adverse effects

No additional information available

SECTION 13: Disposal considerations

13.1. Waste treatment methods

Waste treatment methods	: Disposal should be in accordance with applicable regional, national and local laws and regulations
Product/Packaging disposal recommendations	: Empty containers should be taken for local recycling, recovery or waste disposal.

SECTION 14: Transport information

In accordance with ADR / RID / IMDG / IATA / ADN

ADR	IMDG	IATA	ADN	RID
14.1. UN number				
UN 3358	UN 3358	UN 3358	UN 3358	UN 3358
14.2. UN proper shipping name				
REFRIGERATING MACHINES	REFRIGERATING MACHINES	REFRIGERATING MACHINES	REFRIGERATING MACHINES	REFRIGERATING MACHINES





SAFETY DATA SHEET

according to Regulation (EC) No. 1907/2006

HFC-32, R-32



Version 1, Revision Date 05.07.2022

Transport document description				
UN 3358 REFRIGERATING MACHINES, 2.1, (D)	UN 3358 REFRIGERATING MACHINES, 2.1	UN 3358 REFRIGERATING MACHINES, 2.1	UN 3358 REFRIGERATING MACHINES, 2.1	UN 3358 REFRIGERATING MACHINES, 2.1
14.3. Transport hazard class(es)				
2.1	2.1	2.1	2.1	2.1
		Not applicable		
14.. Packing Group				
Not applicable	Not applicable	Not applicable	Not applicable	Not applicable
14.5. Environmental hazards				
Dangerous for the environment : No	Dangerous for the environment : No Marine pollutant : No	Dangerous for the environment : No	Dangerous for the environment : No	Dangerous for the environment : No
No supplementary information available				

14.6. Special precautions for user

Overland transport

Classification code (ADR)	: 6F
Special provisions (ADR)	: 291
Limited quantities (ADR)	: 0
Excepted quantities (ADR)	: E0
Packing instructions (ADR)	: P003
Special packing provisions (ADR)	: PP32
Mixed packing provisions (ADR)	: MP9
Transport category (ADR)	: 2
Special provisions for carriage - Loading, unloading and handling (ADR)	: CV9
Special provisions for carriage - Operation (ADR)	: S2
Tunnel restriction code (ADR)	: D
EAC code	: 2YE

Transport by sea

Special provisions (IMDG)	: 291
Packing instructions (IMDG)	: P003
Special packing provisions (IMDG)	: PP32
EmS-No. (Fire)	: F-D
EmS-No. (Spillage)	: S-U
Stowage category (IMDG)	: D

SAFETY DATA SHEET

according to Regulation (EC) No. 1907/2006

HFC-32, R-32



Version 1, Revision Date 05.07.2022

Air transport

PCA Limited quantities (IATA)	: Forbidden
PCA limited quantity max net quantity (IATA)	: Forbidden
PCA packing instructions (IATA)	: Forbidden
PCA max net quantity (IATA)	: Forbidden
CAO packing instructions (IATA)	: Forbidden
CAO max net quantity (IATA)	: Forbidden
Special provisions (IATA)	: A103
ERG code (IATA)	: 10L

Inland waterway transport

Classification code (ADN)	: 6F
Special provisions (ADN)	: 291
Limited quantities (ADN)	: 0
Excepted quantities (ADN)	: E0
Equipment required (ADN)	: PP, EX, A
Ventilation (ADN)	: VE01
Number of blue cones/lights (ADN)	: 1

Rail transport

Classification code (RID)	: 6F
Special provisions (RID)	: 291
Limited quantities (RID)	: 0
Excepted quantities (RID)	: E0
Packing instructions (RID)	: P003
Special packing provisions (RID)	: PP32
Mixed packing provisions (RID)	: MP9
Transport category (RID)	: 2
Special provisions for carriage - Loading, unloading and handling (RID)	: CW9
Colis express (express parcels) (RID)	: CE2
Hazard identification number (RID)	: 23

14.7. Transport in bulk according to Annex II of Marpol and the IBC Code

Not applicable

SECTION 15: Regulatory information

15.1. Safety, health and environmental regulations/legislation specific for the substance or mixture

15.1.1. EU-Regulations

No REACH Annex XVII restrictions

Difluoromethane is not on the REACH Candidate List

Difluoromethane is not on the REACH Annex XIV List

Difluoromethane is not subject to REGULATION (EU) No 649/2012 OF THE EUROPEAN PARLIAMENT AND OF THE COUNCIL of 4 July 2012 concerning the export and import of hazardous chemicals.

Difluoromethane is not subject to Regulation (EC) No 850/2004 of the European Parliament and of the Council of 29 April 2004 on persistent organic pollutants and amending Directive 79/117/EEC

15.1.2. National regulations

Listed on the AICS (Australian Inventory of Chemical Substances)

Listed on the Canadian DSL (Domestic Substances List)

Listed on IECSC (Inventory of Existing Chemical Substances Produced or Imported in China)

Listed on the EEC inventory EINECS (European Inventory of Existing Commercial Chemical Substances)

Listed on the Japanese ENCS (Existing & New Chemical Substances) inventory

Listed on the Japanese ISHL (Industrial Safety and Health Law)

Listed on NZIoC (New Zealand Inventory of Chemicals)

Listed on PICCS (Philippines Inventory of Chemicals and Chemical Substances)

Listed on the United States TSCA (Toxic Substances Control Act) inventory

SAFETY DATA SHEET

according to Regulation (EC) No. 1907/2006

HFC-32, R-32



Version 1, Revision Date 05.07.2022

Listed on INSQ (Mexican National Inventory of Chemical Substances)

Listed on the TCSI (Taiwan Chemical Substance Inventory)

Germany

12th Ordinance Implementing the Federal Immission Control Act - 12.BImSchV

: Is not subject of the 12. BImSchV (Hazardous Incident Ordinance)

Netherlands

SZW-lijst van kankerverwekkende stoffen

: The substance is not listed

SZW-lijst van mutagene stoffen

: The substance is not listed

NIET-limitatieve lijst van voor de voortplanting giftige stoffen – Borstvoeding

: The substance is not listed

NIET-limitatieve lijst van voor de voortplanting giftige stoffen – Vruchtbaarheid

: The substance is not listed

NIET-limitatieve lijst van voor de voortplanting giftige stoffen – Ontwikkeling

: The substance is not listed

Denmark

Danish National Regulations

: Young people below the age of 18 years are not allowed to use the product

15.2. Chemical safety assessment

No chemical safety assessment has been carried out

SECTION 16: Other information

Issue date : 18-Jan-2021

Revision date : 07-july-2022

Full text of H- and EUH-statements:

Flam. Gas 1	Flammable gases, Category 1
Press. Gas (Liq.)	Gases under pressure : Liquefied gas
H220	Extremely flammable gas.
H280	Contains gas under pressure; may explode if heated.

Key or legend to abbreviations and acronyms used in the safety data sheet

ADR : European Agreement Concerning the International Carriage of Dangerous Goods by Road

IMDG : International Maritime Dangerous Goods

IATA : International Air Transport Association

AND : European Agreement Concerning the International Carriage of Dangerous Goods by Inland Waterway

RID : Regulations Concerning the International Carriage of Dangerous Goods by Rail

PBT : Persistent, Bioaccumulative and Toxic

vPvB : Very Persistent and Very Bioaccumulative

DNEL : Derived No Effect Level

PNEC : Predicted No Effect Concentration

LC50 : Lethal Concentration 50

LD50 : Lethal Dose 50

EC50 : Effective Concentration 50

TWA : Time Weighted Average

STEL : Short Term Exposure Limit

Key literature references and sources for data

ECHA: <http://echa.europa.eu/>

IFA GESTIS: [http://gestis-en.itrust.de/nxt/gateway.dll?f=templates\\$fn=default.htm\\$vid=gestiseng:sdbeng](http://gestis-en.itrust.de/nxt/gateway.dll?f=templates$fn=default.htm$vid=gestiseng:sdbeng)

HSDB: <http://toxnet.nlm.nih.gov/newtoxnet/hsdb.htm>

ICSC: <http://www.ilo.org/dyn/icsc/showcard.home>

eChemPortal: http://www.echemportal.org/echemportal/index?pageID=0&request_locale=en

NITE-CHRIP: http://www.nite.go.jp/en/chem/chrip/chrip_search/srhInput

SDS EU (REACH Annex II) *This information is based on our current knowledge and is intended to describe the product for the purposes of health, safety and environmental requirements only. It should not therefore be construed as guaranteeing any specific property of the product*

