

CE-D09 Spare parts list

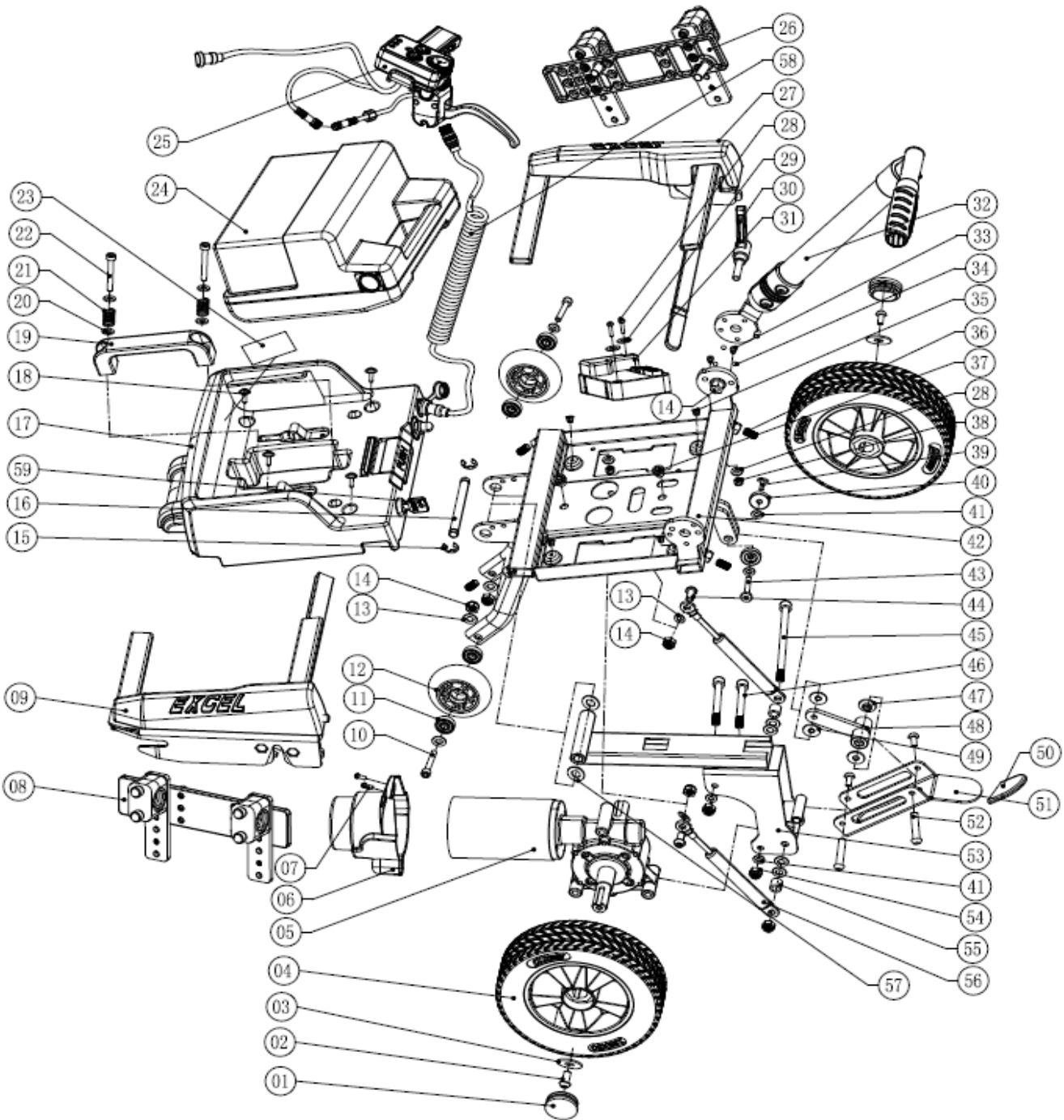

Identification number: TCF-VOMNL- 0810-02B
Product group: Power pack
Productname: Click & go Compact II
Batchnumber:

Complete



CE-D09 Spare parts list



Identification number: TCF-VOMNL- 0810-02B
 Product group: Power pack
 Productname: Click & go Compact II
 Batchnumber:

Complete

Drawing No.	Item No.	Description	Purchase Price
01	ZA11P520	Cover cap for wheel (Grey)	€ 8,90
02 to 03	-	Not available as spare part	-
04	ZA14A203	Driving wheel assembly(solid,8", Round)	€ 85,50
	ZA14A204	Driving wheel assembly(solid,8", Flat)	€ 85,50
	ZA14E201AK0	Driving wheel assembly (air,8")	€ 138,00
05	RA10E104AK0	Transaxle assembly with motor and brake	€ 748,89
05-1	RA10A106AK0	Gearbox only(30:1)	€ 340,20
05-2	RA10A103AK0	Motor only(ZE-5065D24:250W)	€ 304,56
05-3	RA10A301BK0	EM Motorbrake(3NM)	€ 106,92
06	ZA14P510	Cover Cap Motorbrake	€ 24,41
07	-	Not available as spare part	-
08	ZA14Z113	Mounting set incl. adaptionplate LEFT	€ 116,20
09	ZA14E105JK0	Width-adjustable mounting plates Left	€ 102,60
10 to 11	-	Not available as spare part	-
12	3070503020	Anti-tip wheel(3")	€ 24,41
13 to 16	-	Not available as spare part	-
17	ZA14E109	Battery receiver assembly 2nd generation (round)	€ 219,36
17-1	SE06A628	Key switch	€ 40,68
17-2	ZA14F602	Circuit breaker 35A	€ 40,68
17-3	ZA14F615AK0	Round male connector to match the hand controller	€ 22,68
17-4	ZA14P501F3C	Battery box receiver plastic only(Grey)	€ 58,32
19 to 22	ZA14A501A00	Handle for battery box receiver	€ 6,48
24	93813120	Battery box assembly(without battery)(Blue)	€ 108,50
24-1	SE06A610	Charging port	€ 12,20
-	ZA11F601	Battery cable	€ 65,10
-	ZA11F602	Fuse holder	€ 77,31
-	93810321	Battery 12Ah/12V, closed, maintenance free, AGM	€ 98,22
-	93810350	Charger 2Ah/24V	€ 233,80
25	ZA14E114	Handle controller assembly with round connector(third generation)	€ 246,24
	ZA14E113	Handle controller assembly with round connector(second generation)	€ 246,24
25-1	ZA11E120	Controll pannel(Grey)(third generation with round connector)	€ 113,22
	ZA11E110	Controll pannel (with square connector)	€ 113,22
25-2	ZA11P509	Controll pannel holder(Blue)	€ 9,77
25-3	ZA11P515	Mounting bracket set(Blue)	€ 15,47
25-4	ZA11E116	Throttle handle(Grey)(second generation with round connector)	€ 99,07
26	ZA14Z114	Mounting set incl. adaptionplate Right	€ 116,20
27	ZA14E106JK0	Width-adjustable mounting plates Right	€ 102,60
30	311120802B	Height adjustment lever	€ 9,72
31	3051600010	Controller(PG S-45A)	€ 297,20
32	ZA14E111-4	Releasebar (fourth generation)	€ 212,28
42	ZA14A101KG0	Main frame	€ 203,58
50	ZA14P508	Lock bracket cover(Green)	€ 4,07
51 to 55	-	Not available as spare part	-
56	93810700	Gas spring	€ 29,05
58	ZA14F610	Spiral adapter wire with round connector	€ 36,62
	ZA14F604	Cable between controller and spiral cable (square)	€ 29,05
	ZA14F607	Cable between controller and spiral cable (round)	€ 29,05
59	99311060	Key set(a pair)	€ 6,78

CE-D09 Spare parts list

Identification number: TCF-VOMNL- 0810-02B
Product group: Power pack
Productname: Click & go Compact II
Batchnumber:

-	ZA14F601	Cable for connecting key switch	€	20,35
-	ZA14F603	Cable for slide in batterybox	€	8,13
-	93810922	Universal mounting set for tube diameter 19 mm	€	146,93
-	93810923	Universal mounting set for tube diameter 22 mm	€	146,93
-	93810924	Universal mounting set for tube diameter 25 mm	€	146,93