

Arc



Overview



The premium smart soundbar for TV, movies, music, and more—

- Feel sound all around you with the spacious 3D experience of Dolby Atmos.
- Stream music, radio, podcasts, and more when the TV is off.
- Effortless setup with just two cables and smart **Trueplay™** tuning.
- Elegant design discreetly mounts to the wall or sits on a credenza beneath the TV.
- Flexibility to expand your system over time and enjoy true **surround sound** and multi-room listening.
- Control your Sonos system with the **Sonos app** (for Android and iOS).
- See **Setup** when you're ready to add Arc to your system.

Controls and lights



Volume control

- Volume up (right)
- Volume down (left)

Touch for small adjustments or hold to quickly adjust the volume.

Note: You can also use the **Sonos app**, your voice, or your TV remote.



Play/Pause

Touch to play or pause sound.

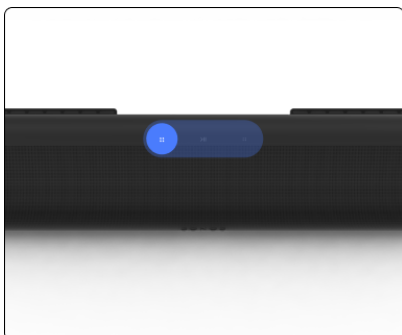

Next/Previous
(music only)

- Swipe right to skip to the next song.
- Swipe left to go to the previous song.

Note: You can't skip forward or go back when listening to a radio station.



Microphone

Tap to turn the microphone on or off:

- When the microphone light is on, voice control is on and your voice service is ready to respond.
- When the light is off, voice control is off.

Note: If you've installed a voice service and the microphone is off, you can still use voice commands. Just press and hold —no need to start with a wake word. When you release the microphone button, voice control turns off again.

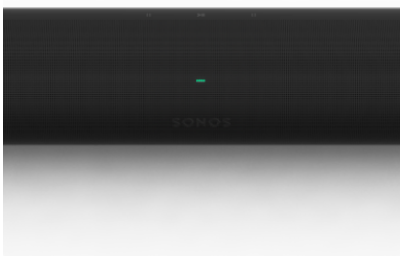

Status light

Displays the product's connection to WiFi, indicates when the volume is muted, and signals errors. [Learn more](#)

Note: If you don't want to allow playback or volume adjustments using the speaker touch controls, you can disable them in the room's settings.

Connector panel



1

HDMI port

Use to connect Sonos Arc to your TV.

2

Join button

Press to connect during setup.

3

Ethernet port

Use an Ethernet cable if you want to connect to a router, computer, or network-attached storage (NAS) device (optional).

4

AC power (mains) input

Use only the supplied power cord (using a third-party power cord will void your warranty).

Note: Insert the power cord firmly until it is flush with the speaker.

Select a location

You can wall mount Arc below your TV or place it in or on a TV stand.

TV stand placement

- Place horizontally on a stable and level surface.
- Keep 4" (102mm) space (minimum) between the top of the soundbar and the bottom of your TV (if placing soundbar below the TV).
- Don't place vertically or on its side.
- Make sure the touch controls are facing up.

Wall mount

You can secure the soundbar to a wall with a compatible wall mount. We recommend the custom-designed Sonos Arc Wall Mount (sold separately). See [wall mount](#).

Connect the cables

Before you start

- Disconnect existing home theater or surround sound equipment from your TV.
- Connect any external devices, like a cable box or DVD player, directly to your TV.
- Turn your TV on.

1

Connect the power cord and plug in the soundbar.

Note: Use only the supplied power cord (using a third-party power cord will void your warranty).

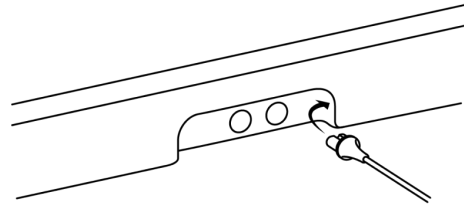

2

Connect the HDMI cable (included) to the soundbar's HDMI port.

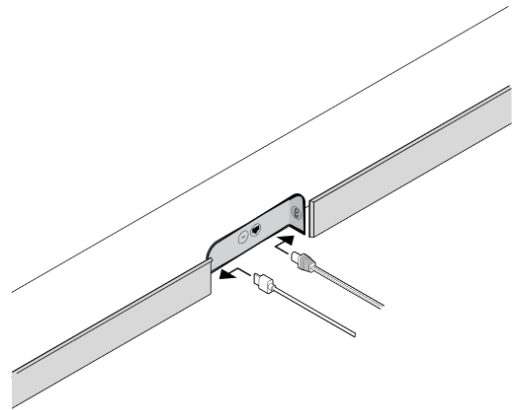

Connect the HDMI cable to your TV:

- **If your TV has an HDMI ARC (or eARC) port**, connect the HDMI cable to it.

(HDMI ARC is a special port that looks like a standard HDMI port—it may be on the back or side of your TV. The ports look similar, but the ARC port will be labeled ARC, eARC, or ARC/eARC. If you connect the Sonos soundbar to a standard HDMI port instead, you won't hear any sound).

- **If your TV doesn't have an HDMI ARC or eARC port**, you'll need to use the optical adapter:
 - Remove the protective cap from the optical adapter, then attach the optical adapter to the HDMI cable.
 - Connect the optical adapter to your TV's optical digital OUT port. (The TV's optical adapter's port is "D-shaped"—make sure the connector aligns correctly into the port. Inserting the adapter incorrectly may damage the cable).

TV with ARC/eARC port

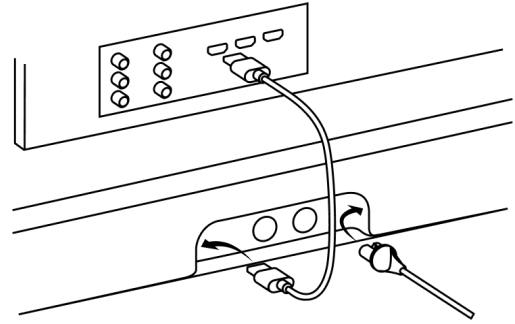

Optical adapter (if needed)

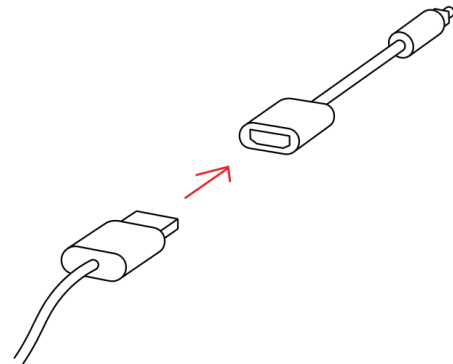

Voice services

Use your voice to control your Sonos system with any voice-enabled Sonos product—play and control content, turn the volume up or down, and more.

- **Sonos Voice Control:** control your whole Sonos system with hands-free ease and unmatched privacy. Sonos Voice Control comes ready to use—it only takes a few seconds to add when you set up your speakers. [More information](#)
- **Amazon Alexa:** you'll need the Sonos app and the Alexa app with the Sonos skill enabled. You'll make some changes in both apps during setup. [Learn more](#)
- **Google Assistant:** you'll need the Sonos app and the Google Assistant app. You'll make some changes in both apps during setup. [Learn more](#)
- **Siri:** you'll need the Apple Home app. Add your AirPlay2-compatible Sonos speakers to the Apple Home app and then use an iPhone, iPad, or Apple TV to ask Siri to play music (currently limited to Apple Music). [Learn more](#)

Note: Voice control isn't supported in every country yet—this feature will be available as soon as Sonos and a voice service launch together in your region.

Microphone on/off

The microphone is used for voice control and for microphone-dependent features like Trueplay tuning. Press  to turn the microphone on or off—the microphone LED light will let you know when your voice assistant is listening.

When the microphone light is on:

- If you set up a voice service, voice control is on and ready to respond.
- Microphone-dependent features like [Trueplay](#) are available.

When the microphone light is off:

- If you set up a voice service, voice control is off.
- Microphone-dependent features like Trueplay are unavailable.

Trueplay™

Every room is different. Trueplay tuning measures how sound reflects off walls, furnishings, and other surfaces in a room, then fine tunes your Sonos speaker to make sure it sounds great no matter where you've placed it.

Trueplay works on iOS mobile devices running iOS 8 or later. During tuning, you'll move around the room holding your mobile device.

1. Select  > **System**, and pick the room you want to tune.
2. Choose **Trueplay Tuning** to get started.

Auto Trueplay

Portable Sonos products like Sonos Roam and Move can tune themselves automatically. Auto Trueplay uses your speaker's microphone to detect the environment and make periodic tuning adjustments so you get great sound wherever your speaker is and whatever you're listening to.

Go to  > **System**, and select your portable speaker to turn on auto Trueplay.

Product settings

You can customize Sonos products for your surroundings. Go to  > **System** and select a product.

Room Name

If you move your speaker to a new room, you can change its name in **Settings**.

Turn off WiFi

(not available for Sonos Era 100, Era 300, or portable products)

You can turn off your speaker's WiFi when it's connected to your network with an Ethernet cable. This reduces power consumption and can improve connectivity for wired speakers.

For products like Amp and Port, turning off WiFi can reduce the internal temperature when they're placed in a rack or stacked. [Learn more](#)

Note: WiFi is turned off for Era 100 and Era 300 when you connect a **[Sonos Combo Adapter](#)** using the Ethernet cable.

EQ

Sonos products ship with preset equalization settings. You can change the sound settings (bass, treble, or loudness) to suit your personal preferences. [Learn more](#)

Trueplay

Trueplay adapts the sound for your surroundings and content. Portable products can tune themselves automatically. [Learn more](#)

Volume Limit

You can set a maximum volume for each room. [Learn more](#)

Status Light

Displays the speaker's connection to WiFi, indicates when the volume is muted, and signals errors. [Learn more](#)

Note: If the light is distracting, you can turn it off in **Settings**.

Touch Controls

You can disable the touch control on your speaker. You may want to do this to prevent a child or curious pet from accidentally adjusting playback or volume. [Learn more](#)

Battery Saver

(portable products only)

To save battery life, you can set your portable speaker to power off automatically instead of going to sleep. It won't appear in the Sonos app until it's powered back on.

When a projector, turntable, stereo, or other audio device is connected to a Sonos product, you can adjust these line-in settings:

- **Source name:** Choose a name for the line-in device.
- **Source level:** Adjust the line-in source level if you find the default volume setting is too quiet or distorted.
- **Audio Delay:** Add a delay between the line-in source and Sonos to reduce the chance of audio issues occurring when you're playing line-in audio on grouped speakers.
- **Autoplay:** Choose a room if you want line-in audio to start playing automatically when Sonos detects a signal on the line-in port.

Line-In

(Sonos products with line-in capability)

Home theater

Sonos products for your TV provide full-theater sound and play music too. Create a home theater system by adding a pair of [rear surrounds](#) and a [Sub](#).

Home theater settings

Use the Sonos app to adjust sound settings or change the way your home theater speaker works with your TV.

TV Dialog Sync

If the TV audio is out of sync with the video, you can adjust the audio delay (lip sync) in your room's settings. [Learn more](#)

Group Audio Delay

If you notice audio issues when playing to a group, you can adjust this setting. [Learn more](#)

TV Autoplay

TV Autoplay—if music or other content is playing when you turn on your TV, the audio automatically switches to TV audio (default). If you don't want this to happen, turn off TV Autoplay in your room's settings.

Ungroup on Autoplay—if your home theater speaker is grouped with other products when you turn on the TV, it automatically drops from the group (default). If you don't want this to happen, turn off Ungroup on Autoplay in your room's settings.

Speech enhancement

Makes TV dialog easier to hear. [**Learn more**](#)

Night sound

Enhances quiet sounds and reduces the intensity of loud sounds. Turn on to reduce the volume while still experiencing proper balance and range. [**Learn more**](#)

Remote Control Setup

During setup, you'll program a remote control. You can program a different remote control any time. [**Learn more**](#)

Set up surrounds

It's easy to turn two Sonos speakers (same model), or a Sonos Amp and your favorite non-Sonos speakers, into separate right and left channels for your home theater.

1. Place each surround speaker about 10 ft from your favorite listening position, angling them toward the seating area.
2. Go to  > **System**.
3. Select a room with a soundbar and choose **Add Surrounds** to get started.

Note: If you group the rooms or create a stereo pair instead, you won't have surround sound.

[Learn more](#)

Surround audio settings

During setup, surround sound is optimized for your room. These settings are adjustable:

Surrounds

Turn surround sound **On** or **Off**.

TV Level

Adjust surround volume for TV audio.

Music Level

Adjust surround volume for music.

Music Playback

Ambient (subtle) or **Full** (louder, full range). Doesn't apply to Dolby Atmos Music playback.

Accessories

Find the perfect accessory for your Sonos system—tailored to perfectly fit your Sonos products.

For a full selection of Sonos-compatible stands, wall mounts, chargers and cables, see [**Accessories**](#) on our website.

Wall mount

Guidelines

- Use the Sonos Arc wall mount kit (sold separately on www.sonos.com). Follow the instructions in the kit.
- Keep 4.0" (102 mm) space (minimum) between Arc/Arc SL and your TV.
- Make sure the touch controls are facing up.
- For best sound quality, keep both ends of the soundbar at least 1' (30cm) from a wall or other obstructions.

Mount kit contents

- Wall mount bracket
- Positioning guide (don't discard—it may look like packing material)
- 2 knobs
- 6 wall anchors
- 6 screws

Wall Material	Pre Drill
Wood stud	1/8" / 3mm bit
Drywall (no stud)	5/16" / 8mm bit
Plaster	5/16" / 8mm bit
Concrete or brick	5/16" / 8mm bit

1

If your TV is wall-mounted, place the positioning guide against the wall, aligning the top edge with the bottom of your TV. There should be 5.5" (140mm) between the top of the wall mount bracket and the TV.

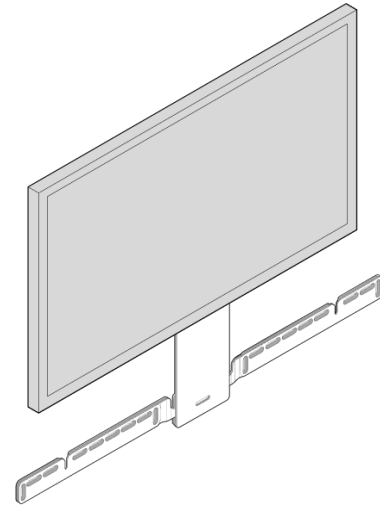

2

Mark the screw locations and remove the guide.

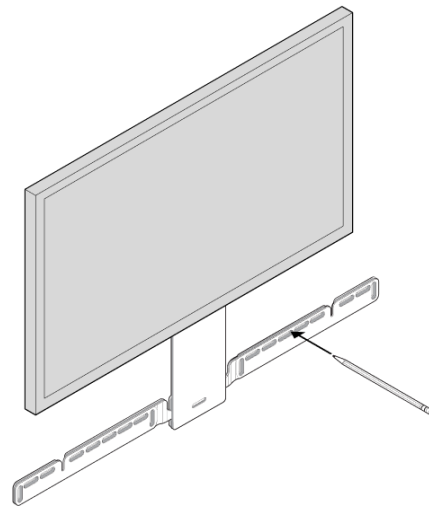

3

If you're using the included wall anchors, use a 5/16" drill bit to drill the pilot holes and then insert the wall anchors. Don't use the anchors if you're drilling into wood or plastic.

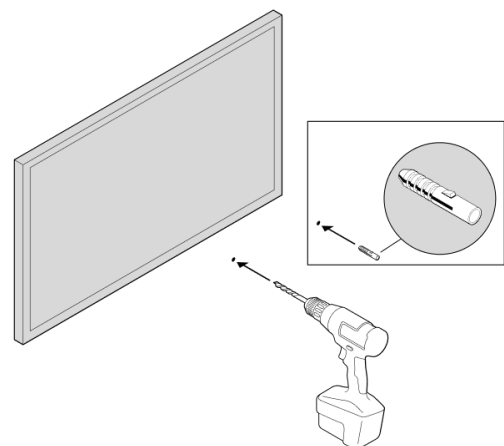

4

Position the wall mount bracket over the marked screw locations, using a level to confirm accuracy. Use a Phillips-head screwdriver or a power drill to screw the bracket to the wall, making sure the arrows in the center are pointing up.

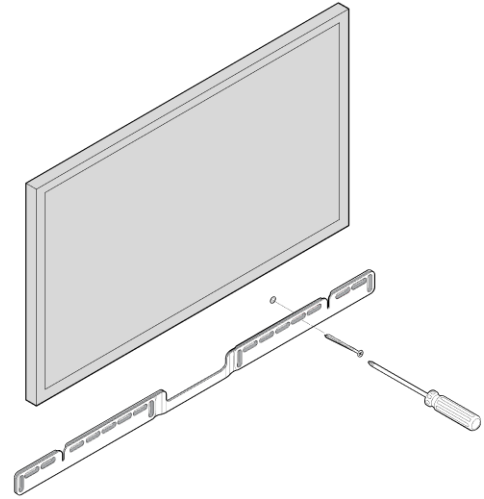

5

Screw the 2 knobs into the back of the soundbar until they are fully tightened.

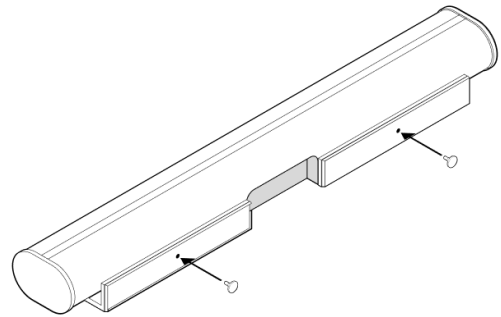

6

Connect the power and HDMI cables to the back of the soundbar.

Note: If you're connecting the cables to the TV at this time, be sure to plug the HDMI cable into the HDMI ARC or eARC port on your TV.

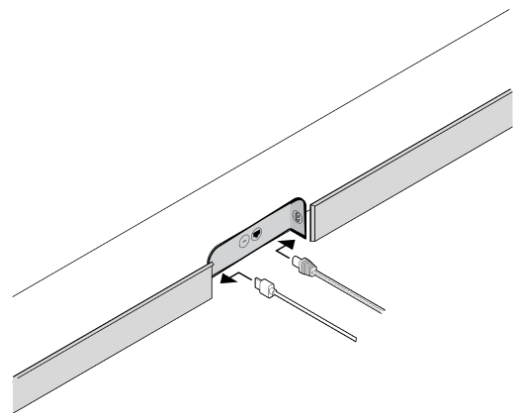

7

Slide the soundbar down so the knobs fit into the slots on the wall bracket. Make sure the touch controls are facing up and the soundbar is fully seated.

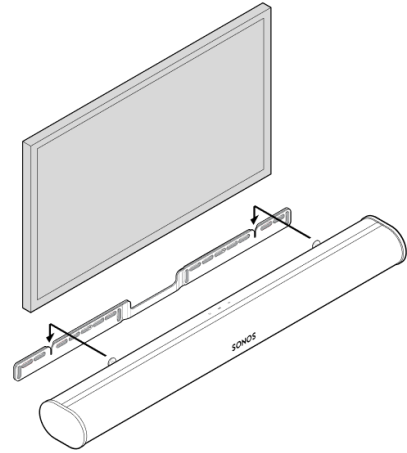

Specifications

Feature	Description
---------	-------------

AUDIO

Amplifier	Eleven Class-D digital amplifiers.
------------------	------------------------------------

Elliptical woofer	Eight full-range woofers ensure you'll hear the faithful playback of mid-range vocal frequencies plus deep, rich bass.
--------------------------	--

Tweeter	Three silk dome tweeters create a crisp and clear high-frequency response.
----------------	--

Microphones	<ul style="list-style-type: none">• Four microphone array.• LED hardwired to voice microphones for privacy control so you know when the microphone is active.
--------------------	--

Voice control	Integrated voice control.
----------------------	---------------------------

System requirements	TV with HDMI ARC or optical digital audio output, broadband internet, and the Sonos app.
----------------------------	--

NETWORKING*

Feature**Description**

Wireless connectivity

Connects to WiFi network with any 802.11 b/g/n, 2.4GHz broadcast-capable router.

Ethernet port

One 10/100Mbps Ethernet port. You can wire directly to your router if your WiFi is unstable.

SOFTWARE

Trueplay™

Dynamically tunes the speaker to the unique acoustics of the room or area (iOS device required).

Speech enhancement

Turn on this home theater setting in the Sonos app to make TV dialogue even clearer.

Night sound

Turn on this home theater setting to reduce the intensity of loud TV sound effects.

GENERAL

Power supply

Auto-switching 100-240V, 50-60Hz 3.5A AC universal input.

Dimensions (H x W x D)

3.4 x 45 x 4.5in. (87 x 1141.7 x 115.7mm)

Feature	Description
Weight	13.78lb (6.25kg)
Operating temperature	32°F to 104°F (0°C to 40°C)
Storage temperature	-4°F to 122°F (-20°C to 50°C)
Control	You can use your TV remote, voice, speaker touch controls, or the Sonos app.
Supported devices	Connects to TV with HDMI cable (with or without an attached optical adapter). Plays sources connected to the TV, including cable boxes and game consoles.
Package contents	Sonos Arc, power cord, HDMI cable, optical audio adapter, Quickstart Guide.

*Specifications subject to change without notice.

Important safety information

1. Read these instructions.
2. Keep these instructions.
3. Heed all warnings.
4. Follow all instructions.
5. Do not use this apparatus near water.
6. Clean only with dry soft cloth. Household cleaners or solvents can damage the finish on your Sonos products.
7. Do not block any ventilation openings. Install in accordance with the manufacturer's instructions.
8. Do not install near any heat sources such as radiators, heat registers, stoves, or other apparatus that produce heat.
9. Protect the power cable from being walked on or pinched, particularly at plugs, convenience receptacles, and the point where they exit from the apparatus.
10. Only use attachments/accessories specified by the manufacturer.
11. Unplug this apparatus during lightning storms or when unused for long periods of time.
12. This product does not have any user-serviceable parts. Do not open or disassemble or attempt to repair it or replace any components. Refer all servicing to Sonos qualified service personnel. Servicing is required when the apparatus has been damaged in any way, such as power-supply cable or plug is damaged, liquid has been spilled or objects have fallen into the apparatus, the apparatus has been exposed to rain or moisture, does not operate normally, or has been dropped.
13. The Mains plug should be readily available to disconnect the equipment.
14. **Warning:** To reduce the risk of fire or electric shock, do not expose this apparatus to rain or moisture.
15. Do not expose apparatus to dripping or splashing and do not place objects filled with liquids, such as vases, on the apparatus.