

Thank you for choosing ROADLOK to protect your motorcycle. It is extremely important that the system is installed correctly, so read thoroughly to understand the installation process of your system.

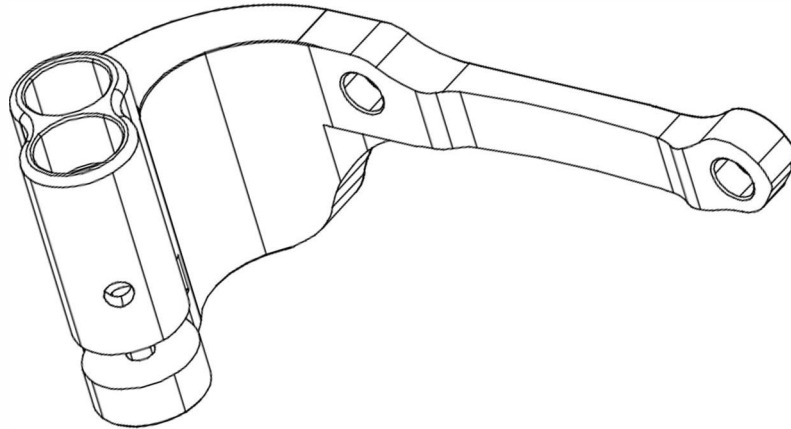

STOP

It is advisable to register your ROADLOK system before installation.

There are over 700,000 combinations for the keys, and if lost, duplicates cannot be cut without the code on the metal tag attached to the supplied keys.

Register at: www.roadlok.com/registration

!

The ROADLOK is installed on your vehicle's braking system and therefore must be installed by a trained technician with a thorough understanding of motorcycle braking systems!

Improper installation of the system can severely compromise the safety of your motorcycle. Improper installation can lead to a loss of control or wheel lock up, with subsequent serious accident and injury or even death. If you have any question about the proper installation of your system do not ride your motorcycle. Take it to a local dealership who will have the appropriate tools and equipment to properly and safely install the system.

!

If you do not feel that you have the technical expertise to install this locking system, please visit your local trusted motorcycle dealer or service centre for proper installation.

INSTALLATION

1. Undo the top retaining bolt from your front caliper on the side corresponding with your lock model (left or right). Loosen the bolt entirely, but do not remove the bolt from the caliper.

With the bolt remaining within the caliper, hold the bolt firmly against the inner threads of the lower fork leg. DO NOT BEGIN TO RETHREAD THE BOLT.

2. MEASURE:

With the bolt in this position, measure the distance between the underside of the head of the bolt and the top surface of the caliper (figure A). This is the amount of thread that is necessary to properly secure the front caliper according to the manufacturer of your motorcycle.

Note: this measurement is needed for installing the special mounting hardware included with the ROADLOK system.

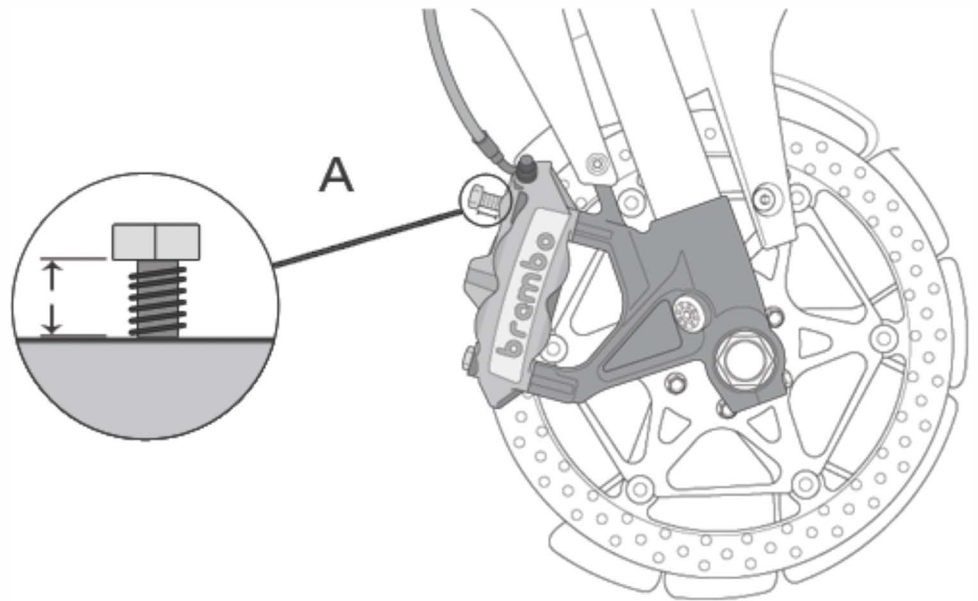

3. Your system includes 2 bolt sizes (80mm and 90mm), various sized spacers (see **Measuring Card** included with your kit) and 5mm shims. The spacers are used to align the ROADLOK body so that the Brake Bolt pin properly passes through a rotor vent hole. The shims can be combined with the 90mm bolts to provide an 85mm effective bolt length if neither bolts size allows for proper fitment. Each spacer is assigned a letter indicating the thickness needed to adjust the distance between the ROADLOK and the caliper. Use the spacer measuring card to determine which spacer you are using.

Start the installation attempt with the "A" spacer and work your way through the selection of spacers, using only hand-tightening of the bolts while testing fitment, until the Brake Bolt pin passes through the rotor vent hole smoothly.

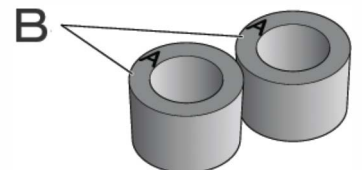

4. Place both spacers (C) between the ROADLOK (E) and the mounting points on the caliper (F). Insert two supplied mounting bolts (D) Mm x 80 through the ROADLOK body, through the spacers and caliper and into the fork leg. Tighten the mounting bolt closest to the key cylinder by hand. DO NOT THREAD THE UPPER BOLT INTO THE MOUNTING HOLE.

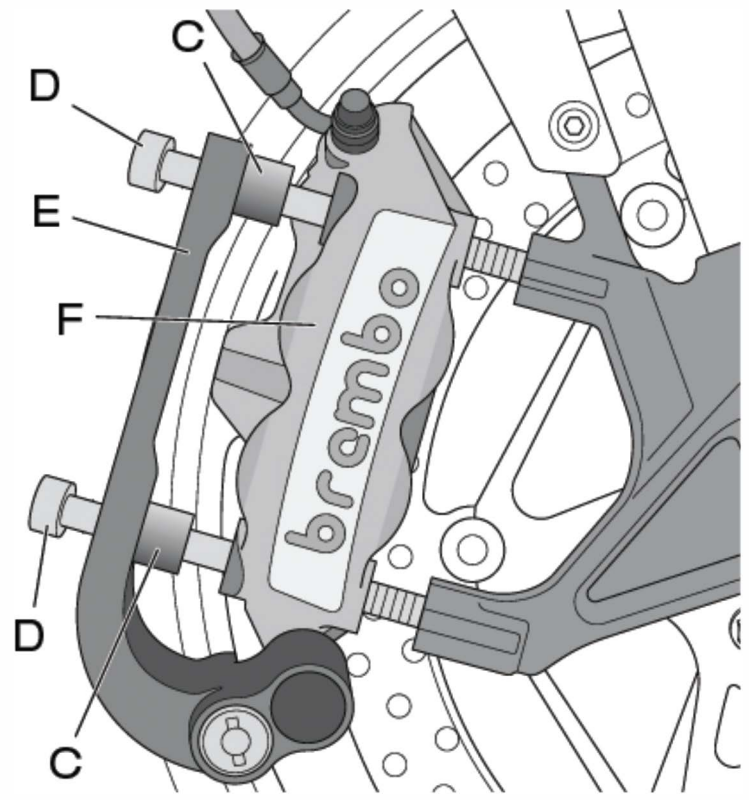

5. MEASURE:

With the upper mounting bolt pressed against the internal threads, measure the distance between the mounting surface of the ROADLOK and the head of the bolt (figure H). This distance MUST be equal or greater than the measurement of the original mounting bolt. This is important to ensure the safe installation of the locking system on the brake caliper.

If the distance of the new bolt thread is **less than** the distance of the original bolt thread, use the larger 90mm bolts to allow for maximum thread depth.

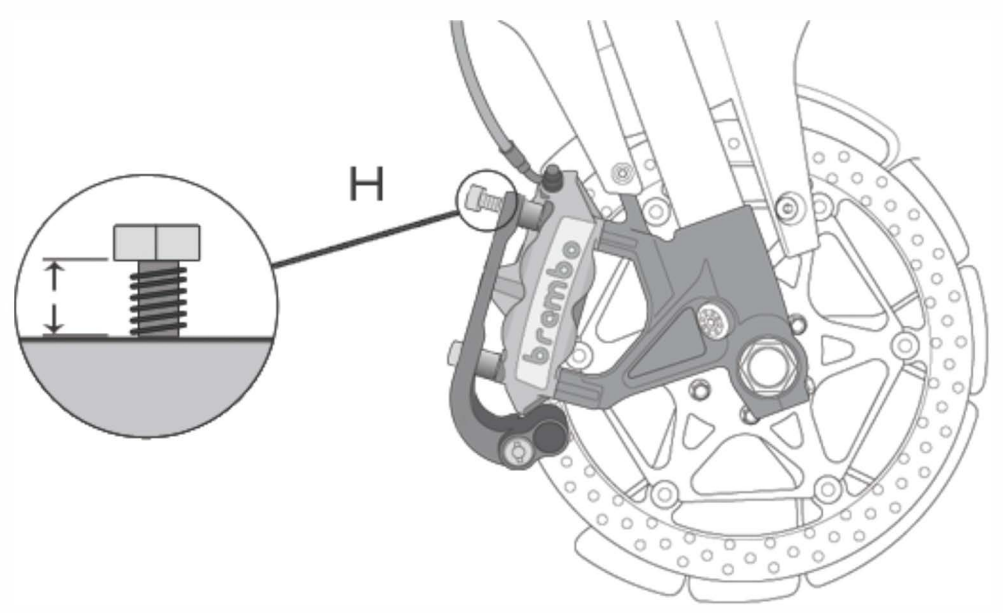

NOTE 1: If proper installation requires a thread length in between 80mm and 90mm, the included 5mm shims (X) can be used between the bolt and the ROADLOK body. Combining the 5mm shim with the 90mm bolt will result in an effective 85mm thread length, which may be more appropriate for some models.

NOTE 2: BMW kits only come with 90mm bolts. If the bolts are too long, combine them with the 5mm shims.

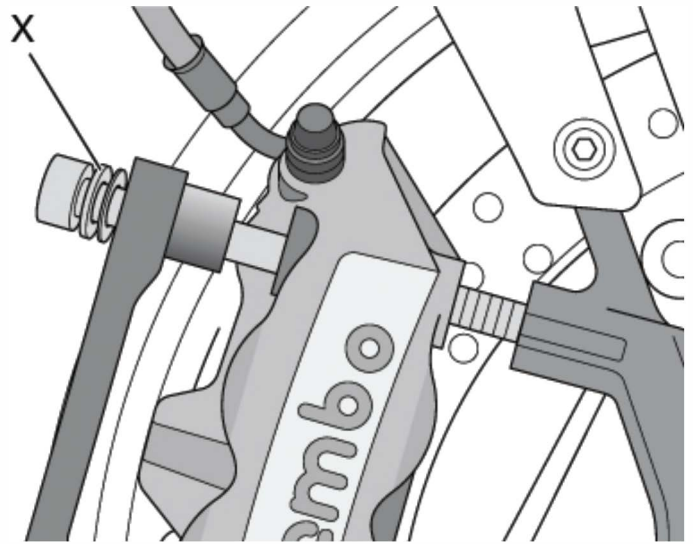

6. OPERATING THE SYSTEM:

The system is shipped with a black plug that should be used to keep unwanted dirt and debris out of the pinhole when riding.

Remove the black plug (J) with the supplied key. Insert the key into the key cylinder and rotate clock-wise. The black plug can now be removed.

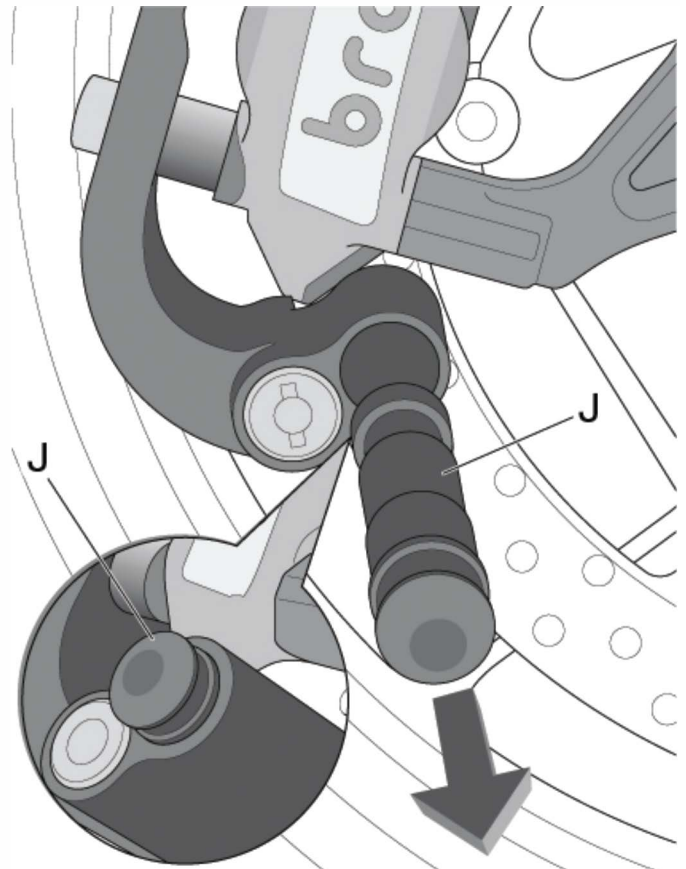

7. Insert the pin (I) into the hole where the black plug was removed. The key must remain rotated fully in the unlocked position to allow the pin to be inserted. While the pin is fully inserted being held by finger pressure, the key can be rotated anti-clockwise and removed. The cylinder uses a dead-bolt latch to hold the pin in the lock body.

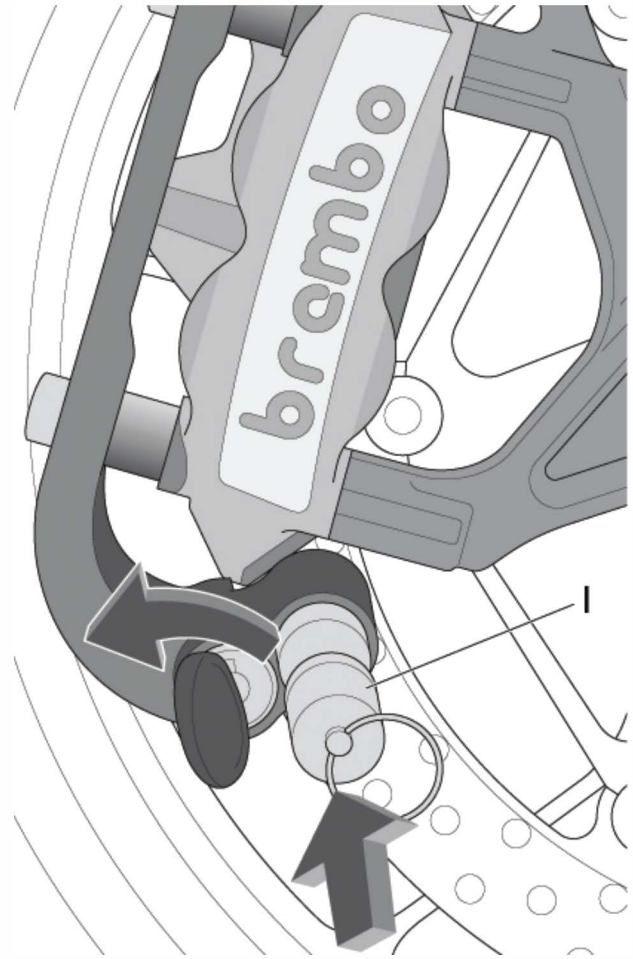

8. TESTING ALIGNMENT:

The front wheel must be rotated to allow the spring loaded pin (I) to fully extend through the vent hole in the rotor (see image). The wheel will then lock in place. If the pin does not fully extend through the vent hole (see image), repeat steps 3 through 5 using the available shims and/or spacers as required, and re-measure the mounting bolt (step 6).

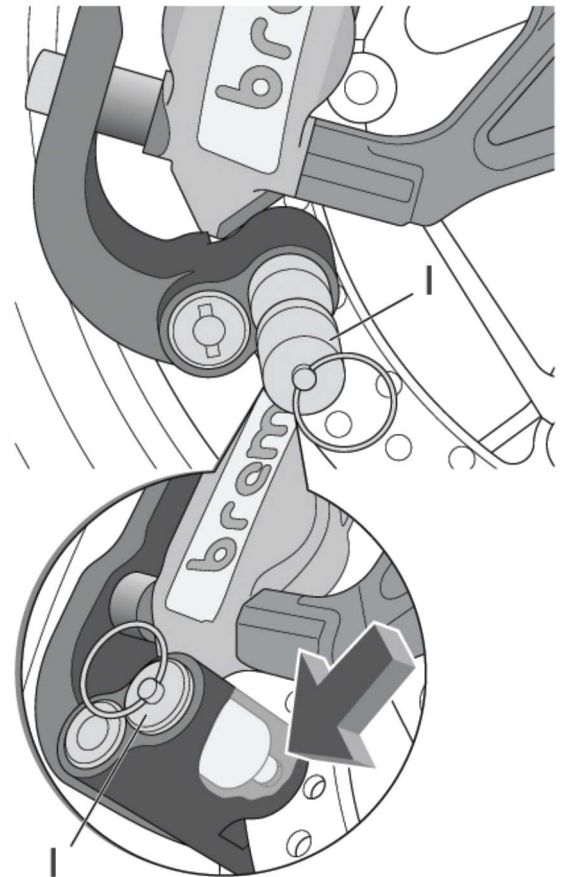

9. TORQUE:

After the correct function of the pin has been checked, torque both the upper and lower mounting bolts to securely fasten the ROADLOK, spacers and caliper to the lower fork leg. (Refer to your OEM Owner's Manual for the appropriate torque specification)

10. OPERATION:

Before riding, remove the pin (I) from the hole and replace with the black plug. NOTE: The key must remain turned fully clockwise to insert the black plug, then turn the key anti-clockwise to secure the black plug into the body.

ADDITIONAL INFORMATION

The XRA system is mounted to your front brake caliper. It is extremely important that the correct length bolts are used when securing the locking system to ensure that there is no change to the original braking system. Failure to use the correct mounting bolts could result in serious injury or death.

It is recommended that the XRA system be installed by a certified professional.

Warnings and Notifications



When parking your motorcycle on an incline or slope with an installed ROADLOK keep the transmission engaged so that the pin (I) does not take on the full load of the motorcycle.

The pin will be more difficult to remove if there is a considerable amount of force applied by the rotor vent hole. If the pin is difficult to remove due to weight from the motorcycle, relieve pressure by pushing in the opposite direction of the force on the fork leg or wheel itself, or pressing straight up on the handle bars. The pin will be able to be removed.



Check the torque of the mounting bolts periodically.



Proper maintenance of the ROADLOK includes periodically cleaning the locking cylinder. This is best accomplished with a stream of fresh water and compressed air. It is not advised to use oil as this attracts dirt and may cause the cylinder to lose performance or impede operation over time. Use of a dry lubricant such as graphite or other lock-specific formula is recommended after cleaning. If your lock cylinder is not operable, refer to your warranty information.

For Additional Support Contact: support@roadlok.com