



powered by **Haier**

Heat pump Water Heater Operation and Installation Manual



Model

HP80M8-9/B(GN-K)
HP110M8-9/B(GN-K)
HP150M8-9/B(GN-K)



Please read this manual carefully prior to your use of this water heater.
The appearance of the water heater given in this manual is for reference only.
Don't install and use the product outdoors.

Contents

1. Safety instructions	4
2. Instructions on transportation and storage.....	12
3. Functionings & principles	12
4. Technical parameters	13
5. Description of parts and components	14
6. Installation introduction	16
7. Operation and functions	28
8. Checking and maintenance.....	35
9. Faults and protection	37
10. Product Fiche	38

Dear users of KWIKOT,

Thank you for choosing KWIKOT products.

Please read this manual carefully and follow the operation and safety instruction to ensure best installation and utilization of the product.



Product safety statement:

1. This appliance can be used by persons with reduced physical, sensory or mental capabilities or lack of experience and knowledge if they have been given supervision or instruction concerning use of the appliance in a safe way and understand the hazards involved.
2. Children shall be closely supervised to make sure they stay away from this product.
3. The method of installing safety valve please refer to Page 24.
4. The water may drip from the discharge pipe of the pressure relief device and this pipe must be left open to the atmosphere.
5. The water heater is to be drained according to the instructions specified on page 36.

Arranging disposal of refrigerant

Warning: flammable hazard!



1. Please read the instructions carefully before installation and use.
2. Do not puncture or ignite this product.
3. The environment-friendly refrigerant R290 used in this product is odorless.
4. This product cannot be discarded or scrapped at will.



If necessary, please contact the after-sales team to obtain the correct disposal method. When the product is disposed of, the refrigerant in the system needs to be recovered.



5. The product should not be stored in an area containing an open flame, including an area with an open fire, gas appliance or electric heater. (e.g. open fire, ignited gas appliance, open electric heater).



6. Before the refrigeration system is repaired, the refrigerant must be removed by a licensed professional.
7. Do not use any method to accelerate the defrosting process or clean frosted components of the appliance.

Warning : Risk of damage to the environment

This heat pump contains the refrigerant R290. The refrigerant must not be allowed to escape into the atmosphere.

Refrigerant must be disposed of by qualified professional.



WARNING:







IF THE HOT WATER SYSTEM IS NOT USED FOR TWO WEEKS OR MORE, A QUANTITY OF HIGHLY FLAMMABLE HYDROGEN GAS MAY ACCUMULATE IN THE WATER HEATER. TO DISSIPATE THIS GAS SAFELY, IT IS RECOMMENDED THAT A HOT TAP BE TURNED ON FOR SEVERAL MINUTES OR UNTIL DISCHARGE OF GAS CEASES. USE A SINK, BASIN, OR BATH OUTLET, BUT NOT A DISHWASHER, CLOTHES WASHER, OR OTHER APPLIANCE. DURING THIS PROCEDURE, THERE MUST BE NO SMOKING, OPEN FLAME, OR ANY ELECTRICAL APPLIANCE OPERATING NEARBY. IF HYDROGEN IS DISCHARGED THROUGH THE TAP, IT WILL PROBABLY MAKE AN UNUSUAL SOUND AS WITH AIR ESCAPING.

Safety instructions (to be followed at any time)









Interpretation of marks and symbols

Failure to respect these instructions may lead to serious malfunctions of the device and to risks for the user







	<p>Instructions with this warning mark shall be strictly followed during operation. They relate to product and body safety of users.</p>
	<p>Information provided with this banning mark relates to activities that are definitely forbidden. Otherwise the machine may be damaged or users may risk personal danger.</p>

  <p>The water heater shall be installed in strict accordance with local wiring regulations, and equipped with power supply with a ground line. Please ensure an effective ground connection.</p>	 <p>Ground line and zero line of the power supply shall not be connected together. The ground line shall not be connected to pipeline conveying gas or water, lightning arresters or telephone lines.</p>
 <p>The water heater shall not be installed at places where water drainage is unavailable or impossible.</p>	 <p>It is recommended that the water heater shall be installed inside.</p>
 <p>This water storage tank must be equipped with a safety valve. Its installation position shall not be changed. To guarantee safe operation, it shall not be blocked at any time.</p>	 <p>While bathing, children must be under guidance of an adult person.</p>

Safety instructions (to be followed at any time)

<p> The outlet water temperature of a water heater is typically higher than the temperature indicated on the display. Hot water shall not be pointed at the human body immediately after opening the hot water valve to avoid injury caused by hot water.</p>	<p> Means for disconnection from the main supply having a contact separation in all poles that provide full disconnection under overvoltage category III conditions must be incorporated in the fixed wiring in accordance with the wiring rules.</p>
<p> Install the water heater in strict accordance with the installation instruction specified on page 16-27.</p>	<p> If the power cord is damaged, it shall be replaced by qualified professionals to avoid hazards.</p>
<p> Hands or other items shall not be put into the air grille to avoid injury or damage to the water heater.</p>	<p> Maintenance shall be carried out according to the instructions specified on page 35.</p>
<p> The water heater is intended to be permanently connected to the water mains and not connected by a hose-set.</p>	
<p> Do not install the water heater in the position where exposed to gas, vapours or dust.</p>	
<p> The inlet water pressure is between (0.1-0.5)MPa. The inlet water temperature is suggested between (10-30)°C.</p>	

Safety instructions (to be followed at any time)

<p> Rotate the safety valve handle once a month. The valve works well if there is water flowing out, otherwise check for blocking and replace the safety valve if necessary.</p>	<p> Water heaters shall be equipped with a dedicated power line and residual current circuit breakers. The action current shall not exceed 30 mA;</p>
<p> The water drain pipe shall be in connection with the atmosphere, it shall not be blocked; the water drain pipe connected to a safety valve shall be installed in a frostless environment with an continuous downwards inclination.</p>	
<p> The appliance contains greenhouse gases. Chemical name of the gas: R290/ 0,12kg Greenhouse gases are contained in hermetically sealed equipment. Global Warming Potential(GWP) : 3</p>	
<p> If needed, please refer to the wiring diagram on page 27.</p>	
<p> The method of connection about the appliance to the electrical supply refer to page 25.</p>	
<p> In accordance with safety rules, a safety valve(8bar,G1/2F) must be installed on the tank. For France, we recommend hydraulic safety units fitted with a membrane with the NF marking. The rated pressure of the safety valve shall not exceed 0.8MPa.</p>	

Safety instructions (to be followed at any time)

1. Ask your dealer or qualified personnel to carry out installation work. Do not attempt to install the product yourself. Improper Installation may result in water leakage, electric shocks, fire or explosion.
2. Keep this manual where the user can easily find it.
3. Install the product in accordance with the instructions in this installation manual.
4. Be sure to use only the specified accessories and parts for installation work.
5. Install the product on a foundation strong enough to withstand the weight of the unit.
6. Electrical work must be performed in accordance with relevant local and national regulations and with instructions in this installation manual. Be sure to use a dedicated power supply circuit only. The wiring method should be in line with the local wiring standard. The type of connecting wire is H07RN-F.
7. Use a cable of suitable length. Do not use tapped wires or an extension lead as this may cause overheating, electric shocks, fire or explosion.
8. All the cables shall have got the authentication certificate. During installation, when the connecting cables break off, it must be assured that the grounding wire is the last one to be broken off.
9. If refrigerant gas leaks during installation, ventilate the area immediately. Toxic gas may be produced if the refrigerant comes into contact with fire, and explosion may happen.
10. After completing installation, check for refrigerant gas leakage. When installing or relocating the product, be sure to bleed the refrigerant circuit to ensure it is free of air, and use only the specified refrigerant (R290).
11. Do not use means to accelerate the defrosting process or to clean, other than those recommended by the manufacturer.
12. Do not pierce or burn.
13. Be aware that refrigerants may not contain an odour.
14. Comply with national gas regulations.
15. This appliance can be used by children aged 8 years and above and persons with reduced physical, sensory or mental capabilities or lack of experience and knowledge if they have been given supervision or instruction concerning use of the appliance in a safe way and understand the hazards involved. Children shall not play with the appliance. Cleaning and user maintenance shall not be made by children without supervision. The appliance can not be discarded or scrapped Randomly.

Safety instructions (to be followed at any time)

1. Do not install the appliance at any place where there is danger of flammable gas leakage. In the event of a gas leakage, build-up of gas near the appliance may cause a fire to break out.

2. Please instruct the customer to keep the area around the unit clean. Only qualified personnel can handle, fill, purge and dispose of the refrigerant.

3. If the unit is installed in coastal areas or other regions with sulfate gas of salty atmosphere, corrosion will occur and the unit service life will be shortened.

Loading and Unloading Requirements

1) The products shall be carefully handled during loading and unloading.

2) Rude and barbarous handling such as kicking, throwing, dropping, bumping, pulling and rolling is not allowed.

3) The workers engaged in loading and unloading must be subject to necessary trainings on the potential hazards caused by barbarous handling.

4) Dry powder extinguishers or other suitable fire extinguishing apparatus within the period of validity shall be equipped at the loading and unloading site.

5) The untrained personnel cannot be engaged in loading and unloading of flammable refrigerants air conditioner.

6) Before loading and unloading, anti-static measures shall be taken, and phones cannot be answered during loading and unloading.

Transporting Management Requirements

1) The maximum transporting volume of finished products shall be determined as per local regulations.

2) The vehicles used for transporting shall be operated as per local laws and regulations.

3) Dedicated after-sales vehicles shall be used for maintenance, and exposed transporting of refrigerant cylinders and the products to be maintained is not allowed.

4) The rain cover or similar shielding material of transporting vehicles shall be provided with certain flame retardancy.

5) Leakage warning device of flammable refrigerant shall be installed inside the closed-type compartment.

Storage Requirements

1) The storage package of equipment used shall be such that no leakage of refrigerant will be caused due to mechanical damage of the equipment inside.

2) The maximum quantity of the equipment allowed to be stored together shall be determined as per local regulations.

Safety instructions (to be followed at any time)

Installation Instructions

Electrical Safety Requirements

1. The surrounding conditions (ambient temperature, direct sunlight and rainwater) shall be noticed during electrical wiring, with effective protective measures being taken.
2. Copper wire cable in line with local standards shall be used as the power line and connector wire.
3. The appliance shall be reliably earthed.
4. The dedicated branch circuit must be used, and leakage protector with sufficient capacity must be installed.

Maintenance Precautions

1. For all the faults requiring welding the refrigeration pipelines or components inside the refrigeration system of R290 refrigerant air conditioners, maintenance at the user's site is never allowed. **If maintenance is required, the product needs to be transported to the explosion-proof workshop for repair.**
2. For the faults requiring radical disassembly and bending operation of the heat exchanger, such as the replacement of integral disassembly of the condenser, inspection and maintenance at the user's site are never allowed.
3. For the faults requiring replacement of the compressor or parts & components of refrigeration system, maintenance at the user's site is not allowed.
4. For other faults not involved in the refrigerant container, internal refrigeration pipelines and refrigeration elements, the maintenance at the user's site is allowed, including the cleaning and dredging of the refrigeration system requiring no disassembly of refrigeration elements and no welding.

Qualification Requirements of Maintenance Personnel

1. All the operators or the maintenance personnel involved in refrigerating circuits shall be provided with the effective certificate issued by an industry-accepted assessment institute, to ensure that they are qualified for safety disposal of refrigerant as required in the assessment regulations.
2. The equipment can only be maintained and repaired as per the method recommended by the manufacturer. In case the assistance from personnel of other disciplines is required, the assistance shall be supervised by the personnel with qualification certificate involved in flammable refrigerant.

Inspection on Maintenance Environment

1. Before operation, the refrigerant leaked in the room is not allowed.
2. Continuous ventilation shall be maintained during maintenance.
3. Open fire or high-temperature heat source higher than 548 degree which can easily give birth to open fire is not allowed inside the room within the maintenance area.
4. During maintenance, the phones and the radioactive electronics of all the operators inside the room must be powered off.
5. One dry powder or carbon dioxide extinguisher shall be equipped inside the maintenance area, and the extinguisher must be under available state.

Safety instructions (to be followed at any time)

Maintenance Site Requirements

1. The maintenance site shall be provided with favorable ventilation and **the ground is level**. Arrangement of the maintenance site inside the basement is not allowed.
2. Welding zone and non-welding zone shall be divided at the maintenance site, and shall be clearly marked. A certain safety distance must be guaranteed between the two zones.
3. Ventilators shall be installed at the maintenance site, and exhaust fans, fans, ceiling fans, floor fans and dedicated exhaust duct can be arranged, to meet the requirements of ventilation volume and uniform exhaust, and to avoid accumulation of refrigerant gas.
4. Leak detection equipment for flammable refrigerant shall be equipped, with relevant management system being established. Whether the leak detection equipment is under available state shall be confirmed before maintenance.
5. Sufficient dedicated vacuum pumps of flammable refrigerant and refrigerant charging equipment shall be equipped, with relevant management system for maintenance equipment being established. It shall be guaranteed that the maintenance equipment can only be used for vacuumizing and charging of one type of flammable refrigerant, and mixed usage is not allowed.
6. The master power switch shall be arranged outside the maintenance site, with protective (anti-explosive) device being equipped.
7. Nitrogen cylinders, acetylene cylinders and oxygen cylinders shall be placed separately. The distance between the gas cylinders above and the working area involved in open fire shall be at least 6m. The anti-backfire valve shall be installed for the acetylene cylinders. The color of the acetylene cylinders and oxygen cylinders installed shall meet the international requirements.
8. The warning sign of "No Fire" shall be arranged inside the maintenance area.
9. Fire control device suitable for electric appliance such as the dry powder extinguisher or carbon dioxide extinguisher shall be equipped, and shall always be under the available state.
10. The ventilator and other electrical equipment at the maintenance site shall be relatively fixed, with standardized pipe routing. Temporary wires and sockets at the maintenance site are not allowed.

Leak Detection Methods

1. The environment in which the refrigerant leakage is checked shall be free from potential ignition source. Leak detection with halogen probes (or any other detector with open fire) shall be avoided.
2. For the system containing flammable refrigerant, leak detection may be realized with electronic leak detection equipment. During leak detection, the environment in which the leak detection equipment is calibrated shall be free from refrigerant. It shall be guaranteed that the leak detection equipment will not become potential ignition source, and is applicable to the refrigerant to be detected. Leak detection equipment shall be set at a percentage of the LFL of the refrigerant and shall be calibrated to the refrigerant employed, and the appropriate percentage of gas (25 % maximum) is confirmed.
3. The fluid used for leak detection shall be applicable to most of the refrigerant. The use of chlorine-containing solvent shall be avoided, to avoid chemical reaction between chlorine and refrigerant and corrosion to copper pipelines.

Safety instructions (to be followed at any time)

4. In case leakage is suspected, the open fire at the site shall be evacuated or be put out.
5. In case welding is required at the leakage position, all the refrigerants shall be recovered, or be isolated at a position far from the leak point with a stop valve. Before and during welding, the whole system shall be purified.

Safety Principles

1. During product maintenance, favorable ventilation shall be guaranteed at the maintenance site, and the close of all the doors/windows is not allowed.
2. Operation with open fire is not allowed, including welding and smoking. The use of phones is also not allowed. The user shall be informed that cooking with open fire is not allowed.
3. During maintenance in a dry season, when the relative humidity is less than 40%, anti-static measures shall be taken, including the wearing of cotton clothes and cotton gloves.
4. In case the leakage of flammable refrigerant is identified during maintenance, forced ventilation measures shall be taken immediately, and the source of leak shall be plugged.
5. In case the product damaged must be maintained by disassembling the refrigeration system, the product must be delivered to the maintenance point. Welding of refrigerant pipelines at the user's site is not allowed.
6. The refrigeration system must be safely earthed in the whole course of maintenance.
7. For the door-to-door service with refrigerant cylinders, the refrigerant charged inside the cylinder cannot exceed the specified value. The cylinder placed in vehicles or at the installation/maintenance site shall be fixed perpendicularly and be kept away from heat sources, ignition source, source of radiation and electric appliance.

Refrigerant Charging Procedures

The following requirements are added as the supplementation of conventional procedures:

1. During the use of refrigerant charging tools, cross contamination of different refrigerants shall be avoided. The total length (including the refrigerant pipelines) shall be shortened as much as possible, to reduce the residual of refrigerant inside;
2. The cylinders of refrigerant shall be kept upright;
3. Before refrigerant charging, the refrigeration system shall be earthed;
4. A label must be pasted on the refrigeration system after refrigerant charging;
5. Excessive charging is not allowed; the refrigerant shall be charged slowly;
6. In case system leakage is identified, refrigerant charging is not allowed unless the leak point is plugged;
7. During refrigerant charging, the charging amount shall be measured with an electronic scale or a spring scale. The connecting hose between the refrigerant cylinder and the charging equipment shall be relaxed appropriately, to avoid impact on the measuring accuracy due to stress.

Requirements on storage site of refrigerant:

1. The cylinder of refrigerant shall be placed in a -10-50°C environment with favorable ventilation, and warning labels shall be pasted;
2. The maintenance tool in contact with the refrigerant shall be stored and used separately, and the maintenance tool of different refrigerants cannot be mixed.

Instructions on transportation and storage

1. During transportation or storage, the heat pump water heater shall be packed in the undamaged package to avoid damage to appearance and performance of the product;
2. During transportation or storage, the heat pump water heater shall be in the upright position;
3. Under special conditions, this product may be laid down for a short time/distance as per indication on the side of the package case. The heat pump water heater, after being laid down for a certain time, shall be kept at upright position for more than 4 hours before starting up.



The machine shall be kept in the upright position at any time for the best performance !

Functionings & principles

A low-pressure liquid refrigerant is vaporized in the heat pump's evaporator and passed into the compressor. As the pressure of the refrigerant increases, so does its temperature. The heated refrigerant runs through a condenser coil within the storage tank, transferring heat to the water stored there. As the refrigerant delivers its heat to the water, it cools and condenses, and then passes through an expansion valve where the pressure is reduced and the cycle starts over.

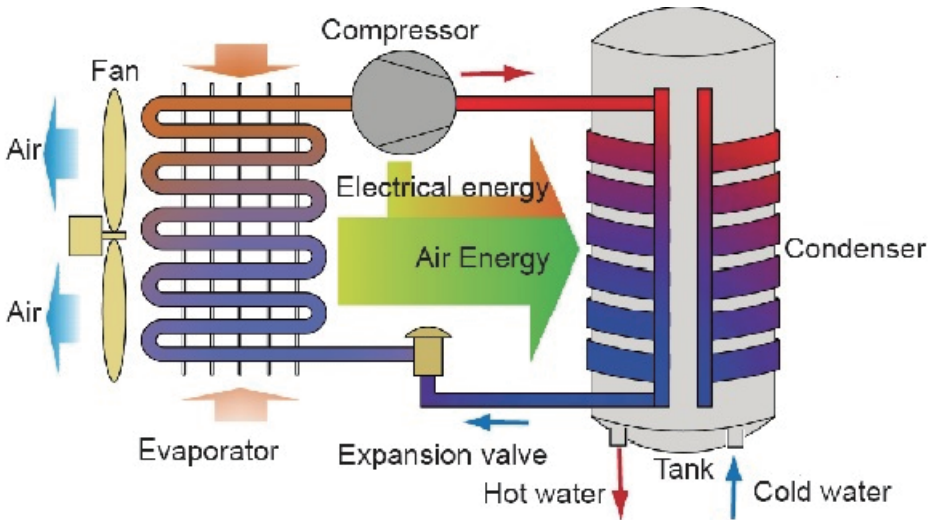

Technical parameters

Model	HP80M8-9/B(GN-K)	HP110M8-9/B(GN-K)	HP150M8-9/B(GN-K)
Tank			
Total cylinder capacity	82L	102L	149L
Rated voltage/frequency	220V~240V/50Hz	220V~240V/50Hz	220V~240V/50Hz
Tank max pressure	0.8MPa	0.8MPa	0.8MPa
Thermal insulation	40mm	40mm	40mm
Corrosion protection	Electronic anode	Electronic anode	Electronic anode
Insulation Protection Rating	IPX4	IPX4	IPX4
Performances			
Type of extraction	Ambient/Exterior	Ambient/Exterior	Ambient/Exterior
COP@2 °C /EN16147(*)	2.35	2.55	3.65
COP@7 °C /EN16147(*)	2.91	2.79	3.03
COP@14 °C /EN16147(*)	3.07	3.32	3.39
Air Flow	180m ³ /h	180m ³ /h	180m ³ /h
Tapping cycle(*)	M	M	L
Power input by electric backup	1200W	1200W	1200W
Rated power input by heat pump	250W	250W	250W
Maximum power input by heat pump	370W	370W	370W
Maximum power input	1570W	1570W	1570W
Standby power input/Pes(*)	15.3W	19.3W	22.5W
Heating up time (7 °C)(*)	4h26	5h38	8h37
Heating up time (14 °C)(*)	3h48	4h47	7h11
Volume of mixed water at 40°C @7 °C(*)	103.8L	133.0L	190.0L
Reference Hot Water Temperature @7 °C(*)	53.75 °C	53.88 °C	52.98 °C
Default temperature setting	56 °C	56 °C	56 °C
Heating temperature range (HP)	35 °C-65 °C	35 °C-65 °C	35 °C-65 °C
Heating temperature range (HP&heater)	35 °C-75 °C	35 °C-75 °C	35 °C-75 °C
Maximum length of air duct	40m	40m	40m
Diameter of air duct connection	160mm	160mm	160mm
Max working pressure of refrigerant	1.0/3.3MPa	1.0/3.3MPa	1.0/3.3MPa
Refrigerant type/weight	R290/0.12kg	R290/0.12kg	R290/0.12kg
Sound power level (**)	50dB(A)	50dB(A)	50dB(A)
Sound Pressure at 1 m	37.7dB(A)	37.7dB(A)	37.7dB(A)
Ambient temperature for use of product	-7 °C-45 °C	-7 °C-45 °C	-7 °C-45 °C
Operating temperature of heat pump	-7 °C-45 °C	-7 °C-45 °C	-7 °C-45 °C
Thermal dispersion [kWh/24h]	0.360	0.456	0.528
Thermal dispersion S [W]	15.3	19.3	22.5
Thermal dispersion Ktank [W/K]	0.33	0.42	0.49
Dimension and connections			
Water inlet and outlet connection	R 1/2" M	R 1/2" M	R 1/2" M
Safety valve connection	R 1/2" M	R 1/2" M	R 1/2" M
Product Dimensions	(492*547*1184)mm	(492*547*1334)mm	(492*547*1694)mm
Packing dimension without pallet	(587*587*1247)mm	(587*587*1397)mm	(587*587*1764)mm
Packing dimension with pallet	/	/	(587*587*1894)mm
Net/Gross weight	51/58kg	54/62kg	64/83kg
(*)According to EN 16147; (**)According to EN 12102; The COP values obtained with external air temperature of 7°C and 14°C, inlet water temperature of 10°C and set temperature of 55°C (HP80M8-9/B(GN-K)&HP110M8-9/B(GN-K), according to EN 16147), inlet water temperature of 10°C and set temperature of 54°C (HP150M8-9/B(GN-K), according to EN 16147). The Sound power level data obtained with external air temperature of 7°C, inlet water temperature of 10°C and set temperature of 55°C, according to EN 12102.			

Description of parts and components

Heat pump structure

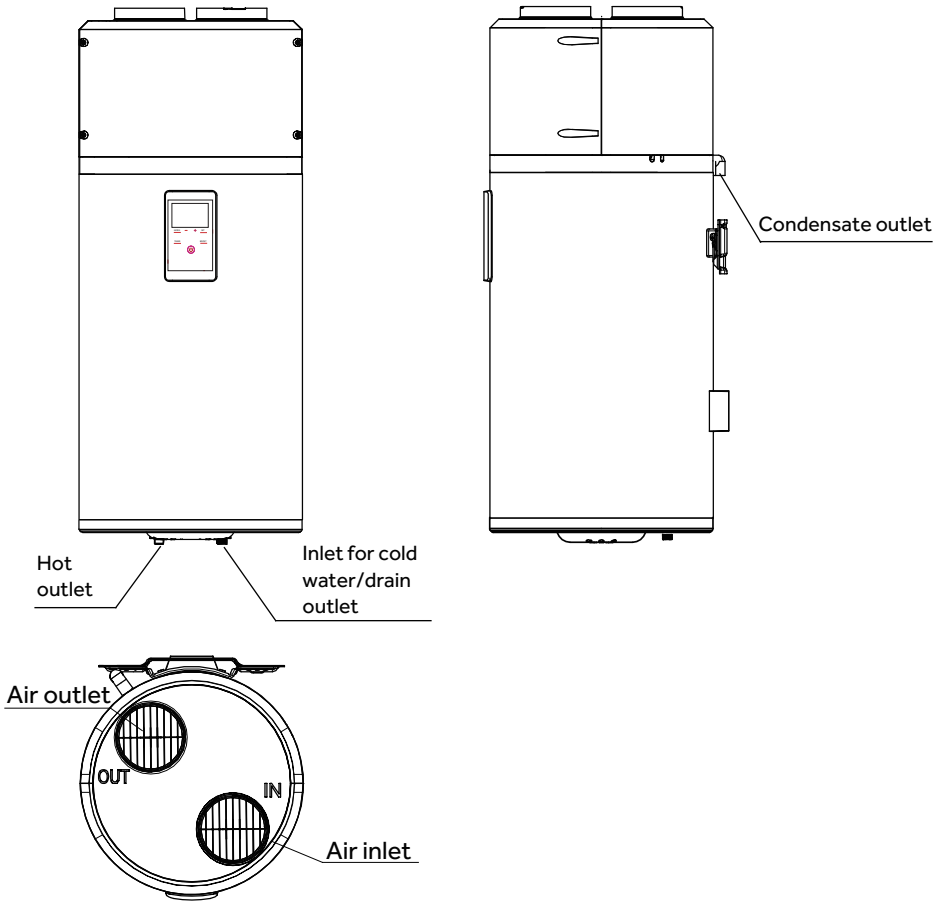

Accessories

Part name	Safety valve	Drainage pipe for condensate water	Support plate	Instruction manual
Quantity	1	1	1(HP80M8-9/B(GN-K)) 1(HP110M8-9/B(GN-K)) 2(HP150M8-9/B(GN-K))	1

Description of parts and components

Exploded view

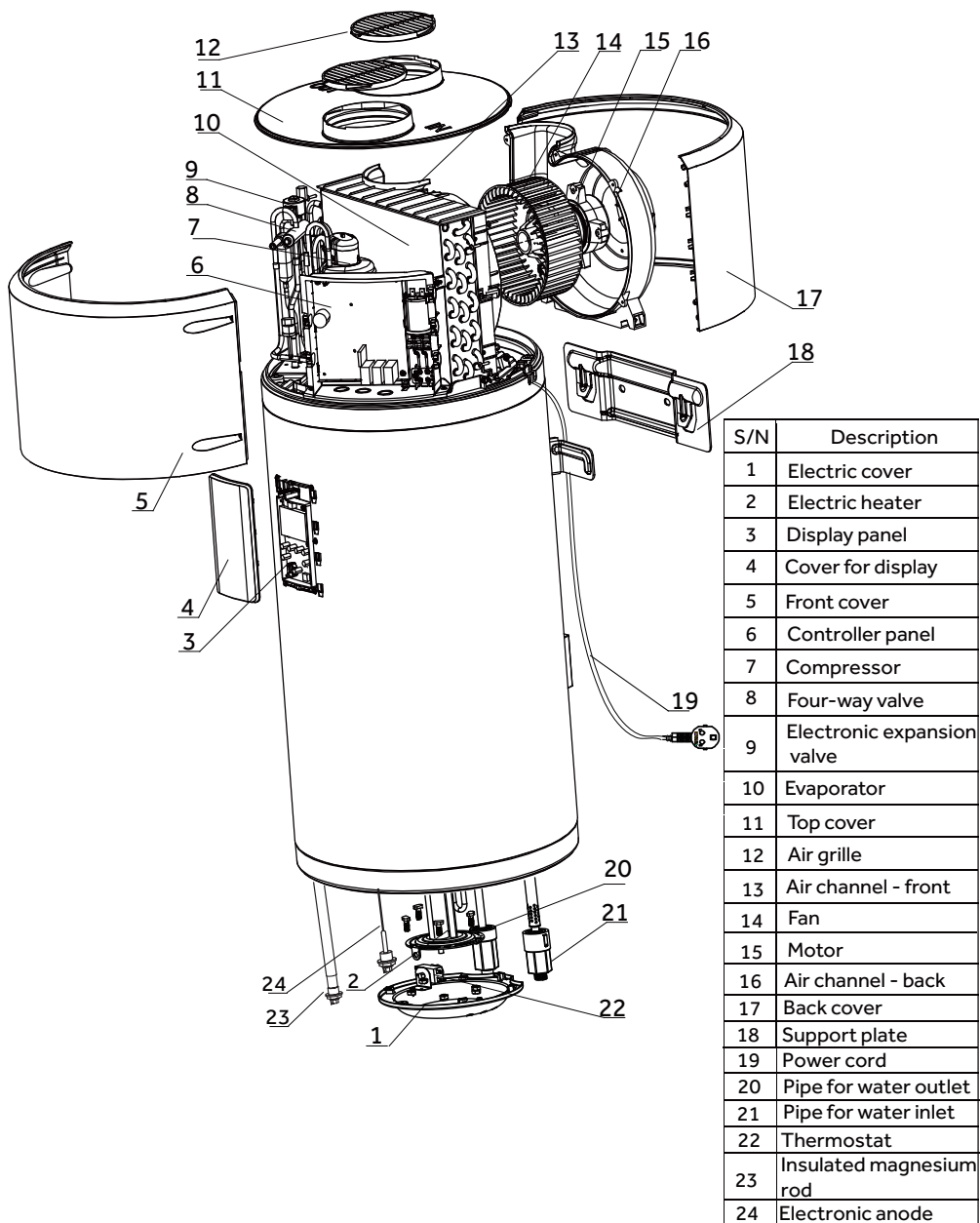

Installation introduction

Installation precaution

- Do not install the water heater in the position where exposed to gas, vapours or dust.
- Install the appliance on a flat, solid surface. The surface can support the machine weight and the condensate water can be drained freely.
- Noise due to operating and air flow do not bother neighbors.
- Make sure there is sufficient space left for installation and maintenance.
- There is no strong electromagnetic interference around that may affect control functions.
- There is no sulfur gas or mineral oil existing at the installation place, which may cause corrosion of the machine and the fittings.
- The water pipe for the water heater used at temperatures below 0°C shall not freeze.
- It shall not be set in rooms where a heating system is used so that heating supply to the room will not be affected.
- It shall not be set inside a totally-enclosed space.
- The air taken in must in no event be dusty.
- Install the appliance in a dry, frost-free room.
- Temperature of the ambient air or of the air taken in by the heat pump for optimum running: from 2°C to 35°C.

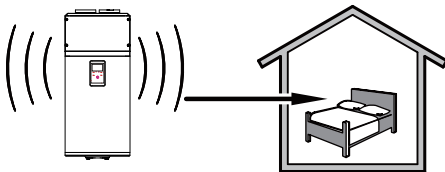

 Keep an adequate distance between the working heat pump and the resting room.

Installation introduction

Installation dimensions

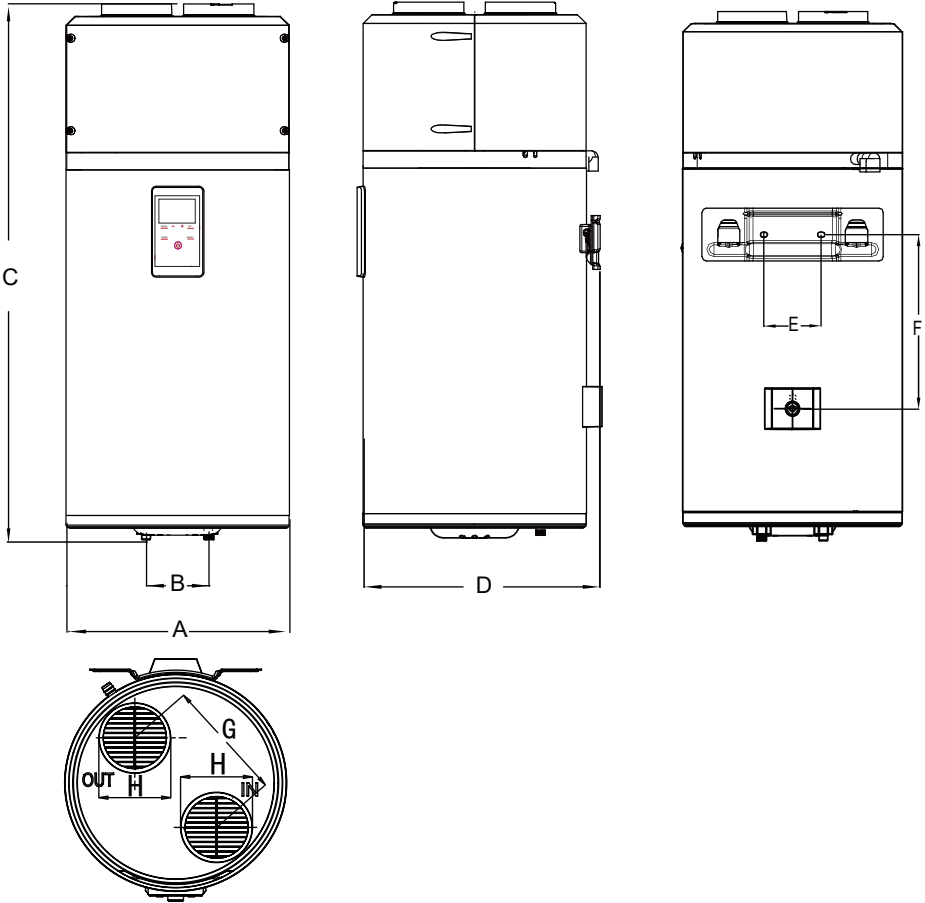

Unit:mm

Model	A	B	C	D	E	F	G	H
HP80M8-9/B(GN-K)	492	140	1184	547	159	360	272	160
HP110M8-9/B(GN-K)	492	140	1334	547	159	510	272	160

Installation introduction

Installation dimensions

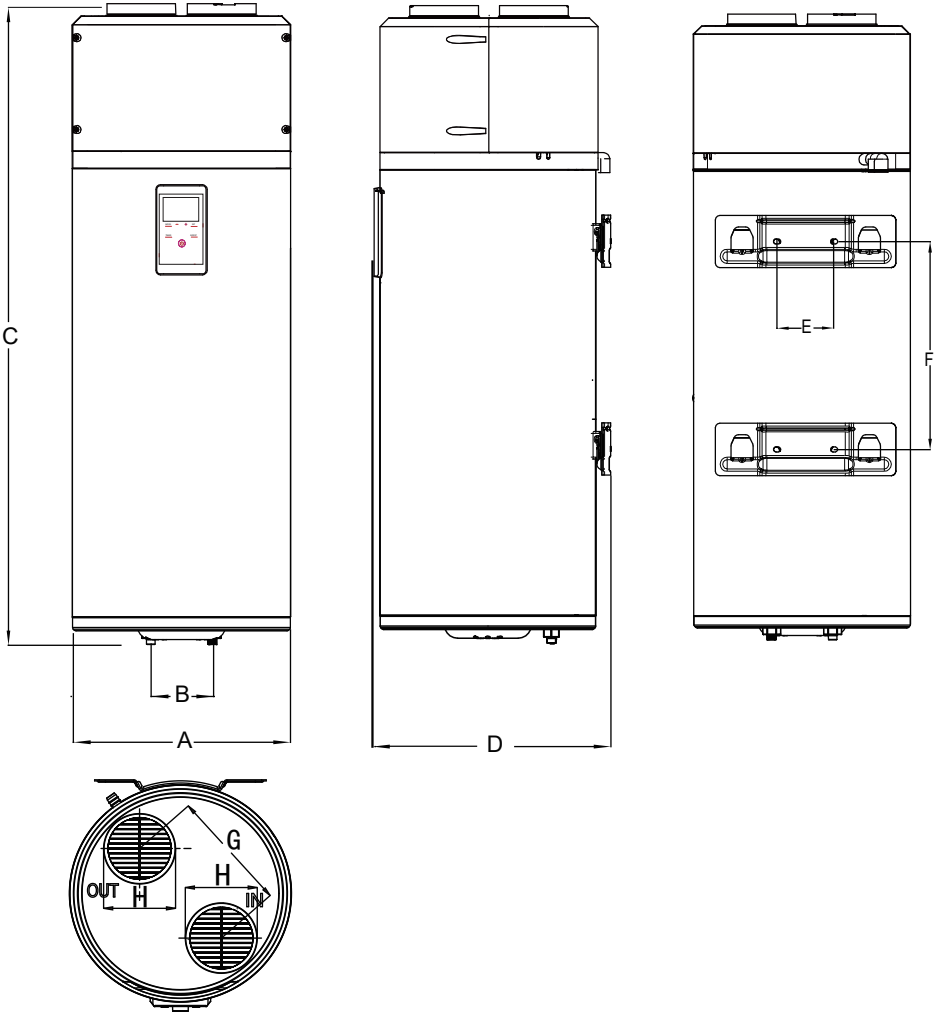

Unit:mm

Model	A	B	C	D	E	F	G	H
HP150M8-9/B(GN-K)	492	140	1694	547	159	470	272	160

Installation introduction

Installation dimensions

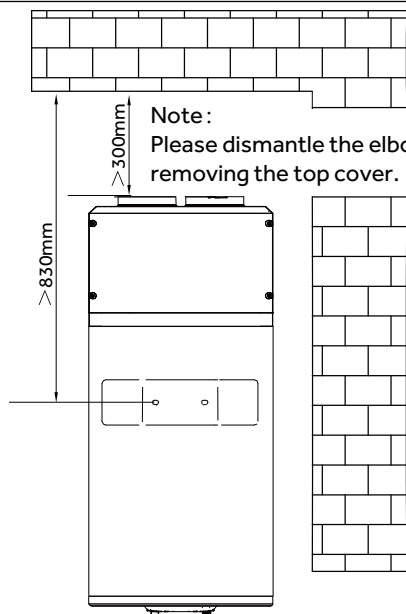

Note: These two expansion bolts can support 200kg weight at least. Please use the expansion bolts adapted to your wall material.

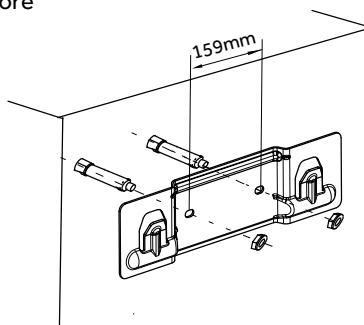

Installation angle refer to the following diagrams:

After the installation is completed, it is necessary to use a level ruler to check whether the support is maintained in a horizontal state.

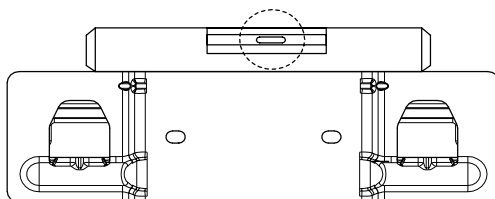
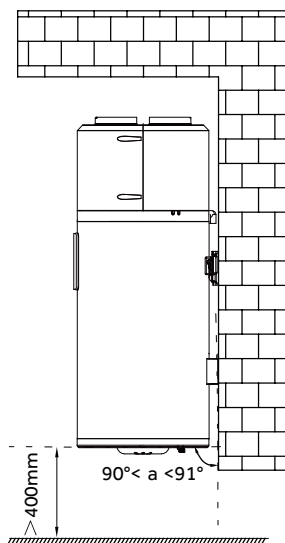

Note:

Please leave sufficient distance for easy disassembly of the **electronic anode** and electric auxiliary heater.

Installation introduction

Installation dimensions

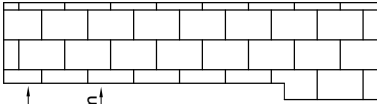

Note: These two expansion bolts can support 250kg weight at least . Please use the expansion bolts adapted to your wall material.

Note:
Please dismantle the elbows
before removing the top cover.

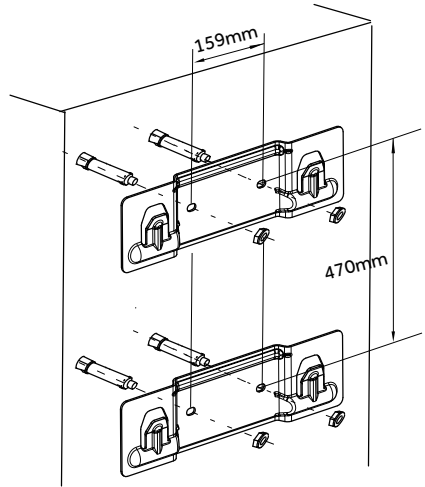
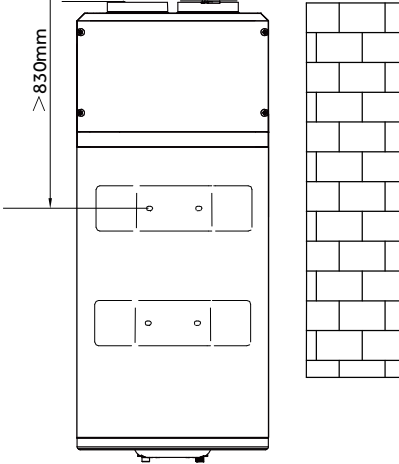

Installation angle refer to the following diagrams :

After the installation is completed, it is necessary to use a level ruler to check whether the support is maintained in a horizontal state.

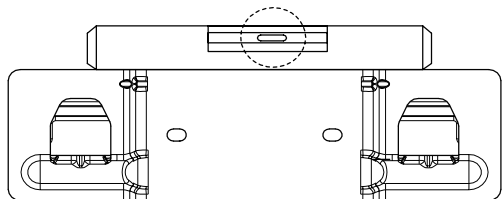
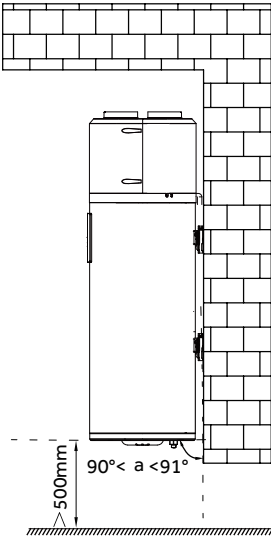

Note:

Please leave sufficient distance for easy disassembly of the **electronic anode** and electric auxiliary heater.

Installation introduction

Air connection

- Remove air grille first.

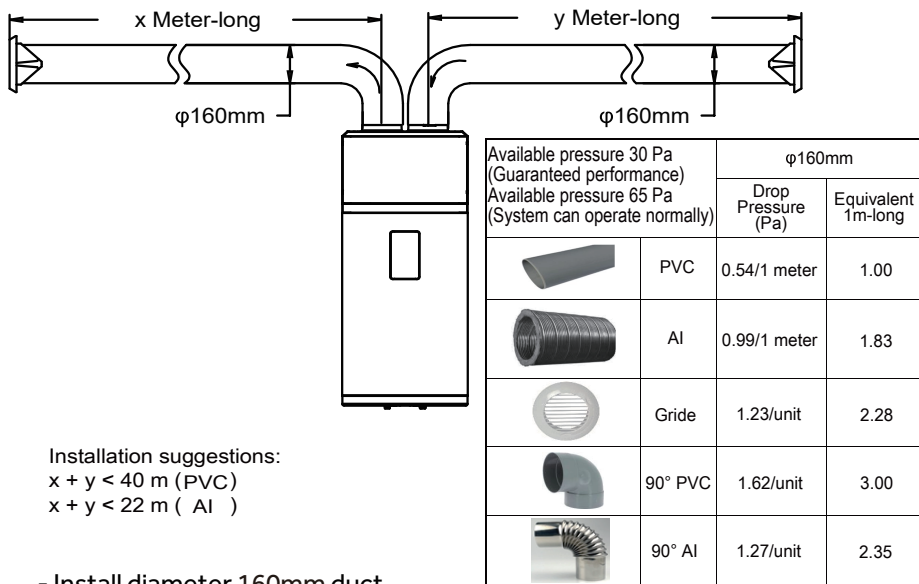
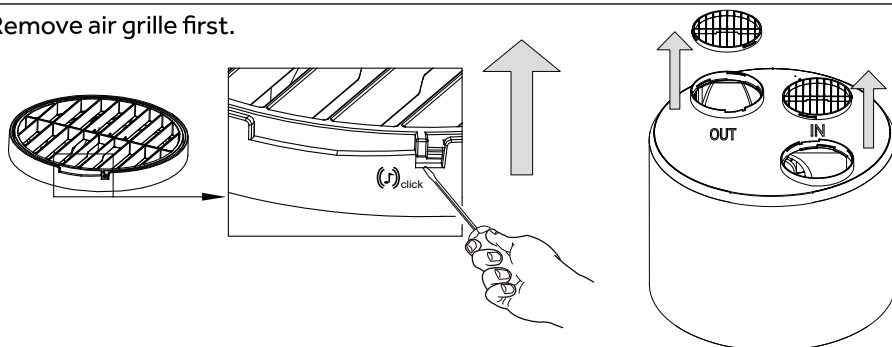

Installation suggestions:

$x + y < 40$ m (PVC)

$x + y < 22$ m (Al)

- Install diameter 160mm duct.
- Pressure drops from duct must be lower than or equal to the static pressure of the fan.
- If the pressure drops out of range, the performance of the appliance will be impaired.

In order to ensure the performance of the product, it is recommended that the total length of the air duct should not exceed 22m(Bellows tube) and 40 m (Smooth tube). In this case, the performance will not be guaranteed.

It is recommended that an air grille with a mosquito net be installed at the air inlet of the air guide duct. **The ventilation area shall not be less than 180 cm².**

Installation introduction

Advised positions

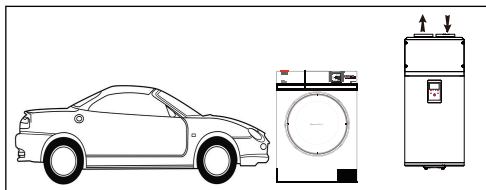

Garage or laundry room (without ducts):

- Unheated room.
- Enables recovery of the free energy released by your vehicle's engine when switched off after use or by household appliances in operation.
- The room volume shall not be less than 15m³ and shall be maintained in a ventilated state.

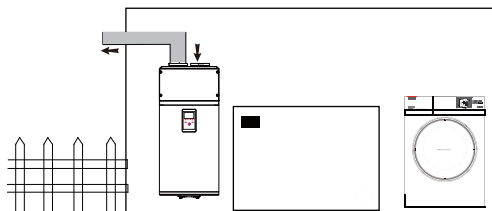

Laundry room (with one duct):

- Unheated room.
- Enables recovery of the free energy released by your vehicle's engine when switched off after use or by household appliances in operation.
- The room volume shall not be less than 15m³ and shall be maintained in a ventilated state.

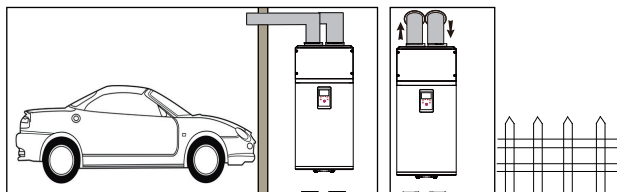

Habitable room or outside air (with two ducts):

- Can obtain free heat from the garage.
- If the outside air temperature is too low, connection to the outside air may lead to overconsumption of electricity.
- Referring installer menu , adjust the fan speed.
- Avoid refreshing heated room.

Installation introduction

Installation caution



When making the connections, you should respect the standards and local directives.

- Before making the connection, rinse the water inlet pipes, in order not to introduce metal or other particles into the tank.
- Select copper pipes for pipeline connection.
- The inlet water pressure is between (0.1-0.5)MPa. If lower than 0.1 MPa, a booster pump shall be added at the water inlet; if higher than 0.5 MPa, a pressure relief valve shall be added at the water inlet.
- The inlet water temperature is suggested between (10-30)°C.
- Outdoor water pipeline and valves should be proper insulated.
- In accordance with safety rules, a safety valve(0.8MPa ,R1/2F) must be installed on the tank.For France, we recommend hydraulic safety units fitted with a membrane with the NF marking.
Integrate the safety valve in the cold water circuit.Install the safety valve close to the tank in a place which is easy to access.
No isolating devices should be located between the safety valve or unit and the tank.
The rated pressure of the safety valve shall not exceed 0.8MPa.
- Never block the outlet of the safety valve or its drain line for any reason.
- The diameter of the safety unit and its connection must be atleast equal to the diameter of the domestic cold water inlet.
- If the mains pressure exceeds 80% of safety valve, a pressure reducer must be installed upstream of the appliance.
- NOTE: Don't install and use the product outdoors.



If the air inlet and outlet of the product are not installed with air ducts, the air inlet and outlet of the product shall be protected to prevent water inflow, and the waterproof measures shall reach IPX4 level.

Installation introduction

Pipeline installation diagram

Installation A

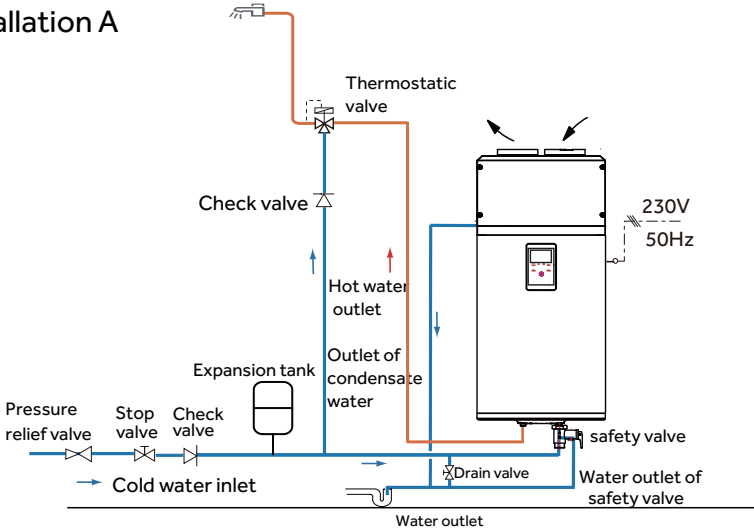

Installation B (for France only)

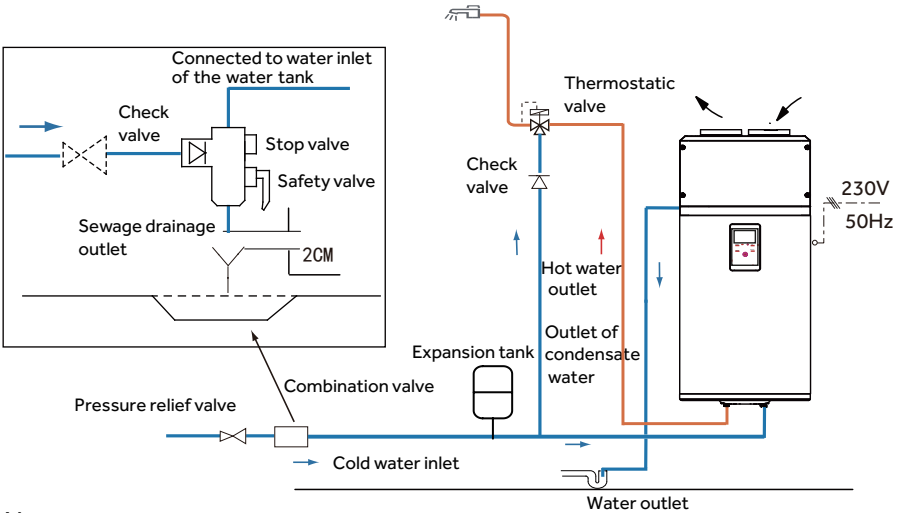

Note:

- Pressure relief valve, thermostatic valve, stop valve, check valve, expansion tank and combination valve are not included in the accessories, please select proper fittings in local market;
- Valves with NF/CE certification are recommended ;

Installation introduction

Electrical connections precautions



WARNING

- Only qualified professionals may carry out electrical connections, always with the power off.
- The earthing shall comply with local standards.

- Water heaters shall be equipped with a dedicated power line and residual current circuit breakers. The action current shall not exceed 30 mA;
- The ground line and the null line of the power supply shall be separated entirely. Connecting the null line to the ground line is not allowed.
- Parameter of the power line: $3 \times 1.5 \text{ mm}^2$ or more.
- If a power cable is damaged, it shall be replaced by qualified professionals to avoid risks.
- In the case of places and walls where water may be splashed to, installation height of a power socket shall not be less than 1.8 m, and it shall be ensured that water would not be splashed on these places. The socket shall be installed out of children's reach.
- The phase line, zero line and ground line inside a power socket used in your home shall be wired correctly without any wrong positioning or false connection, and internal short circuit shall be avoided. Wrong wiring may cause fire accidents.

Connection to a PV system

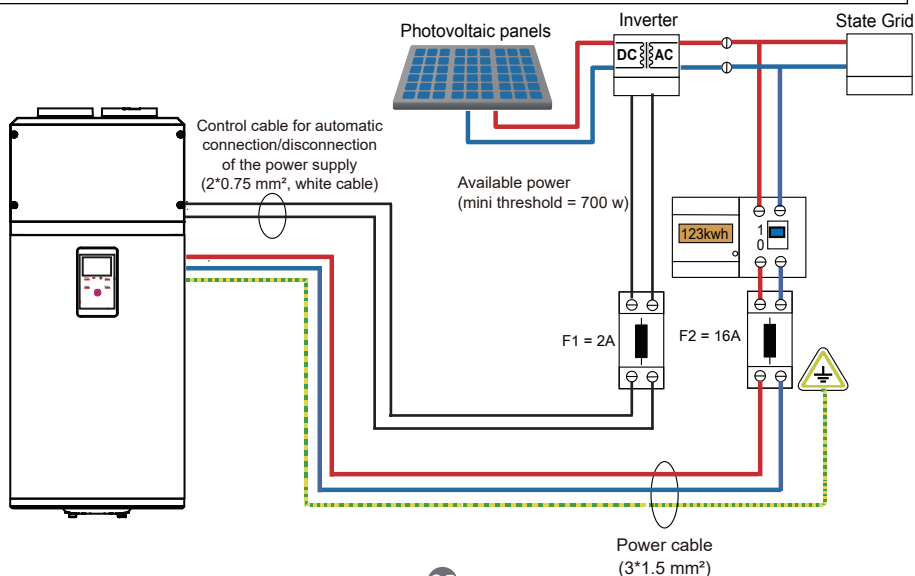

Installation introduction

HC/HP power signal wire connection

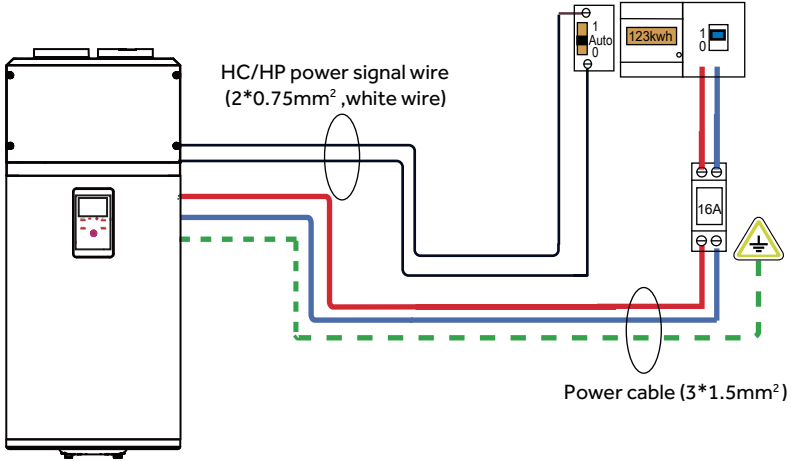

SG signal wire connection

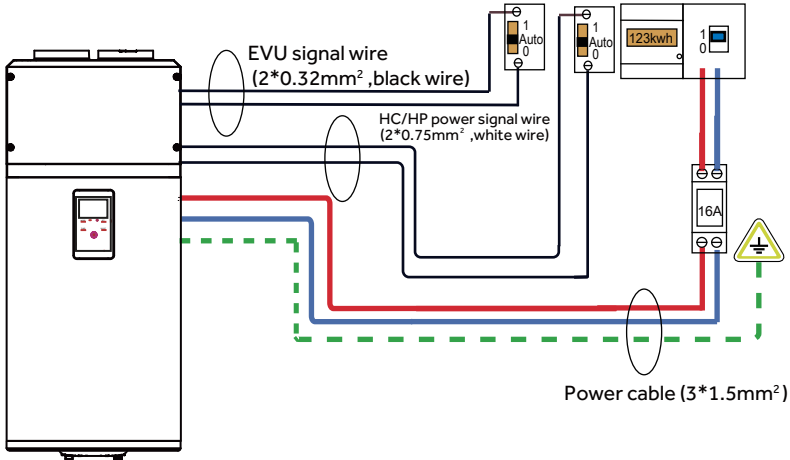

Installation introduction

Wiring diagram

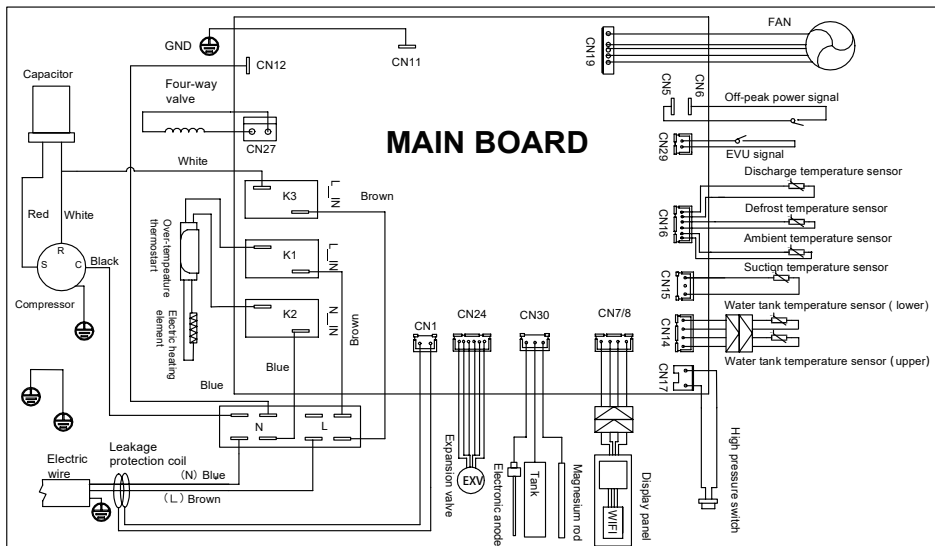

Commissioning

Installers shall use checking list for trial operation of water heaters as per the user manual and make ✓ in □.

- Electrical wires are fixed securely?
- Water drain pipes are connected correctly?
- Ground wires are connected securely?
- Supply voltage conforms to relevant electric codes?
- The control panel works well?
- All noises are normal?
- The water tank has been connected with dedicated pressure relief valve (TP valve) and check valve?
- Materials for hot/cold water pipes conform to requirements of use of hot/cold water?
- After the water system is completed, the water tank is filled with water? Is there water drained out of the water outlet of the hot water pipeline?
- After the water pipe of the water system is filled, check the whole water pipeline. There is no leakage?
- After the water system is filled with water, is there water flowing out after pressure is relieved via the automatic safe pressure relief valve?
- After the water system is filled with water and after leakage check, all outdoor water pipelines are applied with heat insulation treatment?
- The drain valve, drain pipe and pressure relief valve drain pipe of the water tank have been connected to the sewage system and the drainage can be carried out well?

Operation and functions

Display

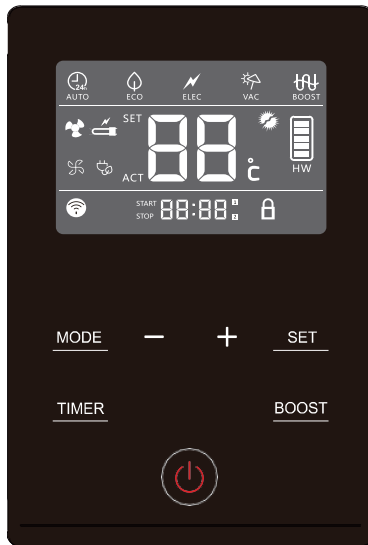

Functions & Protections

A. Electrical leakage protection

The control system of this machine features an electricity leakage protection function.

B. 3-minutes protection

When starting the machine after electricity input, the system will start after approximately 3 minutes, which is considered to be normal.

When restarting the machine immediately after shutdown, the system goes into the protection mode and starts after approximately 3 minutes, which is considered to be normal.

C. Automatic defrosting function

The defrosting mode is automatically activated if the outdoor temperature is too low and after the compressor already runs continuously for a certain period.

D. Overload protection









The working load of the compressor will be heavy if temperature is high in summer. In order to meet hot water requirements of users and to lengthen service life of the compressor, this product automatically adjusts the fan speed to ensure reliable operation of the compressor.

E. Anti-freezing function









The heat pump starts heating to avoid freezing of the water tank if the temperature in the water tank is too low.

F. The default temperature setting is 56°C.

Description of the icons

Symbol	Description
	Power ON/OFF switch
	Working mode selection
	Confirm button
	Press the TIMER button to adjust the value in the order of hour, minute, week, day, month, and year. All data must be set at one time, and exit in the middle is invalid.
	Boost mode. Heat pump and auxiliary power are activated at the same time.
	<p><u>Auto mode</u></p> <ul style="list-style-type: none"> - Optimised management of the heat pump and the electrics for guaranteed comfort; - Prior using heat pump; - If compressor works more than the default 12 hours , start the auxiliary power; - The compressor maximum continuous working time (\overline{AA}) can be adjust in the installer settings.
	<p><u>ECO (off-peak) mode</u></p> <ul style="list-style-type: none"> - In this mode, priority using heat pump, refer to Installer setting for details; - the user can set the off-peak period and does not work outside the off-peak period. - After entering the ECO mode, press SET to enter the four time ranges. The L1 and L2 time ranges are valid from Monday to Friday, and the L3 and L4 time ranges are valid from Saturday to Sunday. The start time and end time must be different; otherwise, the setting is invalid.
	<p><u>Electric heating mode</u></p> <ul style="list-style-type: none"> - In this mode, the electric heating function is turned on, and the electric heating function remains effective. - This function ensures hot water supply when the heat pump is not working properly.
	<p><u>Holiday mode</u></p> <ul style="list-style-type: none"> - According to the vacation dates in advance to prepare hot water; - In VAC mode, the number of vacation days should be set first. The range of vacation days is 1 to 99 days. For example, you leave home for vacation on 1st January and return home on 5th January, the number of vacation days should be set to $5-1=4$ days. - The day before the end of the holiday, the unit starts heating according to the sterilization start time and sterilization target temperature set in the installation Settings. - After the heating is completed, the unit returns to AUTO mode at 0:00 on the day of the end of the holiday.

Function Introduction

Symbol	Description
	BOOST mode. Heat pump and backup element are activated at the same time under AUTO/ECO .Only backup element are activated in VAC mode and ELEC mode.The Boost function works once. BOOST mode has the highest priority and can be started in any mode.
	Heat pump working icon.
	Auxiliary electrical heater working icon.
	When the PV/HC/SG signal is active, the light will be lit, and the unit will operate according to the function parameters set in the Installer settings (P32) operation.
	<p><u>Sterilization</u></p> <ul style="list-style-type: none"> - The unit will be heated at intervals according to the set sterilization interval, sterilization start time and sterilization target temperature to achieve the purpose of killing Legionella bacteria in the tank. -Sterilization switch, sterilization target temperature, sterilization interval and sterilization start time can be performed through the display board installation setting menu. -During the sterilization process, the user manually operates (switching mode, Switch on and off, outage) to exit the sterilization function. - If the sterilization interval is selected to be executed only once, it will be executed at the set time of the next day, after the sterilization heating is completed, the sterilization will be withdrawn and the sterilization function will be automatically turned off. No sterilization during VAC mode.
	Hot water volume display.
	WiFi signal icon.
	<p><u>Lock screen display icon</u></p> <ol style="list-style-type: none"> 1. Enter: In the power-on state, press and hold TIMER+BOOST (combination key) for 6s at the same time, the lock sign will be on, and the screen lock mode will be turned on. 2. After the screen lock mode is turned on, the device will not respond when the user touches any key. 3. Exit: press and hold TIMER+BOOST (combination key) for 6s at the same time, the lock sign is closed, and the screen lock mode is exited.

Function Introduction

Symbol	Description
	Fan speed function, When the Fan speed function is enabled, the light will be lit, and the unit will operate according to the function parameters set in the Installer settings (P33) operation.
Modbus function	MODBUS function setting In the case of shut down, hold down the "+" key for 5s, the slave address is set, The Ad is displayed on the double 8 on the top of the display board, The first digit of small four 8 below the display board is not displayed, and the last three digits display the current address value. From left to right are hundreds, tens, ones, Set in sequence. Slave address Settings range from 1 to 254. The default value is 001.

Note: Under certain conditions, ECO mode may result in shortages of hot water if the ambient air temperature is low.

Energy accumulation and energy consumption query

1. Press the "+" and "SET" keys at the same time for 5 seconds when the unit is turned on, and the buzzer will sound once to enter the energy accumulation and energy consumption interface, on the display, dual 8-digit tube displays the cumulant code, and the four 8-digit tube displays the cumulant data (which is rounded down), press the "+" or "-" key to switch between pages, the meanings of different pages are as follows:

- A1: Accumulated heat for nearly a month
- A2: Accumulated heat for nearly a year
- C1: Compressor cumulative power consumption for nearly a month
- C2: Compressor cumulative power consumption for nearly a year
- E1: Element cumulative power consumption for nearly a month
- E2: Element cumulative power consumption for nearly a year





2. If 20 seconds no operation or press the switch to exit, return to the main interface.

3. Energy unit: kWh

4. After entering the energy accumulation & energy consumption query interface, continue to press the "+" and "SET" keys for 5 seconds, all data is cleared, the four 8-digit tube displays 0, and the data starts to accumulate again.

Function Introduction

Installer settings

- To open the installer settings, press  switch off the system, then press  and **SET** at the same time for 5 seconds.
- When menu is open, press  or  to change the value of the settings.
- Press **SET** to confirm the settings.
- Press  to close the menu.

Parameters	Description	Factory setting	Adjustment range
LP 01, 02 03, 04	<u>Off-peak logic type</u> - In four ways using heat pump, should set in the installer settings -01 Disable function; -02 switch signals by power companies. -03 PV signal. -04 SG signal.	01	01, 02 03, 04
LL NO, NC	<u>Off-peak signal type</u> When you use off-peak time clock control, first determine the type of signals, Only allow professional installers to operate. -NO corresponds to normally open signal, closed effective -NC corresponds to normally closed signal, open effective - If LP is set to 04, LL can only be set to NO .	NO	NO, NC
LA 01, 02	<u>Heating method</u> -01: When there is a signal, immediately change the target temperature to set the temperature corresponding to the trough signal, heating according to the initial or thermal insulation heating starting condition, when there is no signal, execute the current setting mode heating logic. -02: When there is a signal, change the target temperature only within the heating time of the current setting mode, and determine the heating condition (if the current setting mode is set to ECO mode for timed heating, the signal comes during the non-heating period, the target temperature does not jump, and the device does not heat) to determine whether there is no heating signal, and execute the heating logic of the current setting mode. - This parameter is valid only when the LP value is not 01 .If LP is set to 04, LA can only be set to 01.	01	01, 02
Lb 55-75	<u>Target temperature when PV/SG/HC signal is active</u> - The temperature setting is adjustable between 55°C and 75°C. - This parameter is valid only when the LP value is not 01 .If LP is set to 04, LA can only be set to 01.	65	55-75
LC 01, 02 03	<u>Heat source selection in PV/SG/HC function</u> -01 Compressor and electric heating work at the same time. -02 The compressor shall be started first. When the system does not meet the operating conditions, the electric heating can be started. -03 Only electric heating is operated. - This parameter is valid only when the LP value is not 01 .If LP is set to 04, LA can only be set to 01.	02	01, 02, 03

Installer settings

Parameters	Description	Factory setting	Adjustment range
AL ON, OFF	<u>Sterilize</u> - This parameter is the switch of sterilization function. - Every once in a while, heat all domestic hot water to 60° C-75 ° C.	ON	ON, OFF
Ah 60-75	<u>The sterilization target temperature</u> - The sterilization target temperature can be adjusted between 60° C and 75 ° C.	65	60-75
Ad 07, 30 ONCE	<u>Sterilization interval</u> - Sterilization interval can be 7 days, 30 days, only once effective, choose one of the three 07,30,once.	07	07,30, ONCE
AL 00-23	<u>Start time of sterilization</u> - Start sterilization at the set time, only hours can be set.	00:00	00:00-23:00
AA 5-15	<u>Compressor maximum continuous working time</u> - If the maximum continuous working time of the compressor more than Set Time, start auxiliary power	12	5-15
bL 5-15	<u>Average water temperature starting return difference</u> - When the actual average water temperature is 10°C lower than the set temperature, the heat pump will start again, and the adjustment range is 5° C-15 ° C.	10	5-15
bU 5-15	<u>Upper water temperature starting return difference</u> - When the actual upper water temperature is 5°C lower than the set temperature, the heat pump will start again, and the adjustment range is 5° C-15 ° C.	5	5-15
FS 00, 01 02	<u>Fan speed function</u> - When the unit is connected with a long air duct resulting in insufficient air volume, the function is used according to actual needs. -00: Disable function -01: V1 gear (fan speed 750 RPM) -02: V2 gear (fan speed 800 RPM)	00	00,01,02

Installer settings & WIFI connection

WIFI connection

Your appliance can be connected to your home wireless network and operated remotely using the app. Getting started:

1. Search for "Smart App" in the app store, download and install it on your phone.
2. Register an account and log in.
3. Ensure your home Wi-Fi network is turned on and that the device is powered on.
4. Turn off the device, then press and hold the "⏻" button to enter the distribution network status.

At this point, the Wi-Fi icon will start flashing.

5. Open the app and click "Add Device" in the upper right corner. Add the device through either autodiscovery or by scanning the QR code below. If the connection is successful, the Wi-Fi icon will remain solid.



Step1

Download the "Smart Life" App on the stores, search "Smart Life" App.



Step2 Create your account on the "Smart Life" App or log in if you already have an account.

The screenshot shows the 'Register' screen of the Smart Life app. It features a dropdown menu for 'United Kingdom', an input field for 'Email Address', and a 'Get Verification Code' button. At the bottom, there is a checkbox for 'I Agree User Agreement and Privacy Policy'.

1. When the download is finished, click 'Create New Account'.
2. Enter your email address and press 'Get Code'.
3. You will receive an email with a verification code (if it doesn't appear in your inbox, check your spam/junk folder).
4. Set your password and click 'Done' to finish.

Checking and maintenance



- Installation and maintenance of the appliance must be done by a qualified professional .
- Before working on the appliance, Shut down the machine and cut off the power supply .
- Do not touch with wet hands.
- Maintenance operations are important to guarantee optimum performance and extend the life of the equipment.

Checking of the Safety valve

- Operate the safety valve at least once every six months to check if it is running correctly. Otherwise check for blocking and replace the safety valve if necessary.

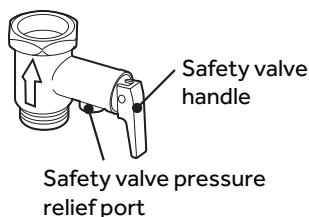

Checking of the hydraulic circuit

- Check the watertightness of the water connections.

Top Cover Removal

- Remove the screw in the left with a screwdriver;
- Rotate the top cover counterclockwise until you can take it off.

Checking of the main control board

- Use a screwdriver to remove the screw.

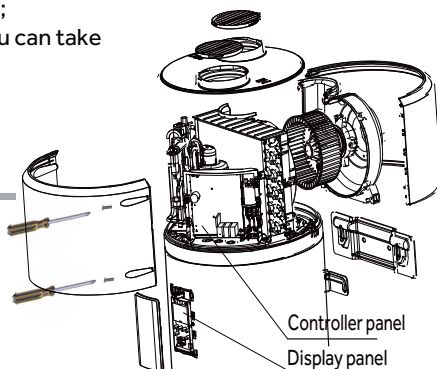

Checking and maintenance

Cleaning of the fan

- Check the cleanliness of the fan one time per year.

Checking of the evaporator



- Because the evaporator fins is very sharp. Risk of injury on your finger.
- Do not damage the fins. Avoid affecting the performance.
- Clean the evaporator at regular intervals using a soft-haired brush.
- If they are bent. Carefully realign the evaporator using a suitable comb.

Checking of the condensates discharge pipe

- Check the pipe cleanliness .
- An obstruction by dust may cause poor condensates flow or even a risk accumulation of water in the heat pump plastic base.

Drain the water tank to empty

- Cut off power supply and shut down water inlet valve, then drain the water tank to empty via the cold water inlet. Please stay away from the cold water inlet if there is hot water inside the water tank to avoid injury.

Faults and protection

Fault type	Action	Digital indication	Release
Communication fault	Communication failure between Wi-Fi module and control board	F0	After fault is solved, switch on power supply for release
Compressor protection	Operating temperature protection	F2	
	Air exhaust temperature protection	F3	
Electricity leakage alarming	The system will automatically cut off power supply if any line fault occurs	E1	After fault is solved, switch on power supply for release
Over temperature alarming	The actual water temperature $\geq 88^{\circ}\text{C}$	E2	
Fault of the inner temperature sensor	If short circuit or circuit break occurs to the sensor	E3	
Fault of the ambient temperature sensor	If short circuit or circuit break occurs to the sensor	E4	
Fault of the evaporation temperature sensor	If short circuit or circuit break occurs to the sensor	E5	
Fault of the air exhaust temperature sensor	If short circuit or circuit break occurs to the sensor	E6	
Fault of the air intake temperature sensor	If short circuit or circuit break occurs to the sensor	Ed	
Communication fault	Communication of main control panel and display panel is abnormal	E7	
Pressure switch protection	Action of the pressure switch at the exhaust outlet	E8	
Ambient temperature protection	Ambient or outdoor temperature $< -7^{\circ}\text{C}$ or $> 45^{\circ}\text{C}$	E9	
Fault of the Off-peak power switching signal	If not received the Off-peak signal when selecting switch signals by power companies	EF	
Fault of the fan	Fan blade is stuck or fan and control panel communication failure	L7	
Fault of Electronic anode	Failure of electronic anode protection due to damage to the control board or water tank.	LE	
Fault of Electronic anode	Electronic anode overcurrent or short circuit failure	LF	
Fault of Electronic anode	The water tank is short of water or the electronic anode is disconnected	Ld	

-The user should ensure that the water tank is full of water before powering the unit.

-In the event of LE or LF failure, the tank anode protection will switch from the electronic anode to the magnesium rod. If the user still wants to use the electronic anode protection tank, please contact the after-sales to troubleshoot the relevant problems. If the user wants to use the magnesium rod to protect the water tank, you can press the switch button to temporarily eliminate the fault (72 hours later, the unit will redetect the electronic anode, if the fault still exists, it will continue to report the fault), you can also press the switch button for 5 seconds to permanently eliminate the fault, but if the power is re-powered, the unit will re-detect whether the electronic anode is normal

- If an Ld fault occurs, the user needs to confirm whether the water tank lacks water or leaks water.

If there are such phenomena, please contact the after-sales service for troubleshooting.

Product Fiche

Model		HP80M8-9/B(GN-K)	HP110M8-9/B(GN-K)	HP150M8-9/B(GN-K)
Power supply	Ph/V/Hz	AC220-240V, 50Hz	AC220-240V, 50Hz	AC220-240V, 50Hz
The water heating energy efficiency (η_{wh})	%	121.9	117.5	125.0
Water heating energy efficiency class	-	Class A+	Class A+	Class A+
Annual energy consumption (AEC)	kWh/annum	423	437	817
The daily electricity consumption (Qelec)	kWh	2.008	2.094	3.850
The sound power level (indoors)	dB(A)	50	50	50
Mixed water at 40 °C	L	103.8	133.0	190.0
Load profiles of water heaters, Type	-	M	M	L
Manufacturer	Qingdao Economic & Technology Development Zone Haier Water-Heater Co.,Ltd.			
Address	Haier Industry Park, Economic & Technology Development Zone, 266101 Qingdao, PEOPLE'S REPUBLIC OF CHINA			
Denomination	Heat pump water heater			
Intended use	Hot water			
Assembly type	single package			
Refrigerant	R290 /120g			

Length of warranty:

- Guarantee of the watertightness of the tank: 5 years
- Electrical System (Electronic and Heat Pump): 2 years

Replacement of a component or product can not in any case extend the initial warranty period.



The  symbol on the product or on its packaging indicates that this product is not to be treated as regular household waste. Instead, it must be taken to a recycling collection point for electrical and electronic equipment. By properly disposing of this product, you are contributing to the preservation of the environment and the wellbeing of your fellow citizens. Improper disposal is hazardous to health and environment. You can obtain further information on how to recycle this product from your municipality, your waste management service or the shop where you purchased it.



powered by **Haier**