

DA-9/7 4P 3V 373W



Dimensiones y conexiones Dimensions and wiring

Características Characteristics

Tensión Voltage	Monofásica 230V 50Hz Single-phase 230V 50Hz
Tipo motor Motor type	3V IP20 cl.F 3S
Velocidad Speed	4 polos 4 poles
Potencia motor Motor power	373 W
Intensidad absorbida máxima Maximum absorbed current	2,7 A
Condensador Capacitor	16 F/450V
Temperatura del aire Air temperature	-20°C < T < +40°C
Peso Weight	11,5 kg
Código ventilador Fan code number	V710033 5128175600 (MP)
Código motor Motor code number	9073005400

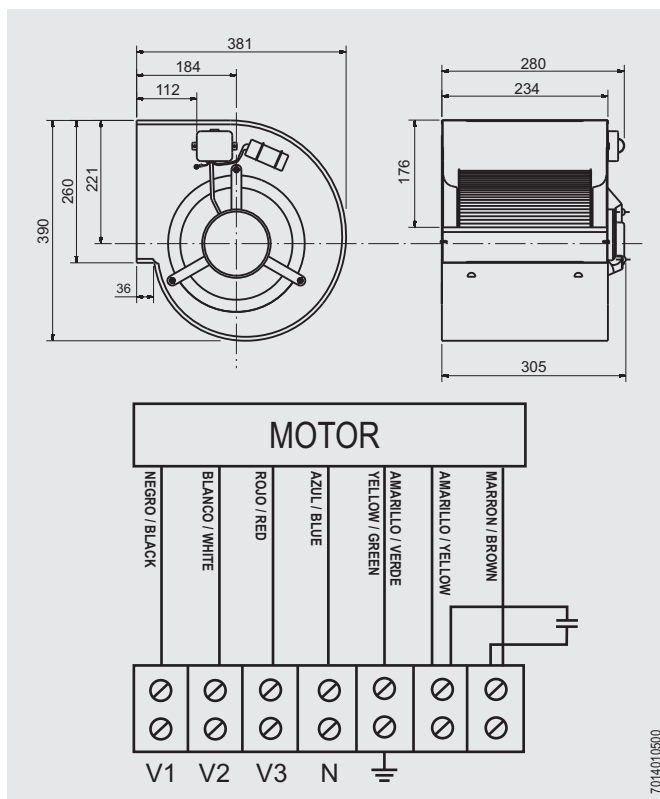

Curvas características / Performance curves (20/03/2009)

