

Montage handleiding

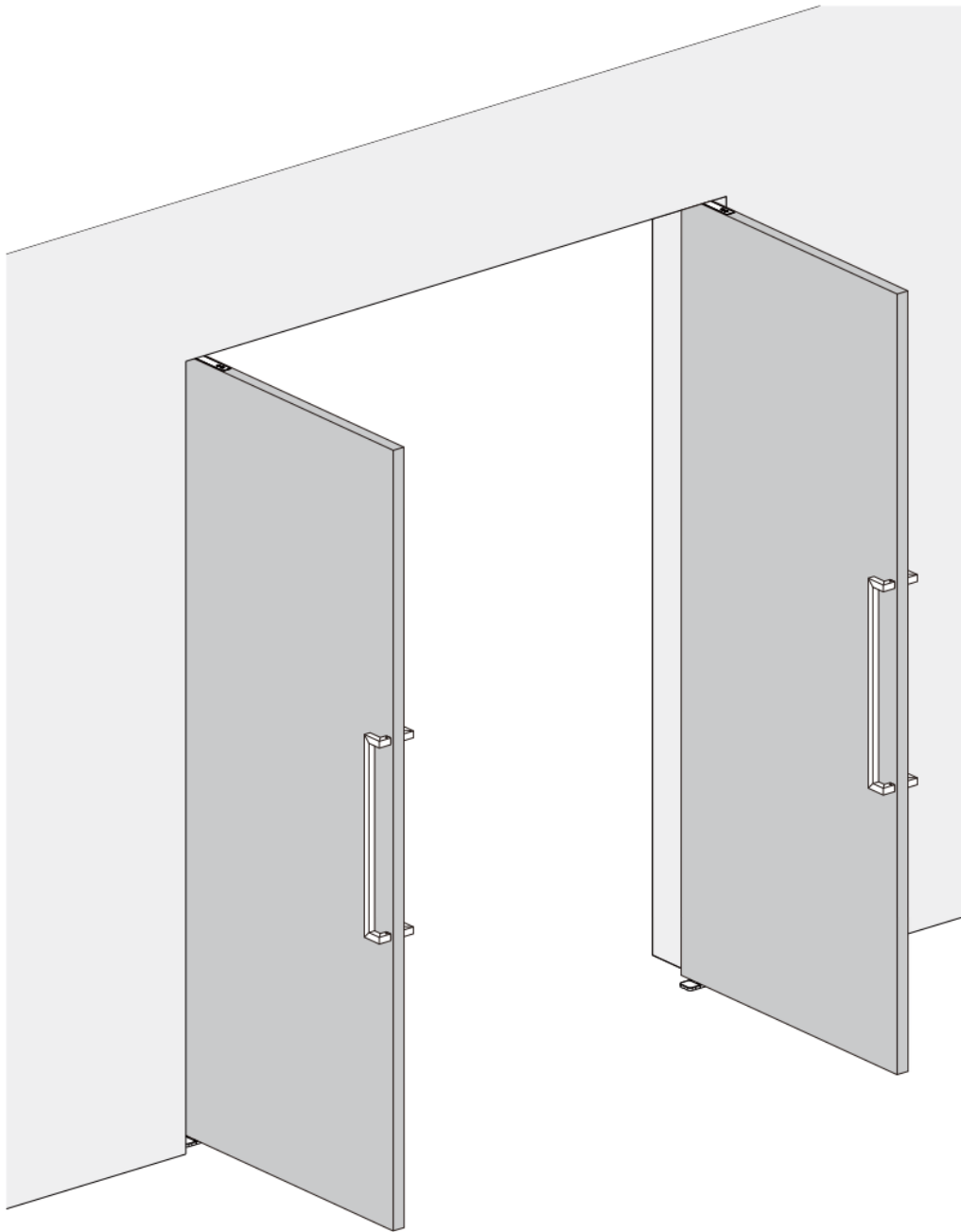

DEGELIJKE
DEUREN

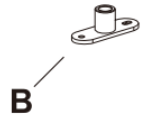



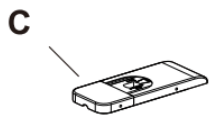
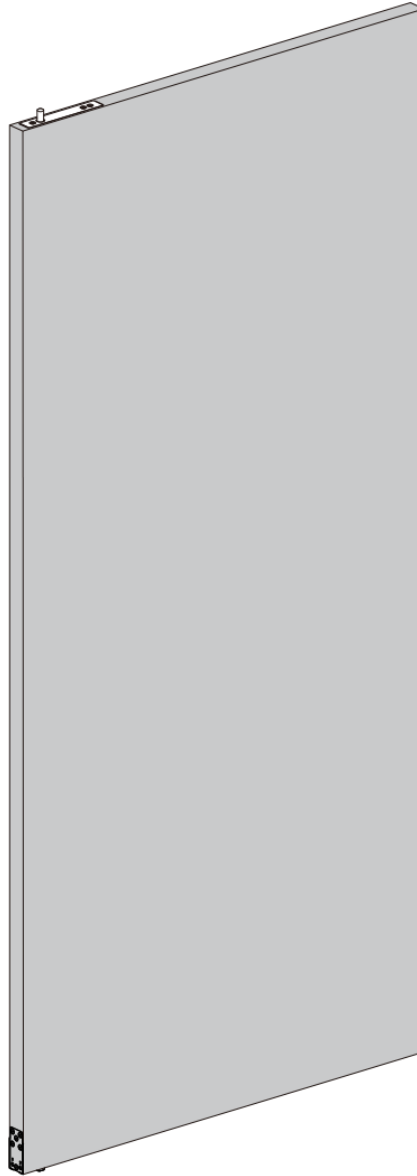



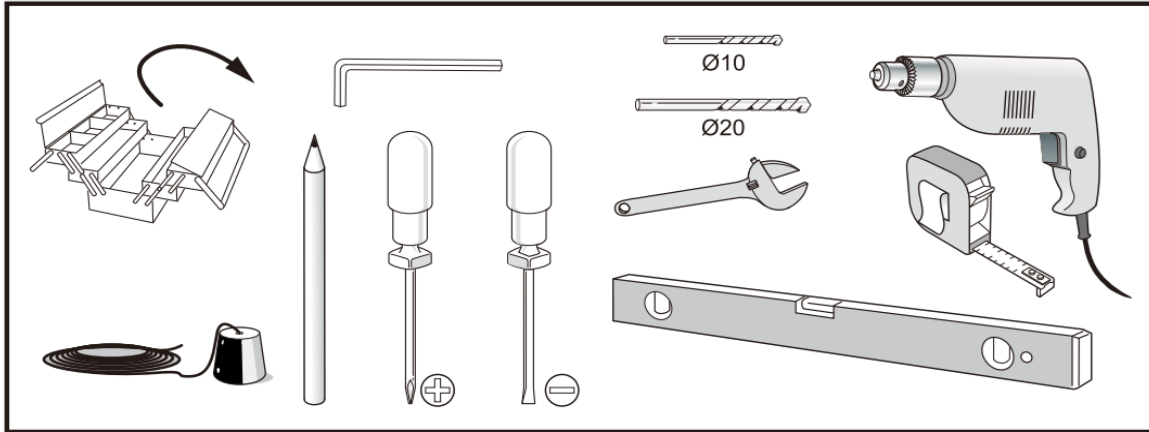

A

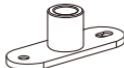

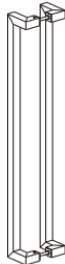
Benodigd gereedschap

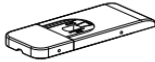

Geleverde onderdelen

A  (x2)	B  (x2)	Bevestiging in hout  ST4.8x25(x4)		D  (x2)
		Bevestiging in steen   ST4.8x38(x4) Ø8 (x4)		
A (x2)	C  (x2)	 M8x25(x8)	 Ø10 (x8)	 (x1)

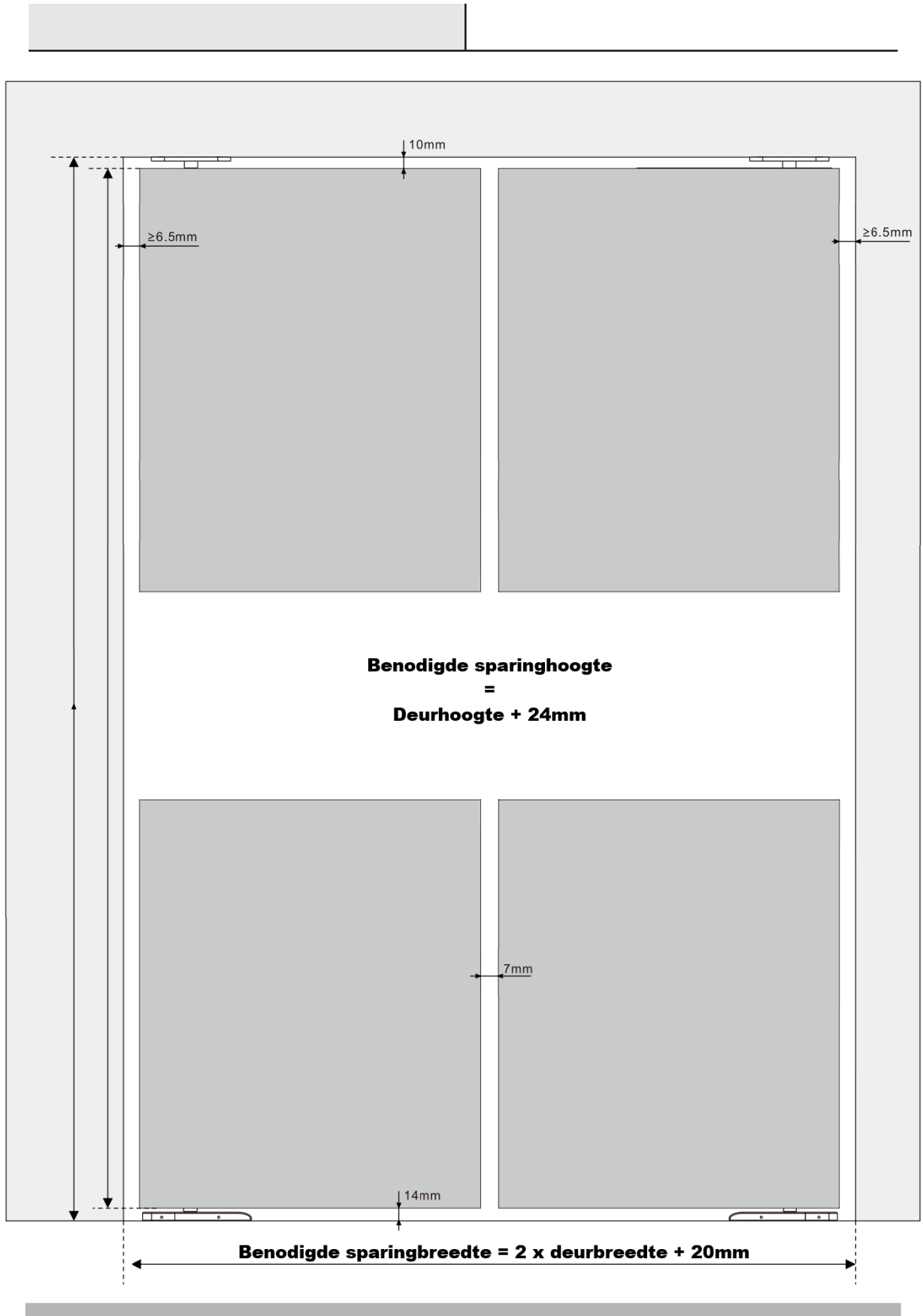

1: Boren van gaten voor de vloerplaat

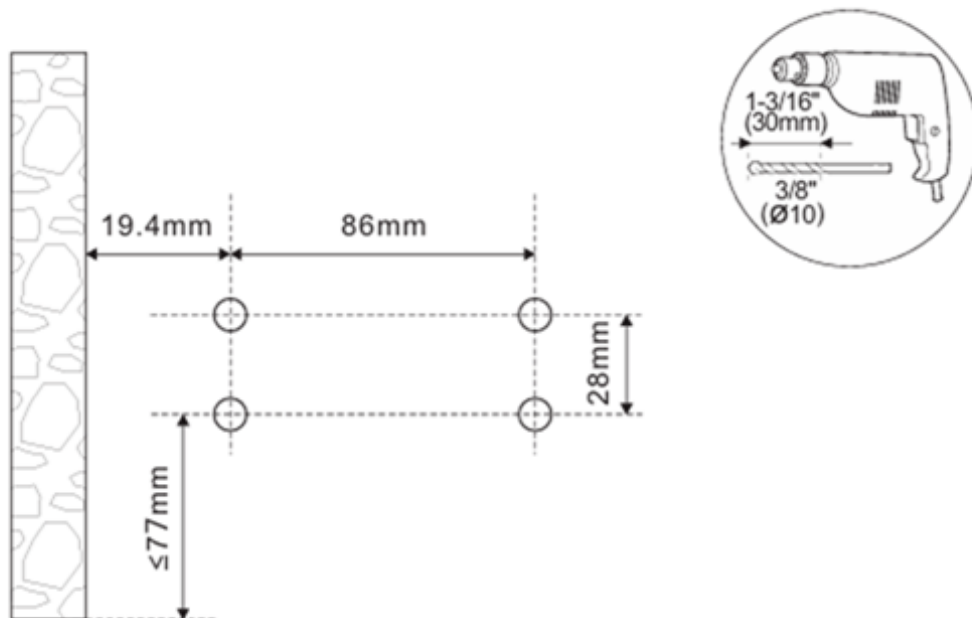

2: Schroef de vloerplaat vast in de grond en stel deze af

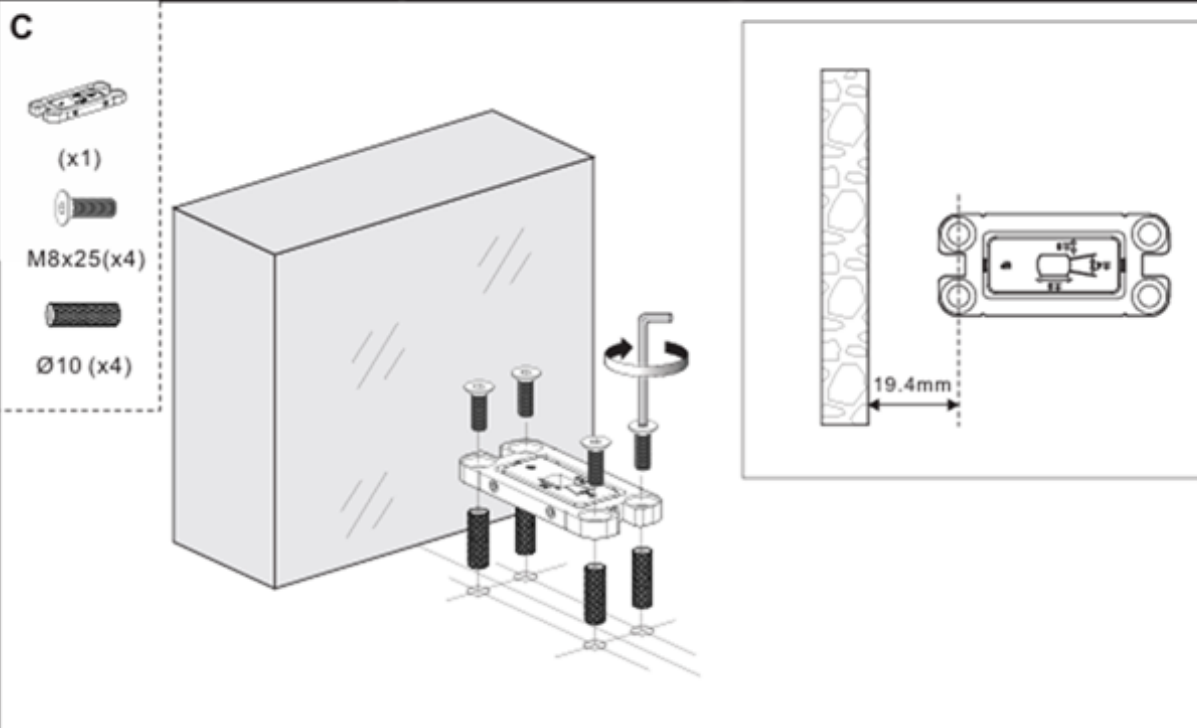

3: Teken het gat voor de bovenspeun af

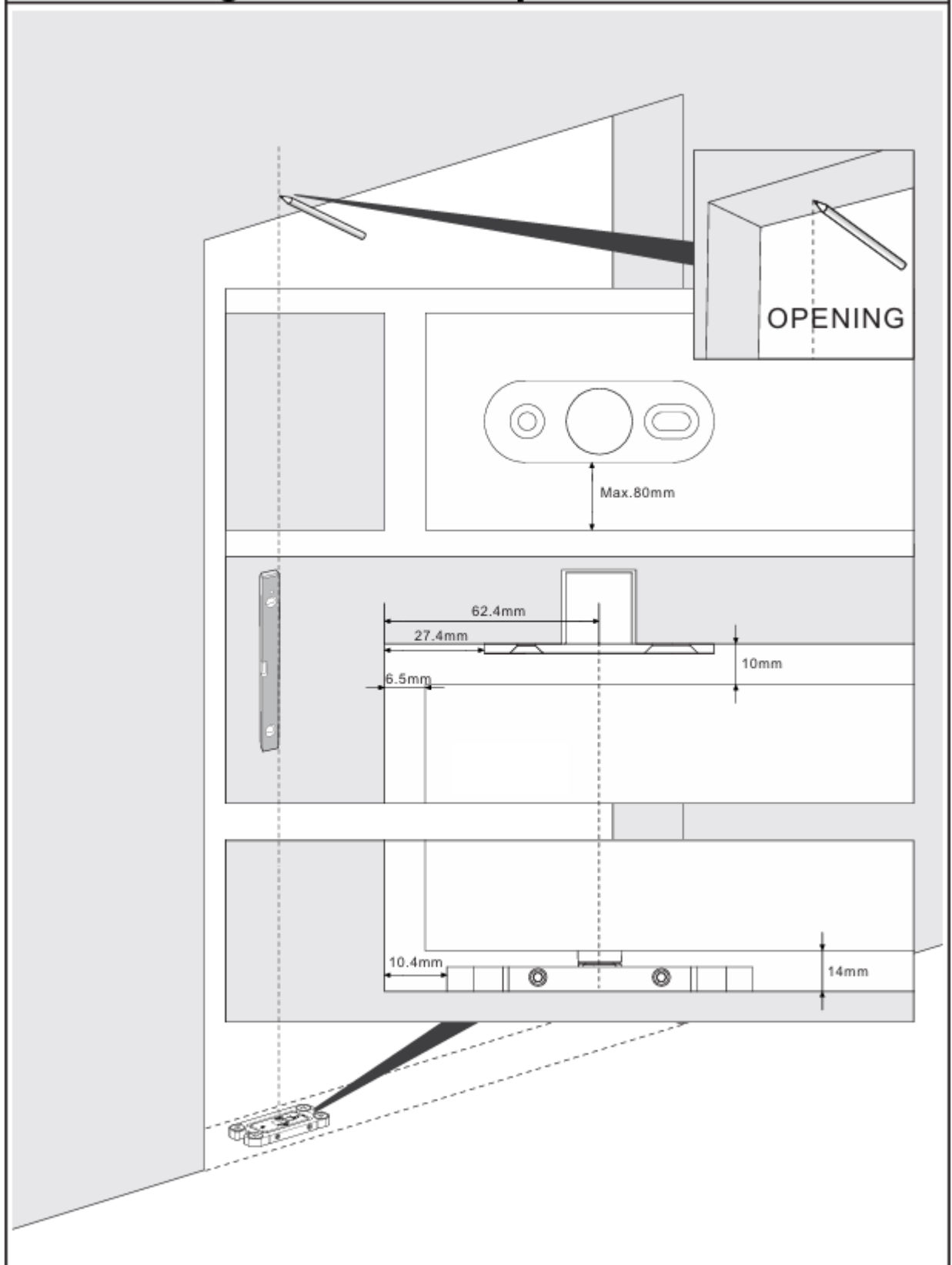

4: Boor het gat

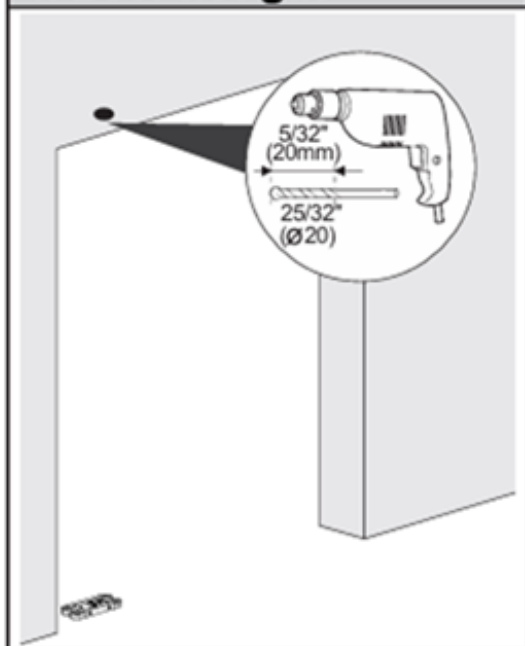

5: Bevestig de bovenspeun

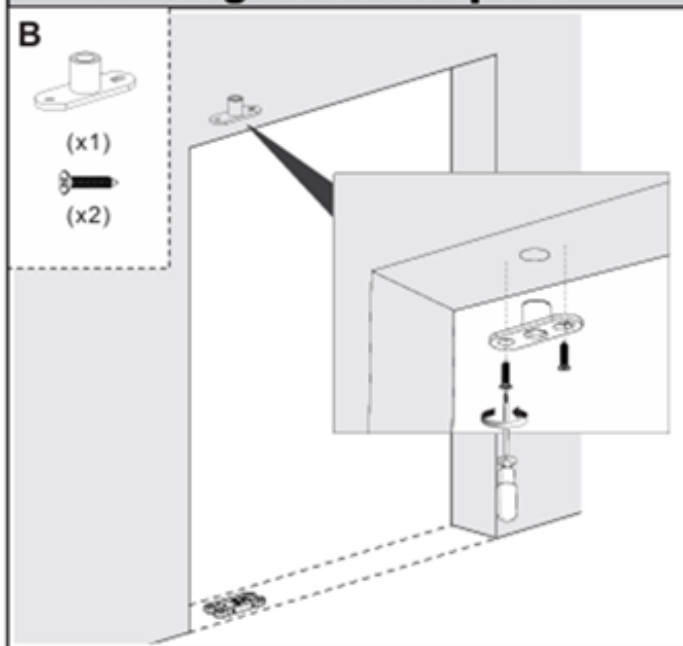

6: Plaats de taatsdeur in positie

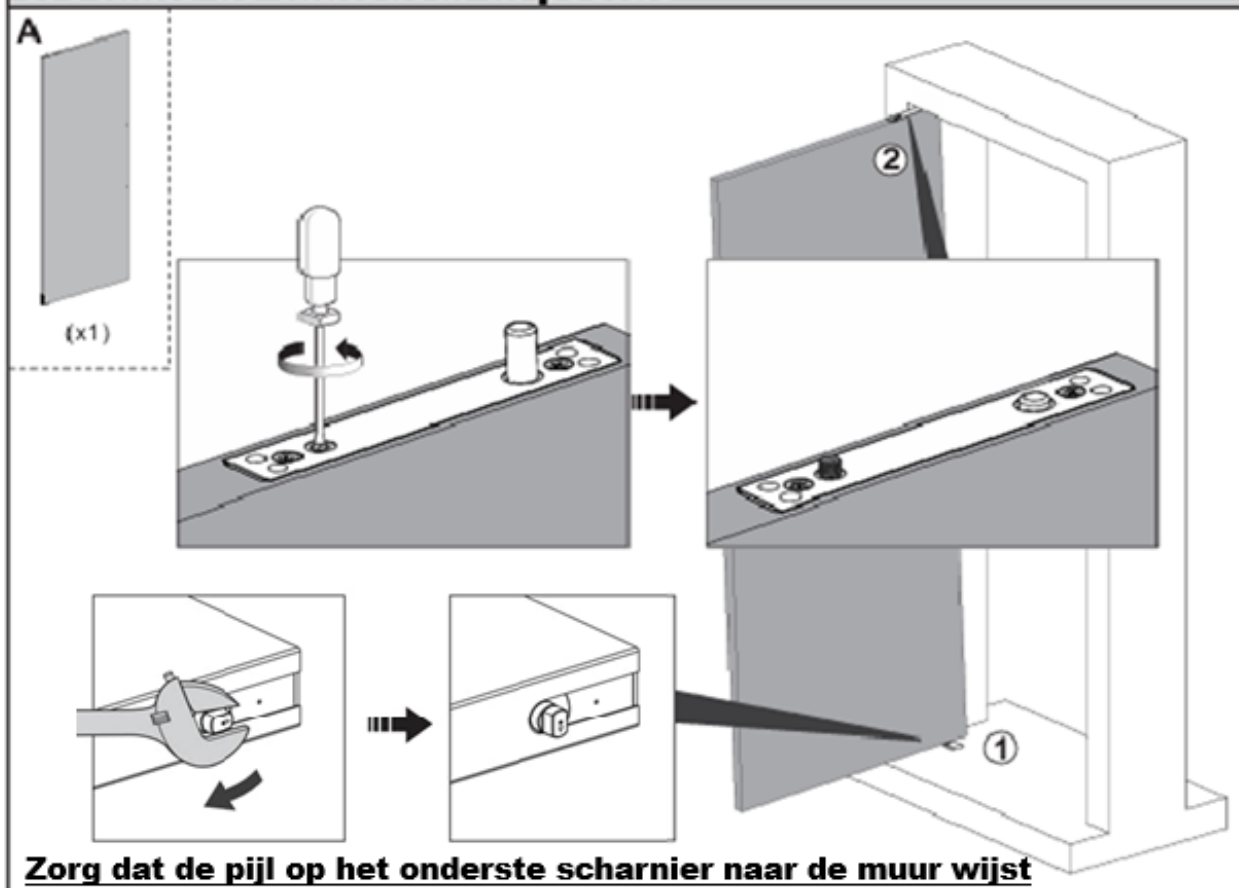

7: Draai het scharnier uit in de bovenspeun

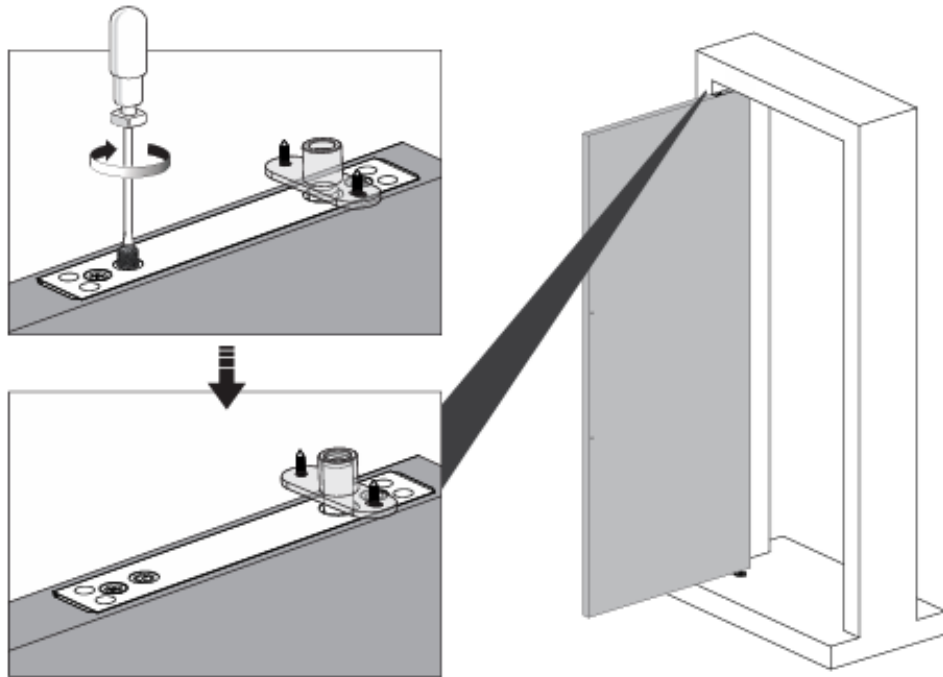

8: Stel de deur af op de vloerplaat

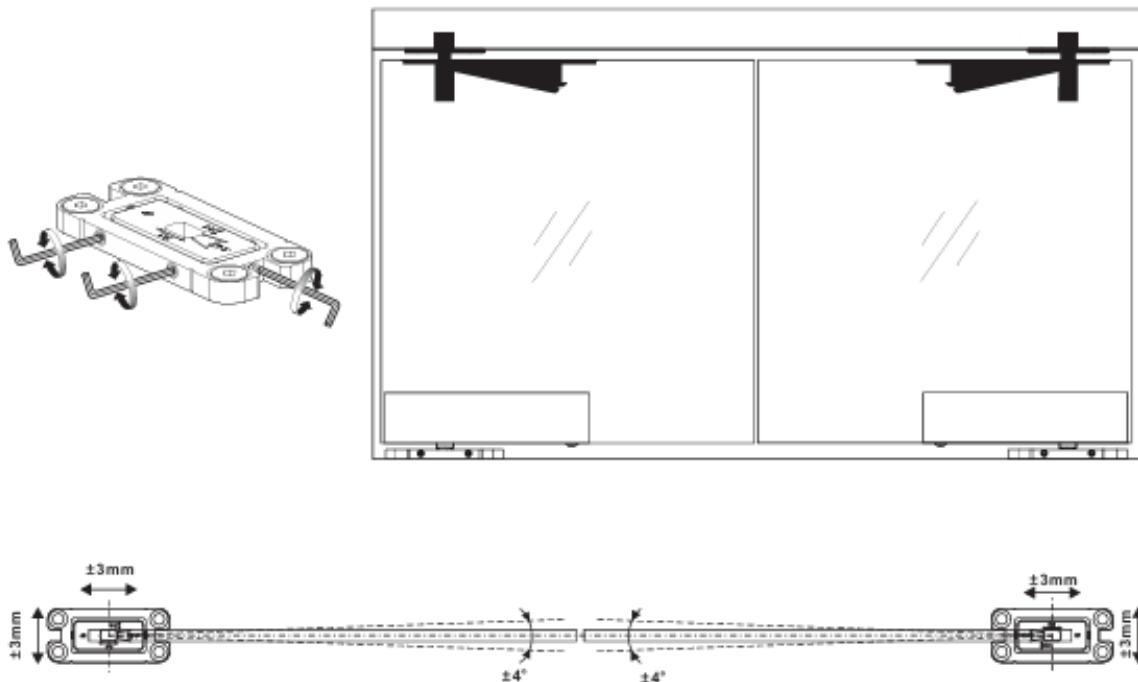

9: Stel de de softclose af het voor gewenste resultaat

Adjust the buffer speed between the first and second speed. Adjust the first speed, then adjust the second speed till door works smoothly. It is a best way to adjust speed to turn speed valves 1/4 circle every time.

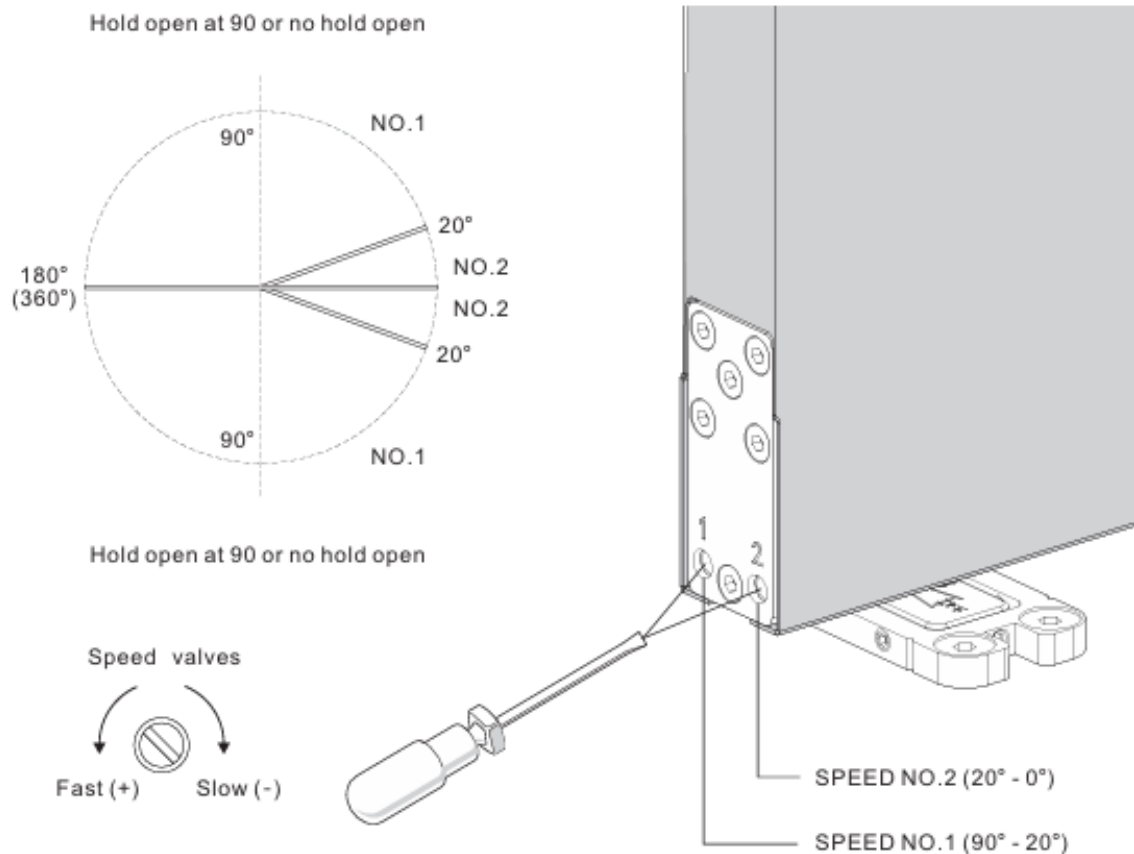

10: Bevestig de kapjes om de vloerplaat af te dekken

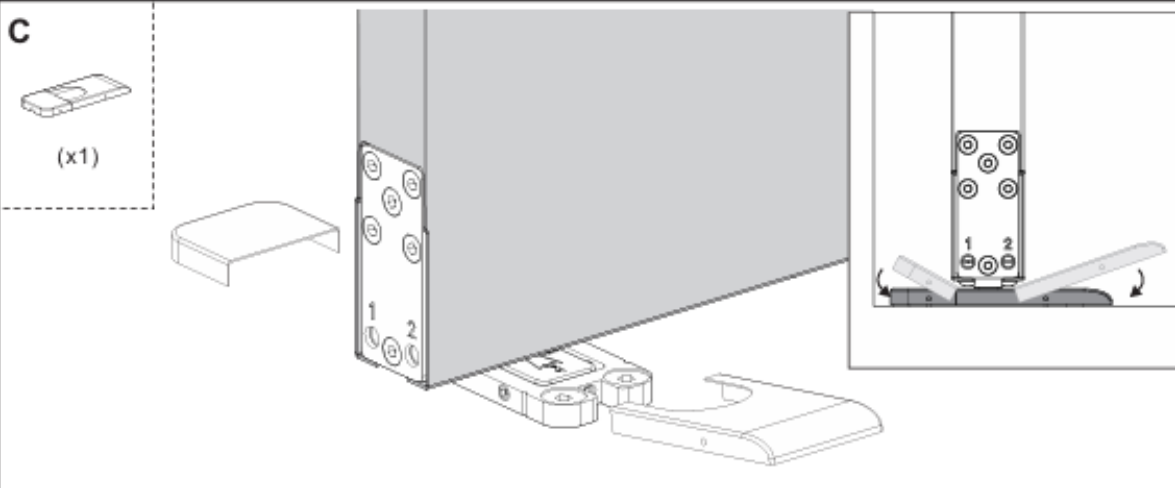

12: Bevestig de standaard mee geleverde deurgreep

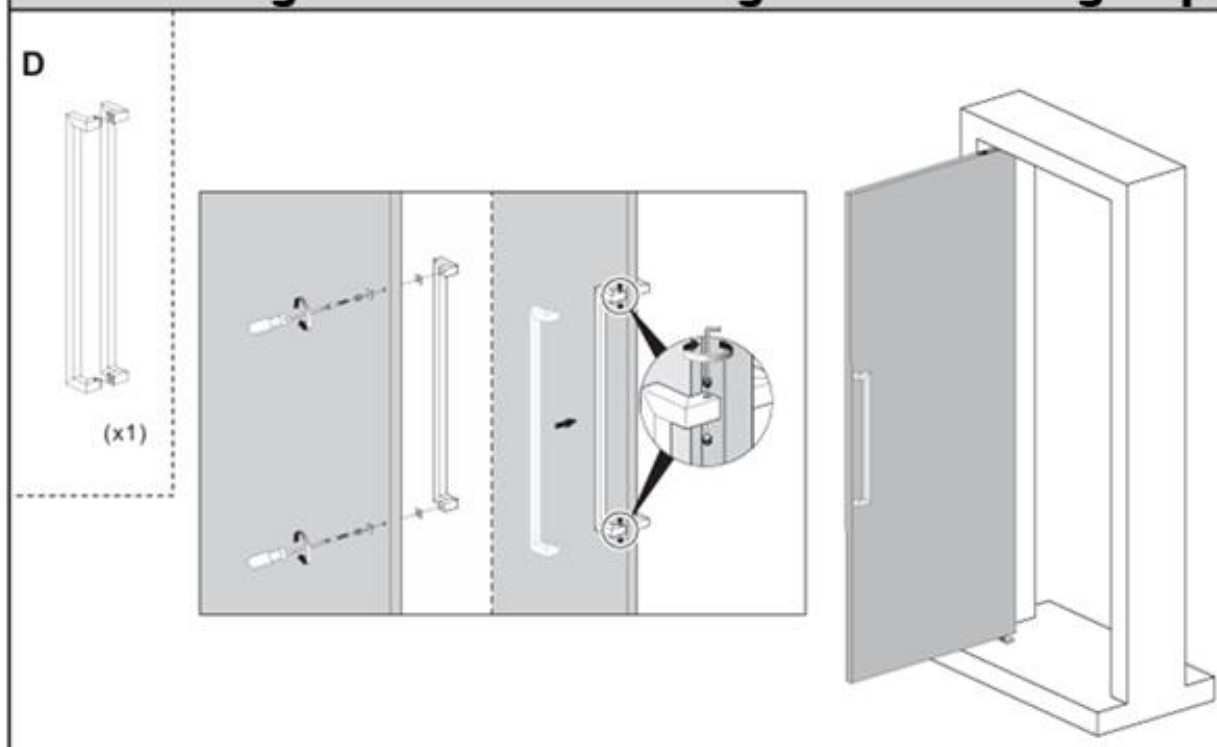

**Hartelijk bedankt
voor uw aankoop!**

**DEGELIJKE
DEUREN**