

X1/X1-Carbon and AMS Quick Start Guide

How to quickly get started with the X1 and X1C

Bambu Lab **X1 & X1-Carbon** 3D Printer Quick Start

Please review the entire guide before operating the printer.

* Safety Notice: Do not connect to power until assembly is complete.

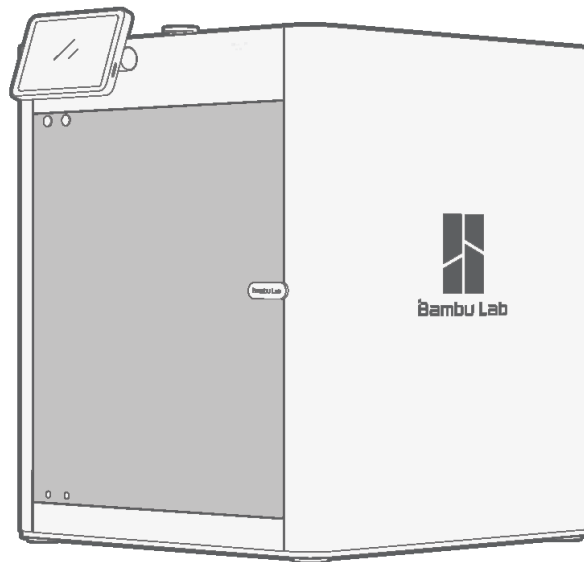



Bambu Studio & Bambu Handy
<https://bambulab.com/download>

Component Introduction

Component Introduction

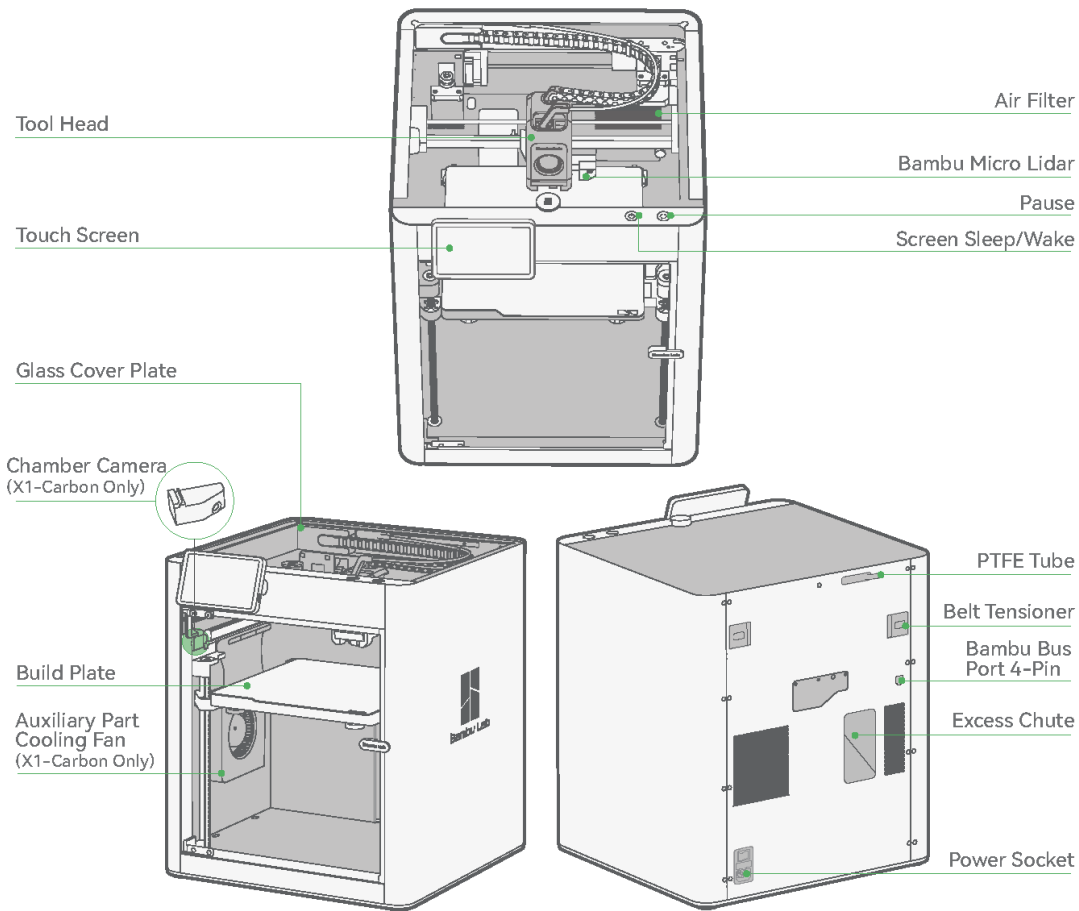

Accessory Specification

Accessory Specification

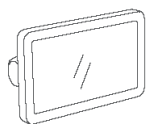

Touch Screen

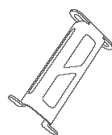

Spool Holder

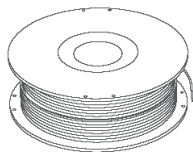

250g Filament

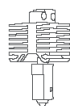

Spare Hot End



Nozzle Wiping Pad (x2)

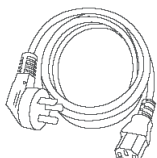

Power Cord



Unclogging Pin Tool

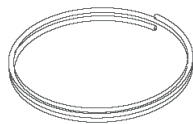

PTFE Tube



Allen Key H1.5
Allen Key H2



Glue Stick for
Build Plate

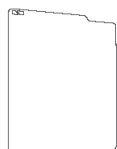

Spare Sheet for
Bambu Cool Plate (x2)

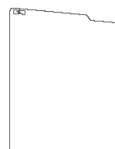

Flexible Build Plate
(Pre-installed on
build plate)

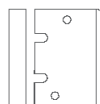

Bambu Scraper

Tool Head Unlock

Tool Head Unlock

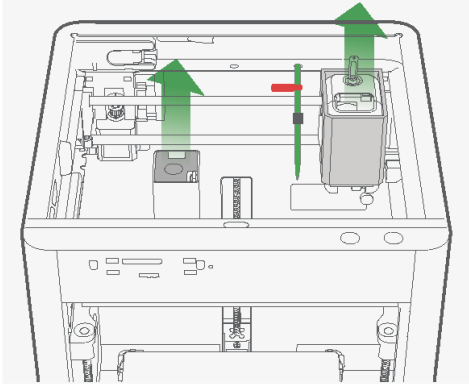

Remove the cardboard from the tool head.
Remove the foam from the excess chute.

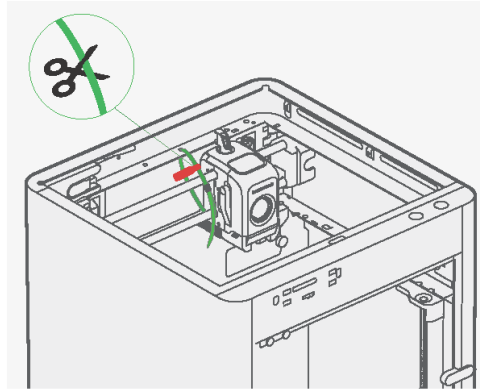

Cut the zip tie securing the toolhead.

Spool Holder Assembly

Spool Holder Assembly

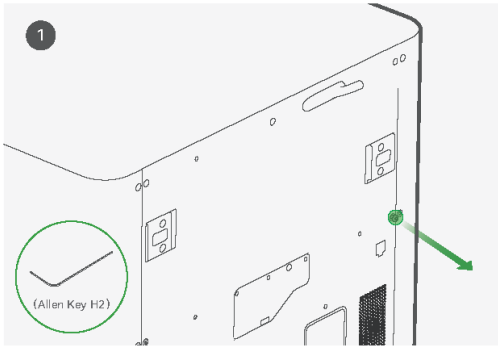

Remove the screw as pictured with an Allen Key H2.

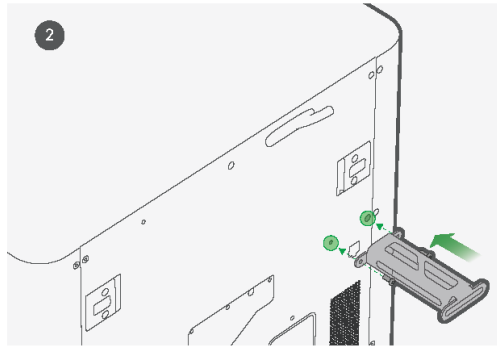

Secure the spool holder with two screws from the accessory box.

*We recommend using the short end of the Allen Key to unlock the screws more easily.

Hot Bed Unlock & Screen Installation

Hot Bed Unlock & Screen Installation

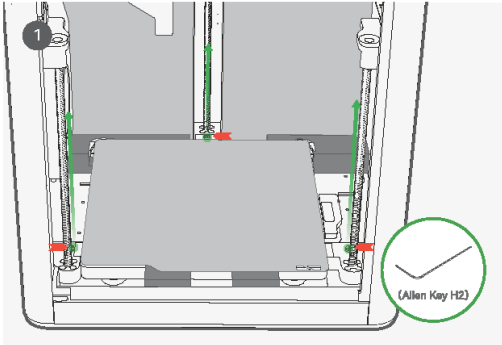

Remove the three screws with an Allen Key H2 to unlock the hot bed.

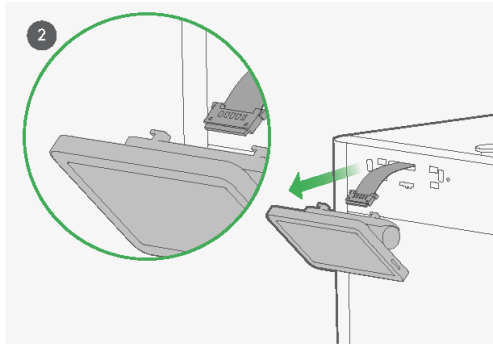

Pull the Flexible Printed Circuit (FPC) out about 50mm.

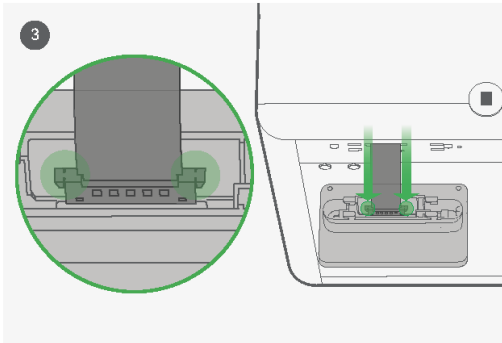

Insert the FPC into the port by pressing the terminal as pictured.

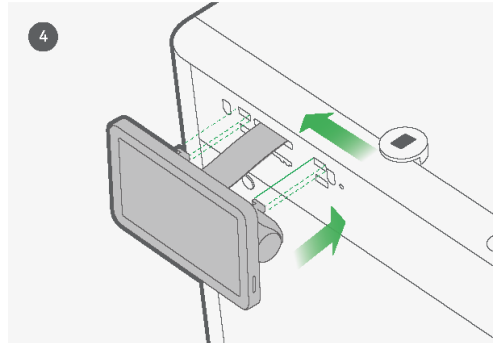

Insert the screen back to the slot on the printer, then lock it by pushing it to the left.

Printer Binding

Printer Binding

1. Download the Bambu Handy App. Register and log in to your Bambu Lab account.



2. Connect the printer to power. Follow the instructions on the screen until getting to the page shown on the right side.

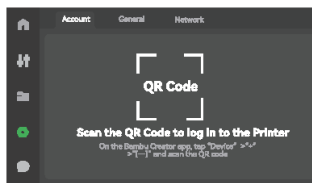

3. Use Bambu Handy to scan the QR code on the screen, and bind your printer with your Bambu Lab account.

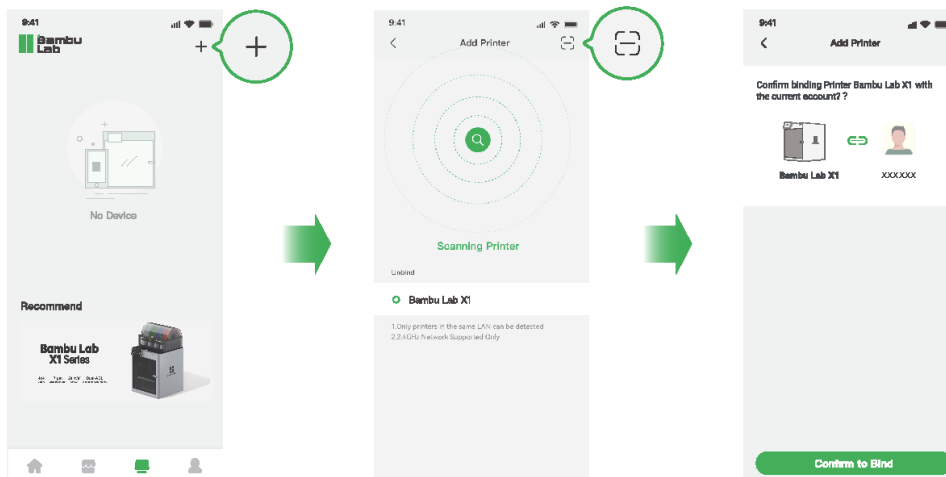

4. Follow the instructions on the screen to complete the initial calibration. It is normal to have vibration and noise during the calibration process.

DO NOT remove the protective foam from beneath the hot bed until after the initial calibration is complete.

First Print

First Print

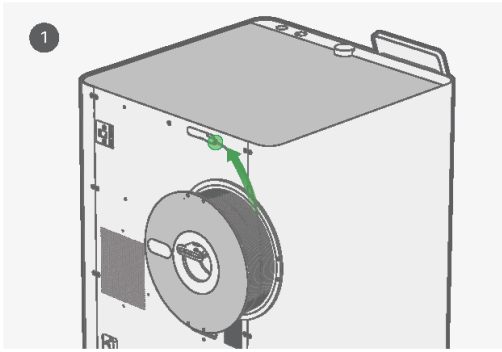

Insert the filament into the PTFE Tube. Keep pushing the filament until it can not move forward.
*We recommend using the supplied Bambu PLA Basic for your first test print.

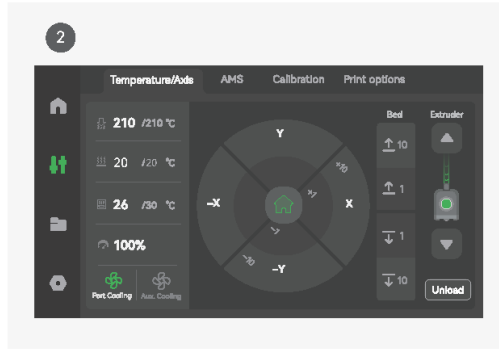

Press "↑" - "↺", and heat the nozzle to the recommended temperature for the filament. Press "Extruder" - "⏻" several times until the filament comes out from the nozzle and cannot be pulled out from the PTFE tube manually.

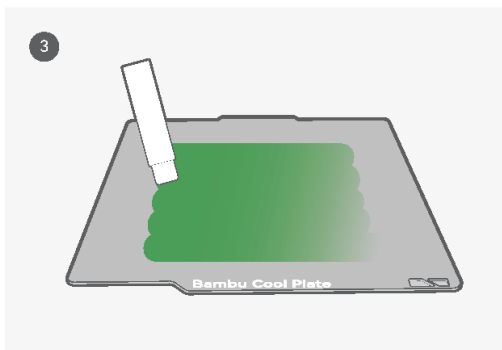

Apply a thin layer of glue on the build plate.

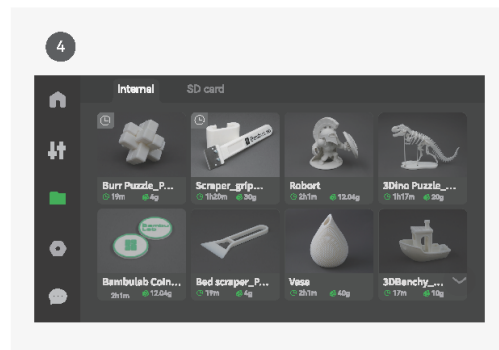

Press "Internal" - "internal". Select a file to start the first print.
*We recommend using one of the pre-loaded files as a first test print.

Bambu Studio

Download Bambu Studio: <http://bambulab.com/download>

Download Bambu Studio: <http://bambulab.com/download>

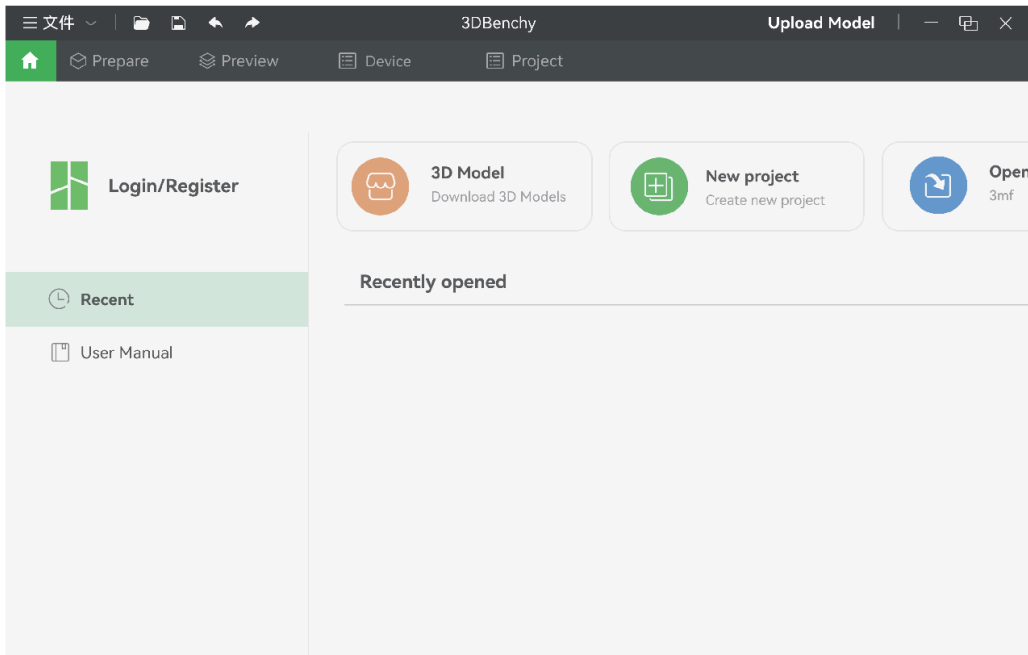

Log in to Bambu Studio with your Bambu Lab account, which is the same for the Bambu Online store. Create or open a project.

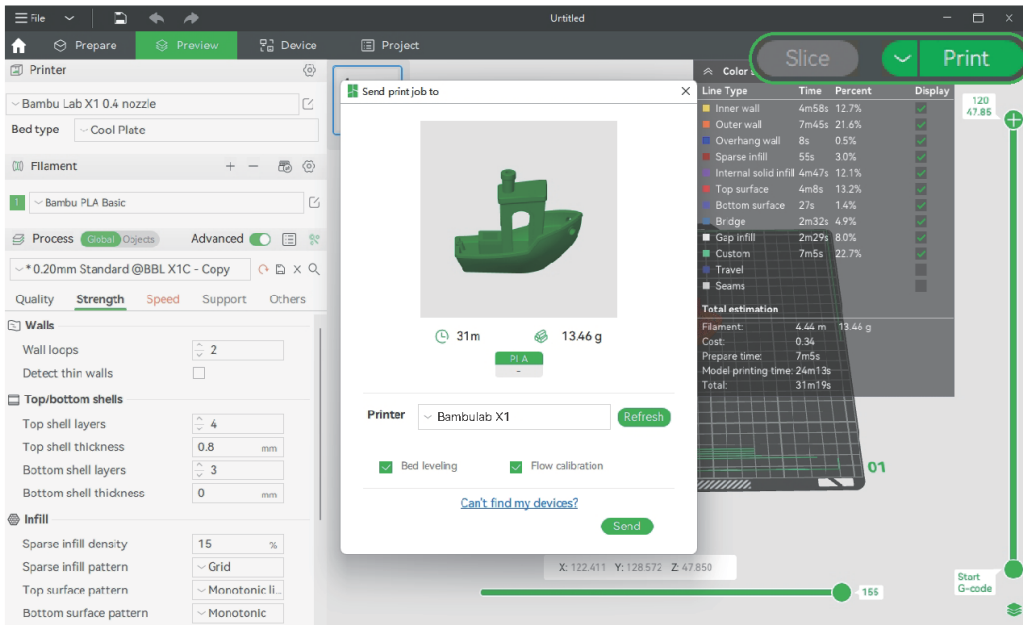

Slice the model, select your printer and send the model to print.

*We recommend performing bed leveling before each print and performing flow calibration after changing filament.

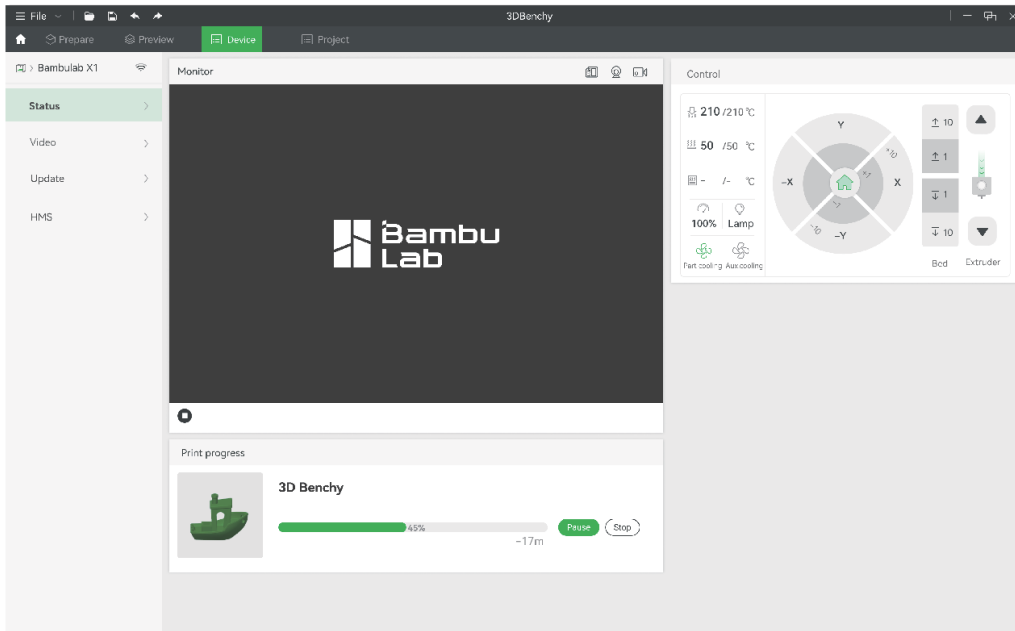

During printing, you can remotely monitor your print, or pause/stop printing on the "Device" interface.

*The live view can be seen only if a camera is mounted.

Specification

Specification

Item		Specification	
		X1-Carbon	X1
Pringing Technology		Fused Deposition Modeling	
Body	Build Volume(W*D*H)	256*256*256 mm	
	Chassis	Steel	
	Shell	Aluminum & Glass	Plastic & Glass
Tool Head	Hot End	All-Metal	
	Extruder Gears	Hardened Steel	Steel
	Nozzle	Hardened Steel	Stainless Steel
	Max Hot End Temperature	300°C	
	Nozzle Diameter (Included)	0.4 mm	
	Nozzle Diameter (Optional)	0.2 mm, 0.6 mm, 0.8 mm	
	Filament Cutter	Yes	
	Filament Diameter	1.75 mm	
Hot bed	Build Plate	Flexible Steel Plate	
	Build Plate Surface(Included)	Bambu Cool Plate, Bambu Engineering Plate	
	Build Plate Surface (Optional)	Bambu High Temperature Plate	
	Max Build Plate Temperature	110°C@220V, 120°C@110V	
Speed	Max Speed of Tool Head	500 mm/s	
	Max Acceleration of Tool Head	20 m/s ²	
	Max Hot End Flow	32 mm ³ /s @ABS	
Cooling	Part Cooling Fan	Closed Loop Control	
	Hot End Fan	Closed Loop Control	
	Control Board Fan	Closed Loop Control	
	Chamber Temperature Regulator Fan	Closed Loop Control	
	Auxiliary Part Cooling Fan	Closed Loop Control	Optional
	Air Filter	Activated Carbon Filter	Optional
Supported Filament	PLA, PETG, TPU,ABS,ASA,PVA,PET	Yes	
	PA, PC	Ideal	Capable
	Carbon/Glass Fiber Reinforced Polymer	Ideal	Not Recommended
Sensors	Bambu Micro Lidar	Yes	
	Chamber Monitoring Camera	1920*1080 Included	Optional
	Door Sensor	Yes	
	Filament Run Out Sensor	Yes	
	Filament Odometry	Optional with AMS	
	Power Loss Recover	Yes	



Physical Dimensions	Dimensions	389*389*457mm	
	Net Weight	14.13kg	13.18kg
Electrical Requirements	Voltage	100-240 VAC, 50/60 Hz	
	Max Power	1000W@220V, 350W@110V	
Electronics	Display	5-inch 1280*720 Touch Screen	
	Connectivity	Wi-Fi, Bambu Bus	
	Storage	4GB EMMC and Micro SD Card Reader	
	Control Interface	Touch Screen, APP, PC Application	
	Motion Controller	Dual-Core Cortex M4	
	Application Processor	Quad ARM A7 1.2 GHz	
Software	Neural-Network Processing Unit	2 Tops	
	Slicer	Bambu Studio Support third party slicers which export standard G-code such as Superslicer, Prusaslicer and Cura, but certain advanced features may not be supported.	
	Slicer Supported OS	MacOS, Windows	
Wifi	Frequency Range	2400MHz-2483.5MHz	
	Transmitter Power (EIRP)	≤ 21.5dBm(FCC) ≤ 20 dBm (CE/SRRC)	
	Protocol	802.11b/g/n	
Laser (Class 2)	Wavelength	405nm, 808nm	
	Maximum Output of Laser Radiation	<1mW	

Support

Please visit the Bambu Lab Wiki for more setup and maintenance tutorials.

<https://wiki.bambulab.com/en/home>



Customer Support

Please visit the Bambu Lab Wiki for more setup and maintenance tutorials.

<https://wiki.bambulab.com/en/home>



If you need support, please try either of the two approaches:

Approach 1: Create a support ticket on the Official Website

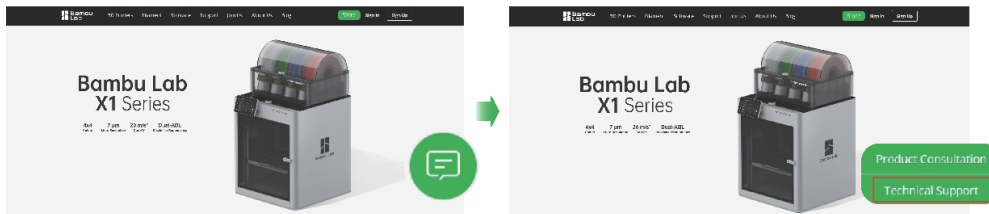

Approach 2: Create a support ticket on the Bambu Handy App

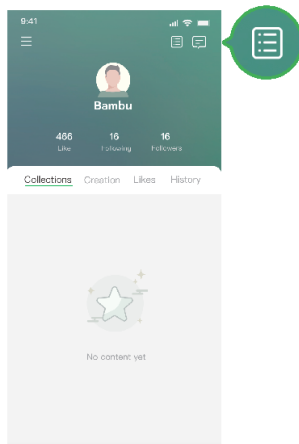



Bambu Lab

Enjoy!

www.bambulab.com