

iQparts
IQ-PARTS-SHOP.COM



**SPECS &
INFORMATION**

Bridge Clamps

These clamps can be manufactured with one or two bridges and for left-hand or right-hand helices. The Double Bridge clamp was developed by the Mikalor R&D Department due to requirements from the ventilation sector and also for applications involving fume, woodchip and dust extraction for a clamp suitable for spiral hose incorporating an outer helix.

Bridge clamps are marked with the application range, material, country of manufacture and the Mikalor logo in compliance with the DIN 3017 norm.

Designed for both manual and automated assembly.

The exclusive design of the housing keeps the screw in firm contact with the band at all times.

Smooth band underside which avoids damage to the hose.

Bevelled band edges to avoid the clip cutting into the hose.





Bridge Clamp ASFA S (12 mm)

ASFA S Bridge Clamps with 12mm bandwidth and manufactured with one or two bridges are an ideal solution for hoses with an outer helix. The geometry and design of the bridges ensure a leaktight fit. These clamps are specially recommended for use on medium-sized and large bore hose mainly used for ventilation or extraction.

** The maximum application pressure can vary depending on the type of hose used and the geometry of the coupling.*

Application Ø mm	Material qualities	Number of bridges	Bridge Position	S +0,10	h max.	a +0,3 a-0,2	b max.	Maximum values		Box Quantity (MOQ)
								Torque (Nm)	Pressure (Bars)	
32-50	W1 W2 W3 W4 W5	1-2	right/left	0,85	11	12	16,7	6,5	32	50
40-60	W1 W2 W3 W4 W5	1-2	right/left	0,85	11	12	16,7	6,5	28	50
50-70	W1 W2 W3 W4 W5	1-2	right/left	0,85	11	12	16,7	7	23	50
60-80	W1 W2 W3 W4 W5	1-2	right/left	0,85	11	12	16,7	7	18	50
70-90	W1 W2 W3 W4 W5	1-2	right/left	0,85	11	12	16,7	7	15	50
80-100	W1 W2 W3 W4 W5	1-2	right/left	0,85	11	12	16,7	7	12	25
90-110	W1 W2 W3 W4 W5	1-2	right/left	0,85	11	12	16,7	7	10	25
100-120	W1 W2 W3 W4 W5	1-2	right/left	0,85	11	12	16,7	7	9	25
110-130	W1 W2 W3 W4 W5	1-2	right/left	0,85	11	12	16,7	7	8	25
120-140	W1 W2 W3 W4 W5	1-2	right/left	0,85	11	12	16,7	7	7	25
130-150	W1 W2 W3 W4 W5	1-2	right/left	0,85	11	12	16,7	7	6	25
140-160	W1 W2 W3 W4 W5	1-2	right/left	0,85	11	12	16,7	7	5	25
150-170	W1 W2 W3 W4 W5	1-2	right/left	0,85	11	12	16,7	7	4	25
160-180	W1 W2 W3 W4 W5	1-2	right/left	0,85	11	12	16,7	7	3	25
170-190	W1 W2 W3 W4 W5	1-2	right/left	0,85	11	12	16,7	7	2	10
180-200	W1 W2 W3 W4 W5	1-2	right/left	0,85	11	12	16,7	7	2	10
190-210	W1 W2 W3 W4 W5	1-2	right/left	0,85	11	12	16,7	7	1,8	10
200-220	W1 W2 W3 W4 W5	1-2	right/left	0,85	11	12	16,7	7	1,8	10
210-230	W1 W2 W3 W4 W5	1-2	right/left	0,85	11	12	16,7	7	1,6	10
220-240	W1 W2 W3 W4 W5	1-2	right/left	0,85	11	12	16,7	7	1,6	10

** It is recommended to apply 75% of the maximum values contained in the table.*

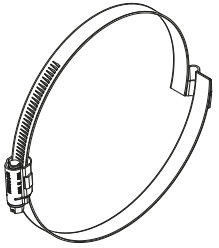
	TECHNICAL INFORMATION	
	MATERIAL	W1: GALVANIZED STEEL W2,W3,W4,W5: STAINLESS STEEL AISI-430, AISI-304, AISI-316
	FINISH	W1: GALVANIZED STEEL W2, W3, W4, W5: STAINLESS STEEL
	CORROSION RESISTANCE	ACCORDING TO MATERIAL USED
	MAXIMUM TIGHTENING SPEED (RPM)	540 ±5

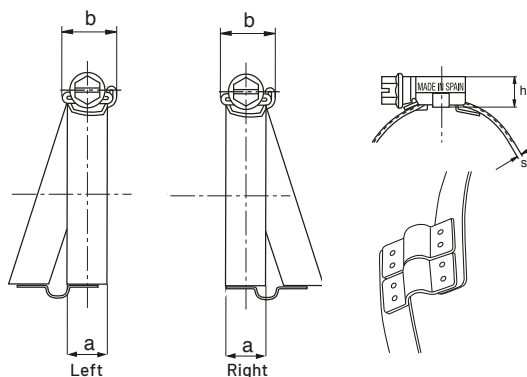



info@iq-parts.nl
Harsweg 34A
2461 EZ Ter Aar
T +31 252 624 126
The Netherlands