

iQ parts
IQ-PARTS-SHOP.COM



**SPECS &
INFORMATION**

**Plastic Worm Drive Hose Clamp,
12.7mm Width, 50mm Diameter, Material PA66
Part No. PWD-13-50-WG-PA66-BK**



Description

Heavy duty polymer worm drive hose clamp with wing spade



Outline Dimensions (General Tolerance \pm 2%)



General Properties PA66 ¹		
Property	Value	Unit
Weight	13.8 (0.49) +/- 2%	g (oz)
Maximum Diameter	54 (2.1)	mm (inch)
Minimum Diameter	25 (0.98)	mm (inch)
Length (A)	198 (7.80)	mm (inch)
Band Width (B)	12.7 (0.5)	mm (inch)
Hex Width (across flats) (C)	8.0 (0.31)	mm (inch)
Band Thickness (D)	3.3 (0.13)	mm (inch)
Head Length inc. Screw (E)	52.8 (2.08)	mm (inch)
Head Width (F)	18.4 (0.72)	mm (inch)

¹PA66 is the material code for Polyamide 6.6. The generic designation is Nylon 6.6.

Main Strap - Material Properties PA66¹

Property	Dry as Moulded	Conditioned 50%RH	Unit	Test Method
Density	1.14		g/cm ³	ISO 1183
Water Absorption Equilibrium (23°C, 50% RH)	2.4		%	
Tensile Modulus (23°C)	3100	1800	MPa	ISO 527-2
Tensile Stress (Yield, +23°C/+73°F)	83 (12.0)	66 (9.6)	MPa (kpsi)	ISO 527-2
Tensile Strain (Yield, +23°C/+73°F)	4.5	25	%	ISO 527-2
Tensile Strain (Break, +23°C/+73°F)	25	105	%	ISO 527-2
Flexural Modulus	2900 (420)	1350 (196)	MPa (kpsi)	ISO 178
Flexural Strength	86 (12.4)	22 (3.2)	MPa (kpsi)	ISO 178
Charpy Unnotched Impact Strength +23°C/+73°F -30°C/-22°F -55°C/-67°F	No break		kJ/m ² (ft-lb/in ²)	ISO 179
			kJ/m ² (ft-lb/in ²)	ISO 179
	No break		kJ/m ² (ft-lb/in ²)	ISO 179
Charpy Notched Impact Strength +23°C/+73°F -30°C/-22°F	5.3 (2.5)		kJ/m ² (ft-lb/in ²)	ISO 179
	6.6 (3.1)		kJ/m ² (ft-lb/in ²)	ISO 179
Notched Izod Impact Strength (23°C)	5.5 (2.6)		kJ/m ² (ft-lb/in ²)	ISO 180
Heat Deflection Temperature 0.45 MPa, Unannealed 1.82 MPa, Unannealed	200 (392)		°C (°F)	ISO 75-2/B
	70.0 (158)		°C (°F)	ISO 75-2/A
Vicat Softening Temperature 50N 10N	236 (457)		°C (°F)	ISO 306/B
	255 (491)		°C (°F)	ISO 306/B
Melting Temperature	260 (500)		°C (°F)	ISO 11357
Flammability	V-2			UL 94
RoHS Compliance	RoHS Compliant			
UL File Number	E70062			

¹PA66 is the material code for Polyamide 6.6. The generic designation is Nylon 6.6.

Mechanical Tests:

Property	Test Diameter mm (inch)	System Yield Strength	Unit	Test Speed mm/s
System Tensile Test ²	100 (4)	1600 (163) [359]	N (kgf) [lbf]	10

²Tests carried out using parts and the HCL laboratory at ~20°C and ~50% RH (relative humidity) on a steel half shell pipe arrangement.

Property/ Tool Type	Max Torque Setting Nm (lb/ft)	Test Diameter mm (Inch)	Maximum Tension after Installation	Unit
System Retention ³ Torque Driver	2.0Nm	100 (4)	1000 (102) [224]	N (kgf) [lbf]

³The system retention is the expected retention or tension after tightening and depends on tool setup and use. Surface friction and the capstan effect may produce different results.

**Plastic Worm Drive Hose Clamp,
12.7mm Width, 75mm Diameter, Material PA66
Part No. PWD-13-75-WG-PA66-BK**

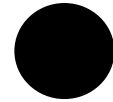

Description

Heavy duty polymer worm drive hose clamp with wing spade



Outline Dimensions (General Tolerance ± 2%)

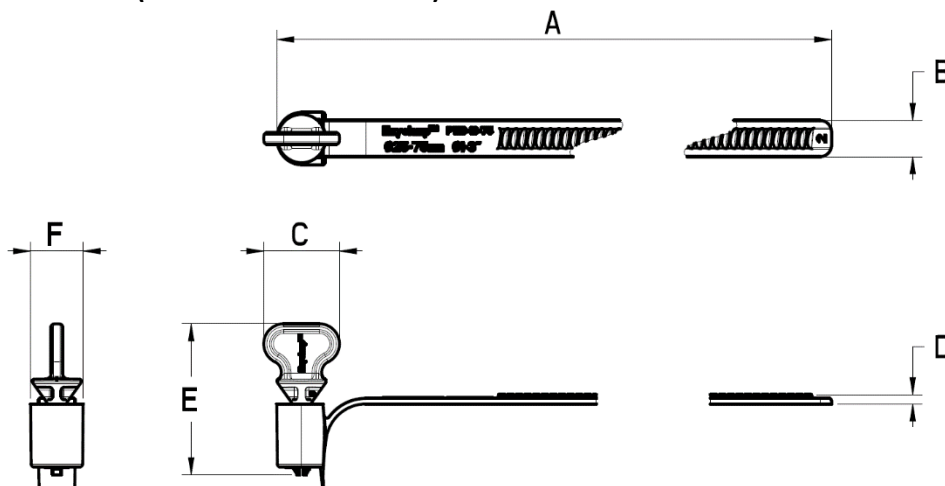

General Properties PA66 ¹		
Property	Value	Unit
Weight	16.3 (0.57) +/- 2%	g (oz)
Maximum Diameter	80 (3.15)	mm (inch)
Minimum Diameter	25 (0.98)	mm (inch)
Length (A)	297 (11.7)	mm (inch)
Band Width (B)	12.7 (0.5)	mm (inch)
Hex Width (across flats) (C)	8.0 (0.31)	mm (inch)
Band Thickness (D)	3.3 (0.13)	mm (inch)
Head Length inc. Screw (E)	52.8 (2.08)	mm (inch)
Head Width (F)	18.4 (0.72)	mm (inch)

¹PA66 is the material code for Polyamide 6.6. The generic designation is Nylon 6.6.

Main Strap - Material Properties PA66¹

Property	Dry as Moulded	Conditioned 50%RH	Unit	Test Method
Density	1.14		g/cm ³	ISO 1183
Water Absorption Equilibrium (23°C, 50% RH)	2.4		%	
Tensile Modulus (23°C)	3100	1800	MPa	ISO 527-2
Tensile Stress (Yield, +23°C/+73°F)	83 (12.0)	66 (9.6)	MPa (kpsi)	ISO 527-2
Tensile Strain (Yield, +23°C/+73°F)	4.5	25	%	ISO 527-2
Tensile Strain (Break, +23°C/+73°F)	25	105	%	ISO 527-2
Flexural Modulus	2900 (420)	1350 (196)	MPa (kpsi)	ISO 178
Flexural Strength	86 (12.4)	22 (3.2)	MPa (kpsi)	ISO 178
Charpy Unnotched Impact Strength +23°C/+73°F -30°C/-22°F -55°C/-67°F	No break		kJ/m ² (ft-lb/in ²)	ISO 179
			kJ/m ² (ft-lb/in ²)	ISO 179
	No break		kJ/m ² (ft-lb/in ²)	ISO 179
Charpy Notched Impact Strength +23°C/+73°F -30°C/-22°F	5.3 (2.5)		kJ/m ² (ft-lb/in ²)	ISO 179
	6.6 (3.1)		kJ/m ² (ft-lb/in ²)	ISO 179
Notched Izod Impact Strength (23°C)	5.5 (2.6)		kJ/m ² (ft-lb/in ²)	ISO 180
Heat Deflection Temperature 0.45 MPa, Unannealed 1.82 MPa, Unannealed	200 (392)		°C (°F)	ISO 75-2/B
	70.0 (158)		°C (°F)	ISO 75-2/A
Vicat Softening Temperature 50N 10N	236 (457)		°C (°F)	ISO 306/B
	255 (491)		°C (°F)	ISO 306/B
Melting Temperature	260 (500)		°C (°F)	ISO 11357
Flammability	V-2			UL 94
RoHS Compliance	RoHS Compliant			
UL File Number	E70062			

¹PA66 is the material code for Polyamide 6.6. The generic designation is Nylon 6.6.

Mechanical Tests:

Property	Test Diameter mm (inch)	System Yield Strength	Unit	Test Speed mm/s
System Tensile Test ²	100 (4)	1600 (163) [359]	N (kgf) [lbf]	10

²Tests carried out using parts and the HCL laboratory at ~20°C and ~50% RH (relative humidity) on a steel half shell pipe arrangement.

Property/ Tool Type	Max Torque Setting Nm (lb/ft)	Test Diameter mm (Inch)	Maximum Tension after Installation	Unit
System Retention ³ Torque Driver	2.0Nm	100 (4)	1000 (102) [224]	N (kgf) [lbf]

³The system retention is the expected retention or tension after tightening and depends on tool setup and use. Surface friction and the capstan effect may produce different results.

**Plastic Worm Drive Hose Clamp,
12.7mm Width, 100mm Diameter, Material PA66
Part No. PWD-13-100-WG-PA66-BK**

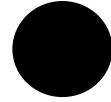

Description

Heavy duty polymer worm drive hose clamp with wing spade



Outline Dimensions (General Tolerance ± 2%)

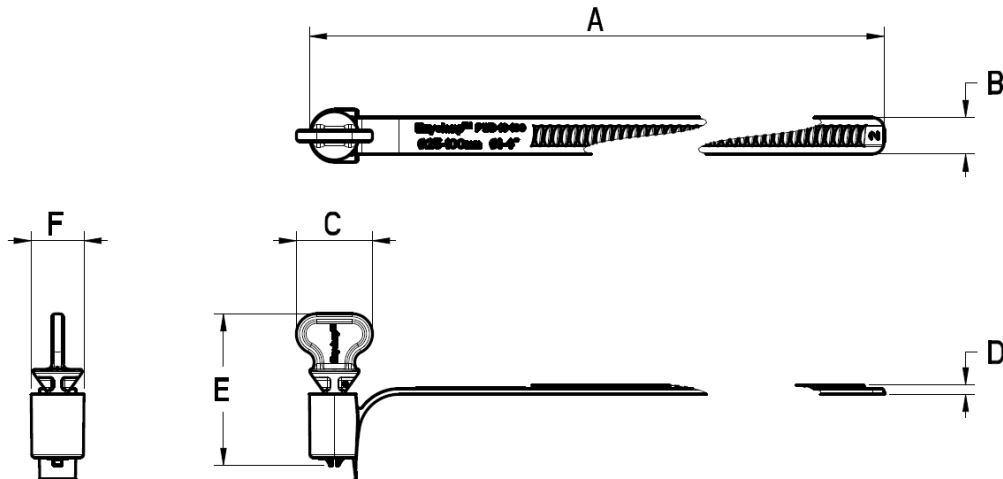

General Properties PA66 ¹		
Property	Value	Unit
Weight	18.7 (0.660) +/- 2%	g (oz)
Maximum Diameter	109 (4.29)	mm (inch)
Minimum Diameter	25 (0.98)	mm (inch)
Length (A)	360 (14.8)	mm (inch)
Band Width (B)	12.7 (0.5)	mm (inch)
Wing Spade Width (C)	26.5 (1.04)	mm (inch)
Band Thickness (D)	3.25 (0.128)	mm (inch)
Head Length inc. Screw (E)	52.8 (2.08)	mm (inch)
Head Width (F)	18.4 (0.72)	mm (inch)

¹PA66 is the material code for Polyamide 6.6. The generic designation is Nylon 6.6.

Main Strap - Material Properties PA66¹

Property	Dry as Moulded	Conditioned 50%RH	Unit	Test Method
Density	1.14		g/cm ³	ISO 1183
Water Absorption Equilibrium (23°C, 50% RH)	2.4		%	
Tensile Modulus (23°C)	3100	1800	MPa	ISO 527-2
Tensile Stress (Yield, +23°C/+73°F)	83 (12.0)	66 (9.6)	MPa (kpsi)	ISO 527-2
Tensile Strain (Yield, +23°C/+73°F)	4.5	25	%	ISO 527-2
Tensile Strain (Break, +23°C/+73°F)	25	105	%	ISO 527-2
Flexural Modulus	2900 (420)	1350 (196)	MPa (kpsi)	ISO 178
Flexural Strength	86 (12.4)	22 (3.2)	MPa (kpsi)	ISO 178
Charpy Unnotched Impact Strength +23°C/+73°F -30°C/-22°F -55°C/-67°F	No break		kJ/m ² (ft-lb/in ²)	ISO 179
			kJ/m ² (ft-lb/in ²)	ISO 179
	No break		kJ/m ² (ft-lb/in ²)	ISO 179
Charpy Notched Impact Strength +23°C/+73°F -30°C/-22°F	5.3 (2.5)		kJ/m ² (ft-lb/in ²)	ISO 179
	6.6 (3.1)		kJ/m ² (ft-lb/in ²)	ISO 179
Notched Izod Impact Strength (23°C)	5.5 (2.6)		kJ/m ² (ft-lb/in ²)	ISO 180
Heat Deflection Temperature 0.45 MPa, Unannealed 1.82 MPa, Unannealed	200 (392)		°C (°F)	ISO 75-2/B
	70.0 (158)		°C (°F)	ISO 75-2/A
Vicat Softening Temperature 50N 10N	236 (457)		°C (°F)	ISO 306/B
	255 (491)		°C (°F)	ISO 306/B
Melting Temperature	260 (500)		°C (°F)	ISO 11357
Flammability	V-2			UL 94
RoHS Compliance	RoHS Compliant			
UL File Number	E70062			

¹PA66 is the material code for Polyamide 6.6. The generic designation is Nylon 6.6.

Mechanical Tests:

Property	Test Diameter mm (inch)	System Yield Strength	Unit	Test Speed mm/s
System Tensile Test ²	100 (4)	1600 (163) [359]	N (kgf) [lbf]	10

²Tests carried out using parts and the HCL laboratory at ~20°C and ~50% RH (relative humidity) on a steel half shell pipe arrangement.

Property/ Tool Type	Max Torque Setting Nm (lb/ft)	Test Diameter mm (Inch)	Maximum Tension after Installation	Unit
System Retention ³ Torque Driver	2.0Nm	100 (4)	1000 (102) [224]	N (kgf) [lbf]

³The system retention is the expected retention or tension after tightening and depends on tool setup and use. Surface friction and the capstan effect may produce different results.

**Plastic Worm Drive Hose Clamp,
12.7mm Width, 125mm Diameter, Material PA66
Part No. PWD-13-125-WG-PA66-BK**

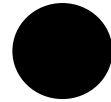

Description

Heavy duty polymer worm drive hose clamp with wing spade



Outline Dimensions (General Tolerance \pm 2%)

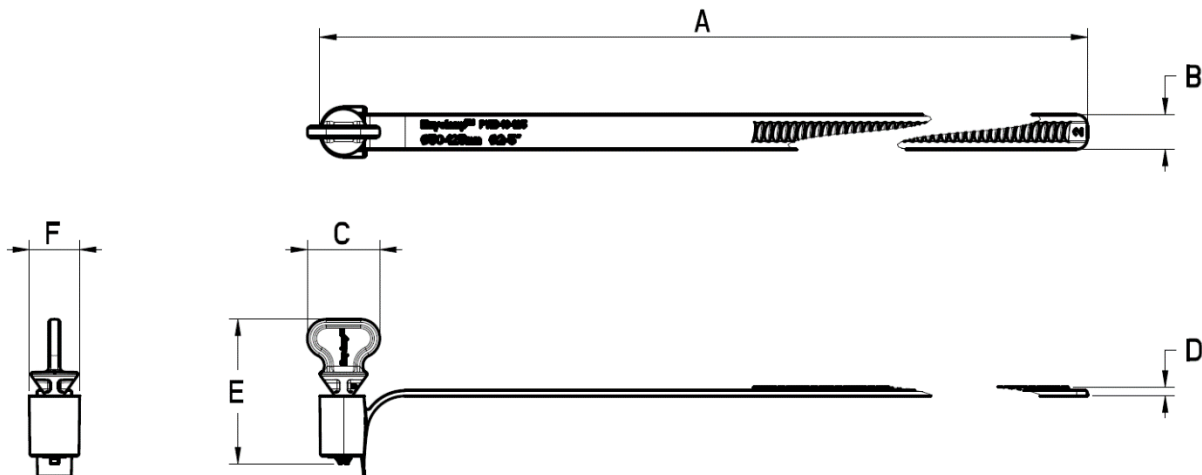

General Properties PA66¹

Property	Value	Unit
Weight	20.8 (0.73) +/- 2%	g (oz)
Maximum Diameter	130 (5.12)	mm (inch)
Minimum Diameter	50 (1.96)	mm (inch)
Length (A)	441 (17.4)	mm (inch)
Band Width (B)	12.7 (0.5)	mm (inch)
Hex Width (across flats) (C)	8.0 (0.31)	mm (inch)
Band Thickness (D)	3.3 (0.13)	mm (inch)
Head Length inc. Screw (E)	52.8 (2.08)	mm (inch)
Head Width (F)	18.4 (0.72)	mm (inch)

¹PA66 is the material code for Polyamide 6.6. The generic designation is Nylon 6.6.

Main Strap - Material Properties PA66¹

Property	Dry as Moulded	Conditioned 50%RH	Unit	Test Method
Density	1.14		g/cm ³	ISO 1183
Water Absorption Equilibrium (23°C, 50% RH)	2.4		%	
Tensile Modulus (23°C)	3100	1800	MPa	ISO 527-2
Tensile Stress (Yield, +23°C/+73°F)	83 (12.0)	66 (9.6)	MPa (kpsi)	ISO 527-2
Tensile Strain (Yield, +23°C/+73°F)	4.5	25	%	ISO 527-2
Tensile Strain (Break, +23°C/+73°F)	25	105	%	ISO 527-2
Flexural Modulus	2900 (420)	1350 (196)	MPa (kpsi)	ISO 178
Flexural Strength	86 (12.4)	22 (3.2)	MPa (kpsi)	ISO 178
Charpy Unnotched Impact Strength +23°C/+73°F -30°C/-22°F -55°C/-67°F	No break		kJ/m ² (ft-lb/in ²)	ISO 179
			kJ/m ² (ft-lb/in ²)	ISO 179
	No break		kJ/m ² (ft-lb/in ²)	ISO 179
Charpy Notched Impact Strength +23°C/+73°F -30°C/-22°F	5.3 (2.5)		kJ/m ² (ft-lb/in ²)	ISO 179
	6.6 (3.1)		kJ/m ² (ft-lb/in ²)	ISO 179
Notched Izod Impact Strength (23°C)	5.5 (2.6)		kJ/m ² (ft-lb/in ²)	ISO 180
Heat Deflection Temperature 0.45 MPa, Unannealed 1.82 MPa, Unannealed	200 (392)		°C (°F)	ISO 75-2/B
	70.0 (158)		°C (°F)	ISO 75-2/A
Vicat Softening Temperature 50N 10N	236 (457)		°C (°F)	ISO 306/B
	255 (491)		°C (°F)	ISO 306/B
Melting Temperature	260 (500)		°C (°F)	ISO 11357
Flammability	V-2			UL 94
RoHS Compliance	RoHS Compliant			
UL File Number	E70062			

¹PA66 is the material code for Polyamide 6.6. The generic designation is Nylon 6.6.

Mechanical Tests:

Property	Test Diameter mm (inch)	System Yield Strength	Unit	Test Speed mm/s
System Tensile Test ²	100 (4)	1600 (163) [359]	N (kgf) [lbf]	10

²Tests carried out using parts and the HCL laboratory at ~20°C and ~50% RH (relative humidity) on a steel half shell pipe arrangement.

Property/ Tool Type	Max Torque Setting Nm (lb/ft)	Test Diameter mm (Inch)	Maximum Tension after Installation	Unit
System Retention ³ Torque Driver	2.0Nm	100 (4)	1000 (102) [224]	N (kgf) [lbf]

³The system retention is the expected retention or tension after tightening and depends on tool setup and use. Surface friction and the capstan effect may produce different results.

**Plastic Worm Drive Hose Clamp,
12.7mm Width, 150mm Diameter, Material PA66
Part No. PWD-13-150-WG-PA66-BK**

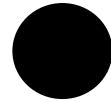

Description

Heavy duty polymer worm drive hose clamp with wing spade



Outline Dimensions (General Tolerance ± 2%)

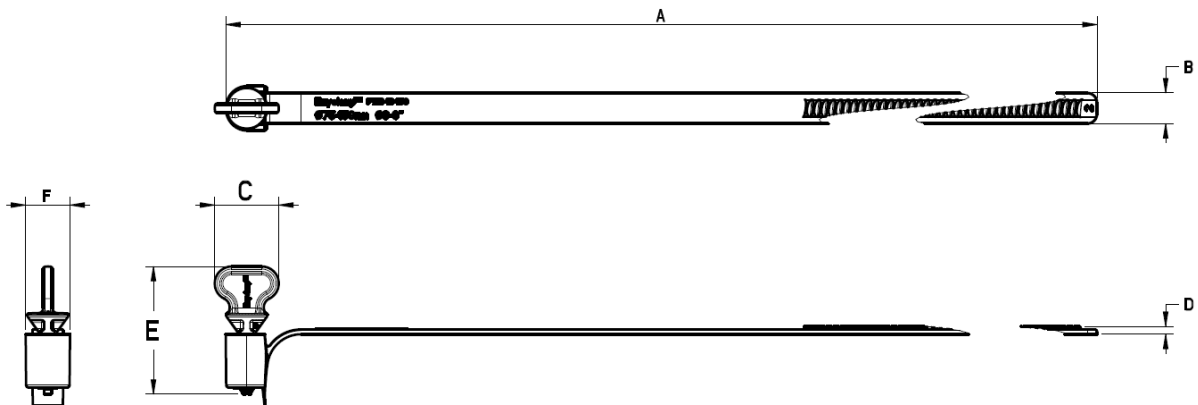

General Properties PA66 ¹		
Property	Value	Unit
Weight	23.2 (0.818) +/- 2%	g (oz)
Maximum Diameter	158 (6.22)	mm (inch)
Minimum Diameter	76 (2.99)	mm (inch)
Length (A)	522 (20.6)	mm (inch)
Band Width (B)	12.7 (0.5)	mm (inch)
Hex Width (across flats) (C)	8.0 (0.31)	mm (inch)
Band Thickness (D)	3.3 (0.13)	mm (inch)
Head Length inc. Screw (E)	52.8 (2.08)	mm (inch)
Head Width (F)	18.4 (0.72)	mm (inch)

¹PA66 is the material code for Polyamide 6.6. The generic designation is Nylon 6.6.

Main Strap - Material Properties PA66¹

Property	Dry as Moulded	Conditioned 50%RH	Unit	Test Method
Density	1.14		g/cm ³	ISO 1183
Water Absorption Equilibrium (23°C, 50% RH)	2.4		%	
Tensile Modulus (23°C)	3100	1800	MPa	ISO 527-2
Tensile Stress (Yield, +23°C/+73°F)	83 (12.0)	66 (9.6)	MPa (kpsi)	ISO 527-2
Tensile Strain (Yield, +23°C/+73°F)	4.5	25	%	ISO 527-2
Tensile Strain (Break, +23°C/+73°F)	25	105	%	ISO 527-2
Flexural Modulus	2900 (420)	1350 (196)	MPa (kpsi)	ISO 178
Flexural Strength	86 (12.4)	22 (3.2)	MPa (kpsi)	ISO 178
Charpy Unnotched Impact Strength +23°C/+73°F -30°C/-22°F -55°C/-67°F	No break		kJ/m ² (ft-lb/in ²)	ISO 179
			kJ/m ² (ft-lb/in ²)	ISO 179
	No break		kJ/m ² (ft-lb/in ²)	ISO 179
Charpy Notched Impact Strength +23°C/+73°F -30°C/-22°F	5.3 (2.5)		kJ/m ² (ft-lb/in ²)	ISO 179
	6.6 (3.1)		kJ/m ² (ft-lb/in ²)	ISO 179
Notched Izod Impact Strength (23°C)	5.5 (2.6)		kJ/m ² (ft-lb/in ²)	ISO 180
Heat Deflection Temperature 0.45 MPa, Unannealed 1.82 MPa, Unannealed	200 (392)		°C (°F)	ISO 75-2/B
	70.0 (158)		°C (°F)	ISO 75-2/A
Vicat Softening Temperature 50N 10N	236 (457)		°C (°F)	ISO 306/B
	255 (491)		°C (°F)	ISO 306/B
Melting Temperature	260 (500)		°C (°F)	ISO 11357
Flammability	V-2			UL 94
RoHS Compliance	RoHS Compliant			
UL File Number	E70062			

¹PA66 is the material code for Polyamide 6.6. The generic designation is Nylon 6.6.

Mechanical Tests:

Property	Test Diameter mm (inch)	System Yield Strength	Unit	Test Speed mm/s
System Tensile Test ²	100 (4)	1600 (163) [359]	N (kgf) [lbf]	10

²Tests carried out using parts and the HCL laboratory at ~20°C and ~50% RH (relative humidity) on a steel half shell pipe arrangement.

Property/ Tool Type	Max Torque Setting Nm (lb/ft)	Test Diameter mm (Inch)	Maximum Tension after Installation	Unit
System Retention ³ Torque Driver	2.0Nm	100 (4)	1000 (102) [224]	N (kgf) [lbf]

³The system retention is the expected retention or tension after tightening and depends on tool setup and use. Surface friction and the capstan effect may produce different results.



info@iq-parts.nl
Harsweg 34A
2461 EZ Ter Aar
T +31 252 624 126
The Netherlands