

iQ parts
IQ-PARTS-SHOP.COM



**SPECS &
INFORMATION**

CN

Antivibrante Conico

Bumper

Cod.	A	B	M	E	Carico max a Compres. Max Compression Load daN
A2CN24	25	22	06MA	20	20
A2CN25	25	22	10MA	20	20
A2CN2525	25	25	06MA	18	18
A2CNT2525 *	25	25	06MA	18	18
A2CN26	25	30	06MA	18	18
A2CN31	30	36	08MA	23	25
A2CN39	40	30	08MA	23	29
A2CN41	40	60	08MA	23	28
A2CN51	50	50	10MA	28	54
A2CN52	50	64	08MA	35	50
A2CN61	60	60	12MA	33	72
A2CN75	75	70	12MA	37	117
A2CN100	100	85	16MA	42	330

Caratteristiche

Materiale corpo: Mescola gomma NR/SBR

Durezza standard: 60 shore A

Tolleranza sulla durezza: +/- 5 SH

A richiesta: Differenti lunghezze della vite

Parte metallica e/o fissaggio:

Vite e rondella zincate

Tipo inserto standard: Vite pressata sulla rondella

Product specification

Main part material:

NR/SBR rubber compound

Standard hardness: 60 shore A

Hardness tolerance: +/- 5 SH

On request: Different screw lengths

Metallic part: Zinc plated screw and washer

Standard thread: Screw pressed on the washer

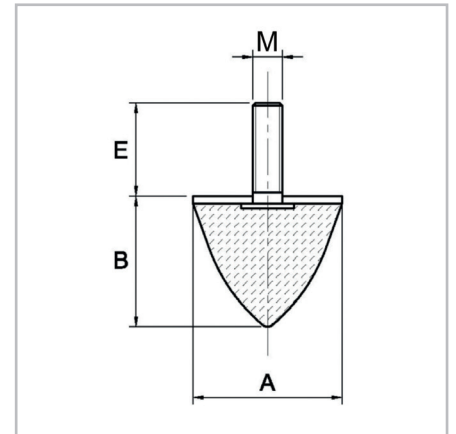

*In NR 45 shore A



info@iq-parts.nl
Harsweg 34A
2461 EZ Ter Aar
T +31 252 624 126
The Netherlands