

iQ parts
IQ-PARTS-SHOP.COM



**SPECS &
INFORMATION**

Breeze Hi-Torque

The Hi-Torque is the world's strongest worm-gear clamp and features all-stainless-steel construction.



5/8" Band Width | Inner Liner Available | SAE Standard J1508 Type HD | Diameter Range 1" – 9 1/8"

HTM / HP HI-TORQUE

5/16" 410 Stainless Steel Hex Screw
5/8" Band in 300-Series SS
Two-Piece Housing in 300-Series SS

HTM L HI-TORQUE W/ LINER

5/16" 410 Stainless Steel Hex Screw
5/8" Band in 300-Series SS with Liner
Two-Piece Housing in 300-Series SS

HP SP HI-TORQUE

5/16" 300-Series SS Hex Screw
5/8" Band in 300-Series SS
Two-Piece Housing in 300-Series SS

HTS / HPS HI-TORQUE

5/16" 316 Stainless Steel Hex Screw
5/8" Band in 316 Stainless Steel
Two-Piece Housing in 316 Stainless Steel

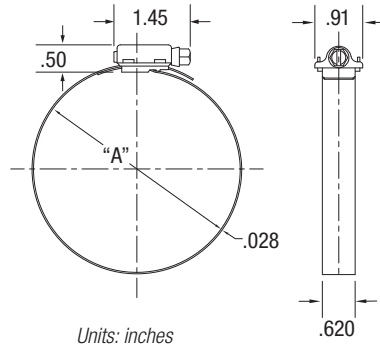

SAE	HTM HI-TORQUE		HTM L HI-TORQUE W/LINER		HTS HI-TORQUE		inches (A)		mm	
	Brand PN	Global PN	Brand PN	Global PN	Brand PN	Global PN	min	max	min	max
-	HTM 175	0156 0015 035	HTM 175 L	0156 0021 035	HTS 175	0156 0019 035	1	1 3/4	25	44
212	HTM 200	0156 0015 043	HTM 200 L	0156 0021 043	HTS 200	0156 0019 043	1 1/4	2 1/8	32	54
262	HTM 250	0156 0015 056	HTM 250 L	0156 0021 056	HTS 250	0156 0019 056	1 3/4	2 5/8	45	67
312	HTM 300	0156 0015 068	HTM 300 L	0156 0021 068	HTS 300	0156 0019 068	2 1/4	3 1/8	57	79
362	HTM 350	0156 0015 081	HTM 350 L	0156 0021 081	HTS 350	0156 0019 081	2 3/4	3 5/8	70	92
412	HTM 400	0156 0015 094	HTM 400 L	0156 0021 094	HTS 400	0156 0019 094	3 1/4	4 1/8	83	105
462	HTM 450	0156 0015 106	HTM 450 L	0156 0021 106	HTS 450	0156 0019 106	3 3/4	4 5/8	95	117
512	HTM 500	0156 0015 119	HTM 500 L	0156 0021 119	HTS 500	0156 0019 119	4 1/4	5 1/8	108	130
562	HTM 550	0156 0015 132	HTM 550 L	0156 0021 132	HTS 550	0156 0019 132	4 3/4	5 5/8	121	143
612	HTM 600	0156 0015 144	HTM 600 L	0156 0021 144	HTS 600	0156 0019 144	5 1/4	6 1/8	133	156
662	HTM 650	0156 0015 157	HTM 650 L	0156 0021 157	HTS 650	0156 0019 157	5 3/4	6 5/8	146	168
712	HTM 700	0156 0015 170	HTM 700 L	0156 0021 170	HTS 700	0156 0019 170	6 1/4	7 1/8	159	181
762	HTM 750	0156 0015 183	HTM 750 L	0156 0021 183	HTS 750	0156 0019 183	6 3/4	7 5/8	172	194
812	HTM 800	0156 0015 195	HTM 800 L	0156 0021 195	HTS 800	0156 0019 195	7 1/4	8 1/8	184	206
862	HTM 850	0156 0015 208	HTM 850 L	0156 0006 197	HTS 850	0156 0019 208	7 3/4	8 5/8	197	219
912	HTM 900	0156 0015 221	HTM 900 L	0156 0021 221	HTS 900	0156 0019 221	8 1/4	9 1/8	210	232

EXTENDED RANGE HI-TORQUE

SAE	HP HI-TORQUE		HP SP HI-TORQUE		HPS HI-TORQUE		inches (A)		mm	
	Brand PN	Global PN	Brand PN	Global PN	Brand PN	Global PN	min	max	min	max
-	HP 2	0156 0015 049	HP 2 SP	0156 0036 050	HPS 2	0156 0019 049	1 1/4	2 5/8	32	67
-	HP 3	0156 0015 079	HP 3 SP	0156 0036 080	HPS 3	0156 0019 079	2 1/8	4 1/8	54	105
-	HP 4	0156 0015 129	HP 4 SP	0156 0036 129	HPS 4	0156 0019 129	4	6 1/8	102	156
-	HP 5	0156 0015 194	HP 5 SP B	0156 0036 194	HPS 5	0156 0019 194	6 1/8	9 1/8	156	232



info@iq-parts.nl
Harsweg 34A
2461 EZ Ter Aar
T +31 252 624 126
The Netherlands