

iQ parts
IQ-PARTS-SHOP.COM



**SPECS &
INFORMATION**

QUICK CONNECTORS

V2

V2 plastic quick connectors are an ideal means to connect media carrying lines as well as ventilation and exhaust lines in automotive industry. The connectors can be used for both line-to-line and line-to-device connections. V2 can be applied on both plastic and metal spigots.



Easily combined with other NORMA Group products such as:

- NORMA Group Fluid Systems (See page 56)

The advantages at a glance

- Quick assembly time equaling cost reduction
- Automated production, no human factor means less margin of error
- No tools needed
- Compact dimensions allowing ease of use in narrow spaces
- An integrated seal provides optimal tightness
- All seals can be visually checked, permitting safe assembly
- Featuring extremely low permeation values

Technical features

- **Medium/Fluid:** Air, oil & fuel vapors
- **Long term operating temperature:** from -40°C to 135°C
- **Short term operating temperature:** up to $+150^{\circ}\text{C}$ (approx. 30 min.)

CONNECTING SPIGOT

NORMA Group standard (Production drawings will be made available on request) V2 quick connectors can be used on both plastic and metal spigots. Please note that all V2 connectors are delivered without spigot. However, we will be pleased to offer suitable spigots on request.

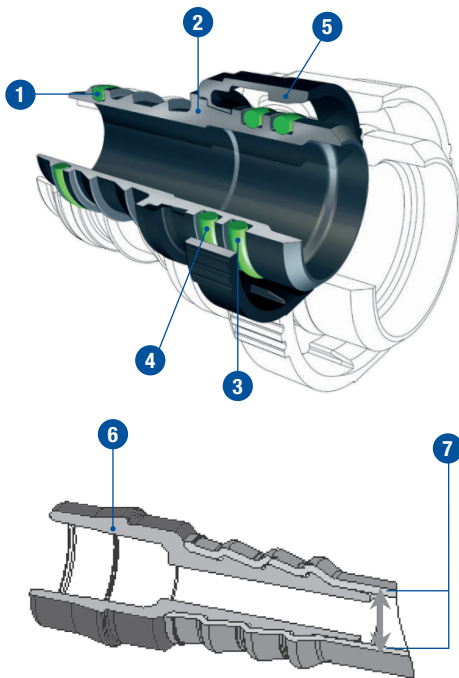

Insider tip

The perfectly matched system is achieved when combining quick connectors and NORMA Group Fluid Systems.



The advantages at a glance

- Fast assembly without tool – reduced time and cost
- Robot assembly possible – automated processes
- Compact dimensions – to be used in narrow spaces
- Integrated seal – optimal tightness
- The seals can be visually checked – safe assembly work

- 1 **Firtree plus O-ring (optional)**
- 2 **Housing**
- 3 **Primary O-ring**
- 4 **Secondary O-ring**
- 5 **Locking device (ring)**
- 6 **Spigot**
- 7 **Pipe inside diameter = Nominal Width (NW)**

Technical features

- **Medium/Fluid:** Air, oil & fuel vapors.
- **Operating pressure:** Approx. 2,5 bar bar excess pressure
- **Operating temperature:** Engine compartment –40°C up to +135°C. Short time up to +150°C (approx. 30 min.)



info@iq-parts.nl
Harsweg 34A
2461 EZ Ter Aar
T +31 252 624 126
The Netherlands