



TWISTER T6 LEAF TRIMMING MACHINE OPERATION MANUAL

Version 1.0

TABLE OF CONTENTS

Important Safety Information	1
Component Overview	2
Initial Assembly	2
T6-Leaf Collector Parts List and Assembly	4
Setup and Operation	5
Leg Leveler	5
Bed Knife Clicker Controls	6
Bed Knife Adjustment	6
Tandem Setup	7
Tandem Leg Leveler	9
Tandem Disassembly	9
Maintenance	9
Inspection	10
Cleaning	10
Disassembly Instructions	11
Reassembly Instructions	13
Troubleshooting	16
Warranty	17
Electrical Specifications	18
Replacement Parts	19

IMPORTANT SAFETY INFORMATION

This document refers to the Twister T6 leaf trimming machine as the T6.

The T6 is a high-speed cutting unit that requires special safety precautions to be practiced while in operation to reduce the risk of personal injury.

Improper use of the T6 may cause serious or fatal injury. Please read the precautions and warning labels before using the T6.

Do not lend out or rent your T6 without this operating manual. A first time operator should obtain proper instruction before using this machine.



SAFETY PRECAUTION

Operating the T6 without reading the instructions that accompany a cautionary label i.e.: a “Danger”, “Caution”, “Warning” or “Notice” symbol, may result in serious or fatal injury.

General

- **Do not expose the T6 control box to water.** Always remove before cleaning.
- Do not move, disassemble, clean or inspect the T6 while the power is connected to the machine.
- Replacement parts are specific to the T6 and must be purchased from an authorized dealer only. Substituting factory parts with third-party parts may result in bodily harm or damage to the T6.
- If used, do not allow lubricants or mineral oils to collect on the ground. This could cause a slipping hazard for the operator and others working in the area.
- Keep everyone a safe distance from your work area. Never operate the T6 around children.
- Do not remove safety labels. **Replace any and all safety labels if they become damaged or obscured.**

Connection

- Like any home appliance, the T6 must be used in connection with a properly grounded receptacle.
- Never plug in or power up the T6 with protective shrouds removed.
- Do not use extension cords over 15m (50ft) in length to power up your T6.

Operation

- The T6 comes from the manufacturer set with the optimal blade contact. The initial set up will show assembly instructions to put the chute and hopper on.
- Safety glasses must be worn at all times when operating the T6.
- Do not operate the T6 while tired or under the influence of drugs, alcohol or medication.
- Do not put objects in the tumbler that cannot be properly processed by the T6. Doing so may cause bodily harm or damage to property. **Plant matter only.**
- Operate the T6 in a well ventilated area to prevent overheating.

Maintenance

- Never let the T6 run unattended.
- Never conduct maintenance while the T6 is plugged in.
- Ensure the T6 is powered off and the machine is unplugged before cleaning.
- Do not change or modify any part of the T6 or its accessories. Doing so may cause bodily harm or damage to property.

COMPONENT OVERVIEW

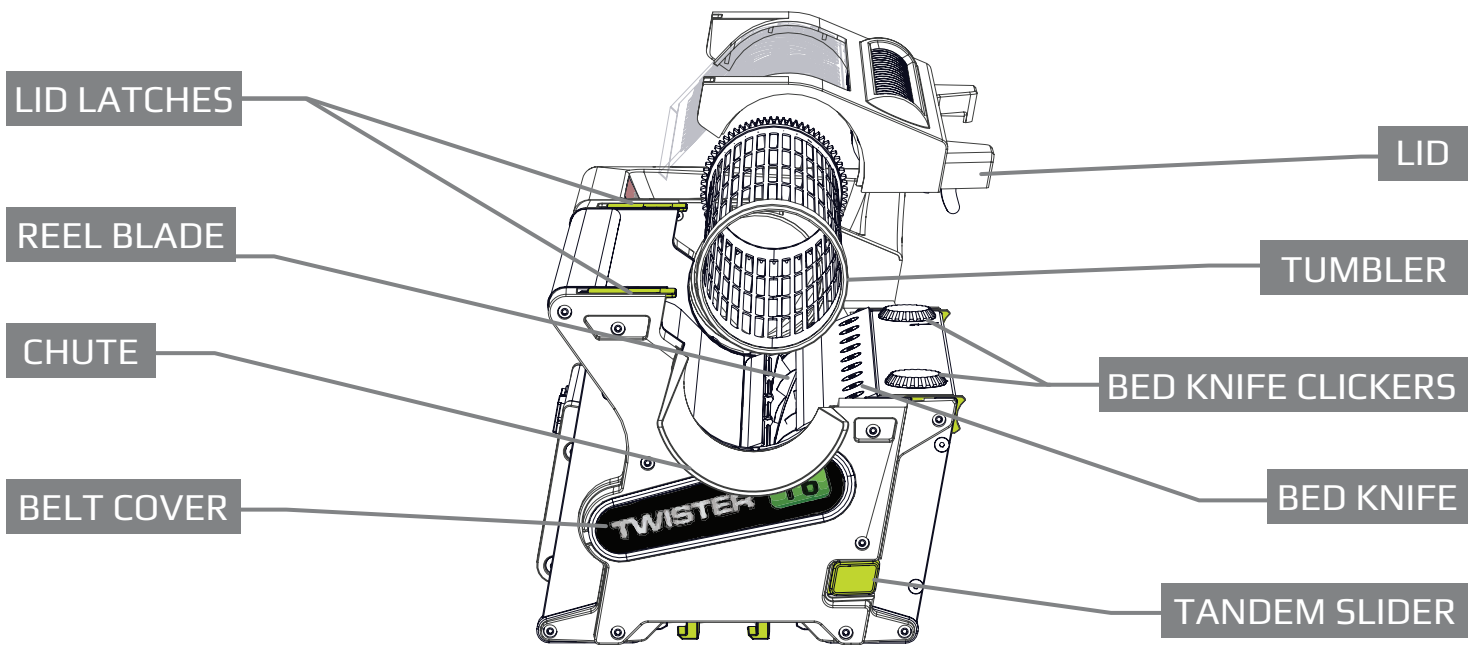
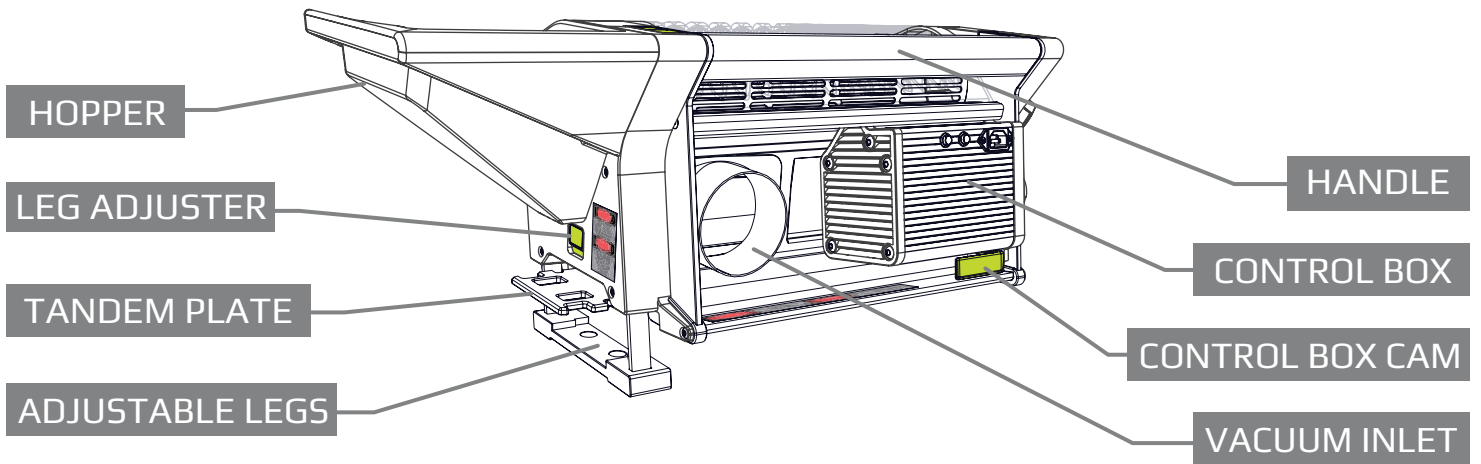

INITIAL ASSEMBLY

1 REMOVE LID AND TUMBLER



1 NEVER PLUG IN MACHINE WITH LID REMOVED

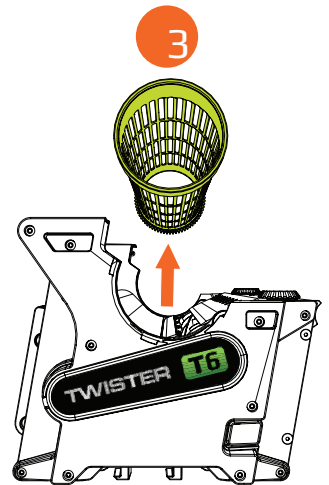
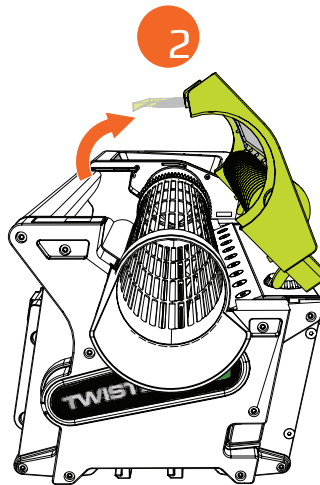
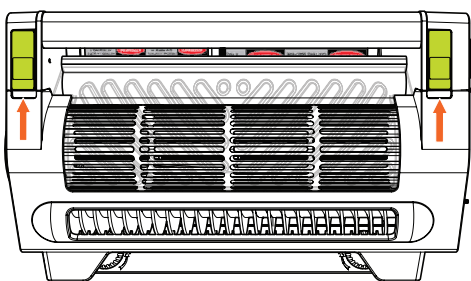

2 INSTALL CHUTE THEN REINSTALL TUMBLER

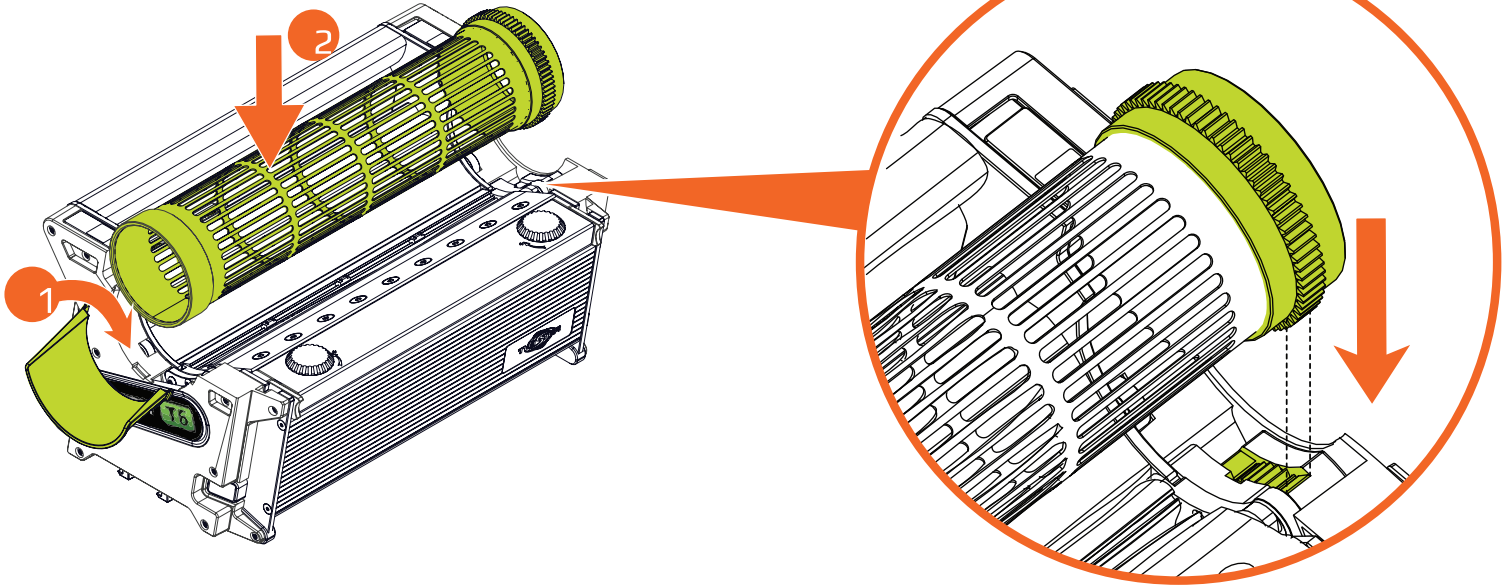

3 INSTALL HOPPER

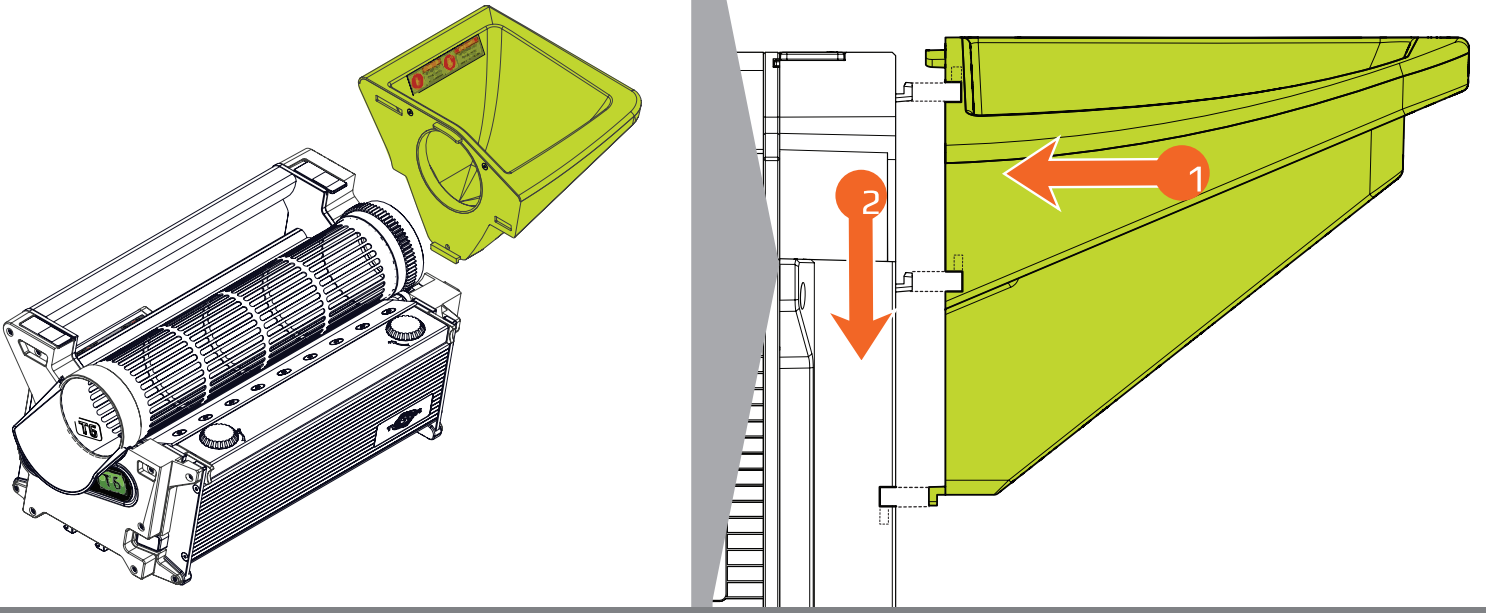

4 REINSTALL LID

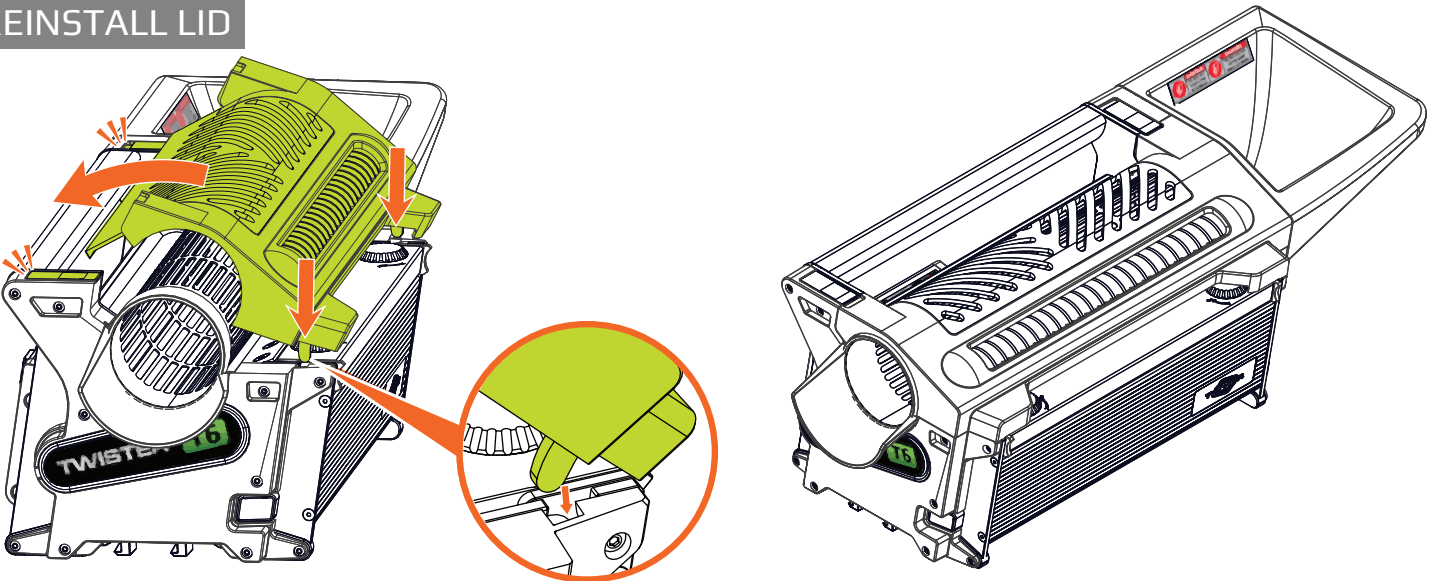

T6-LEAF COLLECTOR (T6-LC) PARTS LIST

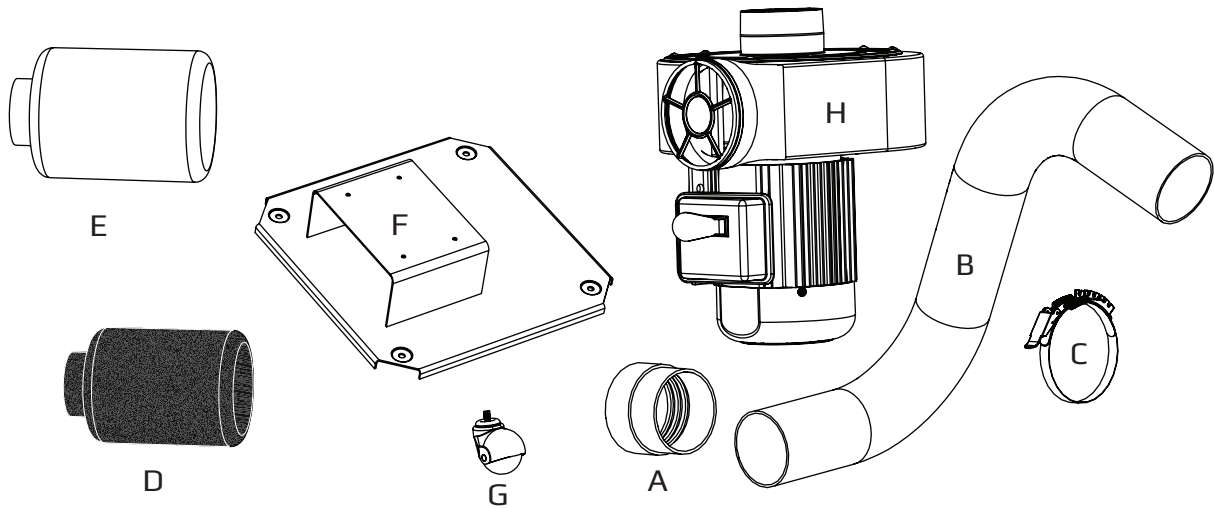

REF	PART NO	DESCRIPTION	QTY
A	23-02-002101	4" HOSE CUFF	2
B	23-02-002102	4" HOSE X 8.25', PVC	1
C	23-02-002103	5" BAG CLAMP, QUICK CONNECT	1
D	23-02-002104	BLACK FILTER BAG, 5" MOUNT, 200-400 MICRON	1
E	23-02-002105	WHITE FILTER BAG, 5" MOUNT, 70 MICRON	1
F	23-02-002106	VACUUM BASEPLATE	1
G	23-02-002107	CASTER	4
H	23-02-002108	1 HP VACUUM MOTOR	1

TOOLS NEEDED

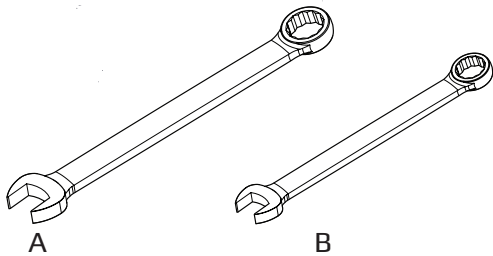

REF	DESCRIPTION
A	7/16" OR 10 MM WRENCH
B	1/2" OR 12 MM WRENCH

FASTENERS

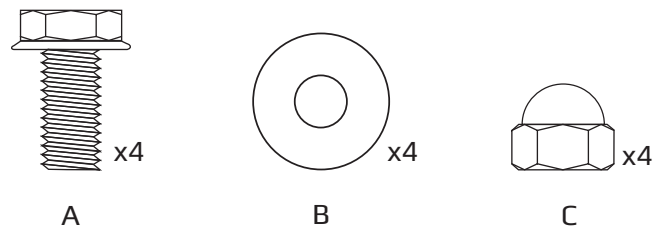

REF	DESCRIPTION
A	1/4-20 X 3/4" HEX HEAD SCREW
B	5/16" FLAT WASHER
C	5/16" ACORN NUT

T6-LC ASSEMBLY

1

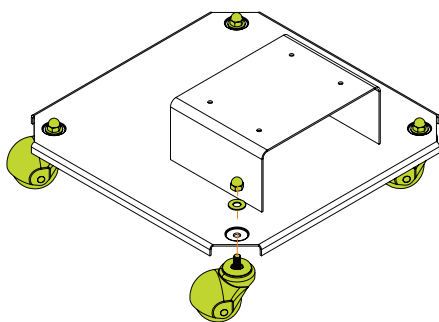

2

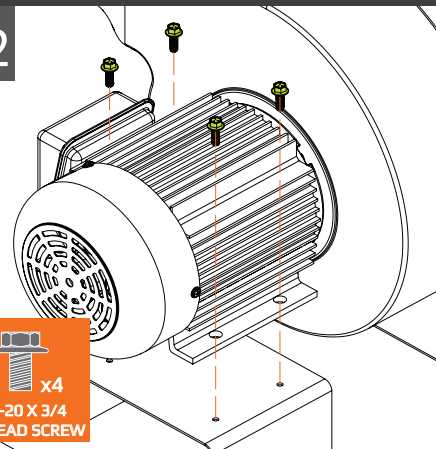

3

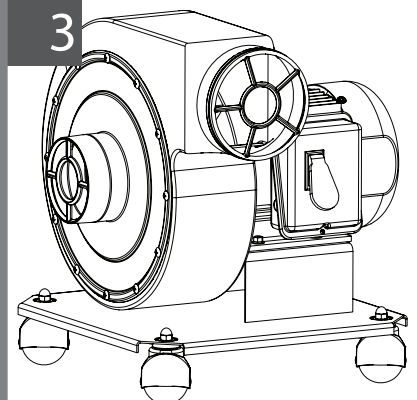

4

SETUP AND OPERATION

1

APPLY DISH SOAP OR ISOPROPYL ALCOHOL TO THE INSIDE OF THE HOSE CUFF TO HELP TWIST IT ON.

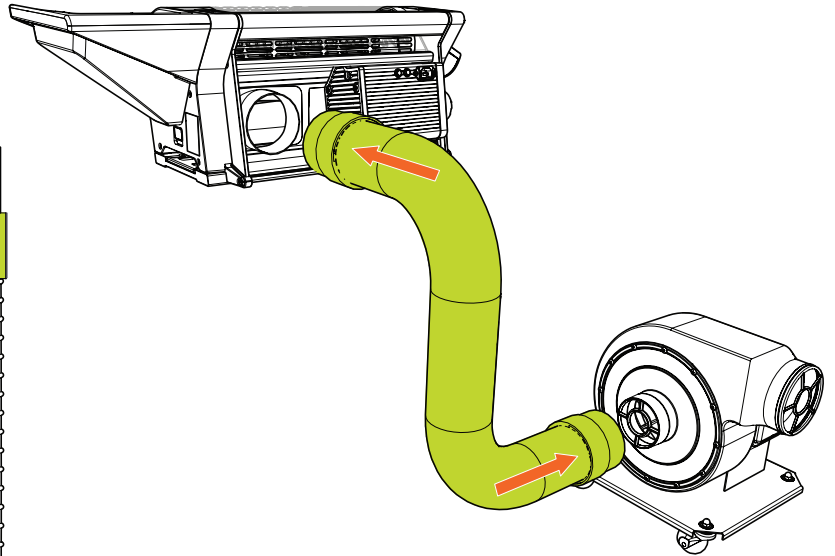
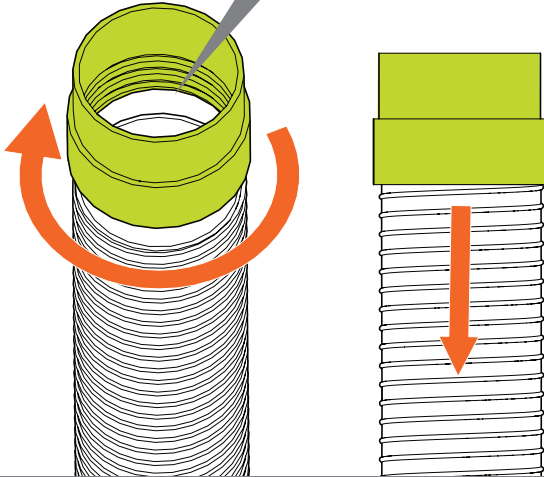

2

INSTALL BLACK BAG FIRST

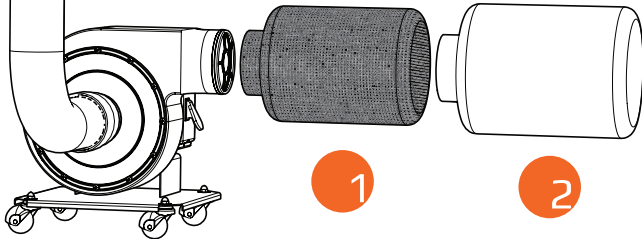

3

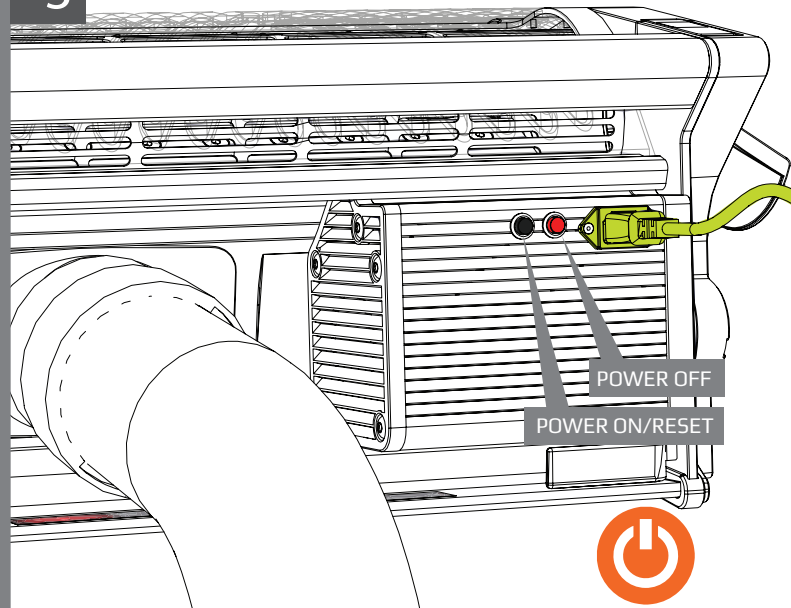

3

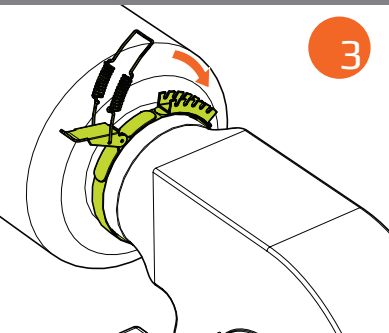

4

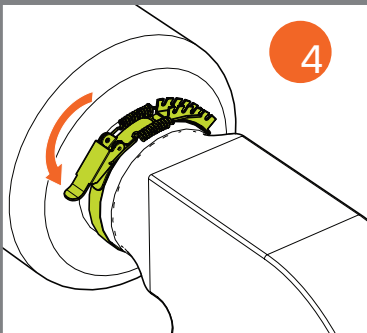

LEG LEVELER

1

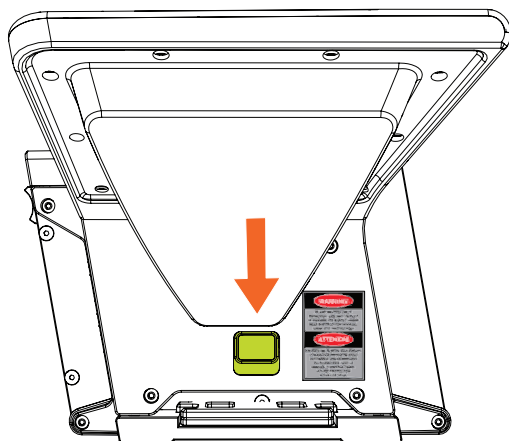

2

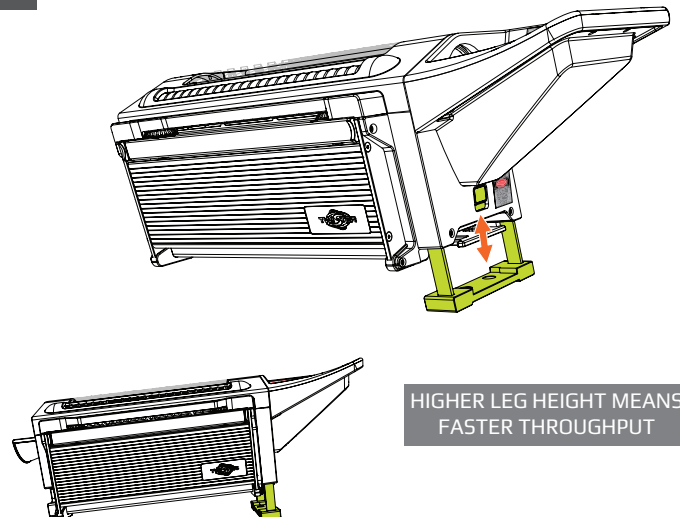

BED KNIFE CLICKER CONTROLS

Light contact between the bed knife and reel blade is normal on a properly adjusted unit. Light contact is indicated by a consistent light to medium ticking sound across the length of the blades. The design allows both blades to receive a continual self-sharpening action. Blade contact is necessary to maintain a sharp cutting edge and prolong the life of this machine. Having no contact will cause the blades to become dull.

1

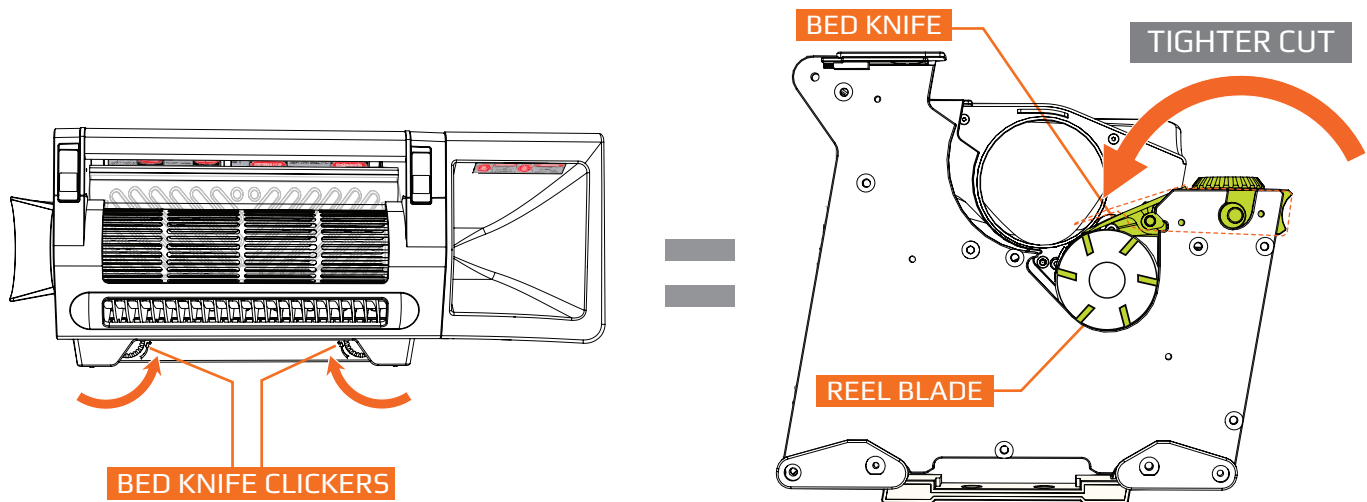

2

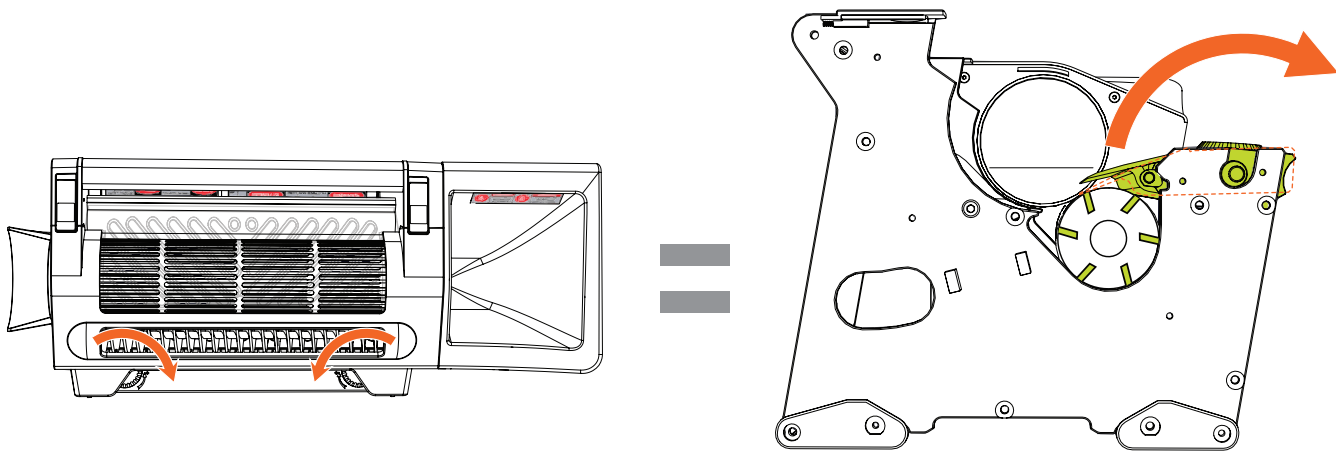

BED KNIFE ADJUSTMENT

The bed knife position has been adjusted and tested by the manufacturer, but it will need adjustments over time. The amount of blade contact is adjusted by rotating the clickers which raise and lower the bed knife. Rotate the clickers towards the "+" for a closer cut and away from the "+" for more clearance. Each clicker will adjust the bed knife position at the point of that clicker. For example, clicking "+" at the hopper end will allow for a closer cut at the hopper end. Care should be taken to ensure both clickers are adjusted evenly to make consistent contact along the length of the bed knife.

To properly align the blades, rotate the clickers away from the "+" until you feel a resistance. This is maximum clearance. Make sure both blades are clean then turn the T6 on (refer to the maintenance section for cleaning instructions). It then takes about two full turns toward the "+" to start making blade contact. Make sure to rotate both clickers simultaneously with each hand.

If contact is made at only one end, indicated by a ticking sound being louder at that end, back the corresponding clicker out by rotating away from the "+". Then rotate the opposite clicker in towards the "+" to even out the bed knife and begin engagement with the reel blade. When one click on each side evenly brings the bed knife into contact with the reel blade, simultaneously rotate both clickers another few clicks closer.

6

TANDEM SETUP

The T6 is designed for quick setup to easily link multiple units for increased throughput.

1 FRONT AND BACK MACHINE

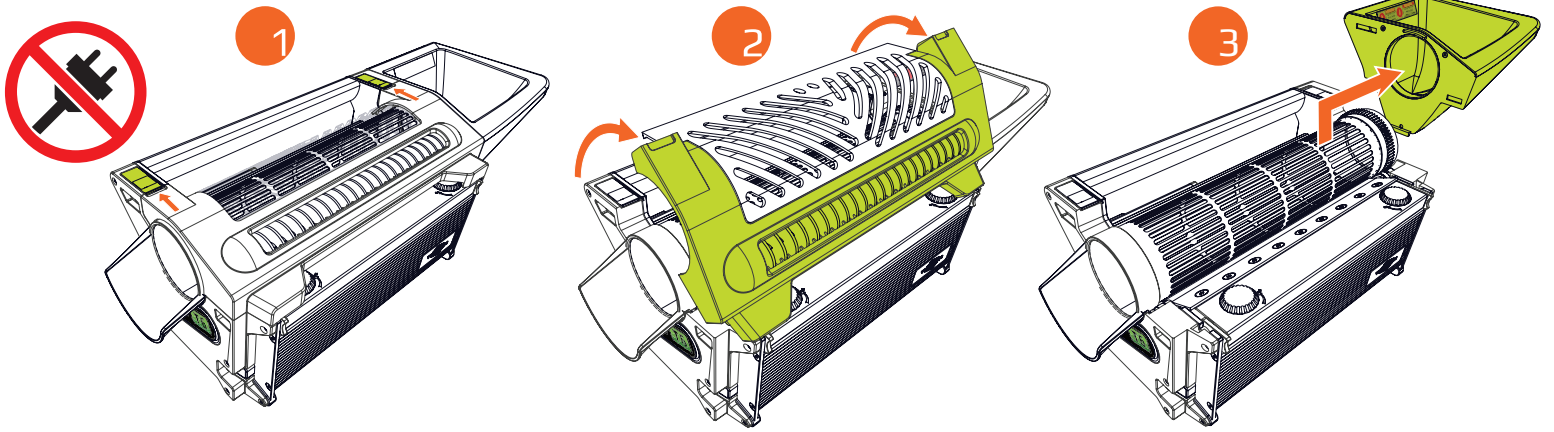

2 BACK MACHINE

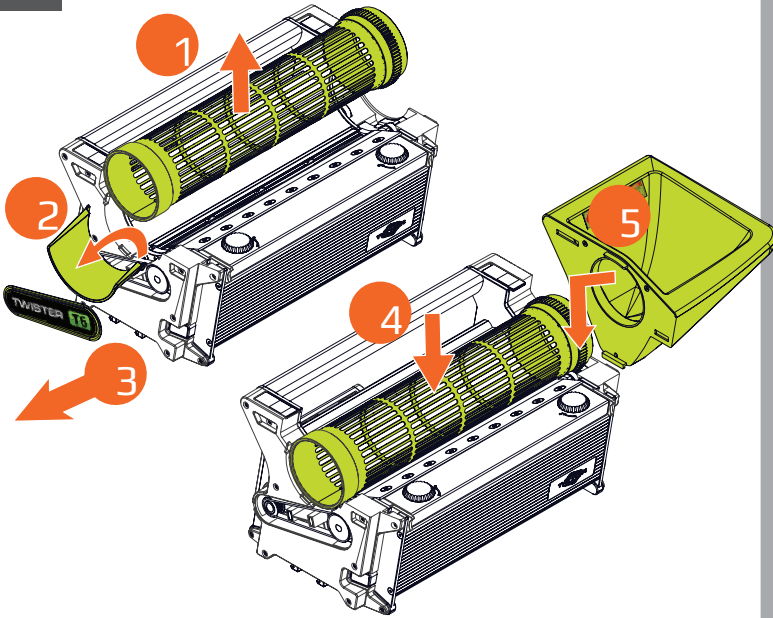

3 BACK MACHINE

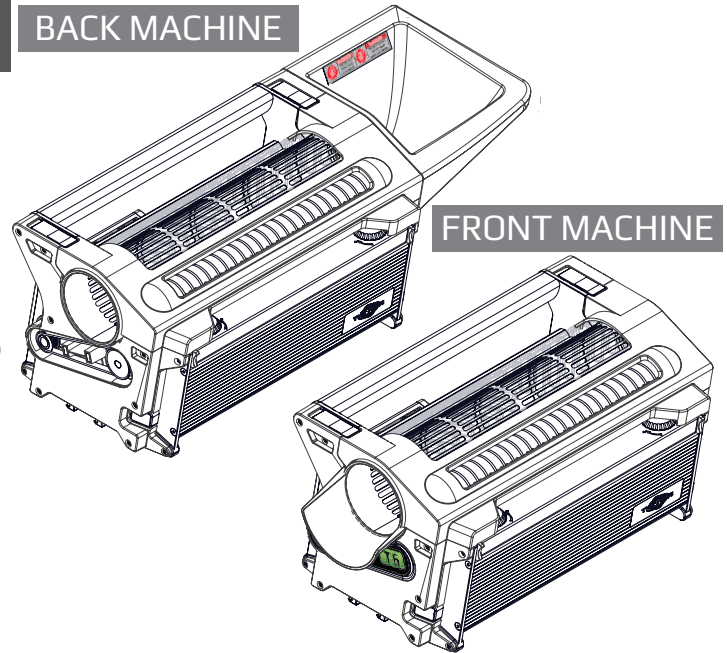

4 FRONT MACHINE

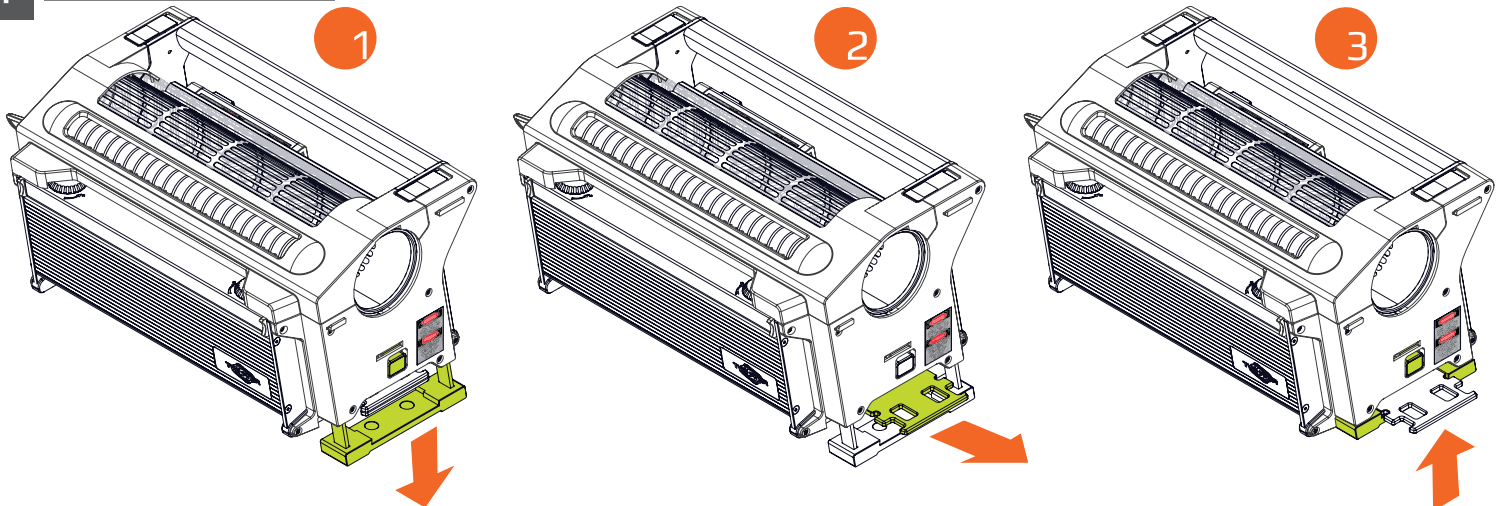

5

BACK MACHINE

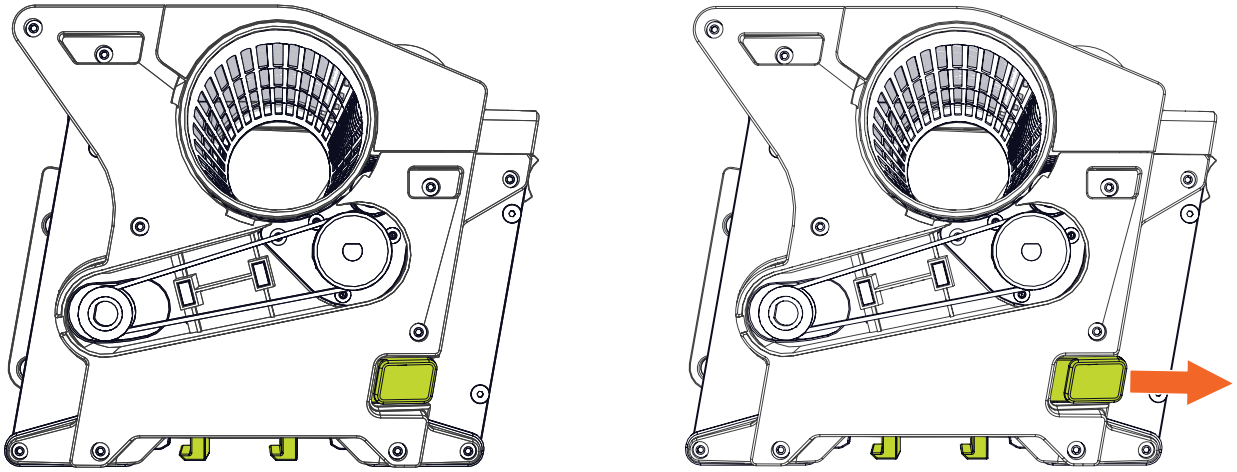

6

FRONT AND BACK MACHINE

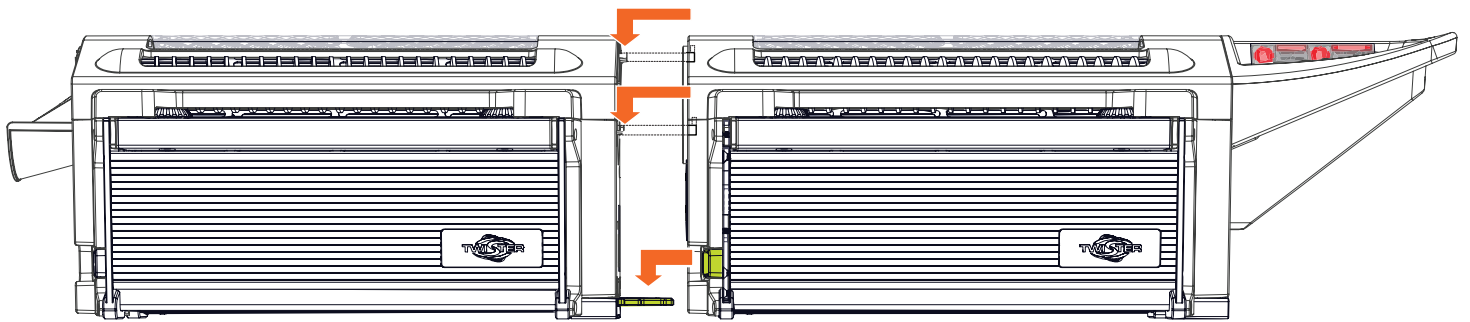

When linking more than two machines, remove the chute, belt cover and hopper from middle machine(s)

7

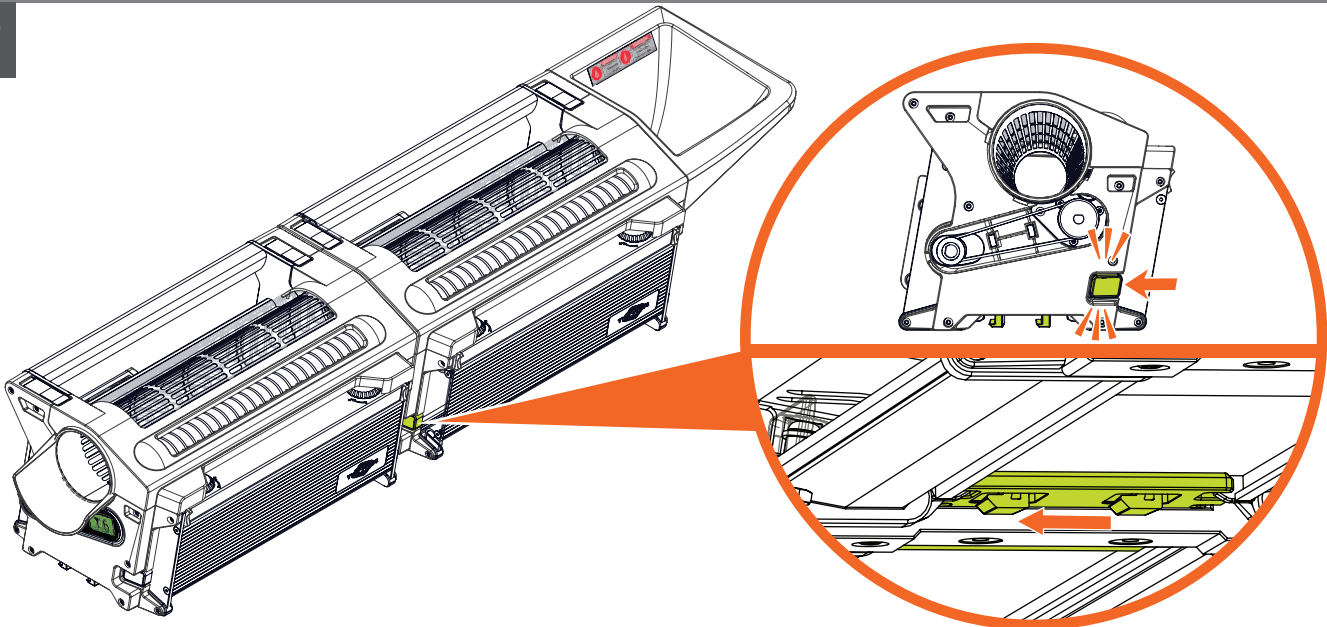

8

TANDEM LEG LEVELER

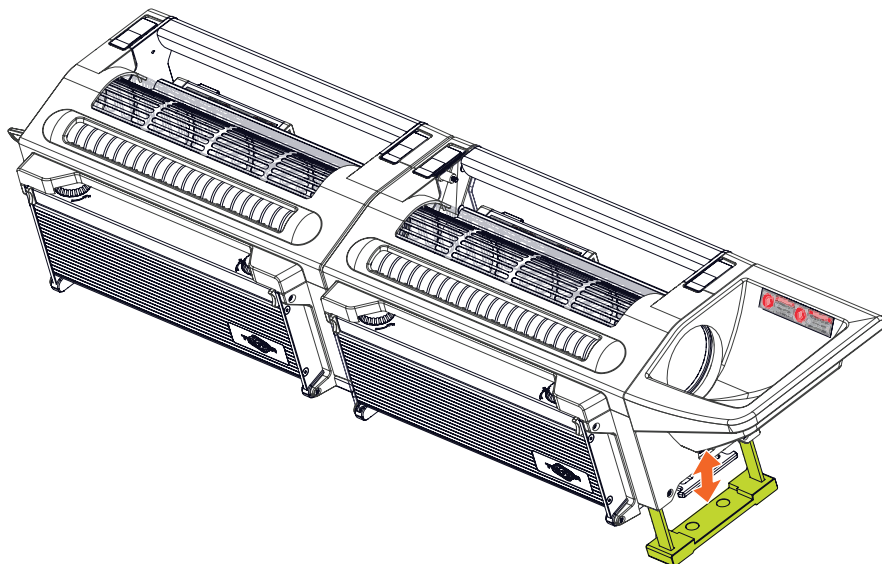
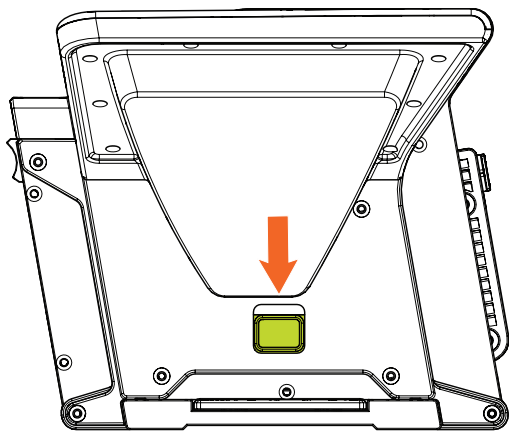

TANDEM DISASSEMBLY

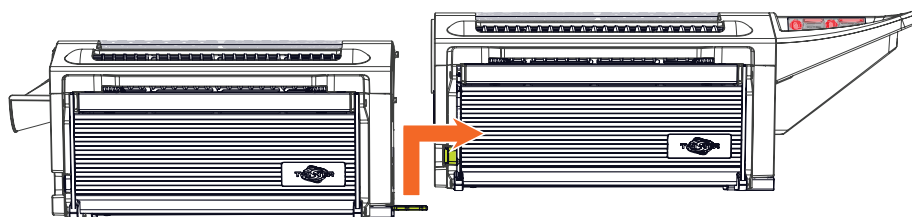
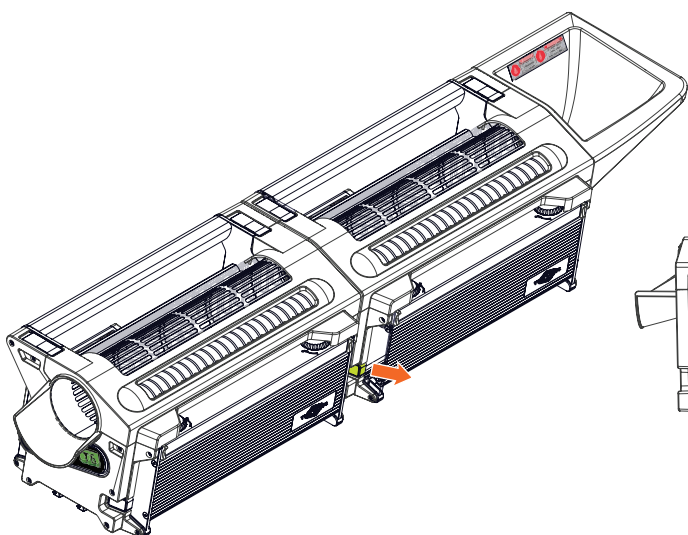

MAINTENANCE

The T6 is a precision machine. It is essential that it is operated and cared for with this in mind. It has been adjusted and tested by the manufacturer for optimal performance. However, at initial startup and at the beginning of each use, it is important to inspect the machine for any damage, plant material buildup and check to ensure the blades spin freely before operating.

It is also highly recommended to clean the machine at the end of every use and to keep the blades lubricated. This will extend the life of the machine and the vacuum components, ensure performance of the machine and make cleanup much easier. This is especially important if the machine is to be stored for extended periods of time. Resins and other plant by-products will build up and harden, becoming difficult to remove.

Although the T6 may be run without lubrication, it is recommended to apply a lubricant such as Clear Cut to the blades of the T6. Lubricant will limit plant material buildup and allow for easy cleaning. A thin coating prior to and after each use, and especially prior to prolonged storage, will extend the life of the cutting surfaces and ensure a smooth startup.

Inspection

Inspection of the T6 should be conducted prior to each use following the upcoming disassembly section and these steps:

- Unplug the T6 and the T6-LC and visually inspect all of the components for wear, damage and plant matter buildup
- Remove the lid, hopper, belt cover, belt and the control box
- Visually inspect the belt for fraying and/or worn teeth
- Inspect the control box pulley and the reel blade pulley for damage and ensure that they are firmly attached
- Visually inspect the tumbler for damage and remove

NOTICE

Be careful when removing the tumbler. This is a delicate precision component of the machine. If dropped or damaged, the machine's performance will be greatly reduced or completely disabled.

- Visually inspect the bed knife for damage and remove
- Rotate the reel blade by spinning the reel blade pulley by hand and ensure that it is able to spin freely
- Visually inspect for the reel blade for damage, looking for any nicks, dents or bends

Damage to the blades is very rare on a properly adjusted machine. Typically rocks, hard metallic objects or poor adjustment is the cause of blade damage. Damage will not be corrected by the self-sharpening feature. These circumstances are not covered under warranty and replacement parts will need to be purchased from an authorized dealer. To avoid these repair costs, please maintain your T6 - keep the bed knife properly adjusted and do not allow objects other than plant material into the tumbler.

Cleaning

A thorough cleaning of the T6 and T6-LC should be performed after each use. Any resin buildup on the machine attracts more resin, compounding the problem. Buildup can cause decreased performance, overheating and could trip your circuit breaker. Future cleaning also becomes more difficult if buildup is given a chance to dry out and harden.

Use only a soft cloth and gentle cleaning solutions on the control box, belt and belt cover. All other components can be simply wiped with isopropyl alcohol or a mild degreaser such as Simple Green. Soaking each component (excluding the control box, belt and belt cover) in hot water will help release the resin. Pay particular attention to the reel blade and the bed knife which should be cleaned at least every 4 hours of operation or more as needed. If the machine was kept adequately lubricated during operation, and has had sufficient amounts of degreaser sprayed on it during pre-soak, then all debris will come off easily.

Any stubborn areas, such as the bed knife and reel blade, may require scrubbing with a stiff bristled plastic brush or a plastic scraper (do not use a metal scraper). Plant matter buildup is the most obvious sign that more attention is needed in a particular area. Such areas are good indicators of the machine needing more lubricant during operation next time or more thorough soaking.

Disconnect the vacuum hose from the T6 and the T6-LC and remove any leaf debris from the vacuum inlet. Remove and empty the leaf collection bags. Remove the screws that hold the inlet on the leaf collector and spray inside the cowling with degreaser to loosen up any built-up plant matter. Scrub the vacuum cowling and impeller with a plastic brush and rinse with cold water. Avoid spraying the control box and motor.

Dry the machine with a soft cloth or compressed air.

DISASSEMBLY INSTRUCTIONS

1

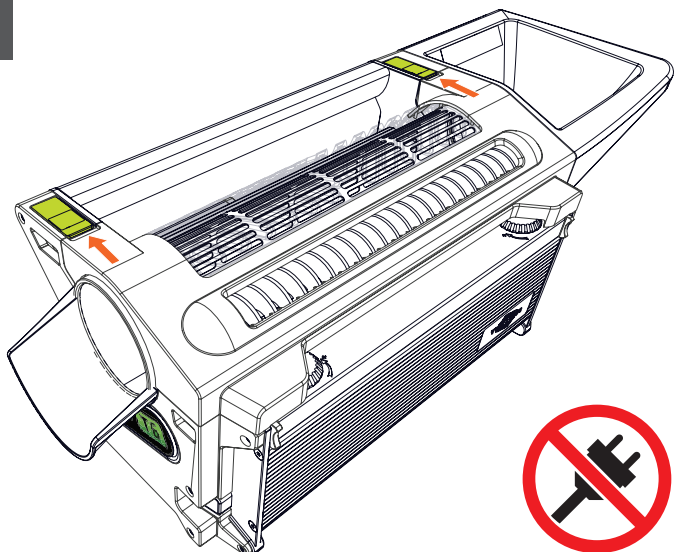

2

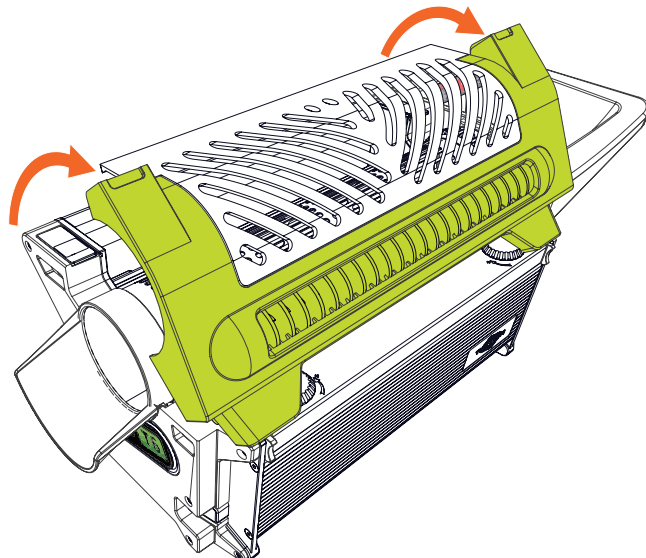

3

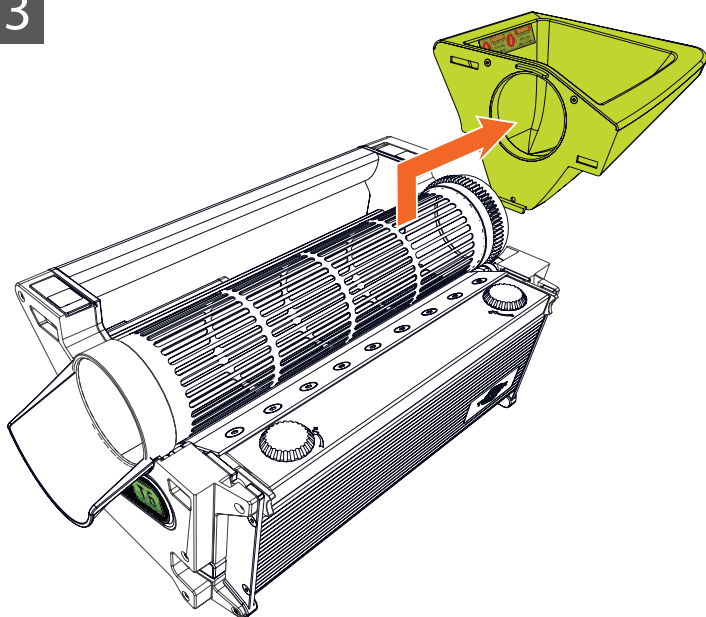

4

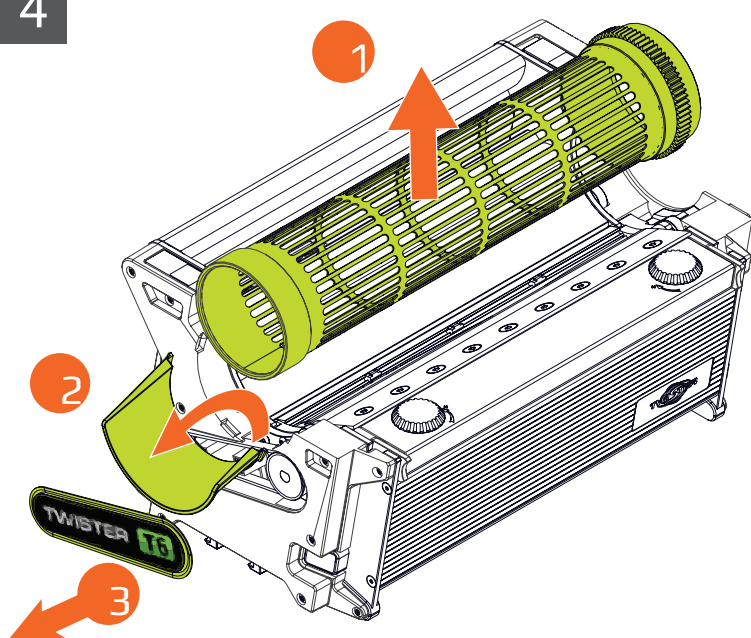

5

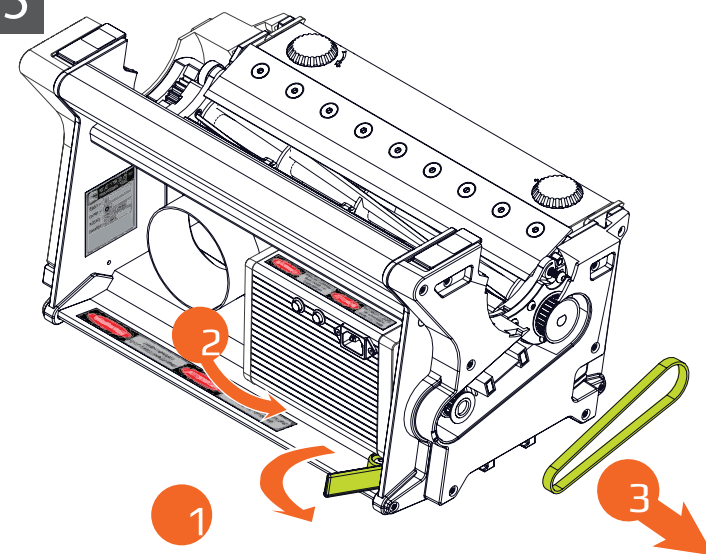

6

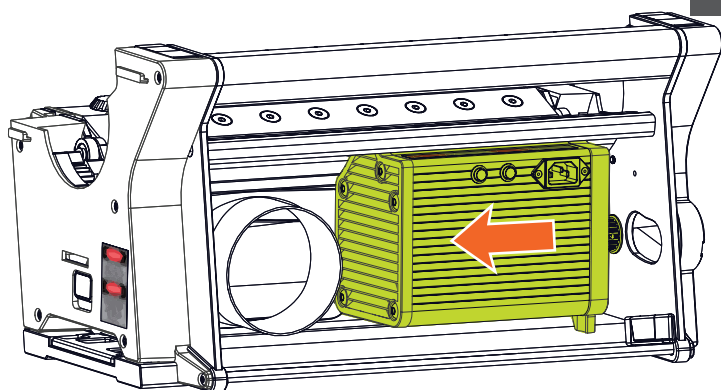

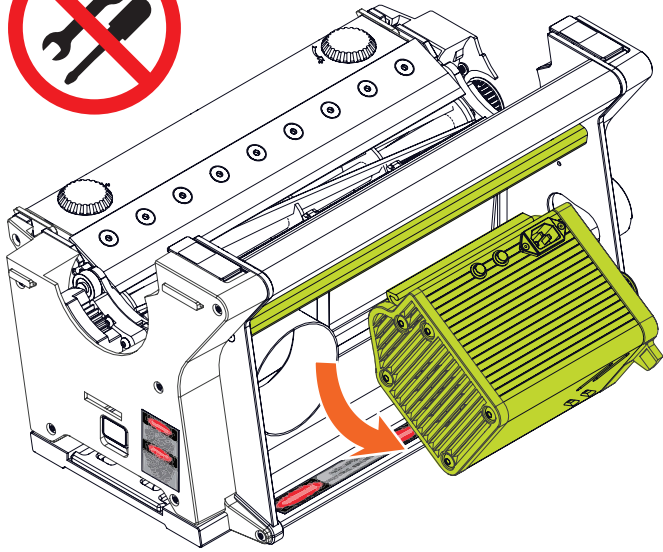

1

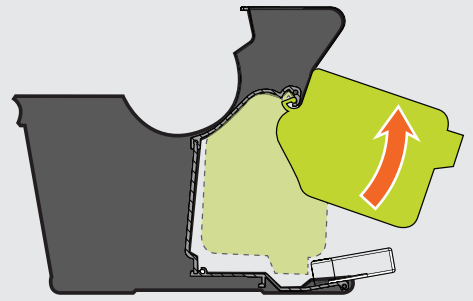

2

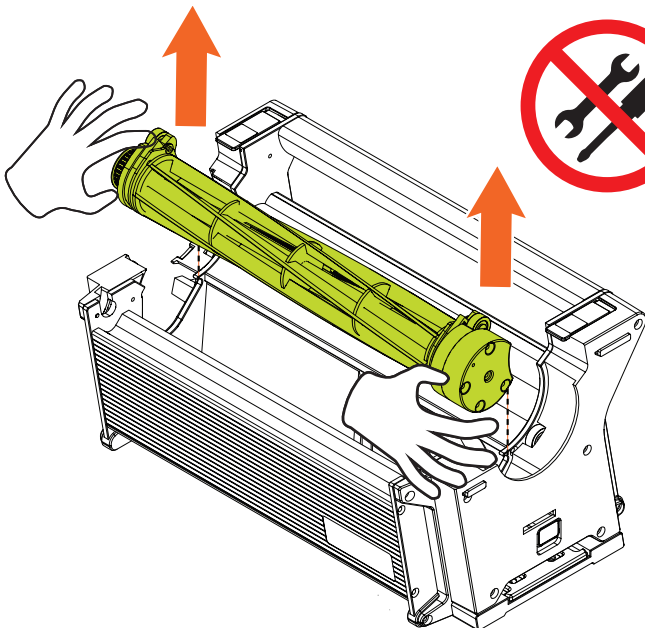
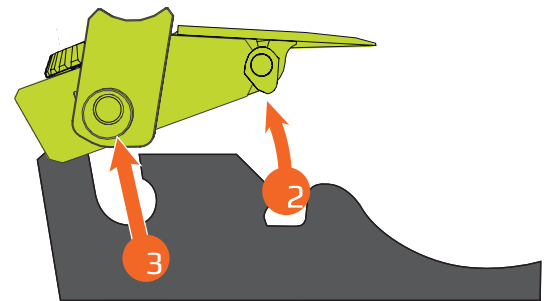
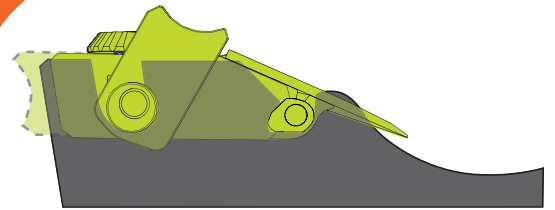
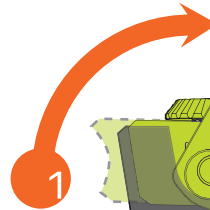
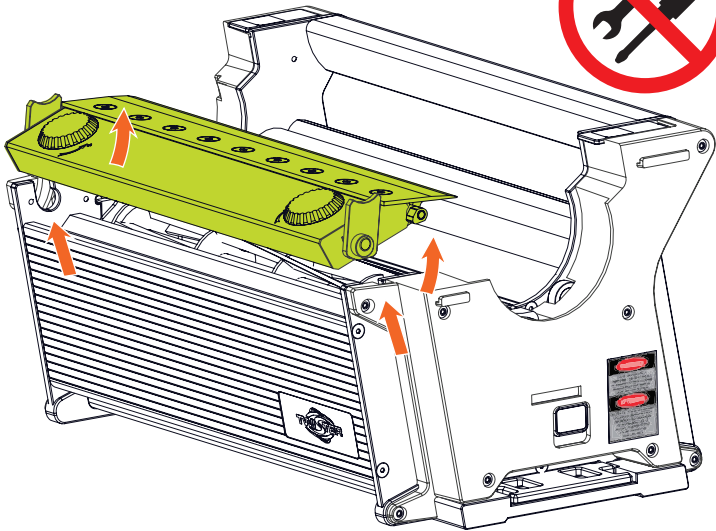
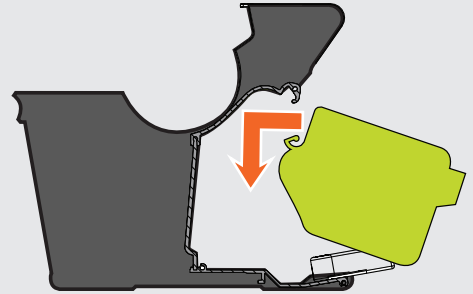

1

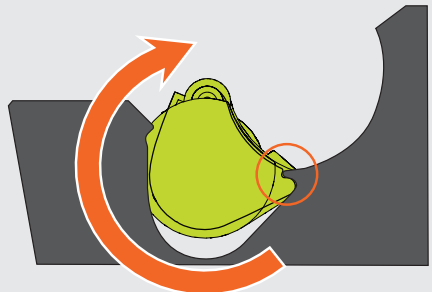

2

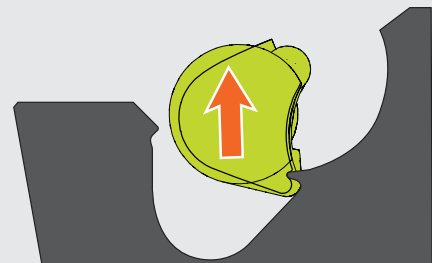

REASSEMBLY INSTRUCTIONS

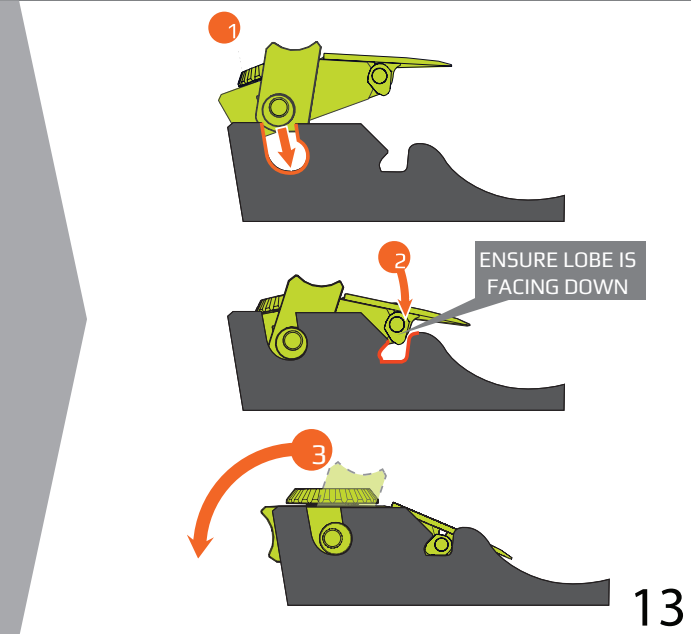
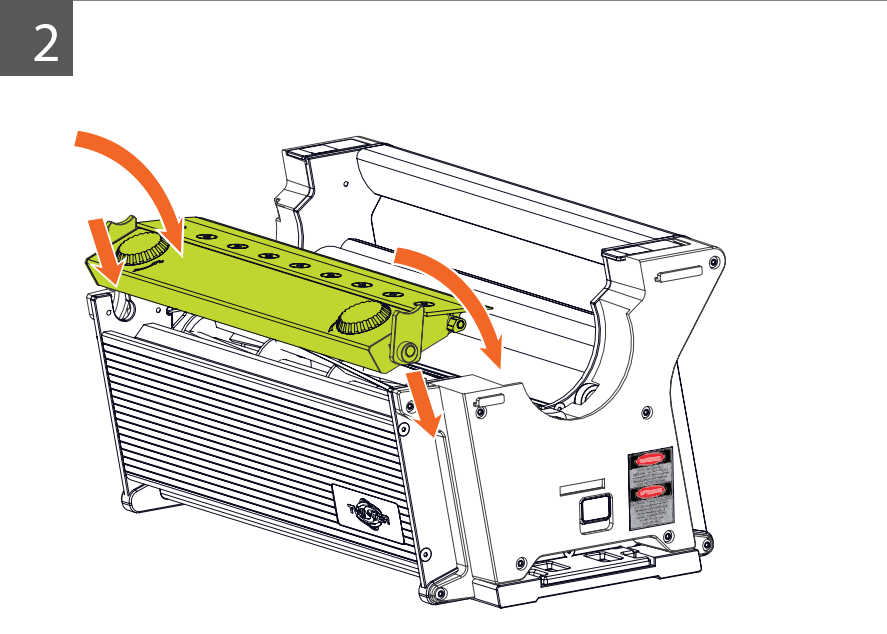
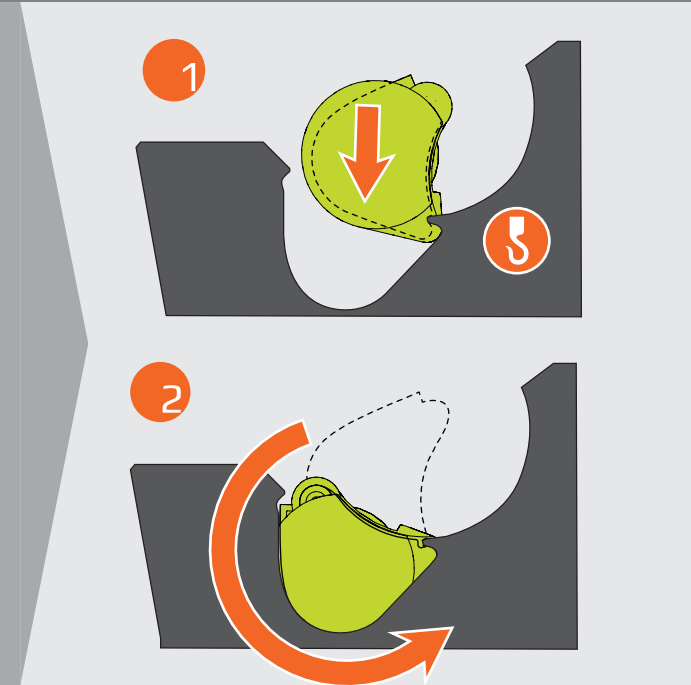
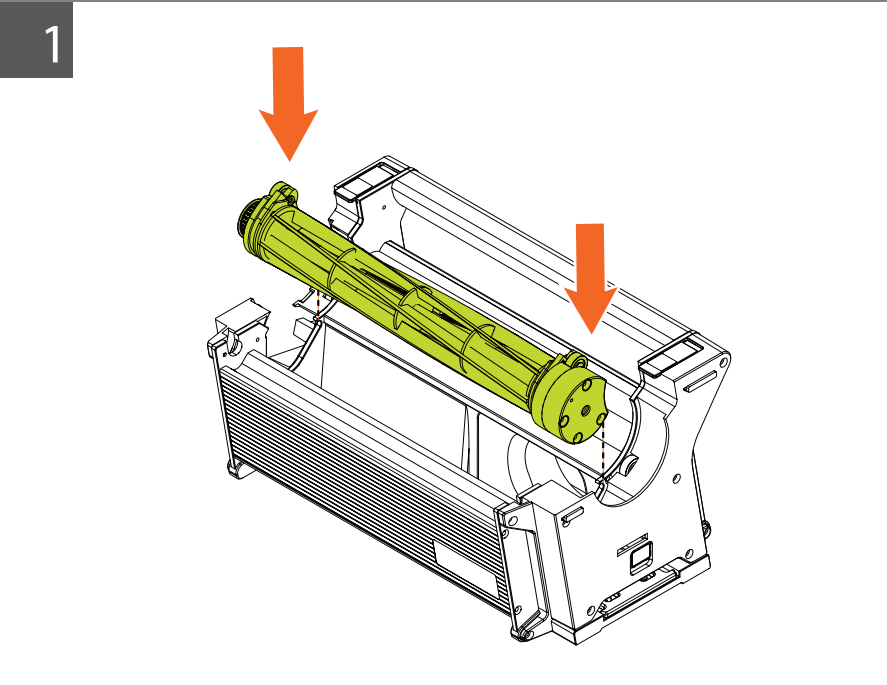
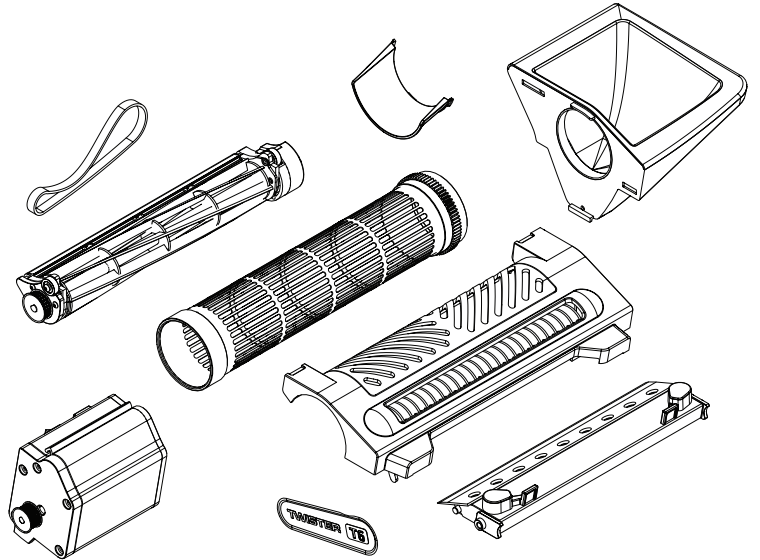
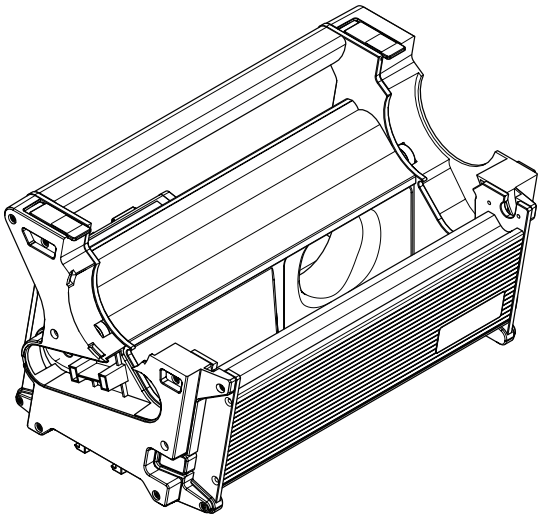

3

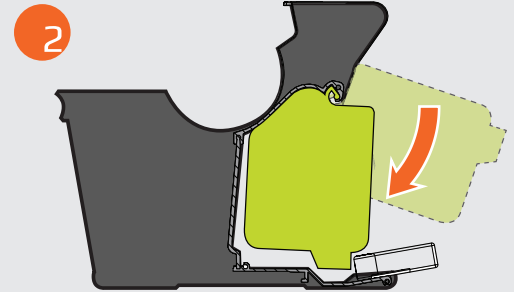
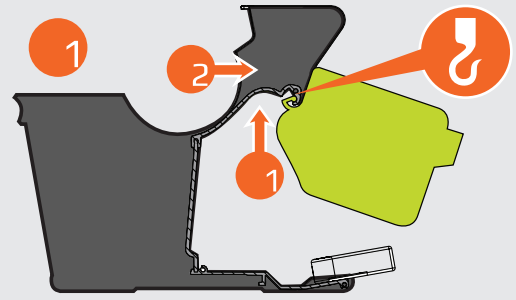
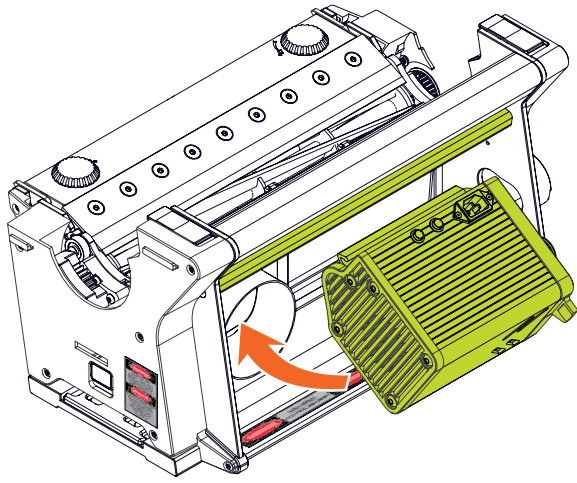

4

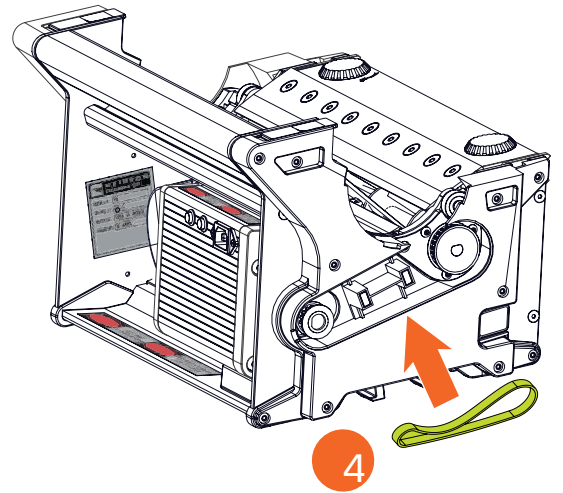
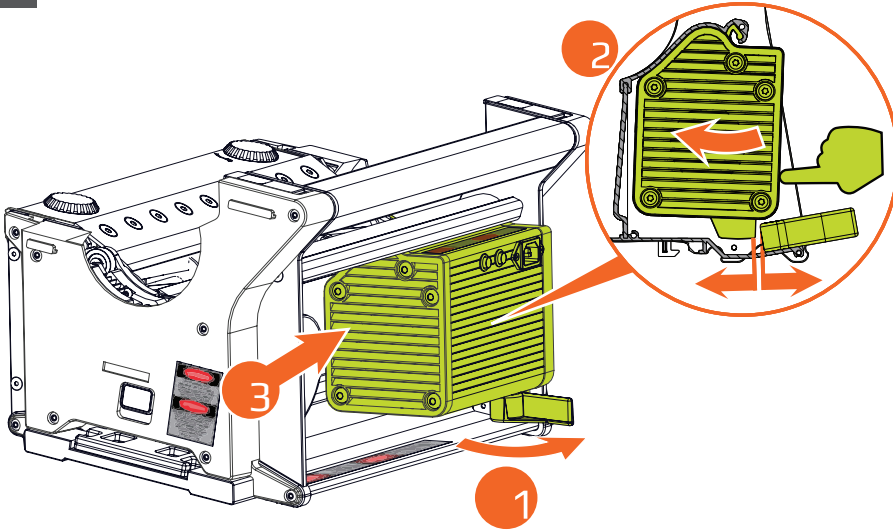

5

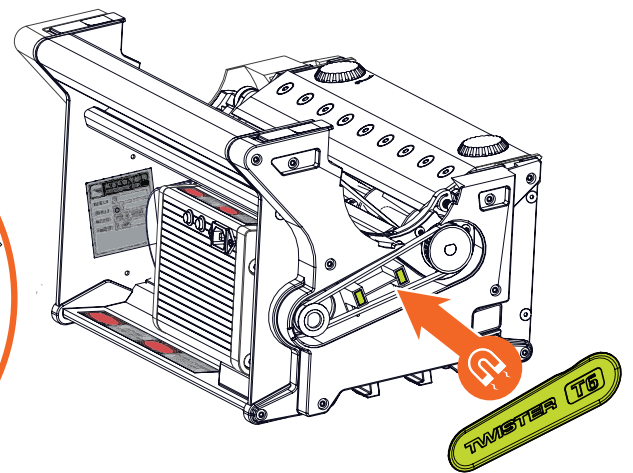
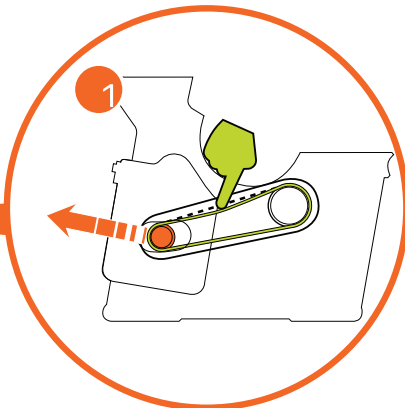
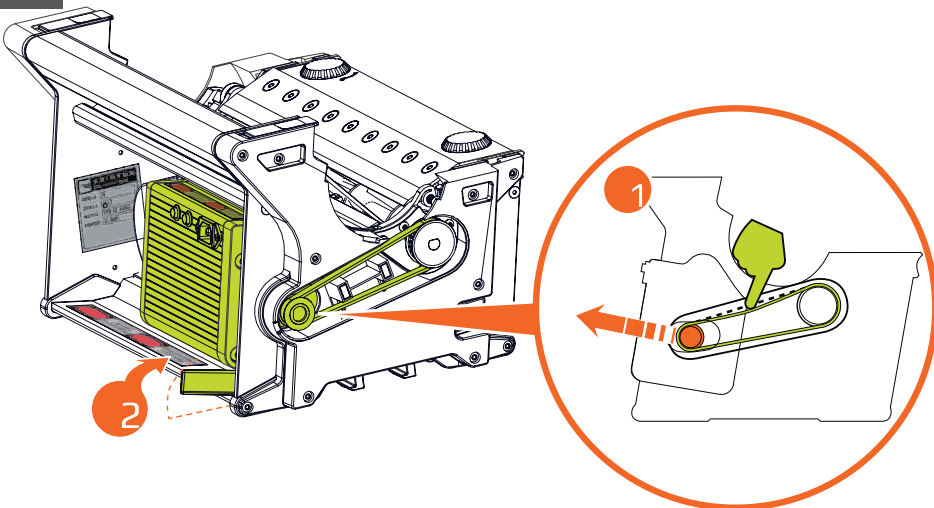

6

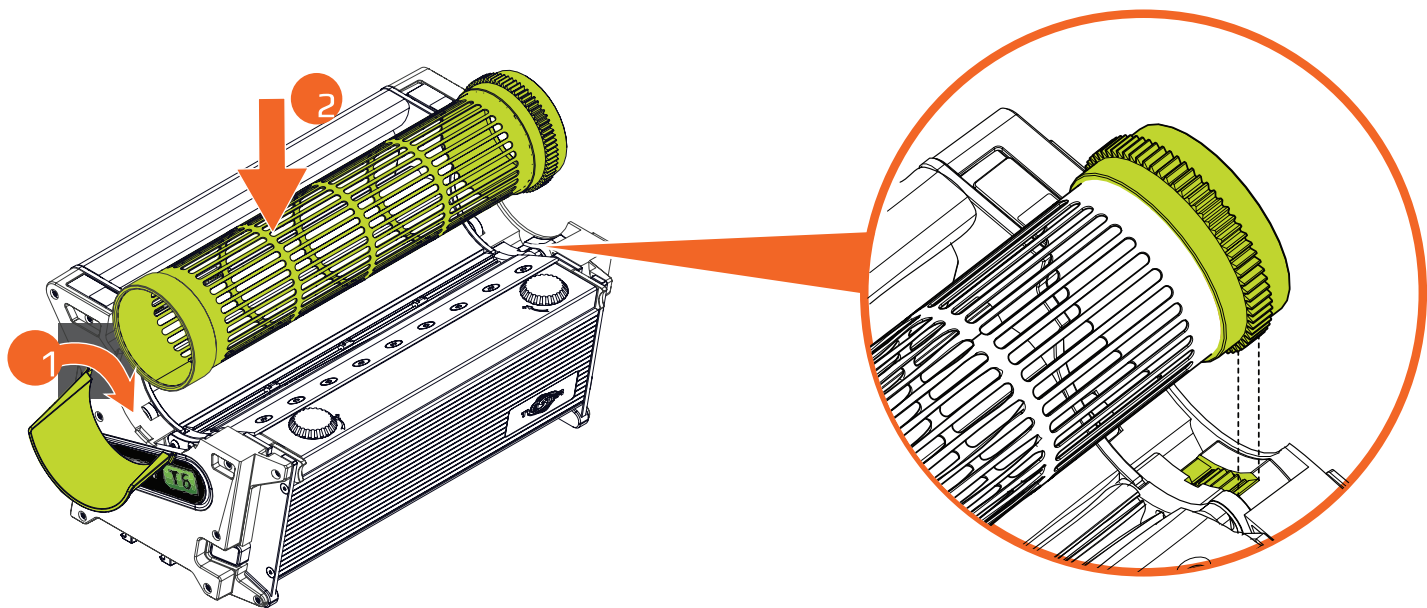

7

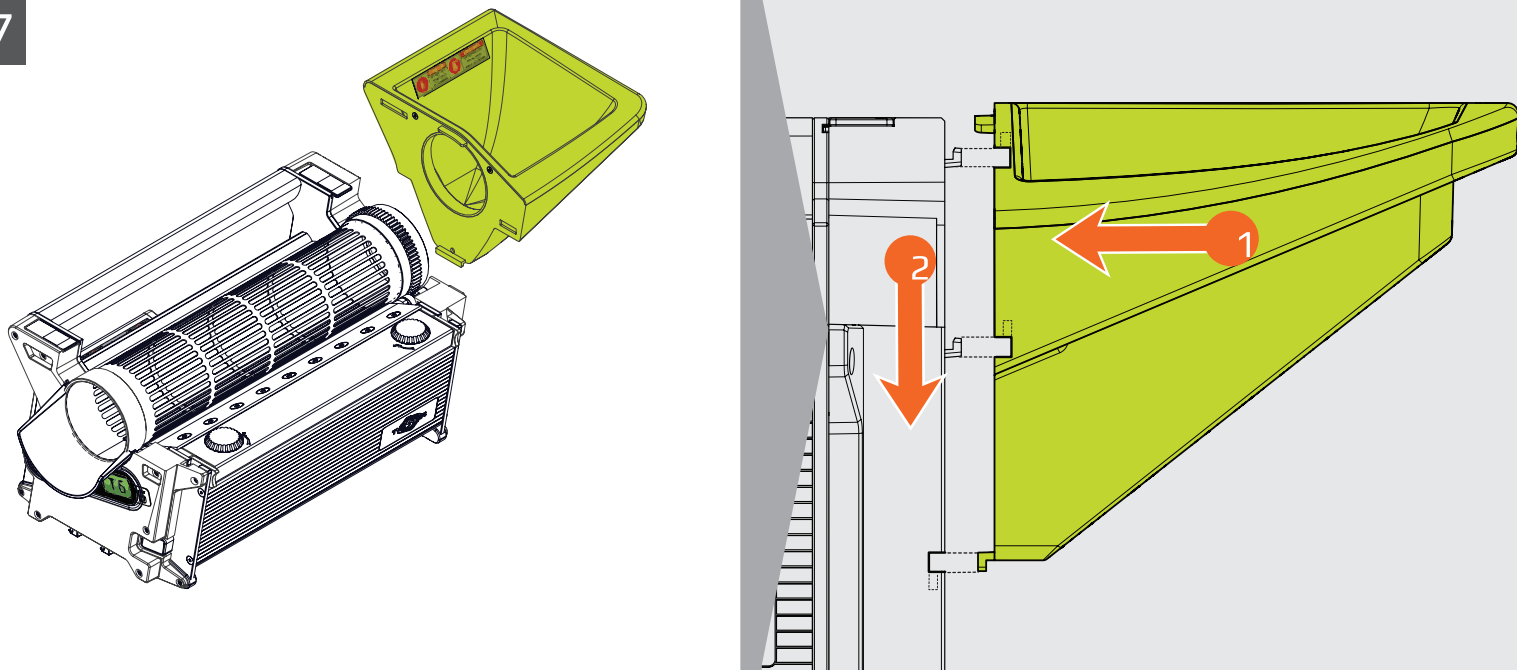

8

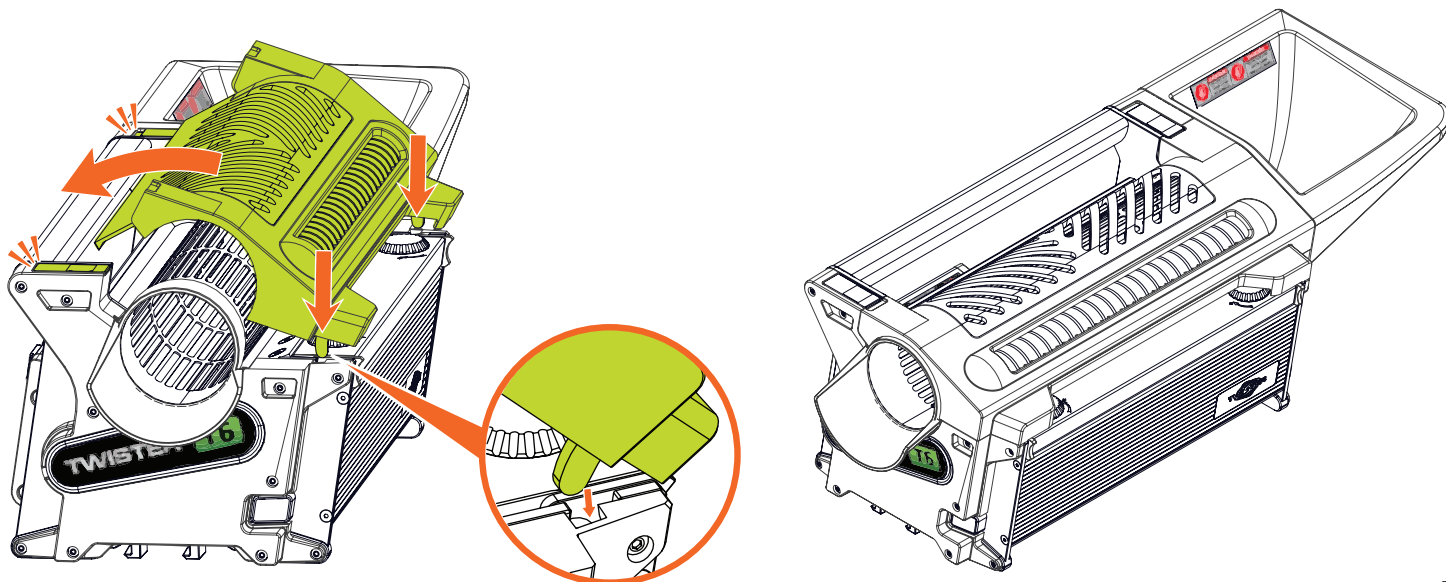

1. **Tumbler makes grinding sound**

Ensure the lid tabs and latches are intact and the tumbler gear is properly engaged. This could be due to damage to the tumbler causing it to rub. This may require a replacement tumbler.

2. **Control box is very hot**

The control box can get very hot if the T6 is run for long periods - this is normal. The motor is thermally protected and will turn off if it becomes too hot.

3. **There is a high pitch squeal coming from the blades**

This can indicate the machine needs bed knife adjustment, cleaning or Clear Cut lubricant. First, raise the bed knife so there is no reel blade contact. If the squeal stops, readjust the bed knife to evenly contact the reel blade. If squeal persists, clean the reel blade and bed knife. Finally, spray Clear Cut lubricant on the blades to stop the squeal.

4. **There is a high speed ticking sound coming from the blades**

This is normal. A ticking sound is the blades making slight contact. This is necessary to maintain the self-sharpening of the blades. If the sound is more than a ticking sound, stop and unplug the machine. Check for adjustment and damage to the blades.

5. **There is a lot of material buildup on the brush, tumbler and blades**

Increase frequency and amount of lubricant applications or clean the machine. If the brush is old, a replacement may be required.

6. **Suction from the T6-LC seems weak**

Ensure there is nothing blocking the vacuum inlet and the filter bags are clean. A clean or new collection bag will keep performance high. Buildup can also accumulate in the leaf collector housing around the impeller, reducing performance. Unplug the leaf collector and remove the inlet housing to clean inside impeller housing.

7. **The material comes out of the machine under-processed**

Ensure all components are on and suction is high. Ensuring the machine is level will keep material in the tumbler and trim for a longer time. Some materials may benefit from a second pass through the machine or slowing the product feed rate.

8. **The tumbler does not spin**

Check the tumbler for obstructions, ensure the lid is correctly installed and make sure the tumbler is placed correctly in and is aligned to the gear.

9. **Bed Knife is difficult to install**

If the green locking tabs are hard to turn, first check the bed knife lobe has the point facing down. If the green tabs are still difficult to turn, back the bed knife clickers away from the "+" until you feel a resistance. Turn the clickers one full rotation towards the "+" and try again.

For all other issues, please call tech support at [1-888-254-3204](tel:1-888-254-3204) or support@keirton.com we will be glad to help you.

Tech support is available from 7am-7pm PST, 7 days a week.

MANUFACTURER'S WARRANTY

The manufacturer will repair or replace, without charge, any parts proven defective in material or workmanship for a period of 3 years.

The warranty period will begin on the date the machine is purchased by the initial purchaser. T6 warranty defects can be remedied at any authorized service dealer or directly at the manufacturer. Any service work performed and deemed valid due to a defective part will be free of charge. Keirton® reserves the right to use any manufacture approved replacement part for warranty repair.

If warranty repair is required, please contact the manufacturer at 1-888-254-3204 or support@keirton.com and provide the following information:

- 1) Model and serial number
- 2) Proof of purchase date
- 3) A copy of the original Warranty Registration Card (unless registration was completed online)
- 4) Details of the defect or problem (including photos/video)

The machine or defective part then must be returned to the manufacturer for analysis and replacement.

Do not return the machine to the place of purchase for repair or warranty claims unless you have been authorized by Keirton to do so. The place of purchase can only sell replacement parts and will not repair warranty issues unless it is noted as an authorized repair dealer and has been authorized to work on your machine.

You may be denied warranty coverage if your machine has failed due to abuse, neglect, improper maintenance, improper electrical connection, normal wear, accidental damage or unapproved modifications.

The manufacturer assumes no risk and shall be subject to no liability for damages or loss resulting from the specific use or application made of the product. In no event will the manufacturer be liable for any special, incidental or consequential damages (including loss of use, loss of profit and claims of third parties) however caused, whether by negligence of the manufacturer or otherwise.

If you have any questions regarding your warranty rights and responsibilities, please contact the manufacturer.

The T6 is intended for use on legal aromatic herbs and hops. Please check all municipal, provincial/state and federal laws and regulations before using the T6. Keirton® does not promote or condone the use of the T6 in any way that may be deemed illegal.



Allow only persons who understand this manual to operate the T6. Keirton® claims no liability for any damage or injury that result from the use of the T6 by persons who have not read and understood the cautions contained in this manual or through any misuse of the T6. You are responsible for your safety while operating this machine - please keep yourself safe!

To receive maximum performance and satisfaction from the T6, it is important that you read and understand the safety and maintenance precautions before using the machine.

ELECTRICAL SPECIFICATION

TWISTER T6	
Input Voltage	115V
Current Draw	2A
Blade Motor	200W / 0.25HP
Cut Height	.040in / 1mm
Discharge	4in / 10.1cm
Weight	42lbs / 19kg
Shipping Weight (w/ T6-LC)	90lbs / 54.4kg
Length	30in / 76.2cm
Width	11in / 27.9cm
Height	10in / 25.4cm
Circuit Breaker Required	15A / 120V
Connector (plug)	NEMA 5-15P
Fused	Yes, Thermally

T6-LC LEAF COLLECTOR	
Input Voltage	115V
Motor	1HP
Amps (running)	7.5A (NA)
Amps (startup)	53A (NA)
Motor Speed	3450RPM
Airflow Capacity	1000 CFM
Static Pressure	6.45in of H2O
Impeller	10in / 25.4cm
Inlet	4in / 10.1cm
Height	15in / 38.1cm
Weight	45lbs / 20.5kg
Circuit Breaker Required	15A / 120V
Connector (plug)	NEMA 5-15P
Sound Rating	94 Db
Fused	Yes, Thermally

	T6-LEAF TRIMMER	T6-LEAF COLLECTOR
Connector (plug)	NEMA 5-15P	NEMA 5-15P
		

Additional Requirements	
Extension Cord	14/3 AWG (minimum AWG size) 15m / 50ft max length

T6 LEAF TRIMMER PARTS LIST

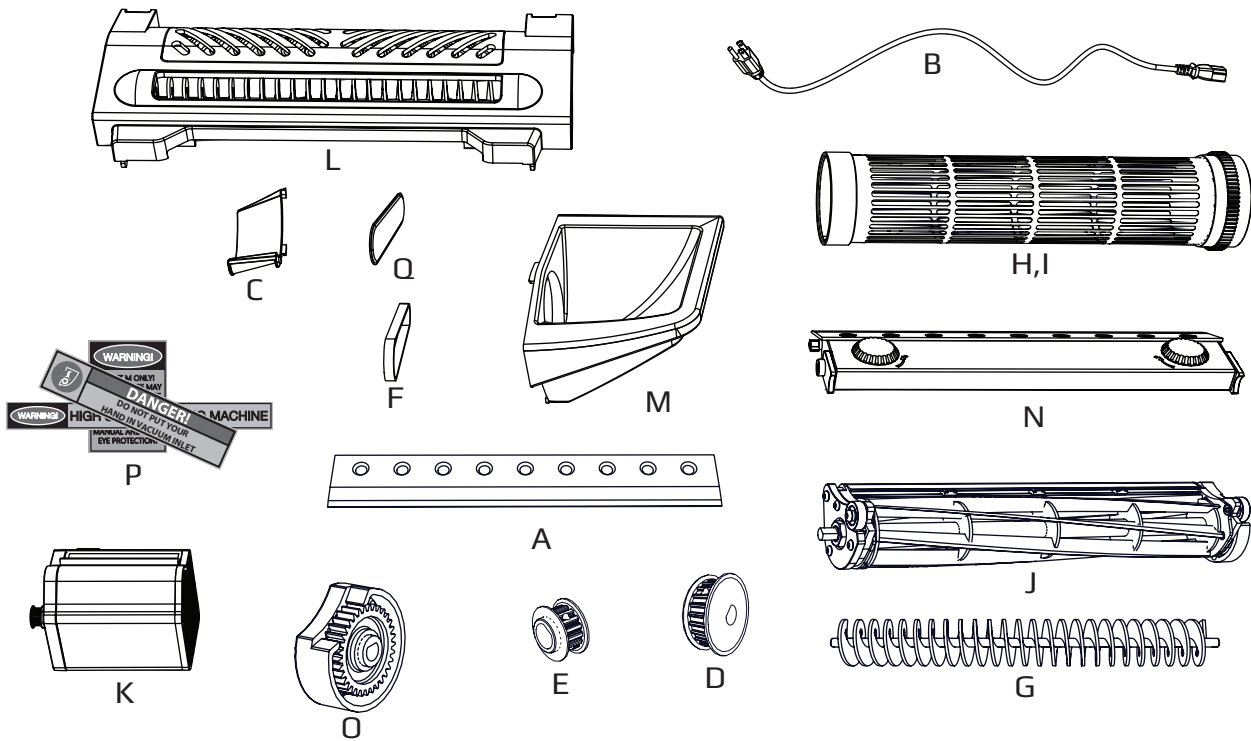

REF	PART NO	DESCRIPTION
A	11-00-000268-P	BED KNIFE (BLADE ONLY)
B	15-01-000286-P	POWER CORD, 6FT LONG
C	17-00-000256-P	CHUTE
D	19-00-000241-P	DRIVE PULLEY, REEL
E	19-00-000296-P	DRIVE PULLEY, MOTOR
F	19-01-000250-P	DRIVE BELT
G	20-00-000308-P	NYLON BRUSH
H	24-02-000216-P	WET TUMBLER ASSEMBLY
I	24-02-000217-P	DRY TUMBLER ASSEMBLY
J	24-02-000242-P	REEL BLADE SUB-ASSEMBLY
K	24-02-000299-P	CONTROL BOX ASSEMBLY
L	24-02-000301-P	LID ASSEMBLY
M	24-02-000309-P	HOPPER ASSEMBLY
N	24-02-000312-P	BED KNIFE ASSEMBLY
O	24-02-000321-P	GEAR BOX ASSEMBLY
P	24-02-000322-P	WARNING DECALS
Q	24-02-000323-P	BELT COVER

