

# MG Master LV 48V 150/400A/600A/1000A

Manual

EN



Version: 1  
Date: 4-4-2017

Copyrights © 2017 MG Energy Systems B.V.  
All Rights Reserved

This publication or parts thereof, may not be reproduced in any form, by any method, for any purpose.

For conditions of use and permission to use this manual for publication in other than the English language, contact MG Energy Systems B.V..

MG ENERGY SYSTEMS B.V. MAKES NO WARRANTY, EITHER EXPRESSED OR IMPLIED, INCLUDING BUT NOT LIMITED TO ANY IMPLIED WARRANTIES OF MERCHANTABILITY OR FITNESS FOR A PARTICULAR PURPOSE, REGARDING THESE MG ENERGY SYSTEMS B.V. PRODUCTS AND MAKES SUCH MG ENERGY SYSTEMS B.V. PRODUCTS AVAILABLE SOLELY ON AN “AS IS” BASIS.

IN NO EVENT SHALL MG ENERGY SYSTEMS B.V. BE LIABLE TO ANYONE FOR SPECIAL, COLLATERAL, INCIDENTAL, OR CONSEQUENTIAL DAMAGES IN CONNECTION WITH OR ARISING OUT OF PURCHASE OR USE OF THESE MG ENERGY SYSTEMS B.V. PRODUCTS. THE SOLE AND EXCLUSIVE LIABILITY TO MG ENERGY SYSTEMS B.V., REGARDLESS OF THE FORM OF ACTION, SHALL NOT EXCEED THE PURCHASE PRICE OF THE MG ENERGY SYSTEMS B.V. PRODUCTS DESCRIBED HERE IN.

MG Energy Systems B.V.. reserves the right to revise and improve its products as it sees fit. This publication describes the state of this product at the time of its publication and may not reflect the product at all times in the future.

## TABLE OF CONTENTS

1.	SAFETY INSTRUCTIONS.....	5
1.1	In general .....	5
1.2	Installation .....	5
1.3	Transport and storage.....	6
1.3.1	General storage instructions of Lithium-ion batteries.....	6
1.3.2	Storage instructions of a complete system (Lithium-ion batteries with MG Master LV)6	6
2	DESCRIPTION.....	7
2.1	System components.....	7
2.1.1	Battery Management System .....	7
2.1.2	Safety .....	7
3	INSTALLATION.....	8
3.1	Safety precautions .....	8
3.2	Location.....	8
3.3	Mounting.....	8
3.4	Connecting the battery system.....	9
3.4.1	Connecting the battery power connections .....	9
3.4.2	Installing Fuses.....	9
3.4.3	Parallel connection of batteries.....	10
3.4.4	Series connection of batteries .....	11
3.4.5	Connecting the BMS CAN-Bus network .....	11
3.4.6	Connecting to NMEA2000 network .....	12
3.4.7	Connecting the Allow-to-charge and Allow-to-discharge.....	13
3.4.8	External status output.....	13
3.4.9	External START-button.....	14
3.4.10	Auxiliary power output .....	15
3.4.11	Programmable contact .....	15
4	FIRST POWER UP.....	16
4.1	Power up procedure .....	16
4.2	Power down/reset procedure.....	16
4.3	Automatic power-up.....	16
5	CONNECTING A VICTRON MULTI OR QUATTRO .....	17
5.1	Connection of a Victron Energy Multi or Quattro inverter/charger .....	17
5.2	Connecting the allow-to-charge and allow-to-discharge .....	17

5.2.1	Connecting 1 Multi or Quattro.....	17
5.2.2	Connecting 2 or more Multi's or Quattro's.....	18
5.3	Configuration of a Multi or Quattro.....	19
6	CHARGER SETTINGS .....	21
7	UPDATING FIRMWARE.....	22
7.1	Updating procedure.....	22
7.2	Connecting a CAN to USB Interface .....	22
8	COMMISSIONING .....	23
8.1	Procedure.....	23
9	LED INDICATIONS .....	24
10	MAINTANANCE .....	25
11	TECHNICAL SPECIFICATIONS .....	26
11.1	MG Master LV 48V 150A/400A/600A/1000A .....	26
APPENDIX A: Connection overview of the MG Master LV .....		27
APPENDIX B: Inside the MG Master LV .....		28
APPENDIX C: Dimensions .....		29

## 1. SAFETY INSTRUCTIONS

### 1.1 In general

Please read the documentation supplied with this product first, so that you are familiar with the safety signs and directions before using the product.

This product is designed and tested in accordance with international standards. The equipment should be used for the designated application only.



**WARNING: DANGER OF ELECTRICAL SHOCK**

The product is used in combination with a permanent energy source (battery). Even if the equipment is switched off.

The product contains no internal user-serviceable parts. Do not remove the front panel and do not put the product into operation unless all panels are fitted. All maintenance should be performed by qualified personnel.

Never use the product at sites where gas or dust explosions could occur. Refer to the specifications provided by the manufacturer of the battery to ensure that the battery is suitable for use with this product. The battery manufacturer's safety instructions should always be observed.



**WARNING: do not lift heavy objects unassisted.**

### 1.2 Installation

Read the installation instructions before commencing installation activities.

- Ensure that the connection cables are provided with fuses and circuit breakers. Never replace a protective device by a component of a different type. Refer to the manual or contact manufacturer for the correct part.
- Check before switching the device on whether the available voltage source conforms to the configuration settings of the product as described in the manual.
- Ensure that the equipment is used under the correct operating conditions. Never operate it in a wet or dusty environment.
- Ensure that there is always sufficient free space around the product for ventilation, and that ventilation openings are not blocked.
- Install the product in a heatproof environment. Ensure therefore that there are no chemicals, plastic parts, curtains or other textiles, etc. in the immediate vicinity of the equipment.

### 1.3 Transport and storage

On storage or transport of the product, ensure that the battery leads are disconnected.

No liability can be accepted for damage in transit if the equipment is not transported in its original packaging.

Store the product in a dry environment; the storage temperature should range from  $-20^{\circ}\text{C}$  to  $55^{\circ}\text{C}$ .

#### 1.3.1 General storage instructions of Lithium-ion batteries

The best way to store Lithium-ion batteries is at a State-Of-Charge (SOC) of 60%.

Check the voltage of the stored Lithium-ion battery periodically. If the voltage is dropped below the cut off level, recharge it. The battery management system (BMS) electronics have always a leakage current which will eventually empty the battery. The weekly consumption of the BMS inside a MG Lithium-ion battery, when not connected to the MG Master LV, is approximately  $<2\text{Wh}$ .

#### 1.3.2 Storage instructions of a complete system (Lithium-ion batteries with MG Master LV)

Lithium-ion batteries will permanently damage when fully drained. The system has a small self-discharge which needs to be taken into account when storing the system.

When storing a complete system, make sure that the MG Master LV is set in standby mode (for instructions see chapter 5.2).

- Standby consumption 24V Systems: 75mW for the MG Master LV (standby).
- Standby consumption 48V systems: 145mW for the MG Master LV (standby).

#### *Two calculation examples:*

- A full single 24Volt battery connected to a MG Master LV which is in standby will last approximately **2570 days**. The same system, but then automatically switched to standby mode due to under voltage will last approximately **128 days**.
- A full 48Volt system with two batteries in series, connected to a MG Master LV which is in standby will last approximately **2700 days**. The same system which has automatically disconnected and switched to standby mode due to under voltage will last approximately **135 days**.

## 2 DESCRIPTION

Key features of the MG Lithium-Ion battery system.

- Easy installation and usage;
- Integrated safety contactor used as second level protection;
- Active and passive balancing control capabilities (depending on connected battery module);
- Separate CAN-Bus between USER and BMS CAN-Bus network;
- I/O interface for connection with different chargers and loads;

### 2.1 System components

- One or more **MG Lithium-Ion LFP, NMC or HE battery modules**;
- One or more modular DC power **Distributor** for use at the battery side of the system;
- The **MG Master LV** is the battery management system (BMS) that controls and monitors the batteries. A 150A/400A/600A/1000A safety contactor is inside.
- One or more modular DC power **Distributor** for use at the charger/load side of the system;
- Optionally a **Victron Color Control GX** can be used as a control panel.

#### 2.1.1 Battery Management System

Each battery module comes with an integrated battery management system (BMS). This is an intelligent electronic module (slave BMS) that measures all cell voltages, temperatures and controls the balancing. Each slave BMS has an intelligent balancing system that allows balancing on battery cell and module level. The battery modules communicate by CAN-Bus with the MG Master LV (master BMS). The status of the battery modules are collected and monitored. If the measured values from a battery module exceeds the limit, the MG Master LV will automatically takes action to protect the connected battery modules.

#### 2.1.2 Safety

The MG Master LV is the safety and control unit of the system. It protects the connected battery modules against over-charging, over-discharging, over-temperature and under-temperature. The MG Master LV also takes care of the balancing on battery cell and module level. In order to guarantee a safe operation of the system, a safety contactor is implemented that can disconnect the batteries from the chargers and loads when necessary.

### 3 INSTALLATION



This product may only be installed by a qualified electrical engineer.

#### 3.1 Safety precautions



1. Be careful when using metal tools in vicinity of batteries. Dropping a metal tool onto a battery might cause a short-circuit and possibly an explosion.
2. Always use isolated tools when working with batteries.
3. Remove personal metal items such as rings, bracelets, necklaces, and watches when working with a battery. A battery can produce a short-circuit current high enough to melt such items, leading to severe burns.

#### 3.2 Location

The product must be installed in a dry and well-ventilated area, as close as possible to the batteries.



**Excessively high ambient temperature will result in a reduced battery lifetime.**

The interior of the system components must remain easily accessible after installation.

Try and keep the distance between the components and the battery to a minimum in order to minimize cable voltage losses.



For safety purposes, this product should be installed in a heat-resistant environment. You should prevent the presence of e.g. chemicals, synthetic components, curtains or other textiles, etc., in the immediate vicinity.

#### 3.3 Mounting

The MG Master LV must be mounted on a wall. See Appendix B for mounting details.



### 3.4 Connecting the battery system

#### 3.4.1 Connecting the battery power connections

##### Procedure

1. First remove the front of the MG Master LV.
2. Mount the system to the wall.
3. Connect all chargers and loads to the right side of the MG Master LV.
4. Connect all the batteries to the left side of the MG Master LV.



If multiple batteries are connected in parallel they can be fused individually on the battery side (left side) of the MG Master LV.

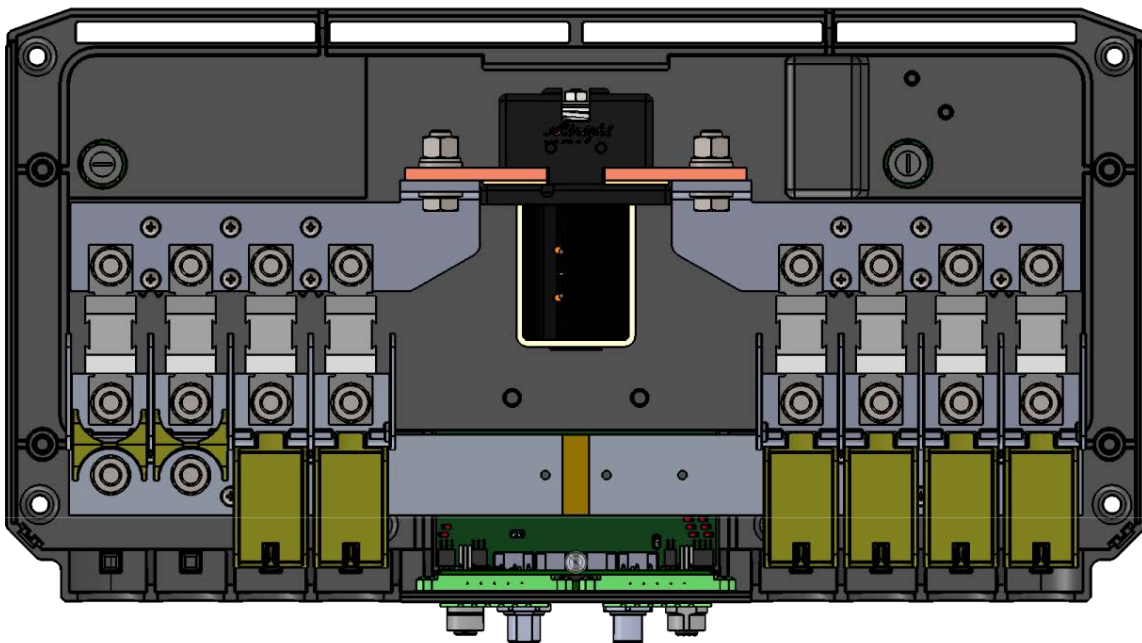

**WARNING:** Never connect loads and chargers directly to the batteries. This can damage the batteries.

#### 3.4.2 Installing Fuses

Fuses must be installed on both the battery side and load/charger side of the MG Master LV.



The total value of the fuses in the Distributor on the load/charger side (right side) may not exceed the maximum current of the safety contactor (an equal load ratio can be added depending on the application). For the MG Master LV 400 this is 400 A and for the MG Master LV 600 this is 600 A.

On the battery side (left), the fuses are functional as short-circuit protection. It is recommended that this value is between 300 A and 500 A on each connection depending on how many batteries are connected.

Possible fuses:

Fuse type	Voltage
MEGA Fuse 32V BF2 fuse (little fuse)	32V: Used for 24V systems
MEGA Fuse 58V BF2 fuse (little fuse)	58V: Used for 48V systems
FWA 150V (Bussmann)	150V: Used for systems up to 150V (the MG Master LV can handle voltages up to 60V max. For higher voltage contact the manufacturer.)

### 3.4.3 Parallel connection of batteries

- Be sure that the battery state-of-charge (SOC) is equal for each battery. If the batteries are new then they have an equal state-of-charge (SOC is 30%).
- Keep wire lengths exactly the same. Otherwise imbalance occurs.

Batteries can be connected to the Distributor or as a parallel battery string like in the figure below.

Example of parallel connection of batteries with the same cable lengths:

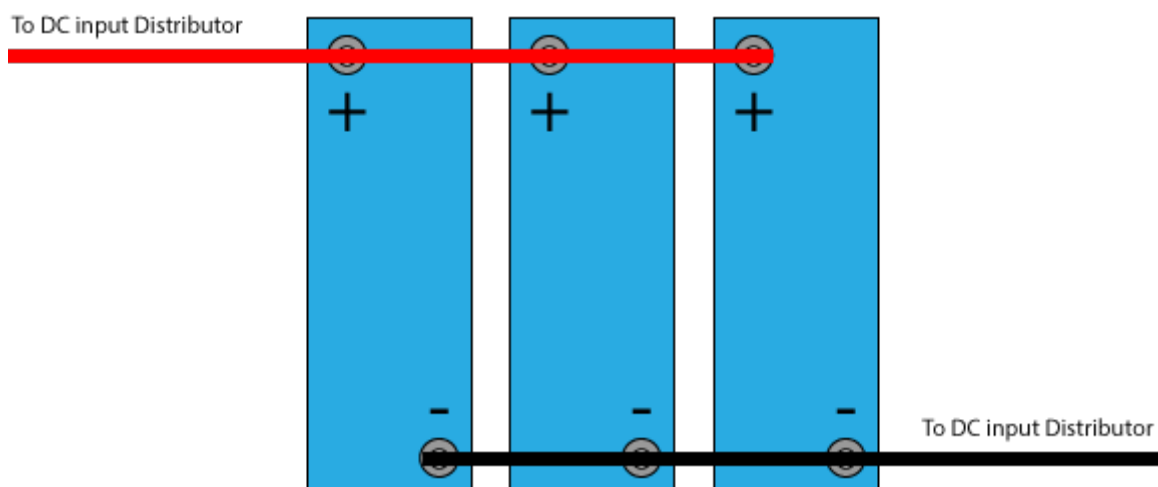

**Above solution can be used up to 5 batteries maximum.**

### 3.4.4 Series connection of batteries

The maximum battery in series is 2. This is because the standard maximum input voltage of the MG Master LV is 60 VDC.

- Be sure that the battery state-of-charge is equal for each battery. If the batteries are new then they have an equal state-of-charge.

Example of series connection of two batteries:

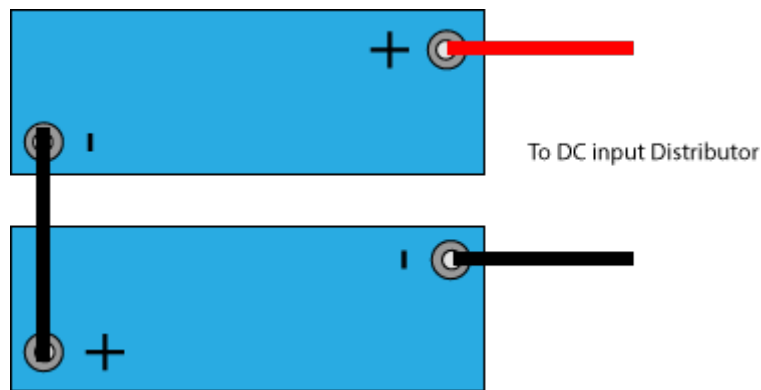

### 3.4.5 Connecting the BMS CAN-Bus network

To connect the BMS CAN-Bus communication network you will need:

- CAT5 cable with RJ45 connectors (straight wiring);
- Two termination resistors (supplied with the MG Master LV);

#### Procedure

1. Connect the RJ45 cable between the BMS CAN-Bus connection of the MG Master LV (see appendix A for details) and the first battery.
2. Then connect it to the second battery (if there is one) with the next RJ45 cable.
3. Repeat this until all batteries are connected.
4. Place a termination resistor in the last connected battery.
5. Place the other termination resistor in the other BMS CAN-Bus connection port of MG Master LV.



**Always use machine manufactured full wired RJ45 patch cables.**

Connect the network as following:

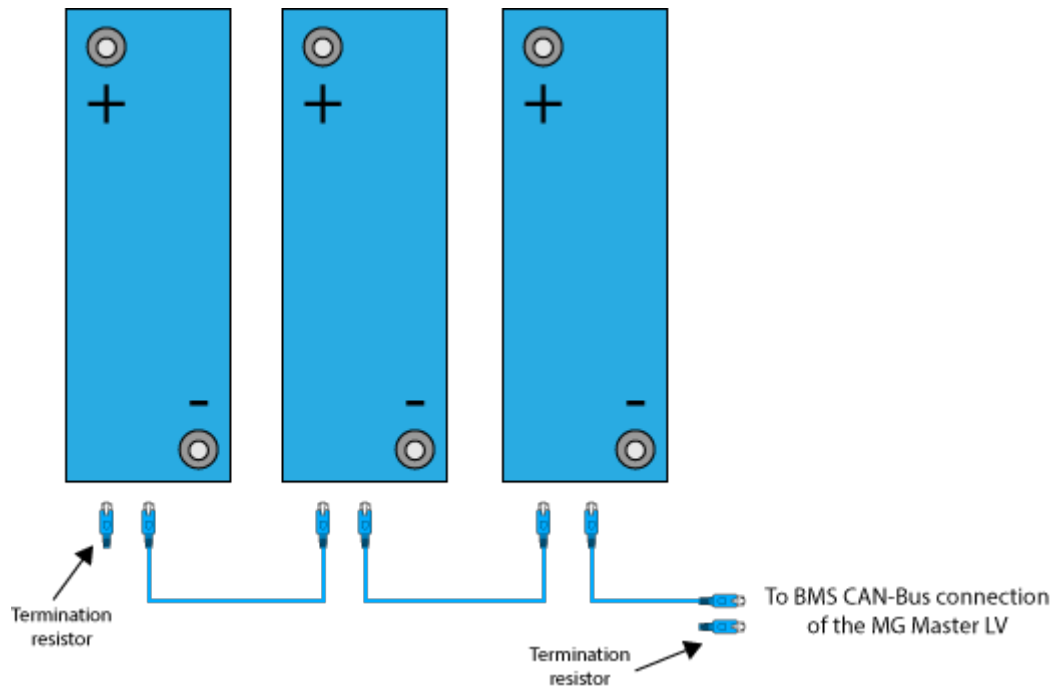

Do not forget the termination resistors at the ends of the CAN-Bus network.

### 3.4.6 Connecting to NMEA2000 network

Use the AUX. CAN-Bus connection of the MG Master LV, for connection to a NMEA2000 network. For details see the MG Master LV communication guide.

### 3.4.7 Connecting the Allow-to-charge and Allow-to-discharge



**The Allow-to-charge and Allow-to-discharge are very important. They control the chargers and loads in the system.**

There are two important functionalities in the Lithium-Ion battery system.

1. All chargers need to stop charging if the batteries are fully charged.
2. All loads need to stop discharging if the batteries are empty.

This kind of functionality of the system can be achieved to use the allow-to-charge and allow-to-discharge of the MG Master LV.

- When the battery is fully charged the allow-to-charge contact is opened and charging has to stop.
- When the battery is fully discharged the allow-to-discharge contact is opened and discharging has to stop.

If charging or discharging is not stopped the safety contactor will be opened to make sure the batteries are not damaged.

See appendix A, connection 'A' and 'B' for the connections of the allow-to-charge and allow-to-discharge contacts.

### 3.4.8 External status output

The external status output can be used for external indication similar as the status LED on the front of the MG Master LV.

Connect a status indicator to connector 'A' pin 5 and 6. This output uses +13,5 VDC.

See appendix A for connections details.

### 3.4.9 External START-button

It is possible to connect an external START-button. This must be connected to pin 4 of connector 'A'. This pin must be switched to GND of the system (pin 6 of connector 'A'). It has the same functionality as the green START-button on the front.



**Use a momentary switch button for this.**

For example a Bulgin MPI002/TE/BL/12 which has a momentary switch and LED function integrated.

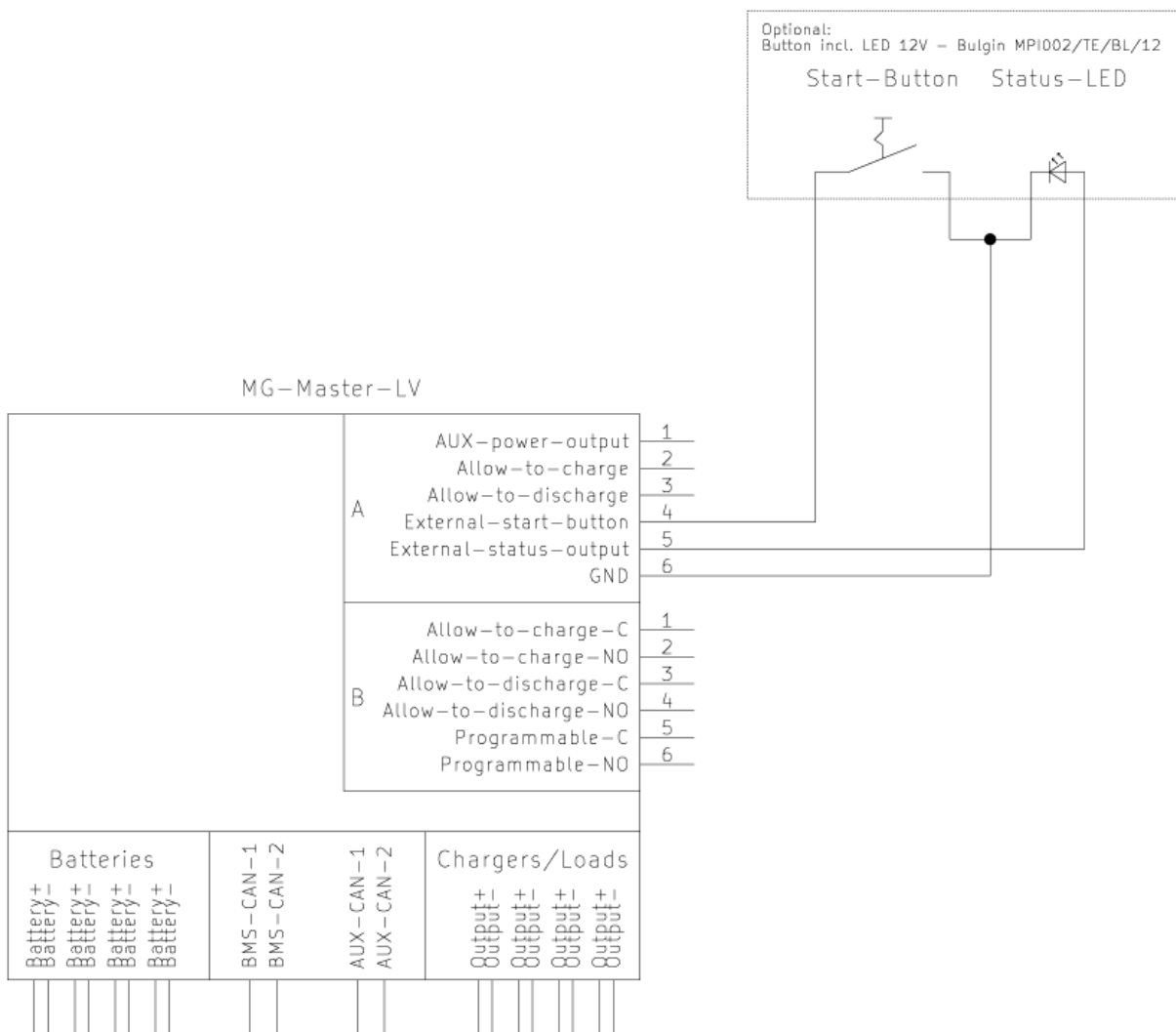

### 3.4.10 Auxiliary power output

The auxiliary power output can be used to power a bilge pump or to power a display. This output will also be powered when the MG Master LV is in fail safe state.

See appendix A, connection 'A' pin 1 and 6 for details.

Example connection of Victron Color Control:

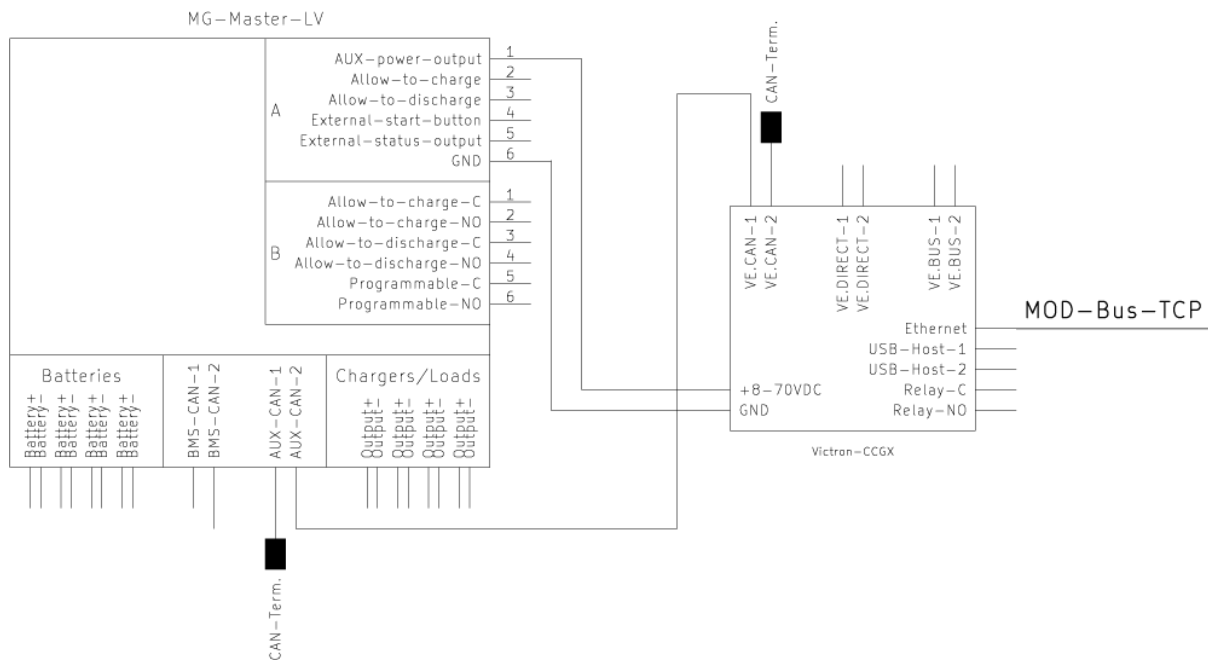

### 3.4.11 Programmable contact

The function of the programmable contact can be selected using the “Diagnostic tool”. This will be added in the future.

## 4 FIRST POWER UP

Other than below procedure, no configuration is needed. The battery configuration is automatically recognized.

### 4.1 Power up procedure

1. Make sure that all energy consumers are switched off before starting up the system, because the MG Master LV will pre-charge the system before closing the safety contactor.
2. Press the START-button (green button) on the front of the MG Master LV to start the system.
3. The system is pre-charging now. The safety contactor is closed as soon as the voltage rises above 80% of the battery voltage.
4. If the status LED is continuously on, the system is running and ready for use.



**The MG Master LV will not start if there is more than 10A drawn by the system during pre-charging. A pre-charge error will be given and the MG Master LV will go to fail-safe.**



**During start-up of the system it is possible that The MG Master LV will going to update the battery firmware if necessary. This is an automatic process and may not be interrupted.**

### 4.2 Power down/reset procedure

*MG Master LV to standby mode:*

1. Press and hold the START-button until the MG Master LV goes into standby mode (status LED off).
2. Now the safety contactor is open and the batteries are disconnected from the system.

*Reset MG Master LV from fail safe state:*

1. Press the START-button for 1 second.
2. The system will now restart.

### 4.3 Automatic power-up

The MG Master LV will automatically power-up from standby if a charge voltage is supplied on the output for more than 10 seconds.



## 5 CONNECTING A VICTRON MULTI OR QUATTRO

### 5.1 Connection of a Victron Energy Multi or Quattro inverter/charger

The Multi and Quattro needs to stop charging when the batteries are fully charged and stop discharging when the batteries are empty. To achieve this the allow-to-charge and allow-to-discharge signal contacts of the MG Master LV are used.

See the switching boundaries document for details about the switching levels for your specific battery.

### 5.2 Connecting the allow-to-charge and allow-to-discharge

#### 5.2.1 Connecting 1 Multi or Quattro

Below an example of how to connect one Multi or Quattro to the MG Master LV.

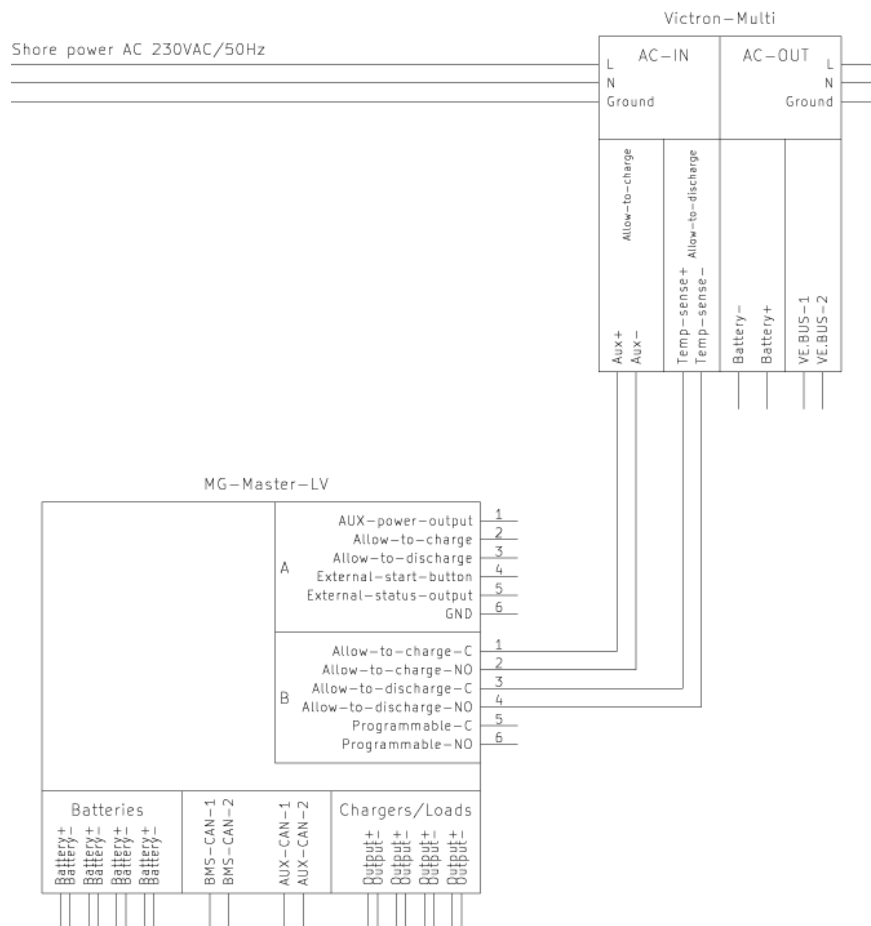

**To use the Victron Quattro/Multi in combination with the MG Master LV, there must be an assistant configured. If the assistant is configured properly, the allow-to-charge and allow-to-discharge contacts are enabled.**

### 5.2.2 Connecting 2 or more Multi's or Quattro's

If 2 or more Multi's or Quattro's are connected to the MG Master LV then an additional relay needs to be installed to extend the Allow-to-charge and Allow-to-discharge contacts.

#### Example: 2 Multi's

The Allow-to-charge and Allow-to-discharge will be extended by a relay with 2 separate contacts to control two Multi's or Quattro's.

Schematic view of the relay that can be used:

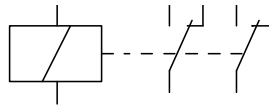

**NOTE: It is also possible to use separate relays to get the required additional contacts.**

Below a schematic view of the setup:

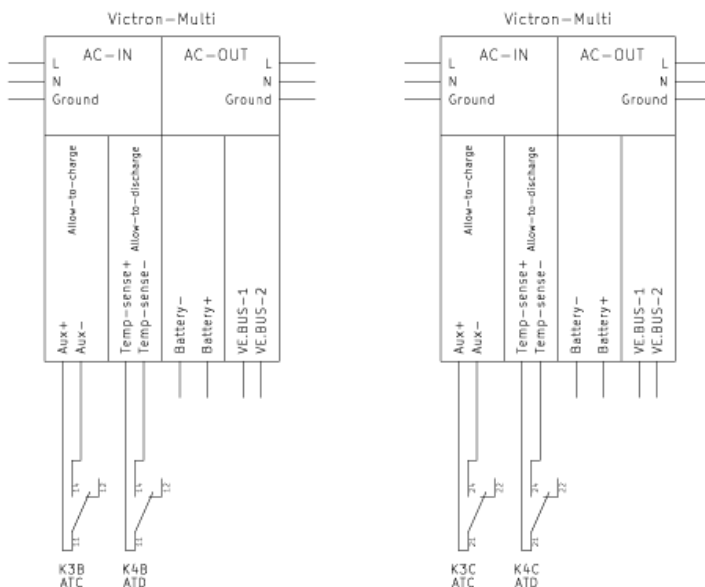
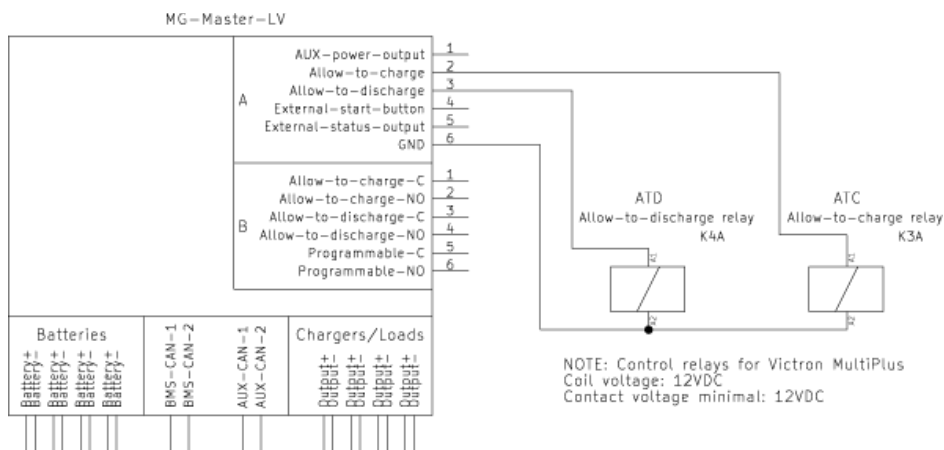

In this schematic relay K3 is the Allow-to-charge and K4 the Allow-to-discharge. The letters 'B' and 'C' are the different contacts within that specific relay.

### 5.3 Configuration of a Multi or Quattro

To configure the Multi for BMS support, VEConfigure3 is necessary. See the Support & downloads section at [www.victronenergy.com](http://www.victronenergy.com) for more information on installing VEConfigure3 and updating the Multi to firmware version xxxx200 or higher.

1. Connect the allow-to-charge signal to the **AUX input** on the Multi or Quattro.
2. Connect the allow-to-discharge signal to **Temp sense input** on the Multi or Quattro. It is not necessary to use a temperature sensor with the Multi or Quattro, since the batteries have their own internal temperature sensors.
3. Add the Lynx Ion BMS assistant in the assistant tab (Virtual switch needs to be off).

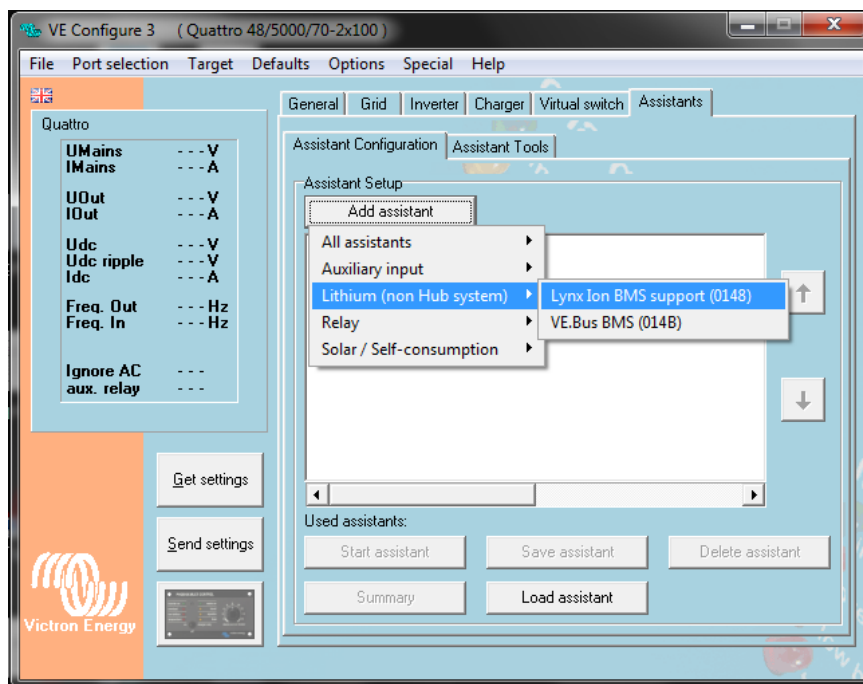

4. Configure the **Lynx-Ion BMS Support assistant** as follows:
  - a. Set battery type selection to: *Change battery type as suggested.*
  - b. Set BMS options to: *The BMS has separate contacts for high-cell/battery full and low-cell conditions.*
  - c. Battery states inputs:
    - i. Set: *The battery is full when Auxiliary 1 is open.*
    - ii. Set: *The battery is empty when Temperature sense input is open.*

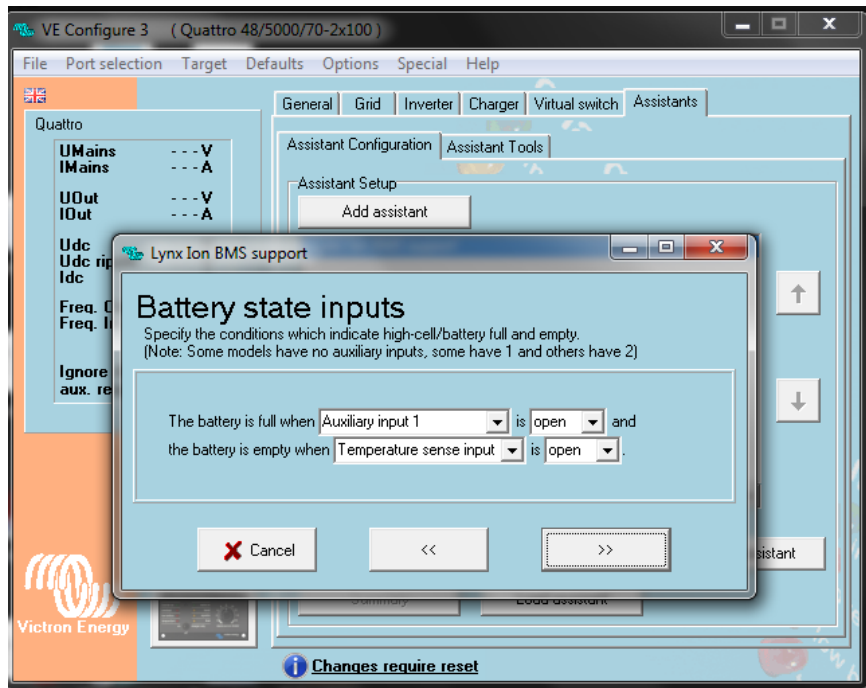

- d. Set action to: *Disable charger when battery is full*. (NOT force to float).

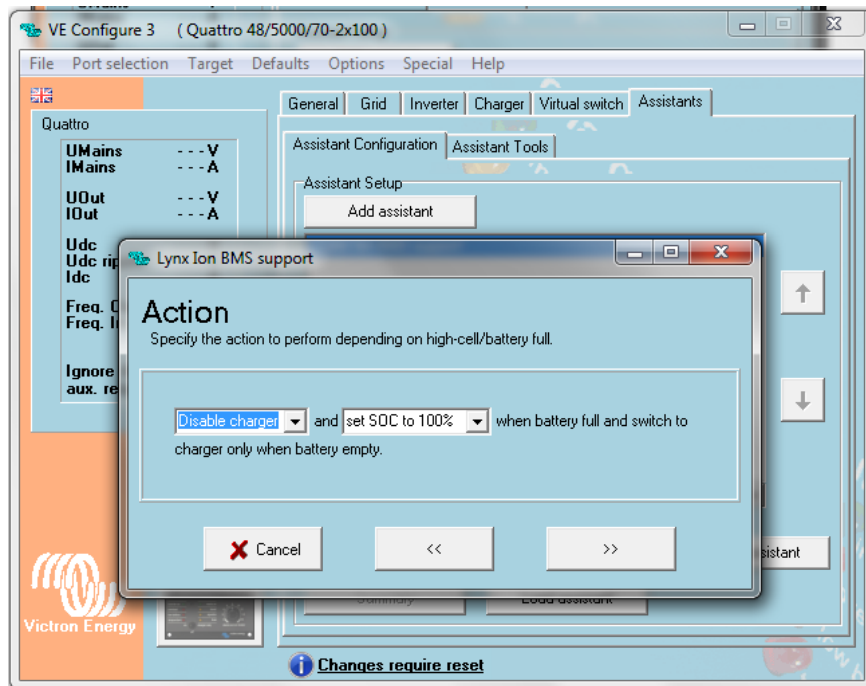

5. Go to the *charger* tab and change the settings to the following:

Set the **absorption voltage** and **float voltage** to the value's specified in the table of chapter 6.

## 6 CHARGER SETTINGS

In the table below are the voltage settings specified for different type of batteries.

Battery type	System Voltage	Absorption voltage	Float voltage
Lithium-Ion HE Battery Module - MGINRHE240XXX	48 V	56,7 V	55,0 V
	24 V	28,4 V	27,5 V
Lithium-Ion LFP Battery Module – MGLFP24XXX	48 V	55,2 V	53,2 V
	24 V	27,6 V	26,6 V

## 7 UPDATING FIRMWARE

The firmware of the MG Master LV can be updated using the “Diagnostic Tool”. Contact your supplier for more information.

### 7.1 Updating procedure

1. Connect the MG USB-CAN Transceiver (article number: MGUSBCAN001) ,Kvaser or PCAN to the BMS CAN-Bus network.
2. Open the “Diagnostic Tool”.
3. Start-up the system by pushing the START button.
4. The MG Master will be automatically updated if a newer firmware version is available.
5. System will shut down and perform the update.
6. When the update was successful, the system will start-up automatically.
7. During start-up the firmware of the batteries is checked and will be updated if necessary.

### 7.2 Connecting a CAN to USB Interface

To use the “Diagnostic Tool” a CAN to USB interface needs to be connected. This can be a Kvaser, PCAN or MG USB-CAN Transceiver.

Pinning is as following:

RJ45 pin	Description	Ethernet cable wire color
1		
2		
3	GND	White/Green
4		
5		
6	V+ (13,5V)	Green
7	CAN-H	White/Brown
8	CAN-L	Brown

## 8 COMMISSIONING

Below describes the procedure for commissioning the Lithium-Ion battery system.

### 8.1 Procedure

Use the following procedure to verify the systems functionality:

#### Check the firmware version of the MG Master LV:

- The MG Master LV firmware version is updated to the latest release.

#### Check that there are no loads or chargers connected directly to the batteries:

- The power cables from the battery goes directly to the MG Master LV, and there are no other power cables present.

#### Check for each and every charger in the system that it is controlled by the allow-to-charge:

- Make sure the battery is not fully charged. The allow-to-charge indicator on the Victron Color Control GX shows **Yes** or the “Diagnostic Tool” shows **charging allowed**.
- Make sure the charger is charging by reading the battery current from the Victron Color Control GX. This has to be a positive number (for example 10.5A).
- Disconnect one wire from the allow-to-charge (connector ‘A’, pin 2 or connector ‘B’, pin 1).
- Check that all chargers stopped charging by reading the battery current from the Victron Color Control GX. This has to be 0A or a negative number (discharging).

#### Check for each and every loads in the system that it is controlled by the allow-to discharge:

- Make sure the battery is not completely empty. The allow-to-discharge indicator on the Victron Color Control GX shows **Yes** or the “Diagnostic Tool” shows **discharging allowed**.
- Make sure the loads are consuming some energy by reading the battery current from the Victron Color Control GX. This has to be a negative number (for example -10.5A).
- Disconnect one wire from the allow-to-discharge (connector ‘A’, pin 3 or connector ‘B’, pin 3).
- Check that all loads stopped consuming energy by reading the battery current from the Victron Color Control GX. This has to be 0A or a positive number (charging).

#### Check system ready for use:

- Make sure that the batteries are fully charged the first time by checking if the battery State-Of-Charge is around the 100% by reading this from the Victron Color Control GX (the first time it will indicate a ‘-’ which means that the SOC is not valid).

## 9 LED INDICATIONS

Firmware version 1.XX and higher.

Status LED state	Description
Off	System is in standby mode. Press START button to start up the system
On	Running
Blinking	Updating firmware of connected batteries
Flashing/beeping 2 times	Battery communication error (check BMS CAN-Bus cables)
Flashing/beeping 3 times	Under or overvoltage detected (check charger or load settings)
Flashing/beeping 4 times	Under or over temperature detected (check battery temperatures)
Flashing/beeping 5 times	Pre-charge time out occurred (check if pre-charge current is below 10A)
Flashing/beeping 6 times	Pre-charge fuse broken (check the pre-charge fuse)
Flashing/beeping 7 times	Battery configuration failure (check BMS CAN-Bus cables)
Flashing/beeping 8 times	N.A.
Flashing/beeping 9 times	Battery firmware updating failure (contact manufacturer)
Flashing/beeping 10 times	Main safety contactor failure (contact manufacturer)
Flashing/beeping 11 times	Internal measurement failure (contact manufacturer)
Flashing/beeping 12 times	System instability problem detected (contact manufacturer)
Flashing/beeping 13 times	No appropriate firmware found for connected battery (contact manufacturer)



## **10 MAINTANANCE**

This product does not require specific maintenance. It will suffice to check all connections once a year. Avoid moisture and oil/soot/vapors, and keep the device clean.

## 11 TECHNICAL SPECIFICATIONS

### 11.1 MG Master LV 48V 150A/400A/600A/1000A

Technical specifications	150A	400A	600A	1000
Maximum number of batteries in series	2 (= 48 V)			
Maximum number of batteries in parallel	48			
Supply voltage range	18 ... 58 VDC			
Standby mode	73 mW @ 26,2 V and 138 mW @ 52,4 V			
Active mode	8,7 W			
Main safety contactor current continuous	150 A	400 A	600 A	1000 A
Communication	CAN-Bus (NMEA2000, SMA, custom on request)			
<b>IO</b>				
Aux. output	13,5 V / 1 A, short circuit protection, overcurrent protection			
Allow-to-charge (switched voltage)	13,5 V / 1 A, short circuit protection, overcurrent protection			
Allow-to-discharge (switched voltage)	13,5 V / 1 A, short circuit protection, overcurrent protection			
Allow-to-charge (relay output)	0,8 A @ 60 VDC, potential free			
Allow-to-discharge (relay output)	0,8 A @ 60 VDC, potential free			
Programmable contact (relay output)	0,8 A @ 60 VDC, potential free			
External status signal	13,5 V / 140 mA			
<b>Enclosure</b>				
Material	ABS			
Dimensions	185 x 165 x 85 mm			
Weight	4,0 kg	5,0 kg	5,0 kg	5,7 kg
<b>Environmental</b>				
Operating temperature range	-20 °C to 50°C			
Humidity	Max. 95% (non-condensing)			
Protection class	IP22			
<b>Standards</b>				
EMC: Emission	EN-IEC 61000-6-3:2007/A1:2011/C11:2012			
EMC: Immunity	EN-IEC 61000-6-1:2007			
Low voltage directive	EN 60335-1:2012/AC:2014			
RoHs	EN 50581:2012			

## APPENDIX A: Connection overview of the MG Master LV

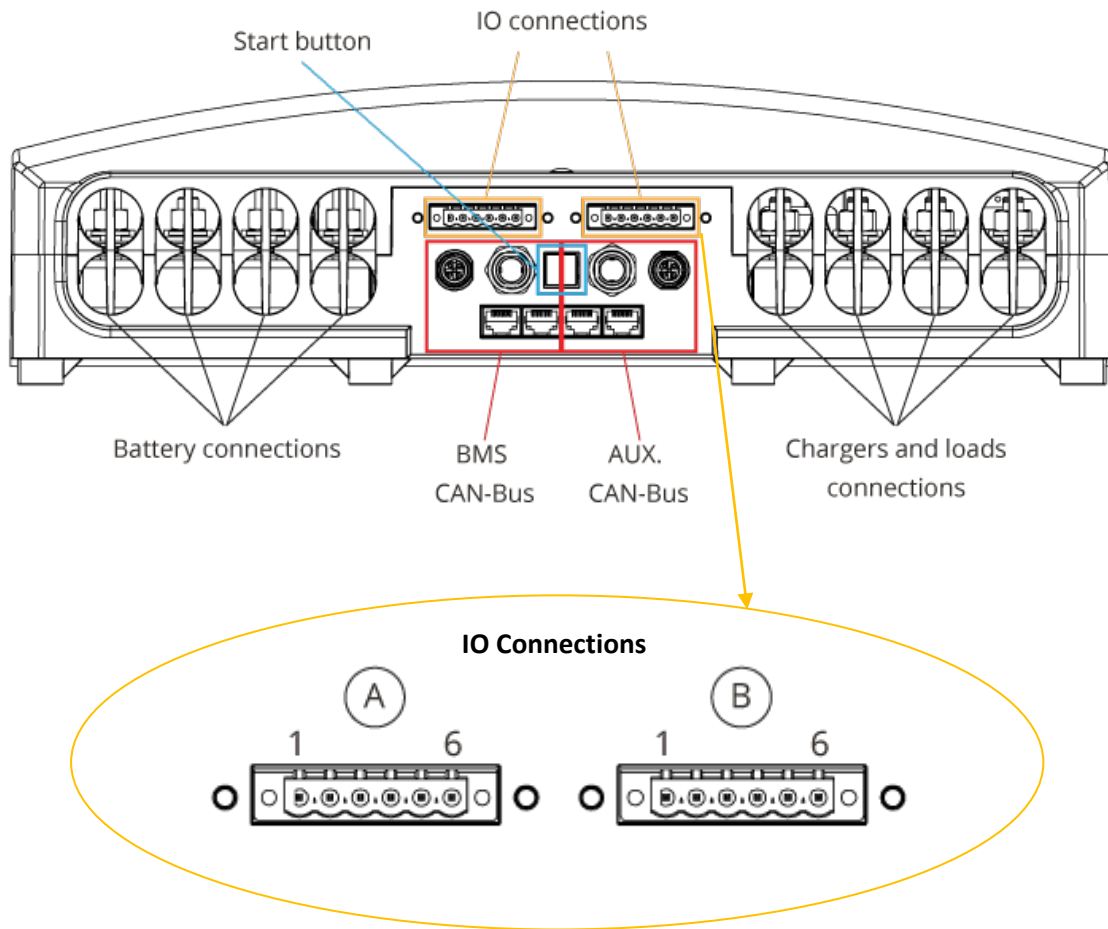

Connector pins and specifications					
Conn.	Pin	I/O	Voltage	Current	Purpose
A	1	Out	13,5 V	1 A	Aux. power output
	2	Out	13,5 V	1 A	Allow-to-Charge
	3	Out	13,5 V	1 A	Allow-to-Discharge
	4	In			External start button
	5	Out	13,5 V	140 mA	External status output
	6	-			GND
B	1	Out	Max. 60 VDC	0,8 A @ 60 VDC	Allow-to-charge
	2				
	3	Out	Max. 60 VDC	0,8 A @ 60 VDC	Allow-to-discharge
	4				
	5	Out	Max. 60 VDC	0,8 A @ 60 VDC	Programmable output
6					

## APPENDIX B: Inside the MG Master LV

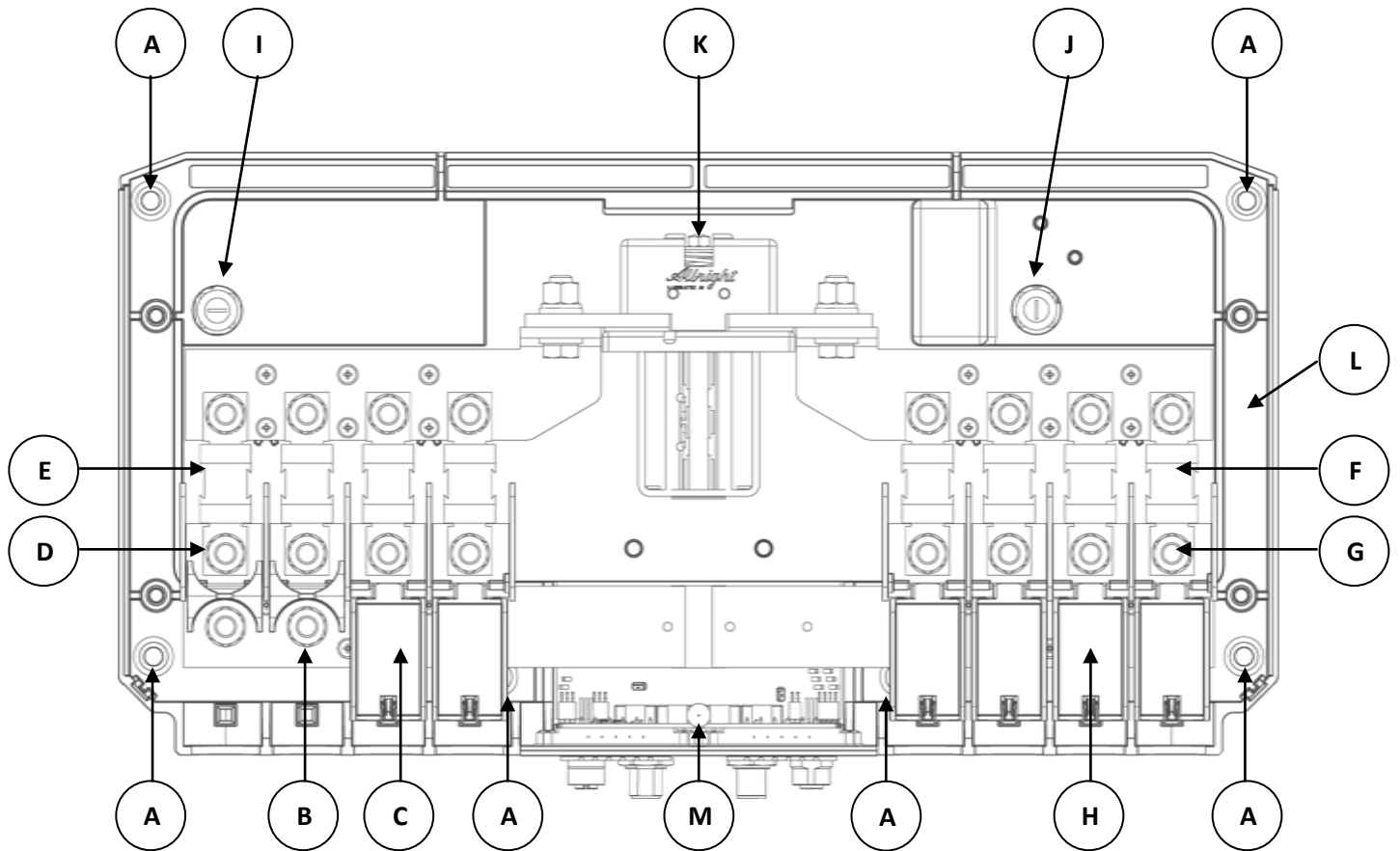

Part	Description
A	Mounting holes
B	'-' minus battery connections (M8 bolt connections)
C	Plastic insulation part
D	'+' positive battery connections (M8 bolt connections)
E	Battery side fuses
F	Loads/Chargers side fuses
G	'+' positive Loads/Chargers connections (M8 bolt connections)
H	'-' minus Loads/Chargers connections (below plastic insulator) (M8 bolt connections)
I	Fuse of main control unit
J	Pre-charge fuse
K	Safety contactor (can be 150A/400A/600A/1000A)
L	Bluetooth Smart (NFC antenna )
M	Status LED

## APPENDIX C: Dimensions

Dimensions in mm.

